



Standard Guide for Laboratory Subsampling of Media Related to Waste Management Activities¹

This standard is issued under the fixed designation D 6323; the number immediately following the designation indicates the year of original adoption or, in the case of revision, the year of last revision. A number in parentheses indicates the year of last reapproval. A superscript epsilon (ϵ) indicates an editorial change since the last revision or reapproval.

1. Scope

1.1 This guide covers common techniques for obtaining representative subsamples from a sample received at a laboratory for analysis. These samples may include solids, sludges, liquids, or multilayered liquids (with or without solids).

1.2 The procedures and techniques discussed in this guide depend upon the sample matrix, the type of sample preparation and analysis performed, the characteristic(s) of interest, and the project specific instructions or data quality objectives.

1.3 This guide includes several sample homogenization techniques, including mixing and grinding, as well as information on how to obtain a specimen or split laboratory samples.

1.4 This guide does not apply to air or gas sampling.

1.5 The values stated in SI units are to be regarded as the standard.

1.6 *This standard does not purport to address all of the safety concerns, if any, associated with its use. It is the responsibility of the user of this standard to establish appropriate safety and health practices and determine the applicability of regulatory limitations prior to use.*

2. Referenced Documents

2.1 ASTM Standards:

C 702 Practice for Reducing Samples of Aggregate to Testing Size²

C 859 Terminology Relating to Nuclear Materials³

D 346 Practice for the Collection and Preparation of Coke Samples for Laboratory Analysis⁴

D 2234 Test Methods for Collection of a Gross Sample of Coal⁵

D 4547 Guide for Sampling Waste and Soils for Volatile Organic Compounds⁵

D 4823 Guide for Core Sampling Submerged Unconsolidated Sediments⁵

D 5743 Practice for Sampling Single or Multilayered Liq-

uids, With or Without Solids, in Drums or Similar Containers⁶

D 5792 Practice for Generation of Environmental Data Related to Waste Management Activities: Development of Data Quality Objectives⁶

D 5956 Guide for Sampling Strategies for Heterogeneous Wastes⁶

D 6051 Guide for Composite Sampling and Field Subsampling for Environmental Waste Management Activities⁶

3. Terminology

3.1 *contaminant unit, n*—the largest particle size that contains the contaminant of interest

3.1.1 *Discussion*—The contaminant of concern, as defined by the project objectives, may be associated with all the particle sizes or associated with only a certain particle size or sizes. At the time of waste generation, discharge or spill, the particle size of this contaminant of concern may be on the atomic or molecular scale, such as solvent spill into sand, or a macro scale, such as lead acid batteries at a dump site. The contaminant unit may also be in-between these scales, such as lead particles encapsulated in coal. In practice, the contaminant unit may change if the contaminant unit becomes absorbed or adsorbed to particles larger than the contaminant unit. It is the size of the contaminant unit at the time of subsampling, not at the time of generation, that is referred to as the contaminant unit.

3.2 *maximum allowable particle size, n*—the largest lineal dimension of a sample's individual particles accepted for a given sample mass.

3.2.1 *Discussion*—The maximum allowable particle size is sometimes referred to as the allowable particle size. A simple method of measurement is a sieve.

3.3 *multilayered sample, n*—a sample consisting of two or more clearly differentiated components.

3.3.1 *Discussion*—Multilayered samples are those with two or more distinct visual layers of material. These layers may be the result of differences in density, such as liquid/liquid layers (for example, chlorinated solvents and water, water and oil), liquid/solid layers (for example, sludge), solid/solid layers (for example, small rocks and large rocks), or combinations of these layers (for example water, oil, and soil). These layers

¹ This guide is under the jurisdiction of ASTM Committee D34 on Waste Management and is the direct responsibility of Subcommittee D34.01.01 on Planning for Sampling.

Current edition approved Sept. 10, 1998. Published December 1998.

² *Annual Book of ASTM Standards*, Vol 04.02.

³ *Annual Book of ASTM Standards*, Vol 12.01.

⁴ *Annual Book of ASTM Standards*, Vol 05.05.

⁵ *Annual Book of ASTM Standards*, Vol 11.02.

⁶ *Annual Book of ASTM Standards*, Vol 11.04.



may also be the result of depositional layering, such as green clay and silty sand from a coring sample.

3.4 *particle size, n*—the controlling lineal dimension of individual particles (see Terminology C 859).

3.5 *representative subsample, n*—a subsample collected in such a manner that it reflects one or more characteristics of interest (as defined by the project objectives) of the laboratory sample from which it was collected.

3.5.1 *Discussion*—A representative subsample can apply to a single sample, or a composite sample.

3.6 *sample, n*—a portion of material taken from a larger quantity for the purpose of estimating properties or composition of the larger quantity, (see Guide D 6051).

3.7 *sludge, n*—Any mixture of solids that settles out of solution. Sludges contain liquids that are not apparent as free liquids, (see Practice D 5743).

3.8 *subsample, n*—a portion of a sample taken for the purpose of estimating properties or composition of the whole sample, (see Guide D 6051).

3.8.1 *Discussion*—A subsample is also commonly referred to by such terms as specimen, aliquot, subsample, or analytical subsample. To avoid confusion, the term specimen is used to refer to the final portion of the sample used during analysis. The material received at the laboratory will be referred to as the laboratory sample. All portions subsampled in-between receipt at the laboratory and the specimen are referred to as subsamples. The subsample may be the specimen.

4. Significance and Use

4.1 This guide discusses options for taking a subsample from a sample submitted to a laboratory. If followed, it will minimize the bias and variance of the characteristic of interest of the laboratory sample prior to analysis.

4.2 The guide will describe appropriate instructions to be submitted to the laboratory with the field sample.

4.3 This guide is intended for use in the laboratory to take a representative subsample or specimen of the whole field sample for direct analysis or sample preparation for analysis. It is intended for field personnel, data users, laboratory sample reception personnel, analysts, and managers.

4.4 To obtain a representative subsample, layer analysis, grinding, mixing, and changing the physical state such as digesting, drying, melting or freezing may be required. This guide considers cone and quartering, riffle splitting, and particle size reduction.

5. General Considerations

5.1 Successful implementation of this standard depends on effective communication between the data user and the laboratory staff. The selection of optimal subsampling procedures, techniques, and strategy by the laboratory depends on the intended use of the data. The data user should submit appropriate instructions with all samples and, when necessary, the laboratory staff should contact the data user for confirmation or further clarification of these instructions.

5.1.1 The appropriate instructions must be reviewed by both the laboratory receiving personnel and the analyst(s) or supervisor. If there are no instructions, the appropriate laboratory personnel should contact the data user. Options should be

discussed and clarified prior to initiating any subsampling procedure. These instructions may include such options as those found in Table 1. The limitations and advantages of these methods are also found in this table. The data user should be informed about the limitations and advantages of all subsampling procedures prior to deciding which one to use.

5.1.2 If the data user still provides no instructions upon being contacted, laboratory personnel should explain to the data user that the laboratory's standard operating procedures, which reflect the concerns and issues discussed in this standard, will be used. The sample should be treated as if the scale of the contamination is on the micro level, and no artifacts can be removed. Since sample matrices and types and mechanisms of contamination are infinitely variable and require judgments to be made, it is advisable that experienced analysts decide which subsampling techniques be employed. These procedures must be discussed and clarified with the data user prior to initiating any subsampling procedure.

5.2 If the sample integrity or composition is not as anticipated, the data user must be contacted to confirm or clarify the instructions. An example of when this would be necessary would be a case where a coring sleeve was received at the laboratory. On opening the container, the analyst notices clay in one end of the sleeve, and sand at the other end. Before the analyst can proceed, the appropriate instructions from the data user must be obtained.

5.2.1 Field samples should be collected in appropriate containers for the analyses requested. If the submitted sample is improperly collected, the data user should be contacted by laboratory personnel. If the data user authorizes the laboratory to continue with the analysis, a note should be made in the receipt documentation, and also in the case narrative in the final report.

5.3 Documentation during the subsampling process is critical. Since subsampling techniques may bias the results, the subsampling method used must be noted in the analytical logbook.

5.3.1 Anytime the analytical result will be biased, it must be documented, and the data user should be notified prior to beginning any subsampling technique. For example, if headspace exists in a container arriving at the laboratory, some volatile components will have partitioned into that headspace. However, if the data user decides to proceed with the analysis, the analytical logbook and the case narrative on the final report should indicate this condition.

5.4 Particle size is the physical dimension of an object's pieces or parts. The maximum particle size contained within a laboratory sample is the largest of these pieces. The contaminant of concern, as defined by the project objectives, may be associated with all particle sizes or associated with only a certain particle size or sizes. The largest of these particle sizes, that contain the contaminant of interest, would be the contaminant unit. The contaminant unit, at the time of waste generation, discharge or spill, may be on the atomic or molecular scale, such as a solvent spill into sand, or a macro scale, such as lead acid batteries at a dump site. The contaminant unit may also be in-between these scales, such as lead particles encapsulated in coal. In practice, the contaminant unit may change if



TABLE 1 Limitations and Advantages of Sample Preparation Options

Instruction	Limitations	Advantages
Remove artifacts, such as rocks and twigs, from the sample prior to subsampling	(1) May bias analytical results by altering contaminant concentration, (2) May bias sample if results are not properly weight averaged.	(1) May be easier to subsample, (2) May be easier to analyze, (3) Appropriate if the target population is material minus artifacts.
Digest or extract the contaminant from the outside of the large particles	May bias sample if contaminant is within the large particles. ^A	(1) May be easier to analyze, (2) May prevent need for weight average calculation.
Digest or extract particle sizes separately	(1) Separation of particle sizes may be difficult, ^A (2) May bias sample if results are not properly weight averaged, (3) Higher cost.	(1) Allows some particle size consistency during analysis, (2) May be easier to subsample within portions after separation.
Form an emulsion layer so that the material may be treated as homogeneous liquid	May bias the sample if a complete emulsion is not achieved. ^A	(1) May be easier to subsample as a homogeneous liquid,
Separate liquid layers	(1) Separation of layers may be difficult, especially at the interface, (2) May bias sample if results are not properly weight averaged.	(1) May be easier to analyze, (2) May be easier to subsample within portions after separation, (3) Allows different preparation methods within each layer.
Dry sample	May alter chemistry or change stability of some compounds. ^A	(1) Allows for consistency of subsampling for liquid/solid mixtures, (2) Analytes reported unbiased by moisture content.
Change the physical state, such as freeze the material so that it may be treated as a solid, or melt the material so that it may be treated as a liquid	May be difficult to achieve complete freezing or melting and maintain it long enough to get a subsample. ^A	Allows for consistency of subsampling.
Analyze only one layer of multilayered samples, such as analyze only the oil portion of an oil/water mixture for PCBs	May bias the sample if there is cross-contamination between layers	(1) Possible cost savings to customer, (2) May be easier to subsample from a single layer, (3) May be easier to analyze.
Composite portions of the sample for volatile analysis directly in a purge unit vs. individual analysis of these portions	(1) May overload gas chromatography columns if sample has high amounts of solvents in each portion, (2) Separation of portions may be difficult.	(1) May prevent losses of volatile because the sample is handled only once, (2) Possible cost savings to customer, (3) May prevent need for weight average calculation.
Reduce particle size	(1) Increasing surface area may effect data in some procedure with particle digestion or extraction, such as TCLP, ^A (2) May be difficult, depending on matrix.	Allows for consistency of subsampling.
Use standard methods for solids (for example, cone and quarter, grind, riffle, sieve)	Dependent on method. ^A See 7.1.5 for more information.	Dependent on method. See 7.1.5 for more information.

^AMay be unsuitable for samples to be analyzed for volatile constituents.

the contaminant becomes absorbed or adsorbed to particles larger than the contaminant unit.

5.4.1 Knowledge of the contaminant unit may be used to determine the preliminary steps to subsampling. For example, if the contaminant unit is on a molecular scale and was adsorbed to soil particles and rocks, removal of large rocks with their relatively small surface area may not affect the data as long as the results are weight averaged. If one is unsure of the mechanism of contamination, that determines how the contamination is dispersed within the sample matrix, one may not be able to discard any particles during subsampling.

5.5 Sampling theory requires that subsample *mass* should increase as the size of the largest particle in the sample increases. If the subsample mass recommended by sampling theory is larger than that normally used in the sample preparation method, the subsample mass may be increased and the extraction/digestion procedure scaled accordingly. The standard volume of digestate/extract is then submitted for analysis. However, if the subsample mass is too large to be accommodated by the sample preparation procedure, multiple subsamples (of equal mass) can be extracted/digested, and the extracts/digests combined and mixed prior to removal of the standard volume specimen needed for analysis. Another alter-

native is to reduce the particle size of the entire sample or subsample as specified by sampling theory. If the particle size is reduced enough, a subsample of the mass recommended by sampling theory and the extraction/digestion method can be obtained.

5.6 All subsampling should be performed in an area which is free from contamination, easily decontaminated, and vented to control dust and remove fumes.

5.7 Prior to subsampling liquids, the analyst must consider the property or characteristic requested, and the container size received. If the analyte has the ability to adsorb onto the container, the field sample should arrive at the laboratory in an appropriately sized bottle, such that the whole sample will be used. The sides of the container should then be rinsed properly to assure that all the contaminants are transferred into the analytical vessel.

5.8 Subsampling techniques are different when analyzing for volatile compounds than non-volatile compounds. The differences are discussed for each sample matrix.

6. Matrix Specific Subsampling

6.1 Solids:

6.1.1 Table 2 gives the relationship between the maximum

TABLE 2 Recommended Minimum Subsample Mass for Particulate Materials to Achieve a Fundamental Error of 15 %

Recommended Minimum Subsample Mass, g	Maximum Allowable Particle Size ^A , cm	Size Class ^B	U.S. Standard Sieve Mesh Size
0.1	0.05	Clay to coarse sand	35
1	0.1	Coarse to very coarse sand	18
2	0.13	Very coarse sand	13
5	0.17	Very coarse sand	12
10	0.21	Granule gravel	10
30	0.31	Granule gravel	7
50	0.37	Granule gravel	6
100	0.46	Pebble gravel	5

^AThe maximum allowable particle size allowed can be approximated for other sample masses by using the equation, allowable particle size (cm) = the cube root of 0.001 × sample mass in grams

^BWentworth Size Class (See (3) and (4)) These soil descriptions are added for those readers who equate particle size with the Wentworth descriptions and are not meant to indicate that the application of this table is limited to soil particles. The table can also be used for non-soil particles such as waste.

particle size and sample mass to achieve a fundamental error of 15 %. For information about fundamental error, see Ref (1)⁷. If the maximum allowable particle size is greater than that listed in the table, then sampling theory would suggest particle size reduction, such as grinding, or use of a larger sample mass. For example, if granule gravel has an allowable particle size of 0.21 cm, according to this table, a subsample mass of 10 g is needed. Many digestions/extractions commonly use 1 g. The 10 g subsample would be ground to a size of 0.1 cm, and the specimen would be taken from the ground material. Approximations were employed to construct this table. The actual fundamental error could be much larger. More information on calculating the maximum allowable particle size for various fundamental errors, and particles shapes is included in Annex A1.

6.1.1.1 Particle size reduction can be avoided by modifying the sample digestion/extraction methods to use large specimen masses. Following digestion/extraction of the large specimen, the homogeneous digestate/extract is analyzed. For example, if the contaminant of concern was a chromium solution spilled into a mixture of gravel and soil, knowing that the chromium coats the medium allows a choice of sample preparation. The analyst may totally dissolve the specimen. He/she may digest the chromium from the outside of the particles, analyzing the digestate. Or, he/she may extract the material, and analyze the extractant. If the analyst had no information about the mechanism of contamination, he/she would have to assume that the contamination is throughout all particles of the laboratory sample.

6.1.1.2 If information is available regarding the type and mechanism of contamination, then it may be possible to avoid particle size reduction and the use of large specimen masses. For example, if contamination occurred on a molecular level (for example, a solvent is discharged to soil), an argument can be made to preclude large particles (for example, rocks), since insignificant amounts of contamination will be adsorbed to the

small surface of the large particles. If the large particles are excluded, the appropriate mass can be based on the smaller particle sizes, which have a much larger surface area. If the decision is made to remove the large particles, the mass of both the large and small particles would be used to calculate the final concentration of the contaminant of interest.

6.1.2 If larger sample masses are required, two ASTM Standards may be helpful. Test Method D 2234 discusses test methods and procedures for the collection of a sample under various conditions of sampling. It describes general and special purpose sampling procedures for coal by size, condition, and characteristics. The document also includes in the annex, a test method for determining the variance of components of a coal and a test method for estimating the overall variance for increments of one fixed weight of a given coal.

6.1.2.1 A second method which is often referenced by other ASTM standards dealing with coals is Practice D 346. The practice is designed to provide a representative sample of the coke from which it is collected. It considers the variability of coke and the wide variety of sampling equipment.

6.1.3 If the desired subsample mass is equal to or less than the maximum allowable particle size, subsampling can proceed without any need for particle size reduction. If the particle size is greater than the allowable particle size in Table 2, then the sample matrix, the type and mechanism of contamination, the scale of the contaminant unit, as well as particle size reduction should be considered. These allowable particle sizes are based on the assumption that the contaminant exists as a particle or is adsorbed to particles. In those cases where the contaminant unit is on the atomic or molecular scale or is a particle much smaller than the allowable particle size of the sample, then alternative approaches can be employed with acceptable bias.

6.1.4 *Solid Samples for Volatile Analysis:*

6.1.4.1 Due to the volatility of this class of compounds, laboratory subsampling procedures addressing the sample's allowable particle size could result in large losses of the parameter of interest, rendering the results unrepresentative. The possible exception is when cryogenic freezing conditions are maintained throughout the handling process.

NOTE 1—If cryogenic techniques (working with frozen samples) or other special techniques are used, the procedure should be validated on laboratory control samples (LCS) which have been spiked with known concentrates of the parameter of interest. The nature of the test matrix for the LCS and the spiking solution should be chosen to allow uniform distribution of the spike in the matrix prior to subsampling. Regardless of the particle size reduction techniques chosen, it is advisable to carry an LCS through each preparation batch as a quality control sample. A subsample of the field sample without particle size reduction through the validation procedure will demonstrate the amount of volatile loss (from the LCS results) and increased volatiles recovery (from a comparison of the unreduced field sample with the size reduced sample) using particle size reduction.)

6.1.4.2 When analyzing samples for low levels of volatile constituents (0.5 to 200 µg/kg range), discrete samples should be placed into a container that, once sealed, is analyzed without opening (see Guide D 4547). For this reason, and because sample mass is often limited by the analysis system, low level samples typically are not amenable to either particle size reduction procedures or the analysis of larger sample mass.

⁷ The boldface numbers given in parentheses refer to a list of references at the end of the text.

When contaminant levels exceed 200 µg/kg, discrete samples can be transferred to vessels containing an appropriate solvent, such as methanol. Because the solvent retains the volatiles in solution, and only a small portion of the solvent is removed for analysis, particle and contaminant unit size with respect to subsample mass requirements can be considered.

NOTE 2—Current analytical guidance recommends solvent extraction only for volatile organic concentrations at greater than 200 µg/kg. However, solvent extraction may be used for solvents of lower concentration levels if the solvent/solid ratio is reduced, or by using an analysis system with lower detection limits.

6.1.4.3 The following subsections discuss different subsampling procedures that can be used as particle size and contaminant unit vary in relationship to the allowable particle sizes listed in 6.1.1.

6.1.5 *Laboratory Sample Particle Size and Contaminant Unit Less Than the Allowable Particle Size*—Prepare sample vessel with the appropriate solvent and solvent volume as specified in the method. Add the appropriate mass of sample to the prepared vessel with a pre-cleaned coring tool (see Guide D 4547) or spatula as quickly as possible. The coring tool must be large enough to accommodate the largest sample matrix particle. After volatile extraction, remove the appropriate volume of the solvent for analysis from the liquid portion of the specimen.

6.1.6 *Laboratory Sample Particle Size Greater Than the Allowable Particle Size and the Contaminant Unit Less Than the Allowable Particle Size*—Particle size reduction cannot generally be used, since it may result in a loss of volatile contaminants. There are cases where the chemistry of the contaminant and the support will not allow the volatile to be lost. For these types of contaminants, see the methods in 6.1.5. Alternate approaches to subsampling may be viable if knowledge exists regarding the sample matrix, type and mechanism of contamination, and the contaminant unit.

6.1.6.1 If the contaminant unit is on a molecular scale, then the distribution of the contaminant will be a function of the absorptive properties, and the larger surface area of the smaller particles results in more contaminants being adsorbed to the smaller particles. If the data user is willing to accept a biased-high concentration for the contaminant of interest, a subsample of only the smaller particles may be made.

6.1.6.2 Another method is to use a solvent appropriate for analysis, such as methanol, to extract the material. Use a 4 g specimen of the original laboratory sample in 10 mL of solvent. Increase the volumes proportionally to accommodate the specified sample mass. An appropriate portion of the solvent is analyzed once the contaminant is dissolved in the solvent.

6.1.7 *Laboratory Sample Particle Size and Contaminant Unit Larger than the Allowable Particle Size*—When sample masses become prohibitive with regard to logistical constraints, sample extracts can be composited. An example of this is the case where soil of particle size 0.46 cm is contaminated with volatile organic compounds. The suggested subsample mass in this case from Table 2 is 100 g, therefore requiring a vessel with 250 mL of solvent. As an alternate to a single large sample, five 20 g subsamples could be extracted. Microliter amounts of each of the five resulting extracts could

be composited into the same purge chamber. Once the contaminants are dissolved in the solvent, the concern of contaminant heterogeneity is decreased and the use of small subsamples of the extracts can be justified.

6.1.8 *Solid Sample for Non-Volatile Analysis*—The method of subsampling is dependent on the size of the allowable particle size and the size of the contaminant unit. The following subsections discuss different subsampling procedures that can be used as laboratory sample particle size and contaminant unit vary in relationship to the allowable particle sizes listed in Table 2. If the laboratory sample requires mixing prior to subsampling, the methods in section 6.1.6 should be used.

6.1.9 *Laboratory Sample Particle Size and Contaminant Unit Less Than the Allowable Particle Size*:

6.1.9.1 *Transversal Subsampling (Rectangular Scoop)* (see Fig. 1)—One method of subsampling the materials is to use transversal subsampling (see Guide D 6051). The entire laboratory sample is emptied onto a non-contaminating smooth surface. The sample is shaped into an elongated pile with a flattened top surface (1). Complete top-to-bottom transversal cuts are made across the pile and the extracted material is transferred into a tared container. The transversal cuts are repeated until; the appropriate mass is obtained. Cuts are made with a rectangular scoop. The width of the transversal section should be wide enough to accommodate the largest particle size, but narrow enough to require multiple transversal sections be used to obtain the appropriate mass. Two thin sheets of Teflon, metal, or polyethylene may be used to facilitate the removal of material within the transversal cut. After the removal of a few transversal sections, the pile may be reshaped to facilitate further cuts. The entire unused portion of the laboratory sample should be returned to the original sample container.

6.1.9.2 *Cone and Quartering* (see Fig. 2)—Another method of subsampling materials involves cone and quartering (2). This method may introduce large biases from the grouping and segregation error. It is discussed here due to its widespread use, but the user should take note of its limitations (see Table

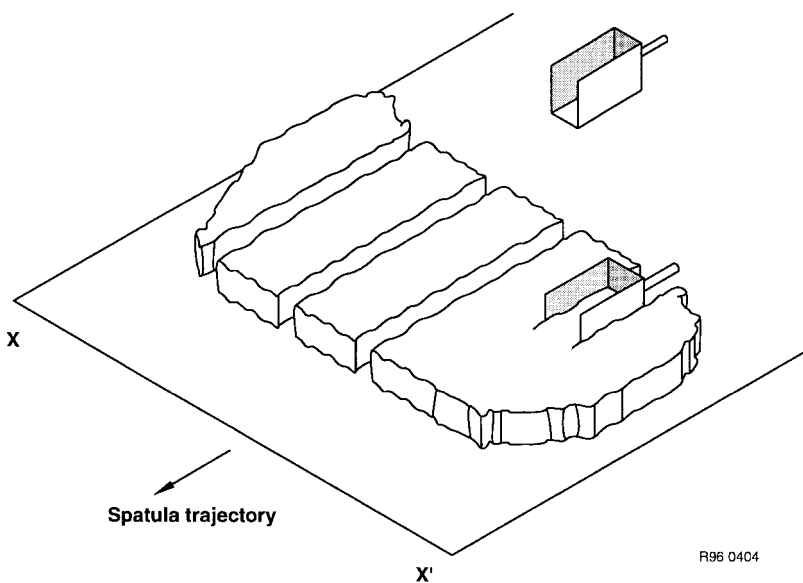

FIG. 1 Transversal Subsampling

R96 0404

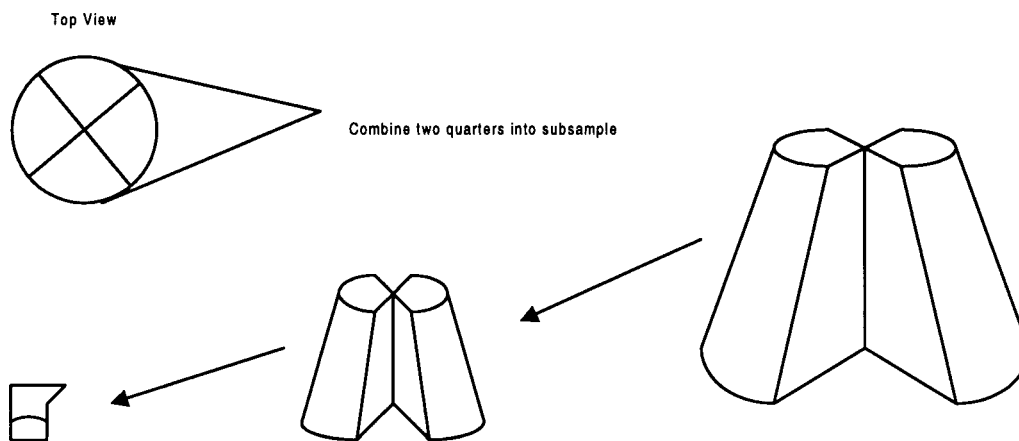

FIG. 2 Cone and Quartering

TABLE 3 Commonly Used Particle Size Reduction Devices for Solids

Device	Manufacturer's Recommended Particle Size or Sample Mass	Reduced to	Uses of
Cutting Mill	50 mm or less	Almost any size depending on mill	Foliage, grains, soils
Micro-Mill	20 to 50 mg	Almost any size depending on mill	Can be temperature controlled
Centrifugal cutting mill	3 to 100 g	40 μm	Chemicals, coal, seeds, plant stems, polypropylene or polyester.
Jar mill	pint to 2 gal	Almost any size depending on material and time	Can be used wet or dry
Horizontal and Vertical Disc Mills	5 to 20 mm particle size	250 to 1000 μm	Chemicals, clay, foods, plants, leather, cardboard
Dish and puck mill	10 g to 5 kg	10 to 100 μm	Brick, cement, chemicals, coal, coke, glass, minerals, ore, plants, rock, metals, sand, slag, soil
Mortar grinders	1 to 8 mm particle size	5 μm to 8 mm	Can be used wet or dry, organic or inorganic substances
Jar Crushers	1 to 100 mm particle size	1 to 40 mm	Medium hard, brittle, and tough materials, for example, chemicals, coke, concrete, glass, coal, gravel, quartz, slag.

4). The entire laboratory sample is emptied out onto a non-contaminating smooth surface. Material is piled into a cone with a flattened top surface. Two top-to-bottom cuts are made through the cone at perpendicular angles to form four equal portions, or quarters. Two opposite quarters are compiled into a new cone, and the process is repeated until the proper sample mass is achieved. See C 702 for more information.

6.1.9.3 *Riffle Splitter* (see Fig. 3)—A riffle splitter is a mechanical device with an equal number of narrow sloping chutes (2). Alternate chutes discharge the sample into opposite directions into two collection pans. Subsampling is achieved by pouring the entire laboratory sample into the riffle splitter. One portion is removed, and the collection pan is replaced with a clean pan. This portion is poured back through the riffle splitter so that half of the subsample will combine with the original material, and the other half will drop into the clean collection pan. This process is repeated until the proper sample mass is achieved. There are many types of riffle splitters available. The analyst must select the one that meets the data

user's needs. The riffle splitter opening should be about three times the largest particle diameter, and have an even number of chutes.

6.1.9.4 *Alternate Scoop*—This method is discussed in Guide 6051. Scoops of the mixed laboratory sample are either placed in the analytical vessel, or discarded. In the example in Fig. 4, three scoops are discarded for every scoop saved. Care should be taken that each scoop of material is of the same size and is taken in a consistent manner to minimize bias.

6.1.9.5 *Sectorial Splitter (Sample Divider)*—(See Fig. 5)—This is a spinning riffle-type sample divider. The sample is placed in the opening, and the material is vibrated through shoots to the spinning bottles. The specimen may be taken directly from the bottle, or it may be further subsampled by discarding every other bottle, placing the remaining sample back in the opening, and starting the process over again.

6.1.10 *Laboratory Sample Particle Size Greater Than the Allowable Particle Size and the Contaminant Unit Less Than the Allowable Particle Size:*



TABLE 4 Limitations and Features of Subsampling, Mixing, and Grinding Methods

Method	Type of Method	Limitations	Unique Features
Transversal Subsampling	Subsampling	(1) Possible sample loss due to the inability to recollect all of the soil from the underlying material, (2) Development of static electricity may cause a loss of fine particles, (3) Particle size bias if a square scoop is not used, (4) Method may affect sample moisture content.	(1) Minimizes discrimination between particle sizes, (2) Ease of decontamination of equipment.
Cone and Quartering	Subsampling	(1) Possible sample loss due to the inability to recollect all of the soil from the underlying material, (2) Development of static electricity may cause a loss of fine particles, (3) May introduce large biases from the grouping and segregation error, (4) Possible unequal segregation of heavy and fine particles, (5) Method may affect sample moisture content.	Ease of decontamination of equipment.
Alternate Scoop	Subsampling	(1) Possible sample loss due to the inability to recollect all of the soil from the underlying material, (2) Development of static electricity may cause a loss of fine particles, (3) Particle size bias if a square scoop is not used, (4) Bias may occur if each scoop is not of the same size or if not taken in a consistent manner, (5) Method may affect sample moisture content.	(1) Minimizes discrimination between particle sizes, (2) Ease of decontamination of equipment, (3) Simpler than Transversal Subsampling, since there is no need to shape the pile.
Sectorial Splitter (Sample Divider)	Subsampling	(1) Limited to use with small particle sizes (about 6 mm), (2) May be difficult to decontaminate, (3) Method may affect sample moisture content.	(1) Minimizes discrimination between particle sizes, (2) Proper use eliminates most biases, (3) Simple to use, mechanical device.
Riffle Splitting	Subsampling or Mixing	(1) Possible loss of fine particles due to dusting when the sample is introduced, (2) May introduce biases from the grouping and segregation error, (3) Some riffle splitters are difficult to decontaminate.	(1) Proper use eliminates most biases, (2) Many choices in size available from manufacturers, including closed or open systems.
Grinding and Sieving/Mills/Jaw Crushers	Grinding	(1) Development of static electricity may cause a loss of fine particles, (2) Possible loss of fine particles due to dusting when the sample is introduced into the grinder, or the sieve, (3) Increasing the surface-to-mass ratio, which may effect the leachability during partial digestion or extraction, (4) Grinding equipment may be difficult to decontaminate, (5) Grinding and sieving may be labor intensive.	(1) Simple method to reduce particle size, (2) Many choices in size and type available from manufacturers.
Mixing Squares	Mixing	(1) Mixing sheet must not be made of material that will contaminate samples, (2) Development of static electricity may cause a loss of fine particles.	(1) Non-mechanical method of mixing, (2) Cost efficient, (3) Ease of decontamination of equipment.
Mechanical Mixers	Mixing	(1) Possible segregation of heavy versus light, or large versus small particles, (2) Some mixers are difficult to decontaminate.	Simple method to evenly distribute particles in solids that are difficult to mix by hand.

6.1.10.1 If the data user can accommodate worst-case, such as biased-high concentration of the parameter of interest, then subsampling can be performed without the need for large sample masses or particle size reduction. The procedure described in 6.1.11.1 will work, except that the particles larger than the allowable particle size are removed from the transversal section prior to addition to the subsample.

6.1.10.2 If the data user cannot accommodate worst-case, refer to 6.1.11.

6.1.11 Laboratory Sample Particle Size and Contaminant Unit Larger than the Allowable Particle Size:

6.1.11.1 Since the contaminant is associated with the large particles in this type of laboratory sample, the option of selectively removing large particles is not viable. Optimum solutions would be to increase the sample mass, or reduce the particle size. If these methods are not practical, a multiple subsample approach may be employed. Ideally, enough of these subsamples will be analyzed or extracted so that the desired sample mass is achieved. The subsamples will then be subjected to preparation for analysis, such as solvent extraction

or acid digestion. The resulting extracts or digestates can be analyzed separately and the results can be weight-averaged, or the extracts may be combined prior to analysis.

6.1.11.2 *Grinding or Milling*—A alternate method to increasing the sample mass is particle size reduction. This includes such methods as grinding or milling. Grinding can be achieved by hand methods, such as a mortar and pestle, and by using such mechanical devices as mills, grinders, or jaw crushers. Table 3 contains a list of commonly used devices that are commercially available.

6.1.11.3 Each device can be constructed out of different materials to prevent contamination of the laboratory sample.

6.1.11.4 Once particle size reduction has stopped, the laboratory sample should be poured through a sieve into a pan to demonstrate that the desired particle size has been achieved.

6.1.11.5 The sample should be reground if it doesn't go through the sieve. The subsample is then obtained from the sieved material using one of the methods outlined in section 6.1.9

6.1.12 The limitations of each method discussed in 6.1.11

ASTM D 6323

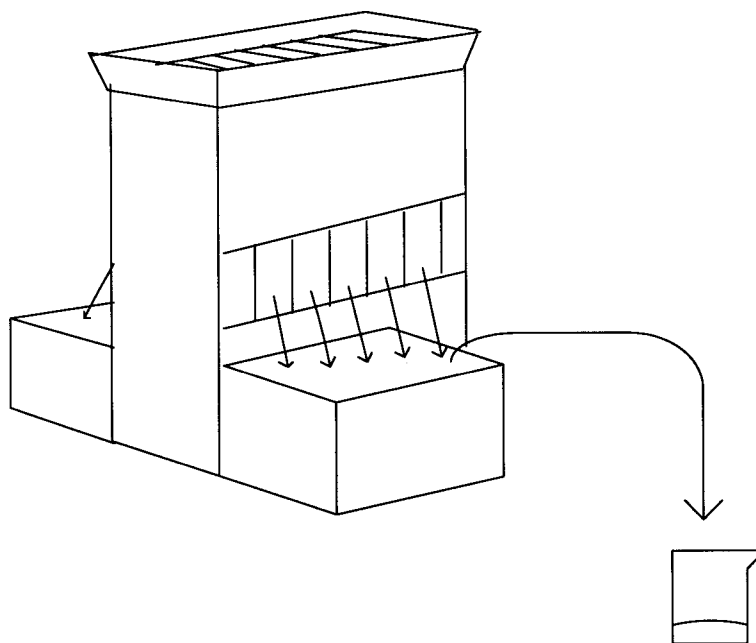

FIG. 3 Riffle Splitter

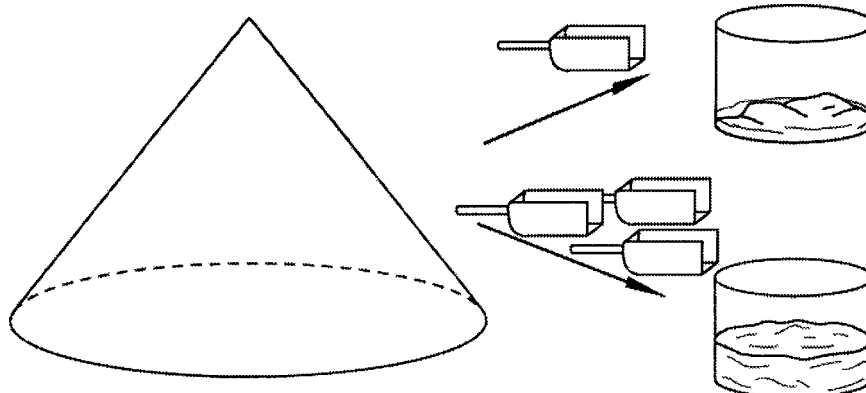

FIG. 4 Alternate Scoop

must be considered before subsampling begins. Table 4 discusses the limitations of each of these methods.

6.1.13 *Mixing*—To reduce heterogeneity, a sample or subsample must be mixed prior to removing the specimen. However, care should be taken since mixing may actually increase the variance. For example, if a subsample had lead shot in soil, differences in size, shape and density may increase heterogeneity further by the development of different strata upon agitation or vibration of the sample.

6.1.14 Mixing techniques are included in the following section.

6.1.14.1 Mixing of a subsample may be achieved manually, or by the use of a mechanical mixer. Manual methods can include stirring with a spatula for 2 to 3 min, until the sample appears uniform, or use of a mixing square. A mixing square is a non-contaminating square sheet, such as Teflon. The laboratory sample is poured into the middle of the sheet, and a rolling pin is used to roll the sample backward and forward while alternately lifting and releasing opposite side corners of the sheet. (See Refs (3) and (4)).

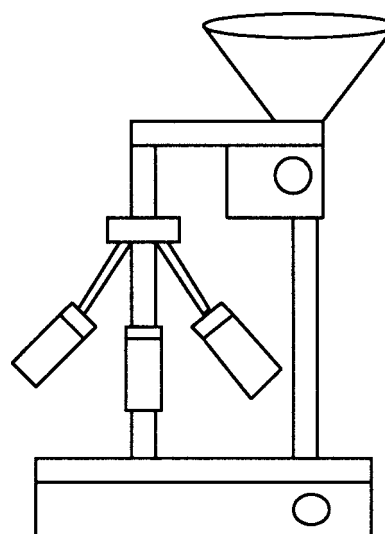

FIG. 5 Sectorial Splitter

6.1.14.2 Mixing can be attained by using a variation of the riffle splitting method. After the laboratory sample is poured through the riffle splitter, the halves are combined, and re-introduced through the riffle splitter a minimum of five times.

6.1.14.3 A variation of the cone and quartering method can be used to homogenize flowable solid samples. After the material is quartered, the first portions removed from the pile is re-formed into a cone. Each of the other portions is poured onto the cone, and the process is repeated a minimum of five times.

6.1.14.4 Mechanical methods of mixing include a spiral mixer, a cement mixer, or a twin-shell V blender, and mills.

6.2 Liquids:

6.2.1 Some analytical methods, such as oil and grease analyses, require the analyst to use the entire laboratory sample as the specimen. This field sample should arrive at the laboratory in a proper sized bottle. After removing the specimen, the bottle is rinsed with an appropriate solvent to assure transfer of the entire sample from the container to the analytical vessel. Occasionally, a field sample may arrive at the laboratory in an improper container. If this happens, the data user should be contacted for a resample. If the data user decides to go ahead with the inappropriately sized field sample, the analyst should remove the specimen from the container, and the rest of the original laboratory sample should be transferred into another container. The ratio of specimen to remaining material must be measured. The sides of the container are then rinsed with the appropriate material for the analysis being performed. The specimen and rinsate may be either analyzed separately and weight averaged, or the ratio measured above could be used to determine the amount of rinsate to add to the specimen and it could be analyzed directly.

6.2.2 Liquid Samples for Volatile Analyses:

6.2.2.1 Aqueous laboratory samples for volatile compounds should not be mixed prior to subsampling. Transfer appropriate volume for analysis using techniques that minimize loss, such as a syringe.

6.2.2.2 Subsampling of a non-aqueous solution for volatile compounds is often the first step in a sample dilution process which is necessary to prevent saturation and contamination of analytical instrumentation and to get sample concentrations within the calibrated concentration range. Due to the usually large dilution factors, an appropriate technique, such as the use of a microliter syringe, is used to obtain a subsample. The subsample is then transferred to a solvent appropriate for analysis, such as methanol, in an air-tight container.

6.2.3 Liquid Samples for Non-Volatile Analyses:

6.2.3.1 Aqueous solutions for non-volatile compounds may contain settleable materials. If the settleable materials are to be included as part of the laboratory sample, and they will remain suspended, or can easily be re-suspended and will remain so during the subsampling operation, the sample should be handled as a liquid sample. These laboratory samples should be gently swirled for 15 s or slowly inverted six times to reduce heterogeneity.

6.2.3.2 If the analyst is subsampling the liquid portion only, the settleable material must be allowed to sink to the bottom before withdrawing the subsample from the liquid portion. The liquid subsample or specimen may be obtained by filtering,

centrifuging, or decanting the liquid portion from the solid portion, or by pipetting only the liquid portion directly into the analytical vessel.

6.2.3.3 If the settleable material will not remain suspended, and is to be included in the analysis, the sample should be treated as a multilayered sample (see 6.3).

6.2.3.4 Single-layer aqueous laboratory samples should be gently swirled for 15 s or slowly inverted 6 times to reduce heterogeneity. Remove appropriate subsample for analysis.

NOTE 3—Caution: The container should be vented periodically to release any pressure that may be developed during mixing.

6.2.3.5 The subsampling process for a non-aqueous solution for non-volatile compounds is the same as the process for an aqueous solution.

6.3 Multilayered Samples:

6.3.1 Multilayered samples consist of two or more clearly differentiated components. These may include liquid/liquid layers, such as chlorinated solvents and water, or water and oil. They may be liquid/solid samples, such as sludge. They may be solid/solid samples, such as pea gravel and sand. Or they may include combinations of these materials, such as a mixture of oil, water, and sludge.

6.3.2 If the liquid portion of a sludge is so small that it can be re-mixed with the solid portion and will only re-separate over time, the sample should be handled as a solid sample (see 6.1).

6.3.2.1 If the solid portion of a sludge will remain suspended, or can easily be re-suspended and will remain so during the subsampling operation, the sample should be handled as a liquid sample. These laboratory samples may be mixed by inverting the container, or with slight shaking (see 6.2).

6.3.3 One method of subsampling multilayered laboratory samples is to separate them into their component layers. Layers may be either physically separated, or individually subsampled from the original container. The individual layers can be analyzed separately and the weighted average calculated. Portions of the separate phases can be proportionally recombined, either in the analytical vessel for non-volatile analyses, or directly on a purge unit during volatile analysis to form a representative specimen.

6.3.4 Multilayered Samples for Volatile Analysis/Separation of Layers:

6.3.4.1 For liquid/liquid layers, transfer appropriate volume for analysis using techniques that minimize loss, such as a syringe or a pipette, from each layer.

6.3.4.2 If laboratory samples have significant solid and liquid layers that cannot be mixed vigorously enough to suspend a solid phase without the potential of losing volatile components, materials may be separated into their component phases. The solid/liquid phase separation may be achieved by gently centrifuging the unopened container, or by allowing it to sit undisturbed until the solid portion is settled. The percentage of each phase should be determined, either by volume or weight.

6.3.4.3 Transfer appropriate mass for analysis using techniques that minimize loss, such as syringe or a pipette. Decant the remaining liquid into another container.

6.3.4.4 A specimen of the remaining solid phase is weighed

 **D 6323**

for analysis. See 6.1.4 for more information.

6.3.5 Multilayered Samples for Non-Volatile Analyses/ Separation of Layers:

6.3.5.1 For liquid/liquid layers, separate the layers using techniques such as a separatory funnel or pipette. Each layer of the material may either be transferred into another container, or directly into the analytical vessel. Each separated portion is then handled as a homogeneous liquid sample. See 6.2.3 for more information.

6.3.5.2 For liquid/solid layers, the liquid subsample or specimen may be obtained by filtering, centrifuging, or decanting the liquid portion from the solid portion, or by pipetting the liquid portion directly into the analytical vessel. The liquid portion is then handled as a homogeneous liquid sample. The solid portion is handled as a solid laboratory sample.

6.3.6 Alternative Methods for Multilayered Samples for Non-Volatile Analyses—An alternative method of subsampling liquid/solid samples is to freeze the material (see Guide D 4823).

6.3.6.1 The laboratory sample is transferred into a rectangular box and the solids are allowed to settle. Dry ice or liquid nitrogen can be used to freeze the material. The container may also be placed in a freezer until frozen. Subsamples are sliced

out of the box through all the layers. This subsample or specimen is then treated as a solid.

6.3.6.2 An alternate freezing method is to place the laboratory sample into an appropriate container. The whole sample is then frozen using dry ice or liquid nitrogen, and the subsample is obtained using methods described in 6.1.11.

6.3.6.3 An important technique in sampling liquid/solid samples is continuous agitation during the subsampling process. This can be applied to the subsampling of non-volatile compounds for laboratory samples that are pre-dominantly liquid or have liquid characteristics. This is particularly useful for laboratory samples that can form a semi-emulsified form, but only with continuous agitation. During the mixing process, remove an appropriate specimen from the original laboratory sample for analysis.

6.3.7 Solid/solid samples may be subsampled according to 6.1 of this guide.

6.3.8 One or more of the previous methods can be utilized to subsample multilayered samples, depending on how many layers are encountered in the sample.

7. Keywords

7.1 sample preparation; subsampling; waste

ANNEX

(Mandatory Information)

A1. CONSIDERATION OF FUNDAMENTAL ERROR IN THE DETERMINATION OF APPROPRIATE SUBSAMPLE MASS

A1.1 The Table A1.1 is a guide for the maximum allowable particle sizes (centimetres) that can be accommodated by a given subsample mass (grams) with a specified percent relative standard deviation accrued from fundamental error alone. This table is based on the equation for fundamental error as described in Ramsey et al. (5). The tabularized data were generated using the following equation:

$$S^2 = 18 * f * e * d^3 / M_s \tag{A1.1}$$

where:

- S^2 = the relative variance of the contaminant concentration due to the fundamental error,
- S = the relative standard deviation of the contaminant concentration due to the fundamental error,
- f = a dimensionless factor related to particle shape (a value of 0.5 can be taken as typical, Gy, 1982 (6)),
- e = the population's average density (g/cm^3). An average density is assumed to be $2.5 \text{ g}/\text{cm}^3$,
- d = the diameter of the largest particle in centimetres, and
- M_s = the mass of the sample in grams.

TABLE A1.1 Maximum Allowable Particle Size (Centimetres) that can be Accommodated by a Given Subsample Mass at Various % Relative Standard Deviation (RSD)

Recommended Subsample Mass, (g)	U.S. Standard Sieve Mesh Size	5 % RSD	10 % RSD	15 % RSD
0.1	35	0.02	0.04	0.05
1	18	0.05	0.08	0.10
2	13	0.06	0.10	0.13
5	12	0.08	0.13	0.17
10	10	0.10	0.16	0.22
30	7	0.15	0.24	0.31
50	6	0.18	0.28	0.37
100	5	0.22	0.35	0.46

A1.2 Using the above assumptions for density and the shape factor this equation can be rearranged to calculate the largest particle size that can be representatively accommodated by a given subsample mass and given fundamental error.

$$d = \sqrt[3]{(M_s / 22.5) * S^2} \tag{A1.2}$$

A1.3 If the density of the material being sampled varies significantly from $2.5 \text{ g}/\text{cm}^3$, then the actual density should be employed. If the material being sampled does not have a

 **D 6323**

typical shape, the factors in Table A1.2 can be substituted for the 0.5 value used to calculate the tabularized data (1).

TABLE A1.2 “f” Values for Different Particle Shapes

Particle Shape	f
Cubic	1
Spheres	0.5
Flakes	0.1
Soft solids shaped by mechanical stress	0.2
Needles	> 1 to ≤ 10

A1.4 Table A1.1 summarizes the maximum allowable particle size in centimetres that can be accommodated by a given subsample mass at varying fundamental errors. The tighter the required precision, the larger the sample mass. This table assumes that the particle is the typical shape described above by Gy, and serves as an example of how the maximum allowable particle size changes as a function of these parameters. It is important to note that the fundamental error should be no larger than 15 % (1).

REFERENCES

- (1) Pitcard, Francis F., *Pierre Gy's Sampling Theory and Practice*; 2nd Edition, CRC Press, Inc., Boca Raton, FL, 1993.
- (2) Simmons, Milagros S., *Hazardous Waste Measurements*, Lewis Publishers, 200 Corporate Blvd., NW, Boca Raton, FL, 1991.
- (3) US-EPA, *Description and Sampling of Contaminated Soils, A Field Pocket Guide*, EPA/625/12-91/002, 1991.
- (4) Boulding, J.R., *Description and Sampling of Contaminated Soils: A Field Guide*, Lewis Publishers, 2000 Corporate Blvd., NW, Boca Raton, FL, 1994.
- (5) Ramsey, Charles A., Ketterer, Michael E., and Lowry, Joe H., “Application of Gy’s Sampling Theory to the Sampling of Solid Waste Materials,” In *Proceedings of the EPA Fifth Annual Waste Testing and Quality Assurance Symposium*, Vol 11, Washington, DC, July 24-28, 1989, pp. 11-494.
- (6) Gy, P.M., *Sampling of Particulate Material*, Elsevier, Amsterdam, 1982.

The American Society for Testing and Materials takes no position respecting the validity of any patent rights asserted in connection with any item mentioned in this standard. Users of this standard are expressly advised that determination of the validity of any such patent rights, and the risk of infringement of such rights, are entirely their own responsibility.

This standard is subject to revision at any time by the responsible technical committee and must be reviewed every five years and if not revised, either reapproved or withdrawn. Your comments are invited either for revision of this standard or for additional standards and should be addressed to ASTM Headquarters. Your comments will receive careful consideration at a meeting of the responsible technical committee, which you may attend. If you feel that your comments have not received a fair hearing you should make your views known to the ASTM Committee on Standards, at the address shown below.

This standard is copyrighted by ASTM, 100 Barr Harbor Drive, PO Box C700, West Conshohocken, PA 19428-2959, United States. Individual reprints (single or multiple copies) of this standard may be obtained by contacting ASTM at the above address or at 610-832-9585 (phone), 610-832-9555 (fax), or service@astm.org (e-mail); or through the ASTM website (www.astm.org).