



Designation: C 1075 – 93 (Reapproved 1997)

Standard Practices for Sampling Uranium-Ore Concentrate¹

This standard is issued under the fixed designation C 1075; the number immediately following the designation indicates the year of original adoption or, in the case of revision, the year of last revision. A number in parentheses indicates the year of last approval. A superscript epsilon (ε) indicates an editorial change since the last revision or reapproval.

1. Scope

1.1 These practices are intended to provide the nuclear industry with procedures for obtaining representative bulk samples from uranium-ore concentrates (UOC) (see Specification C 967).

1.2 These practices also provide for obtaining a series of representative secondary samples from the original bulk sample for the determination of moisture and other test purposes, and for the preparation of pulverized analytical samples (see Test Methods C 1022).

1.3 These practices consist of a number of alternative procedures for sampling and sample preparation which have been shown to be satisfactory through long experience in the nuclear industry. These procedures are described in the following order.

Stage	Procedure	Section
Primary Sampling	One-stage falling stream	4
	Two-stage falling stream	5
	Auger	6
Secondary Sampling	Straight-path (reciprocating)	7
	Rotating (Vezin)	8, 9
Sample Preparation		10
	Concurrent-drying	11-13
	Natural moisture	14-16
Sample Packaging	Calcination	17, 18
		19
	Wax sealing	20
	Vacuum sealing	21

1.3.1 The primary and secondary sampling stages can be organized in the following way:

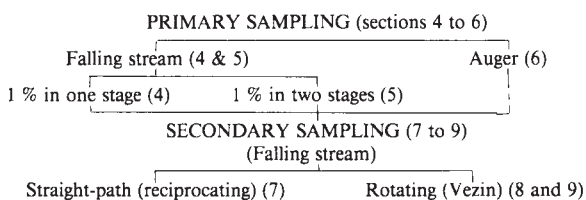

1.3.2 It is possible to combine the various elements of these stages in different ways to give satisfactory results depending on the agreed requirements of the contracting parties. For a

given stage, however, each procedure must be regarded as a whole. It is highly inadvisable to mix elements belonging to different procedures.

1.4 These procedures do not include requirements for health, safety, and accountability. The observance of these practices does not relieve the user of the obligation to be aware of and to conform to all applicable international, federal, state, and local regulations pertaining to processing, shipping, or using uranium-ore concentrates. (Guidance is provided in CFR, 10, Chapter 1.)

1.5 The values stated in SI units are to be regarded as the standard. The values given in parentheses are for information only.

1.6 *This standard does not purport to address all of the safety problems, if any, associated with its use. It is the responsibility of the user of this standard to establish appropriate safety and health practices and determine the applicability of regulatory limitations prior to use.*

2. Referenced Documents

- 2.1 *ASTM Standards:*
 C 967 Specification for Uranium Ore Concentrate²
 C 1022 Test Methods for Chemical and Atomic Absorption Analysis of Uranium-Ore Concentrate²
- 2.2 *Other Document:*
 CFR 10 Nuclear Materials Licensing Code of Federal Regulations, Chapter 1³

3. General Requirements

3.1 Material Requirements:

3.1.1 The uranium-ore concentrates shall be free-flowing and of a particle size not to exceed 6 mm (0.25 in.) or such other limit agreed upon between contracting parties.

3.1.2 The average moisture content shall not exceed 5.0 % weight of the uranium-ore concentrates.

3.1.3 The material shall be shipped to the sampling plant in 200-L (55-gal) standard steel drums that are fitted with steel lids and equipped with suitable gasket and sealing rings to ensure weatherproofing. The drums shall be constructed so that the top of the drum is fully open when the lid is removed.

¹ These practices are under the jurisdiction of ASTM Committee C26 on Nuclear Fuel Cycle and are the direct responsibility of Subcommittee C26.02 on Fuel and Fertile Material Specifications.

Current edition approved April 15, 1993. Published June 1993. Originally published as C 1075 – 86. Last previous edition C 1075 – 86.

² *Annual Book of ASTM Standards*, Vol 12.01.

³ Available from Superintendent of Documents, U.S. Government Printing Office, Washington, DC 20402.

3.1.4 The number of drums in a sampling lot shall not exceed 90 and the gross weight shall not exceed 45 metric tons (100 000 lb).

3.1.5 A minimum number of drums in a sampling lot may be established depending upon the sampling procedure used.

3.2 Sampling Equipment Requirements:

3.2.1 Care shall be taken in the design and operation of the sampling and all associated equipment to minimize the exchanges of air between the atmosphere and the sampling system. For obvious safety reasons dust-carrying internal air must be prevented from escaping the system. This is achieved by means of dust collectors. The latter, however, shall be designed and operated in such a way that a minimum amount of external air shall be allowed into the system. The purpose of this is (1) to limit the exchanges of moisture between the atmosphere and the UOC and (2) to prevent a size-selective dedusting. In any case, the amount of dust escaping the sampling operations must be kept to a minimum.

3.2.2 The scales for the gross and tare weighings of the drums shall be capable of reading to the nearest 0.2 kg (0.5 lb) and shall be fitted with a print-out or data processing system, or both. They shall have a capacity of 600 kg (1300 lb). The weigh scale shall be calibrated and adjusted if required, at the beginning, middle, and end of each lot weighed. Test weights shall be certified by a statutory authority and shall be traceable to national or state standards.

3.2.3 All sampling containers shall be clean and dry before usage.

4. Primary Sampling, Falling Stream—1 % In One Stage

4.1 *Scope*—The falling-stream procedure provides for removing a large number of increments of the material as it falls

freely at a uniform, controlled rate. All of the material in a lot passes through the system and is subject to incremental sampling.

4.2 Sampling Equipment Requirements:

4.2.1 A schematic diagram of a typical falling-stream sampling facility is shown in Fig. 1. Subsequent procedures are described by reference to this equipment.

4.2.2 The flow of material through the falling-stream system shall be controlled by a rotary valve discharging to the hopper or pan of the first stage vibrating feeder. The rate of flow should not exceed $4.5 \times 10^{-2} \cdot \text{m}^3$ (1.6 ft³)/min and also should be controlled so that the cutter obtains from the falling stream at least 1 cut/ $2.8 \times 10^{-2} \cdot \text{m}^3$ (1.0 ft³) of material.

4.2.3 The first stage vibrating feeder should be adjusted so that the depth of the material in the trough (pan) does not exceed 50 mm (2.0 in.), and that the entire vertical cross section of the falling stream is totally intercepted by the cutter head.

4.2.4 The samplers should be designed and constructed as follows:

4.2.4.1 Approximately 1 % of the falling stream shall be diverted by the cutter. With small lots (for example, less than 10 tonnes), however, a larger percentage may be implemented in order to fulfill the requirements of the secondary sampling stage.

4.2.4.2 The horizontal linear speed of cutter heads shall not exceed 15 cm (6 in.)/s.

4.2.4.3 The width of the cutter head shall be no less than 30 mm (1.25 in.), that is, a minimum of five times the allowable particle size.

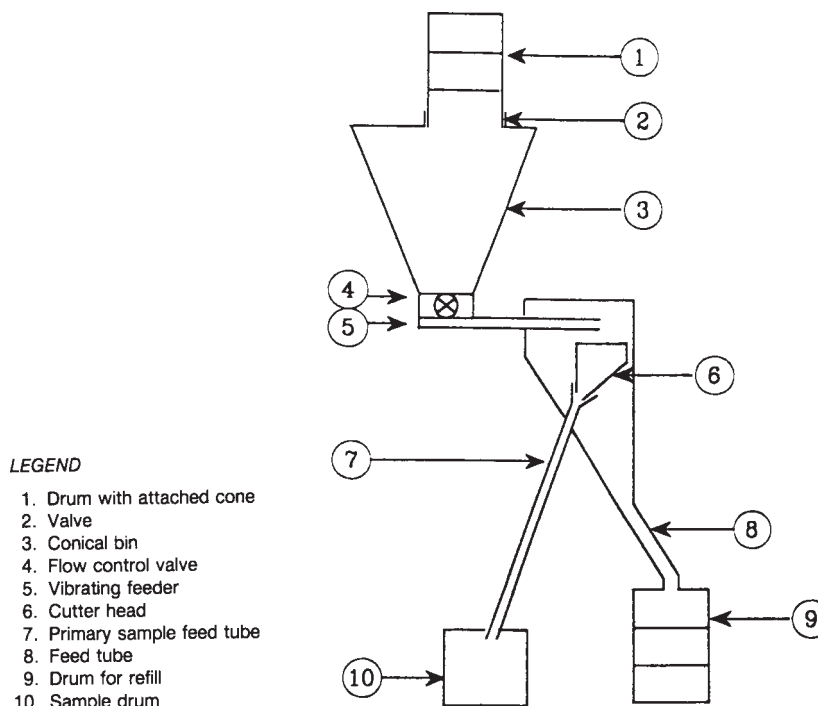

FIG. 1 Schematic Diagram of Falling-Stream Primary Sampler In One Stage

4.2.4.4 It is recommended that the cutter heads be constructed of stainless steel to improve their durability and reliability.

4.2.4.5 The top edges of the cutter heads shall be beveled to form knife edges.

4.3 Procedure for Obtaining the Primary Sample:

4.3.1 Clean and dry the tops of the drums if necessary, transfer them by means of a roller conveyor to the weigh scale, and record the gross weight to ± 0.2 kg (± 0.5 lb).

4.3.2 After the gross weights of the drums in a lot have been obtained, dump the contents of each drum into an elevated bin.

4.3.3 Equip the dumper with a vibrator and a dust collector designed and operated in accordance with 3.2.1.

4.3.4 After the drum is emptied, tare weigh the empty drum, lid, drum ring, and bolt.

4.3.5 Equip the bin into which the drums are dumped such as to facilitate the flow control and the transfer of material from the bin. The bin should have a conical bottom with a discharge opening or a size that will provide the desired flow.

4.3.6 The rotary valve discharge is received on an elongated vibrating feeder that uniformizes the flow rate.

4.3.7 Remove a portion of the falling stream and receive it in a convenient surge bin mounted on a weighing system.

4.3.8 The contents of the surge bin are then fed to the secondary sampling system (see Sections 7-9).

4.3.9 Let the material not diverted by the cutter fall freely into a second bin from which the drums may be refilled if so desired.

5. Primary Sampling, Falling Stream—1 % In Two Stages

5.1 *Scope*—The falling-stream procedure provides for removing a large number of increments of the material as it falls freely at a uniform, controlled rate. All of the material in a lot passes through the system and is subject to incremental sampling.

5.2 Special Sampling Equipment Requirements:

5.2.1 A schematic diagram of a typical falling-stream sampling facility is shown in Fig. 2. Subsequent procedures are described by reference to this equipment.

5.2.2 The flow of material through the falling-stream system shall be controlled by a rotary valve discharging to the hopper or pan of the first stage vibrating feeder. The rate of flow should not exceed $4.5 \times 10^{-2} \cdot \text{m}^3$ (1.6 ft³)/min and also should be controlled so that the cutter obtains from the falling stream at least 10 cuts/ $2.8 \times 10^{-2} \cdot \text{m}^3$ (1.0 ft³) of material.

5.2.3 The first stage vibrating feeder should be adjusted so that the depth of the material in the trough (pan) does not exceed 50 mm (2.0 in.), and that the entire vertical cross section of the falling stream is totally intercepted by the cutter head.

5.2.4 The samplers should be designed and constructed as follows:

5.2.4.1 Approximately 10 % of each falling stream shall be diverted by each cutter.

5.2.4.2 The horizontal linear speed of cutter heads shall not exceed 15 cm (6 in.)/s.

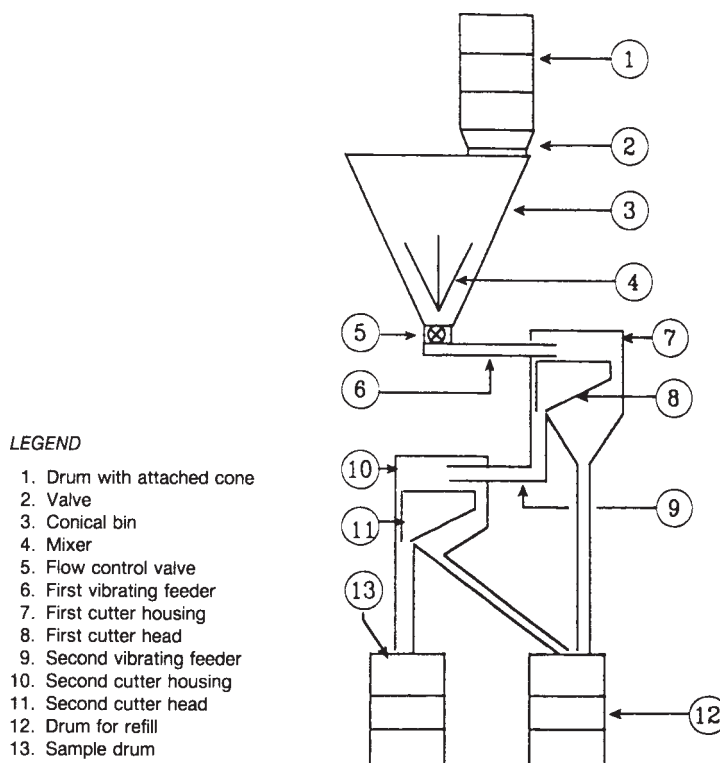

FIG. 2 Schematic Diagram of Falling Stream

5.2.4.3 The width of the cutter head shall be no less than 30 mm (1.25 in.), that is, a minimum of five times the allowable particle size.

5.2.5 It is recommended that the cutter heads be constructed of stainless steel to improve their durability and reliability.

5.2.6 The top edges of the cutter heads shall be beveled to form knife edges.

5.3 Obtaining the Primary Sample Procedure:

5.3.1 Clean and dry the tops of the drums if necessary, transfer them by means of a roller conveyor to the weigh scale, and record the gross weight to ± 0.2 kg (± 0.5 lb).

5.3.2 After the gross weights of the drums in a lot have been obtained, dump the contents of each drum into an elevated bin.

5.3.3 Equip the dumper with a vibrator and a dust collection designed and operated in accordance with the conditions of 3.2.1.

5.3.4 After the drum is emptied, tare weigh the empty drum, lid, drum ring, and bolt.

5.3.5 Equip the bin into which the drums are dumped such as to facilitate the flow control and the transfer of material from the bin. The bin should have a conical bottom with a discharge opening of a size that will provide the desired flow.

5.3.6 Set the rotary valve to deliver approximately 4.2 to 4.5×10^{-2} m³/min (1.5 to 1.6 ft³/min). This rate should not vary during the course of sampling of the entire lot.

5.3.7 Remove a portion of the falling stream and divert it to a second vibrating elongated feeder and cutter of similar design with a reciprocating cutter.

5.3.8 Direct the material diverted by the second stage cutter to a tared primary sample container, and close with a suitable lid depending on the secondary sampling procedure to be used (see Sections 7-9).

5.3.9 Let the material not diverted by the first- and second-stage cutters fall freely into a second bin from which the drums may be refilled if so desired.

5.3.10 Since approximately 10 % of each falling stream is diverted, the primary sample container will contain approximately 1 % of the entire lot. In no instance shall the total sample weight vary more than ± 5 % of the calculated value for the equipment employed.

6. Primary Sampling—Auger Sampling Procedure

6.1 *Scope*—The auger-sampling procedure provides for the removal of a core sample of the material from each drum by means of a tube that contains a rotating auger. Each drum of material passes through the system and is subject to individual sampling.

6.2 Special Equipment Requirements:

6.2.1 The auger sampler shall be designed and constructed so that approximately 0.5 % weight of the ore concentrate is withdrawn from each drum. Experience with a variety of uranium-ore concentrates show that a range from 0.3 to 0.7 % can be expected. A schematic diagram of a typical auger-sampling facility is shown in Fig. 3. Subsequent procedures are described by reference to this equipment.

6.2.2 A tumbler shall be provided that is capable of rotating the sample drum about its axis at approximately 25 r/min. Before the tumbling operation, the sample drum shall be closed with either of the following:

6.2.2.1 A conical top fitted with a flow-control valve if the reciprocating cutter procedure is to be used for secondary sampling, or

6.2.2.2 A plain lid fixed by a metal band and bolt closure if the Vezin procedure is to be used for secondary sampling.

6.2.3 In order to achieve the operating limits required for the auger-sampling system the following design parameters are recommended:

6.2.3.1 The auger shall be constructed of suitable material (for example, tool or stainless steel) and shall have the following dimensions:

(1) *Auger Tube*—The outside diameter shall be 50 to 60 mm (1.968 to 2.375 in.) and the inside diameter shall be 43 mm (2.375 to 1.687 in.).

(2) *Length of Auger Helix Within the Auger Tube*, shall be approximately 1400 mm (55 in.).

(3) *Pitch of Helix*, shall be approximately 25 mm (1 in.) apart.

(4) In operation, the end of the auger should protrude 6 to 25 mm (0.25 to 1.0 in.) below the auger tube.

6.2.3.2 The auger shall be made to have a minimum clearance allowing free rotation within the auger tube. The auger shall be capable of being rotated electrically and, when operating, shall turn at approximately 240 r/min.

6.2.4 The auger sampling system may be used as a single or double facility depending on design. In the latter case, two drums are sampled simultaneously with the two augers feeding a common hopper that discharges by means of a 75-mm (3-in.) flexible tube into a single sample drum of 200-L (55-gal) capacity.

6.3 Obtaining the Primary Sample Procedure:

6.3.1 Clean and dry the tops of the drums if necessary, transfer them by means of a roller conveyor to the weigh scale, and record the gross weight to ± 0.2 kg (± 0.5 lb). Pass the drums to the auger cabinet which shall be fitted with dust extraction and filtration equipment.

6.3.2 Remove the bolt and band from the drum, followed by the lid.

NOTE 1—It may be necessary to carry out preliminary operations outside the cabinet to free bolts, but removal of the lid shall only be done inside the cabinet.

6.3.2.1 Place the lid and band on a transporter running parallel to, and indexed to the drum or otherwise ensure that the lid and drum are matched so that the lid moves with and arrives together with the drum after sampling.

6.3.3 Position the drum so that the auger is at the center, midway to the perimeter, or near the perimeter above the surface of the ore concentrate. Adopt these sampling positions on successive drums in the sequence shown in Appendix X1 to take one sample from each drum.

6.3.4 Raise the drum to be sampled on a mechanical or hydraulic ram to meet the enclosed auger which shall start to rotate as the surface of the powder meets the auger. Control the rise of the drum automatically so that cutoff occurs when the rotating base of the auger is within 12 to 25 mm (0.5 to 1.0 in.) of the bottom of the drum. Take the core samples of concentrate displaced vertically by subsequent samples and spill over the top of the auger tube to be collected in the prepared and

LEGEND

1. Auger drive
2. Hollow auger tube
3. Sight glass
4. Powder valve
5. Auger helix
6. Drum to be sampled
7. Sample drum
8. Hydraulic lifting cradle

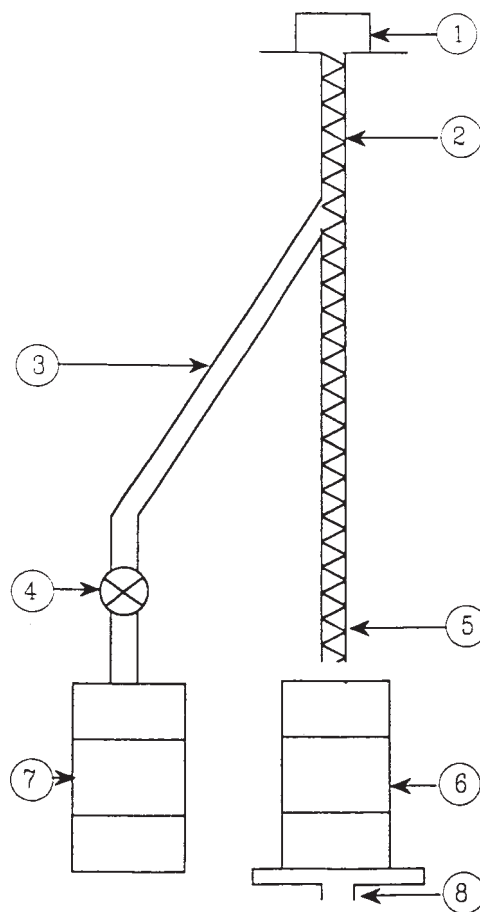

FIG. 3 Schematic Diagram of Auger Primary Sampler

tared sample drum. Combine the sample if two augers are used in parallel, and discharge into a common drum.

6.3.5 Sample a complete lot of concentrate then reverse the rotation of the auger, and displace the concentrate to be collected and add to the sample drum. Close the flow-control valve. Weigh the drum to confirm that the weight of the primary sample is 0.4 to 0.7 % weight of the lot sampled, and record the weight. If the weight is not within the 0.4 to 0.7 % weight range, check whether the auger-sampling system is operating effectively. If defective, correct the fault(s) and resample the lot.

6.3.6 Mix the primary sample by placing the sample drum on a tumbler and rotate at 25 r/min for 15 to 30 min, depending on the experience with particular ore concentrates. When the secondary sampler takes off directly from the primary sample, this operation is not necessary.

7. Secondary Sampling—Straight-Path (Reciprocating) Cutter

7.1 *Equipment*—The basic components of this secondary sampler are the feeder, timer, counter, and sampling unit which contains at least six equally sized trays. The sampling units cut incremental samples of equal weights as the trays intercept the entire falling stream in succession. A schematic diagram of a reciprocating-cutter sample is shown in Fig. 4; the procedures in 7.2 are related to this equipment.

7.2 Obtaining the Secondary Sample Procedure:

7.2.1 This procedure is based on removing a series of samples of equal weight from a variable size primary sample by adjusting the timer controls on a reciprocating sample unit.

7.2.2 Attach the sample drum to the system by means of a conical top and a flow control valve.

7.2.3 Position the drum so that the valve discharges into a vibrating feeder that delivers the falling stream.

7.2.4 Adjust the feed rate to provide a steady flow of concentrate and to assure that a minimum of 100 cuts are taken of the falling stream.

7.2.5 Set the time system to assure that 1500 ± 100 -g samples per tray are obtained. Do not deviate the weights of the samples more than 30 g from the mean.

7.2.6 Collect the falling stream not caught by the cutter unit in a tared drum then seal, and retain until the lot is accepted.

7.2.7 Transfer each of the six samples to sample jars of appropriate volume (about 2 L or 2 qt) and seal immediately.

7.2.8 Number the samples consecutively from one side of the cutter unit to the other.

8. Secondary Sampling—Rotating (Vezin) Cutter

8.1 Equipment:

8.1.1 The basic components of this secondary sampler are a rotating drum cradle, a feed hopper, a vibrating feeder capable of feeding UOC at about 1 kg/min (2.2 lb/min), and the

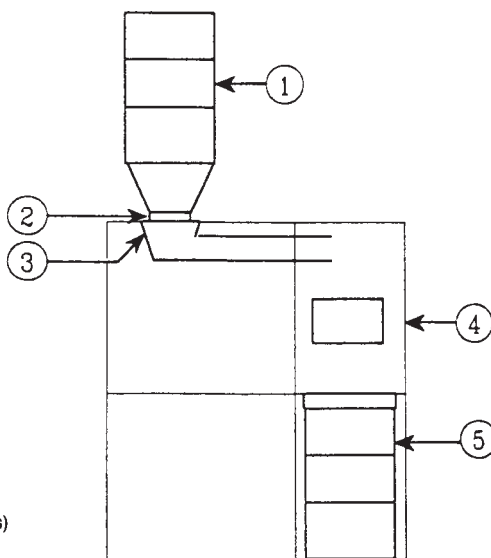

- LEGEND**
- 1. Primary sample drum
 - 2. Flow control valve
 - 3. Vibrating feeder
 - 4. Cutter unit (contains six trays)
 - 5. Reject drum

FIG. 4 Schematic Diagram of Reciprocating-Cutter Secondary Sampler

sampling unit that contains a constant speed rotating cup. A schematic diagram of a Vezin sampler is shown in Fig. 5; the procedures in 8.2 are related to this equipment.

8.1.2 The sampling unit will remove a fixed portion of the primary sample as it falls past the rotating cup.

8.2 Obtaining the Secondary Sample Procedure:

8.2.1 Start the Vezin rotating and switch on the vibrator.

8.2.2 Using a suitable hoist, transfer the sample drum to the cradle in the enclosed tipping cabinet above the Vezin sampler and remove the drum lid.

8.2.3 Tip the contents of the sample drum into the Vezin feed hopper.

8.2.4 Start the Vezin feed screw, located between the base of the hopper and the Vezin feed tube.

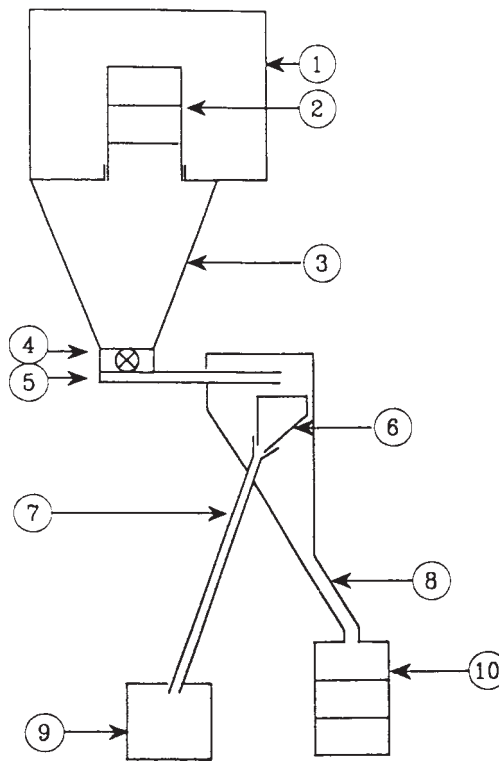

- LEGEND**
- 1. Drum tipping cabinet
 - 2. Primary sample drum
 - 3. Conical bin
 - 4. Powder valve
 - 5. Vibrating feeder
 - 6. Rotating Vezin sampler
 - 7. Secondary sample feed tube
 - 8. Reject sample feed tube
 - 9. Secondary sample collector
 - 10. Reject sample drum

FIG. 5 Schematic Diagram of Vezin Secondary Sampler

8.2.5 Collect the sample material in a suitable tared container, seal, and weigh. The weight should be equivalent to 4.5 to 7.0 % of the primary sample. Collect the Vezein rejected material in a clean tared drum, seal, and retain until the lot sampling is completed.

8.2.6 Split the sample material either directly into a minimum of six portions and place in appropriate size sample jars or homogenize further. In the latter case, transfer to a ball mill or disk-grinder fitted with an off-take mesh with 0.25-mm (0.01-in.) apertures (U.S. Sieve 60 mesh). Blend to assure complete homogeneity and subdivide into a minimum of six portions, place in appropriate size sample jars, and then close. Number these samples arbitrarily to equate to the sample numbers from the reciprocating cutter procedure in 7.2.8.

9. Secondary Sampling—Rotating (Vezein) Cutter Multi-Sampler

9.1 Equipment:

9.1.1 The basic components of this secondary sampler are the primary sample container tightly shut by powder valve, an adapter ring opening on the trough of a vibrating feeder capable of achieving a flow rate of 5 kg/min (11 lb/min) and a multi-sample sampling system (multi-sampler) capable of taking at least four samples, each representing approximately 1 % of the primary sample weight. A schematic diagram is shown on Fig. 6; the procedures in 9.2 are related to this equipment.

9.1.2 The multi-sampler will remove in a single operation at least four twin 1 % samples numbered from 1 to 4.

9.2 Obtaining the Secondary Sample Procedure:

9.2.1 The primary sample container apex is equipped with a rotary vane feeder the purpose of which is to regulate the flow-rate and prevent draughts. It opens into a vibrating feeder that discharges the UOC to the secondary multi-sampler. The latter is a rotating splitter of the Vezein type equipped with four 3, 6° openings whose edges converge towards the rotation axis of the system. Seen from above they form a sort of Malta-cross. This multi-sampler runs continuously and each of the four cutter openings intercepts the primary sample flow during 1 % (3, 6°/360°) of the flowing time, thus achieving a 1 % sampling ratio.

9.2.2 Start the multi-sampler rotating, switch on the vibrating feeder and then the rotary vane feeder.

9.2.3 Collect the four samples in four tared containers of suitable capacity and the secondary sampling reject in a clean, dry, tared standard drum, which is tightly sealed as soon as the secondary sampling is completed.

9.2.4 Two opposed secondary samples, for example, n° 1 and 3, are intended for the determination of uranium content, after suitable preparation in accordance with Section 10. Secondary sample n° 2 is prepared for determination of impurities. Secondary sample n° 4 is immediately transferred into a jar of suitable capacity which is hermetically sealed and

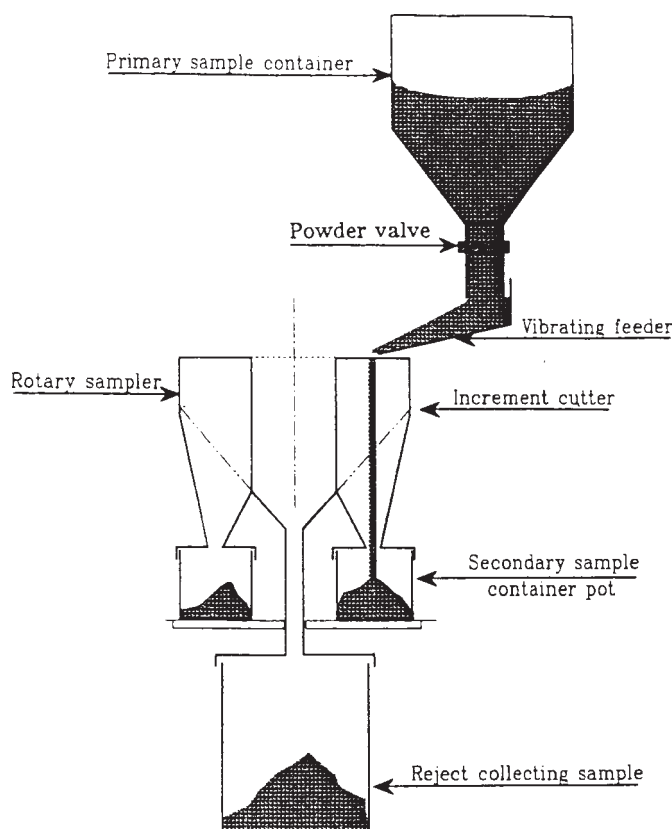

FIG. 6 Secondary Multi-Sampling System

to which leaden seals are affixed. The latter sample is kept as a witness in case such a sample would be required in the future.

10. Sample Preparation

10.1 The practice of sample preparation depends on the objective to be achieved in relating the analysis of the samples to agreed standard conditions, specified under contractual requirements.

10.1.1 Generally, the primary objective is to establish the relationship between the UOC sample obtained from the complete primary and secondary sampling procedure and the dry UOC. The selection of the concurrent-drying or natural-moisture procedure is dependent upon the performance of a test sample. Secondary sample number one is heated to 110°C (230°F) for 24 h under ambient humidity conditions. If the test sample loses weight the concurrent-drying procedure is used.

10.1.2 If the test sample gains weight or shows no change in weight the natural-moisture procedure is used.

NOTE 2—In some cases, it is necessary to establish the relationship between the UOC as received in the drum and the UOC sample obtained from the complete primary and secondary sampling procedures. In such cases, grab samples of the UOC as received in the drum are exposed to ambient temperature and humidity conditions for a time equivalent to the total sampling period. If the grab samples lose weight, the concurrent-drying procedure should be used. If the grab samples gain weight or show no change in weight the natural moisture procedure is used.

10.2 The calcination procedure does not necessitate the testing of the material for direction of weight change prior to its use.

CONCURRENT-DRYING PROCEDURE

11. Scope

11.1 The samples of undried material are pulverized and blended, and then dried concurrently in the same drier as samples of the undried material which have not been prepared. The loss on drying of the latter samples is used for the lot moisture value.

12. Procedure

12.1 Pulverize two of the secondary samples (Containers 2 and 4) in a disk-type pulverizer which is set to a plate gap of approximately 0.25 mm (0.01 in.).

12.2 Feed the samples into the pulverizer using a small vibrating feeder. Control the rate of flow to prevent overloading of the pulverizer and to minimize the heating of the material.

12.3 Transfer the pulverized material to a blender. Blend for 15 min, and remove a 100-g portion from the blender and manually screen-test. Pass 100 % of the sample through a screen with apertures of 0.177 mm (U.S. Sieve 80 mesh), and retain no more than 10 % of the sample on a screen with apertures of 0.149 mm (U.S. Sieve 100 mesh). If not, repeat the pulverization and blending processes.

12.4 Divide the blended material into two roughly equal portions and spread evenly in two stainless steel drying pans, approximately 152 by 305 by 51 mm (6 by 12 by 2 in.).

12.5 Transfer directly Containers 3 and 5, which are designated for the moisture determination, and spread in two tared

drying pans. Weigh the pans and samples, then place together with the pulverized and blender samples in adjacent positions in the same ovens to minimize temperature and atmosphere differences among the pans. All weighings must be carried out to ± 0.1 g.

12.6 Dry the samples at $110 \pm 2^\circ\text{C}$ ($230 \pm 4^\circ\text{F}$) until two successive weighings at 24-h intervals do not differ by more than 0.5 g for each pan or by more than 0, 1 % H_2O whichever is smaller. The moisture content assigned to the lot is the averaged weight percent loss of Samples 3 and 5.

12.7 Immediately after the drying period, remove the pulverized samples from the oven. As quickly as possible, place six approximately 150-g samples (or other agreed amount) in canning jars of appropriate capacity, and vacuum seal or wax seal the jars as described in Section 19.

13. Unground Samples

13.1 If testing for extractable organic is to be done, then an approximate 150-g portion of a blended, but unground sample is packaged as described in Section 19.

NATURAL MOISTURE PROCEDURE

14. Scope

14.1 In the natural-moisture procedure, the UOC samples are prepared and packaged without prior heating.

15. Procedure

15.1 Pulverize, blend, and screen-test the contents of secondary sample Containers 2 and 4 as described in the concurrent-drying procedure (see 12.1-12.3).

15.2 Package the material without delay as in 12.7.

16. Unground Samples

16.1 If testing for extractable organic is to be done, then an approximate 150-g portion of a blended, but unground sample is packaged as described in Section 19.

CALCINATION PROCEDURE

17. Scope

17.1 The calcination procedure involves calcining the sample to provide a material that can be returned to its calcined state by heating at 110°C (230°F) to remove moisture that may have been picked up during subsequent operations.

18. Procedure

18.1 Transfer two of the secondary samples (Containers 2 and 4) to tared heat-stable pans, and determine the gross weights without delay. Place these pans in the calcination furnace. Set aside Containers 3 and 5 for possible use in accordance with 18.4.

18.2 Calcine Samples 2 and 4 in a furnace for not less than 10 h at a temperature of $800 \pm 20^\circ\text{C}$ ($1470 \pm 68^\circ\text{F}$). As soon as possible after cooling, weigh the pans plus samples again to determine the loss in weight that is expressed as a percentage of the original sample weight.

18.3 If the difference between the weight loss of Samples 2 and 4 is 0.10 % absolute or less, determine the average percentage loss in weight and accept as final. Combine the two samples and prepare as the sample to be used for assay determination of uranium.

18.4 If the difference between the weight loss of Samples 2 and 4 is greater than 0.10 %, calcine Samples 3 and 5 under conditions of 18.2. If, in this case, the difference between the two weight losses is 0.10 % or less, follow the procedure described in 18.3 for Samples 3 and 5. If this difference is greater than 0.10 %, divide the primary sample again under the conditions of Section 7, 8, or 9 or the lot should be resampled.

18.5 Pulverize in a disk-type pulverizer which is set to a plate gap of approximately 0.25 mm (0.010 in.) the total contents of the pair of pans, on which determination of weight loss percentages have been made. Feed the samples into the pulverizer using a small vibrating feeder. Control the rate of flow to prevent overloading of the pulverizer.

18.6 Transfer the pulverized material to a blender. Blend for 15 min, and remove a 100-g portion from the blender and manually screen-test. Pass 100 % of the sample through a screen with apertures of 0.177 mm (U.S. Sieve 80 mesh), and retain no more than 10 % of the sample on a screen with apertures of 0.149 mm (U.S. Sieve 100 mesh). If not, repeat the pulverizing and blending processes.

18.7 Alternative processing methods to those described in 18.5 and 18.6 (for example, a ball mill) may be used provided the blended product conforms to the mesh size defined in 18.6.

18.8 After blending, place approximately six 150-g samples in canning jars of appropriate capacity, and vacuum seal or wax seal the jars.

18.9 Treat the two samples of Containers 1 and 6 as described in 18.5-18.8 to provide samples for the determination of impurities.

19. Sample Packaging

19.1 The prepared samples are packaged into glass jars of appropriate capacity (about 250 mL (0.5 pt)). These jars are constructed so that they can be sealed by applying a waterproof wax, or be vacuum sealed.

19.2 In order to minimize unaccounted gain or loss of moisture, the sample material and the container ideally should be at similar temperatures during packing.

20. Wax Sealing

20.1 The jars are constructed so that they can be effectively sealed by application of a low melting wax or equivalent. Tare weigh the jars and lids. Once the lid is placed on the filled jar, measure the weight and apply the sealant to the joint by conventional means. The implementation of this procedure should be restricted to calcined samples.

21. Vacuum Sealing

21.1 The jars are constructed such that they can be vacuum sealed. Tare weight the jars and lids. Prior to packaging, heat the jars only (not the lids), to 95°C (203°F) to ensure that they are dry and to prevent condensation of moisture. As soon as the samples are ready for packaging transfer to the heated jars.

21.2 Place the metal jar lids on the jars and heat with an electrical flat iron set to control at 82°C (180°F) for approximately 90 s to soften the sealing gasket material on the periphery of the lids.

21.3 Put the threaded ring on the jar to hold the lid in place. Do not tighten the ring at this point.

21.4 Place the jars in a vacuum apparatus and reduce the pressure to about 34 kPa (5 psi) (25 cm of mercury) in a period not to exceed 1.5 min.

21.5 Raise the pressure to atmospheric as quickly as possible to ensure a good air-tight seal, as indicated by a pronounced concave depression of the jar lid.

21.6 Tighten the jar rings and apply appropriate labels.

21.7 Place each jar into a plastic bag which is then heat sealed.

22. Sample Use

22.1 When samples are prepared by the natural-moisture or concurrent-drying procedures, all required portions for the determination of total uranium shall be immediately removed after the seal on the sample jar is broken, and weighed without prior drying. The remaining sample in the jars shall not be used for uranium analysis at a later date, even though the jars may have been partially resealed. These samples may be used for impurity analysis, except that the sample described in Section 13 or 16 is used for extractable-organic determination.

22.2 When the calcination procedure is used, the uranium and impurity analysis shall be performed on the relevant samples dried at 110°C (230°F) to constant weight.

23. Keywords

23.1 sampling; UOC; uranium ore; uranium-ore concentrate



APPENDIX

(Nonmandatory Information)

X1. AUGER SAMPLER RANDOM POSITIONS

TABLE X1.1 Random Positions

Note—The position of the auger sampler relative to a drum bang sampled may be designated as A, B, or C.
 Position A is near perimeter.
 Position B is midway to perimeter.
 Position C is center.

A	A	B	B	A	A	B	B	B	A
B	A	B	A	B	A	A	C	C	B
C	A	A	B	A	A	B	B	A	B
A	B	A	A	A	A	C	B	A	A
A	B	B	A	A	A	B	B	C	B
B	A	A	B	A	B	A	C	B	B
A	A	A	A	B	A	C	A	A	B
B	A	A	A	B	A	B	A	A	B
A	C	A	A	C	B	C	A	A	A
A	A	A	A	A	C	A	B	A	A
A	B	A	A	B	B	C	B	A	B

X1.1.1 The use of Table X1.1 will provide samples taken from Positions A, B, and C in the ratio of 5:3:1 which represents the relative volumes of the UOC at the sampling positions. One augering using either Position A, B, or C is used for each drum. The sequence is from left to right and is continued irrespective of lot changes.

The American Society for Testing and Materials takes no position respecting the validity of any patent rights asserted in connection with any item mentioned in this standard. Users of this standard are expressly advised that determination of the validity of any such patent rights, and the risk of infringement of such rights, are entirely their own responsibility.

This standard is subject to revision at any time by the responsible technical committee and must be reviewed every five years and if not revised, either reapproved or withdrawn. Your comments are invited either for revision of this standard or for additional standards and should be addressed to ASTM Headquarters. Your comments will receive careful consideration at a meeting of the responsible technical committee, which you may attend. If you feel that your comments have not received a fair hearing you should make your views known to the ASTM Committee on Standards, at the address shown below.

This standard is copyrighted by ASTM, 100 Barr Harbor Drive, PO Box C700, West Conshohocken, PA 19428-2959, United States. Individual reprints (single or multiple copies) of this standard may be obtained by contacting ASTM at the above address or at 610-832-9585 (phone), 610-832-9555 (fax), or service@astm.org (e-mail); or through the ASTM website (www.astm.org).