



# Standard Guide for Laboratory Evaluation of Automatic Pedestrian SNM Monitor Performance<sup>1</sup>

This standard is issued under the fixed designation C 1169; the number immediately following the designation indicates the year of original adoption or, in the case of revision, the year of last revision. A number in parentheses indicates the year of last reapproval. A superscript epsilon ( $\epsilon$ ) indicates an editorial change since the last revision or reapproval.

## 1. Scope

1.1 The requirement to search pedestrians for special nuclear material (SNM) to prevent its theft has long been a part of both United States Department of Energy and United States Nuclear Regulatory Commission rules for the physical protection of SNM. Information on the application of SNM monitors to perform such searches is provided in Guide C 1112. This guide establishes a means to compare the performance of different SNM pedestrian monitors operating in a specific laboratory environment.<sup>2</sup> The goal is to provide relative information on the capability of monitors to search pedestrians for small quantities of concealed SNM under characterized conditions. The outcome of testing assigns a sensitivity category to a monitor related to its SNM mass-detection probability; the monitor's corresponding nuisance-alarm probability for that sensitivity category is also determined and reported.

1.2 The evaluation uses a practical set of worst-case environmental, radiation emission, and radiation response factors so that a monitor's lowest level of performance in a practical operating environment for detecting small quantities of SNM is evaluated. As a result, when that monitor is moved from laboratory to routine operation, its performance will likely improve. This worst-case procedure leads to unclassified evaluation results that understate rather than overstate the performance of a properly used SNM monitor in operational use.

1.3 The evaluation applies to two types of SNM monitors that are used to detect small quantities of SNM. Both are automatic monitors; one monitors pedestrians as they walk through a portal formed by the monitor's radiation detectors (walkthrough or portal monitor), and the other monitors pedestrians who are stationary for a short period of time while they are monitored (wait-in monitor). The latter can be a portal monitor with a delay mechanism to halt a pedestrian for a few

seconds or it can be an access-control booth or room that contains radiation detectors to monitor a pedestrian waiting for clearance to pass.

1.4 The values stated in SI units are to be regarded as standard.

1.5 *This standard does not purport to address the safety concerns, if any, associated with its use. It is the responsibility of the user of this standard to establish appropriate safety and health practices and determine the applicability of regulatory limitations prior to use.*

## 2. Referenced Documents

### 2.1 ASTM Standards:

C 859 Terminology Relating to Nuclear Materials<sup>3</sup>

C 993 Guide for In-Plant Performance Evaluation of Automatic Pedestrian SNM Monitors<sup>3</sup>

C 1112 Guide for Application of Radiation Monitors to the Control and Physical Security of Special Nuclear Material<sup>3</sup>

C 1189 Guide to Procedures for Calibrating Automatic Pedestrian SNM Monitors<sup>3</sup>

## 3. Terminology

### 3.1 Definitions of Terms Specific to This Standard:

3.1.1 *confidence coefficient*—the theoretical proportion of confidence intervals from an infinite number of repetitions of an evaluation that would contain the true result.

3.1.1.1 *Discussion*—In a demonstration, if the true result were known the theoretical confidence coefficient would be the approximate proportion of confidence intervals, from a large number of repetitions of an evaluation, that contain the true result. Typical confidence coefficients are 0.90, 0.95 and 0.99.

3.1.2 *Confidence Interval for a Detection Probability*—An interval, based on an actual evaluation situation, so constructed that it contains the (true) detection probability with a stated confidence.

3.1.2.1 *Discussion*—Confidence is often expressed as 100\*the confidence coefficient. Thus, typical confidence levels are 90, 95 and 99 %.

<sup>1</sup> This guide is under the jurisdiction of ASTM Committee C26 on Nuclear Fuel Cycle and is the direct responsibility of Subcommittee C26.12 on Safeguard Applications.

Current edition approved June 10, 1997. Published May 1998. Originally approved in 1991. Last previous edition approved in 1997 as C 1169 – 97.

<sup>2</sup> Note that this is a laboratory evaluation and is not designed for routine in-plant use. A separate guide, C 993, is available for verifying routine in-plant performance.

<sup>3</sup> *Annual Book of ASTM Standards*, Vol 12.01.

3.1.3 *detection probability*—the proportion of passages for which the monitor is expected to alarm during passages of a particular test source.

3.1.3.1 *Discussion*—Although probabilities are properly expressed as proportions, performance requirements for detection probability in regulatory guidance have sometimes been expressed in percentage. In that case, the detection probability as a proportion can be obtained by dividing the percentage by 100.

3.1.4 *detection sensitivity category*—specified in terms of a test source mass for which the monitor has a 0.50 or greater detection probability, as measured by a test procedure having a 95 % confidence coefficient for its result. The specified 0.50 or greater detection probability is a very convenient one for testing. The limited number of test source masses used to define sensitivity categories (see Table 1 and Table 2) adequately describe the performance of SNM monitors that can detect small quantities of SNM.

3.1.5 *nuisance alarm*—a monitoring alarm not caused by SNM but by one of two other causes, which are statistical variation in the measurement process or natural background intensity variation. Other contributors to nuisance alarms, such as interfering radiation sources and equipment malfunction, should not be present during testing.

3.1.6 *radiation intensity*—expressed as the number of photons or neutrons emitted by a material per second or as the environmental background radiation dose rate.

3.1.7 *SNM (special nuclear material)*—plutonium of any isotopic composition, <sup>233</sup>U, or enriched uranium as defined in Terminology C 859. This term is used here to describe both SNM and strategic SNM, which is plutonium, uranium-233, and uranium enriched to 20 % or more in the <sup>235</sup>U isotope.

3.1.8 *SNM monitor*—a radiation detection system that measures ambient radiation intensity, determines an alarm threshold from the result, and then, when it monitors, sounds an alarm if its measured radiation intensity exceeds the threshold.

3.1.9 *standard SNM test source*—a metallic sphere or cube of SNM having maximum self attenuation of its emitted radiation and an isotopic composition to minimize that emission as described below. Encapsulation and filtering also affect radiation intensity, and particular details are listed for each source.

3.1.9.1 *standard plutonium source*—a metallic sphere or cube of low-burnup plutonium containing at least 93 % <sup>239</sup>Pu, less than 6.5 % <sup>240</sup>Pu, and less than 0.5 % impurities.

3.1.9.2 *Discussion*—A cadmium filter can reduce the impact of <sup>241</sup>Am, a plutonium decay product that will slowly build up in time and emit increasing amounts of 60-keV radiation.

TABLE 2 Mass Detection Sensitivities in Pedestrian Neutron Monitors<sup>A</sup>

Category	Description	Plutonium <sup>B</sup> (g)
NI	Standard Neutron	250
NIII	Improved Neutron	100
NIIII	High Sensitivity Neutron	30

<sup>A</sup>In a nominal 20 μR/h background intensity using standard metallic test sources and procedures described in 11.2.

<sup>B</sup>Low-burnup plutonium as described in 8.5. For monitors having gamma-ray sensitivity in addition to neutron sensitivity the plutonium must be shielded in 5-cm thick lead.

Begin use of 0.04-cm-thick cadmium filter when three or more years have elapsed since separation of plutonium decay products. If ten or more years have elapsed since separation, use a cadmium filter 0.08-cm thick. The protective encapsulation should be in as many layers as local rules require of a non-radioactive material such as aluminum (≤0.32-cm thick) or thin (≤0.16-cm thick) stainless steel or nickel to reduce unnecessary radiation absorption.

3.1.9.3 *standard uranium source*—a metallic sphere or cube of highly-enriched uranium (HEU) containing at least 93 % <sup>235</sup>U and less than 0.25 % impurities. Protective encapsulation should be thin plastic or thin aluminum (≤0.32-cm thick) to reduce unnecessary radiation absorption in the encapsulation. No additional filter is needed.

## 4. Summary of Guide

4.1 Evaluation follows a sequence of steps, each of which should reach an acceptable outcome before the next is begun. The steps are: placing the monitor into operation; determining nuisance alarm probability; determining detection probability; and categorizing the results.

4.2 The monitor is put into operation in a nominal 20 μR/h (5.2 nC/kg h or 1.43 pA/kg) background environment. The manufacturer's instructions are followed to assemble, calibrate (see Section 10), and begin using the monitor.

4.3 Nuisance alarm probability is determined (see Section 11) by automatic data collection with a system that cycles the monitor alternately through a group of simulated pedestrian passages and a background update while recording the background intensity and each of its alarms.

4.4 Detection probability is determined (see Section 12) by transporting SNM test sources through the monitor's least sensitive region, which is determined as part of the evaluation. Different individuals transport the SNM at their accustomed pace but in a specified manner. Results (number of detections and passages) are analyzed as a binomial experiment to give a confidence interval for the probability of detection that may place the monitor in a sensitivity category. If the monitor can be operated in different modes or at more than one spacing between its detectors, it should be evaluated in each mode and at each spacing that is expected to be used operationally.

4.5 The sensitivity category of a monitor is determined (see Section 13) by the smallest test source for which the monitor has a 0.50 or greater detection probability with 95 % confidence at an acceptable nuisance alarm probability.

TABLE 1 Mass Detection Sensitivities of SNM Monitors<sup>A</sup>

Category	Description	Uranium <sup>B</sup> (g)	Plutonium <sup>C</sup> (g)
I	Standard Plutonium	64	1
II	Standard Uranium	10	0.29
III	Improved Sensitivity	3	0.08
IV	High Sensitivity	1	0.03

<sup>A</sup>In a nominal 20 μR/h background intensity using standard metallic test sources and procedures described in 11.2.

<sup>B</sup>HEU as described in 8.4.

<sup>C</sup>Low-burnup plutonium as described in 8.5.

## 5. Significance and Use

5.1 SNM monitors are an effective and unobtrusive means to search pedestrians for concealed SNM. Nuclear facility security plans often include SNM monitors as one means to help prevent theft or unauthorized removal of designated quantities of SNM from access areas. This guide describes a way to evaluate and categorize the relative performance of available SNM monitors that might be considered for use in a security plan.

5.2 The significance of the evaluation for monitor users is that evaluated monitoring equipment has a verified capability. Unexpected deficiencies such as low sensitivity for highly self-absorbing forms of SNM, lower than expected sensitivity in areas having high natural background intensity, or a high nuisance-alarm probability from electronic noise or faulty alarm logic often can be detected during evaluation and corrected before a monitor is placed in operation or further marketed.

5.3 The significance of the evaluation for monitor manufacturers is that it may disclose deficiencies in design or construction that, when corrected, will improve the product. A monitor verified to be in a particular sensitivity category will be a product that customers who need that level of performance can purchase in good faith.

5.4 The established sensitivity categories for evaluated monitors will provide information to regulatory agencies on the performance range of monitoring equipment for detecting small quantities of SNM.

5.5 Independent monitor evaluation will encourage monitor manufacturers to provide appropriate documentation for calibrating and operating their monitors to obtain the best possible performance for detecting SNM.

5.6 The underlying assumptions in this guide are that SNM monitors are applied in a wide range of background environments at facilities that process a variety of chemical and physical forms of SNM. The operational experience with a monitor at one facility provides little comparative information for a user of SNM monitors at another facility where the environment and materials are different. A laboratory evaluation in a characterized environment using characterized test sources and providing information on both SNM detection probability and nuisance alarm probability does provide useful comparative information on different monitors.

5.7 The user of evaluation results is warned that the results are comparative ones for selection of monitoring equipment used to detect small quantities of SNM. Obtaining equivalent or better results for monitoring small quantities of SNM at any facility rests on properly installing the monitor at an appropriate location, maintaining monitor calibration, keeping the monitor in good repair with a testing and maintenance program, and providing proper training for operating personnel.

5.8 The evaluation uses essentially unshielded test sources; hence, results are based on detecting the entire gamma-ray or neutron spectrum of the sources. The effect of deliberate use of shielding materials on the performance of SNM monitors is beyond the scope of this guide.

## 6. Interferences

6.1 The evaluation requires a nominal natural background environment that has an intensity in the range of the highest found in the continental United States [nominal 20  $\mu\text{R/h}$  (5.2 nC/kg h or 1.43 pA/kg)] and has only natural variation. Locations having low backgrounds are not suitable for testing; other locations are unsuitable as well when variable backgrounds from other than natural causes are present. A simulated high intensity background produced by point sources is unsuitable.

6.2 Parts of the evaluation use specific values or measurements that can alter the testing outcome if not done properly. For example, an improperly measured background intensity (see 7.1) that is actually much higher or lower than stated in 6.1 will bias the results toward a lower or higher sensitivity category. Similarly, inattention to test source specification, method of carrying test sources through the monitor, and improper interpretation and reporting of results will bias the outcome. Other possible errors and biases in the evaluation results are discussed in Section 13.

## 7. Apparatus

7.1 Measuring the gamma-ray background intensity requires a precision ion chamber or similar environmental radiation measurement device that is calibrated to provide gamma-ray dose rate. For neutron monitors, the background intensity is inferred from the more readily measured gamma-ray intensity because the cosmic-ray and terrestrial factors that lead to high natural gamma-ray intensity are the same ones that produce high natural neutron background intensity.

7.2 The presence of unnatural sources of background during nuisance alarm testing can be discovered by recording the output of a background monitor or the output of the monitor's radiation detection circuits. A strip-chart recorder, data logger, and computer-generated display are convenient ways to record background data.

7.3 Alarms also must be recorded during nuisance alarm testing. For example, an event marker could record alarms on a background strip-chart record or a data logger, scaler, or computer could record alarms.

7.4 A scaler or other form of pulse counter may be necessary to average monitor signals to determine the monitor's least sensitive region. Net signals from a test source placed in different regions indicate the monitor's relative response there.

7.5 A timing device that provides a sequence of periodic or random (but not overlapping) occupancy signals and background update periods is needed for nuisance alarm determination. Appendix X1 gives one example of a timing circuit for the purpose.

7.6 Automatically cycling the monitor for nuisance alarm testing requires the monitor's alarm to automatically reset itself. If it does not, a means to generate an alarm reset signal is usually easy to provide. For example, the alarm signal can operate a solenoid that depresses the alarm reset pushbutton.

## 8. Test Materials

8.1 The materials required for this guide are recommended SNM test sources (see 3.1.9). These have minimum emitted

radiation intensity and are worst-case-performance sources. Any SNM of the same mass encountered in routine operation will have the same or a greater emitted radiation intensity and will be equally or more readily detected than the test sources.

8.2 The isotopic forms of SNM with minimum emission are HEU and low-burnup plutonium. These are the only types of SNM used for testing. The two materials have relatively low-energy gamma-ray spectra but the spectra are significantly different. Testing with HEU can usually establish a sensitivity category that is also valid for plutonium but the converse is not true. Most of the HEU spectrum is less energetic and more difficult to detect than the plutonium spectrum. The lower energy of the HEU gamma-ray spectrum results in more signal loss by attenuation in detector cabinet doors and by discrimination in the monitor's signal conditioning circuits. Hence, testing with plutonium alone does not provide adequate information on HEU sensitivity.

8.3 Testing with HEU and low-burnup plutonium demonstrates adequate sensitivity for equal amounts of the more radioactive forms of SNM that are also safeguarded. These are  $^{233}\text{U}$  and  $^{238}\text{Pu}$ .

8.4 Specifications for the HEU test sources<sup>4</sup> are that they be metallic HEU spheres (machining cost for this material is low) containing at least 93 % of the isotope  $^{235}\text{U}$ . The purity of the HEU should be at least 99.75 weight % uranium.

8.5 Specifications for the low-burnup plutonium test sources are that they be metallic spheres or assembled metallic fragments that resemble a sphere or cube held together with epoxy (machining costs for this material are high). The plutonium should contain at least 93.5 %  $^{239}\text{Pu}$  and no more than 6.5 %  $^{240}\text{Pu}$ , and the purity of the plutonium should be at least 99.5 weight % plutonium.

8.6 Test sources must be encapsulated to prevent contamination. Plastic suffices for HEU encapsulation, but a thin ( $\leq 0.16$ -cm thick) aluminum container can also be used.

8.7 Plutonium (or uranium) encapsulation should not unnecessarily reduce the intensity of emitted radiation above 60 keV. On the other hand, the 60-keV radiation intensity from plutonium should be reduced because its intensity increases in time as the  $^{241}\text{Am}$  daughter of  $^{241}\text{Pu}$  builds up. Plutonium test source material that was separated from its americium daughter products three or more years ago should have a surrounding cadmium absorber 0.04-cm thick as part of its encapsulation. The filter for material with more than ten years since separation should have a total cadmium thickness of 0.08 cm. As a source ages, its filter can be thickened by adding a layer to its encapsulation. Plutonium, being a more hazardous material, requires protective encapsulation in welded metallic containers that should be thin (0.05 to 0.16-cm thick) stainless steel or nickel to reduce unnecessary attenuation. Multiple encapsulation can use two containers as just described or two or more aluminum containers that can be thicker ( $\leq 0.32$ -cm thick).

<sup>4</sup> Both 10.7-g and 3-g HEU spheres are available to DOE contractors on loan or at cost to others from the Los Alamos National Laboratory, Group NIS-6, MS J-562, Los Alamos, NM 87545.

## 9. Test Monitors

9.1 Although an evaluation of a standard monitor is the goal, certain outputs and inputs that may not be standard are required for testing and are also recommended for production monitors.

9.2 If not already available at an external cable connector, the monitor's single-channel analyzer output or level-discriminator output should be buffered as needed for triggering a counter or oscilloscope and brought out to a BNC connector.

9.3 If not already available at an external cable connector, the monitor's amplifier analog output signal should be buffered as needed for external observation or processing and brought out to a BNC connector.

9.4 If not already available, the means to input a relay closure or other external occupancy signal should be provided on a terminal strip or connector.

9.5 Candidate monitors for specific sensitivity categories should have significantly more than the minimum capability for the category so that the monitor's performance can be readily verified.

## 10. Calibrating the Test Unit

10.1 The manufacturer's calibration procedure must be followed. If instructions are given for calibrating the monitor differently for plutonium or uranium, each of these can be used for separate evaluations, but a calibration that suffices for both materials is of most general interest and should be evaluated in any event. More information on calibration is available in Guide C 1189.

10.2 Once calibrated, the monitor should be operated as it would be in practice and any drift away from optimum calibration should be allowed to take place. If three months or another specified recalibration period has passed, or if a malfunction and repair has occurred, the complete evaluation should be restarted.

## 11. Procedure

### 11.1 *Procedure for Nuisance Alarm Testing:*

11.1.1 Nuisance alarm testing must be at least partially completed before sensitivity tests are begun. If the emerging result for nuisance alarm probability is too high, the cause must be determined and the monitor readjusted, modified, or repaired. After repair or readjustment, any previously obtained nuisance alarm and sensitivity results are not applicable. Published guidelines for acceptable nuisance alarm probability quote alarm rates that range from a low of 1 per 8 h operating shift **(1)**,<sup>5</sup> that is imprecise but, for example, would correspond to a nuisance alarm probability per passage of 0.00034 (1 nuisance alarm per 2880 passages) if a person passed through the monitor every 10 s, to a high rate of 1 per 1000 passages, that corresponds to a nuisance alarm probability per passage of 0.001 **(2)**.

11.1.2 Ideally, nuisance alarm testing would be sensitivity testing without carrying a test source. However, a monitor's

<sup>5</sup> The boldface numbers in parentheses refer to the list of references at the end of the text.

nuisance alarm probability for one monitoring comparison is usually very small (as small as 0.00003 for example) and 100 000 to 1 000 000 monitoring comparisons may be required for an adequately precise result. This amount of testing is easily obtained only with simulated passages. The absence of an occupant during a simulated passage does raise the nuisance alarm rate slightly because a pedestrian's body is not present to slightly lower the radiation intensity during monitoring (in one case by about 1.5 % in a 76 cm wide portal). However, this is in keeping with the general approach of worst-case testing to ensure that operational performance is better.

11.1.3 Nuisance alarm testing should take place only during periods of time when background is free of man-made variations. Records of background intensity during test periods should be checked for unexpected man-made variation.

11.1.4 For nuisance alarm testing, the monitor is automatically cycled through test periods comprised of 10 to 30 simulated passages followed by a full background update.

11.1.5 Alarms are recorded by an event marker or other means. After each alarm, the monitor must automatically reset itself so that testing can continue.

11.1.6 The elapsed time and total number of alarms during a testing period are obtained from alarm records.

11.1.7 Accumulated data can be used to obtain the latest result. The accumulated number of nuisance alarms divided by the number of monitoring passages determine the nuisance alarm probability. The number of passages may depend on whether the monitor is a walkthrough or wait-in one.

11.1.7.1 *Wait-In Monitors*— Wait-in monitors compare one or more monitoring measurements with an alarm threshold and then permit the occupant to depart. Hence, the number of passages should equal the number of simulated occupancies and can be calculated from the elapsed time and number of simulated occupancies per unit time.

11.1.7.2 *Walkthrough Monitors*—Walkthrough monitors usually continuously compare monitoring measurement results with an alarm threshold during the time they are occupied, that varies with passage speed. If the simulation duplicates the average occupancy time expected for normal use of the monitor, then the number of passages equals the number of simulated occupancies as in 11.1.7.1. However, if for some reason the simulated occupancy time is greater or less than the expected occupancy time for normal use, the number of passages has to be appropriately adjusted to compensate for the difference.

11.1.8 The result of this part of testing, the nuisance alarm probability per passage is the total number of alarms divided by the total number of passages. By the time 100 alarms have been observed, the relative standard deviation of alarm probability is about 10 % (the alarm probability is expected to be small, usually 0.001 or less) and the derived value is precise enough to make a final decision on whether the result is suitable to complete this part of testing.

#### 11.2 Procedure for Sensitivity Testing:

11.2.1 Once the monitor has been operating long enough to obtain an indication that nuisance alarm results will be acceptable, sensitivity tests can begin.

11.2.2 Determining the least sensitive region of the monitor can often be done by measuring the monitor's response to a large test source located in different regions of the monitor. The quantity to use for comparing regions is the net source response, that is the difference between a count with the test source in place and a background count with the source removed. The least sensitive region or regions should be visible as the relative minima in plots of the net source response. The plots can also disclose any shortcomings in measurement technique and precision. The number of measurements needed will depend on the number of detectors used in the monitor, where they are located, and the path followed by pedestrians being monitored.

11.2.2.1 *Walkthrough Portals With Large Detectors*— Monitors with large detectors at each side of a portal might be measured along a centerline from floor to ceiling. Choosing the least sensitive region when there is more than one low response region should take into account that the source may be in motion in one of them, for example when the source is attached to an arm or leg. More than one region may need to be fully evaluated to determine the least sensitive region.

11.2.2.2 *Walkthrough Portals With Many Small Detectors*— Portals having a large number of small detectors should be measured along the centerline from floor to ceiling and also along the portal sides between detectors. Choosing the least of nearly equal low response regions should take into account source motion when attached to an arm or leg. More than one region may need to be fully evaluated to determine the least sensitive region.

11.2.2.3 *Wait-In Portals*— In this case, the occupant is not in motion and any SNM is stationary during monitoring. In addition to measuring from floor to ceiling, measurements from front to back in appropriate horizontal planes are also needed to pick candidates for the least sensitive region. Body shielding is so important in this case that all low response regions may need to be fully evaluated to determine the least sensitive region.

11.2.3 Having located the least sensitivity region, a series of binomial experiments can begin. Pedestrians will pass through the monitor carrying the source but before they start, the total number of passages to be undertaken should be chosen. At least 40 passages should be made, and a suggested number of passages is 45.

11.2.4 Passages are performed by a group of pedestrians, preferably a group of both men and women, who individually transport a particular SNM source through the monitor in their individual, accustomed manner while carrying the source so that it is monitored in the least response region. However, in walkthrough monitors a word of caution is needed when attaching the test source to an arm or leg where its velocity could vary depending on the individual's pace. Variation can be reduced if a standard pace is adopted. For example, always using the pace shown in Fig. 1(a) is better than having individuals use a variable pace that ranges from planting the source in the portal as shown in Fig. 1(b) to swinging the source leg as rapidly as possible through the portal. Variation in passage speed is also of concern in walkthrough monitors where a nominal walking speed of 1.2 m/s is recommended.

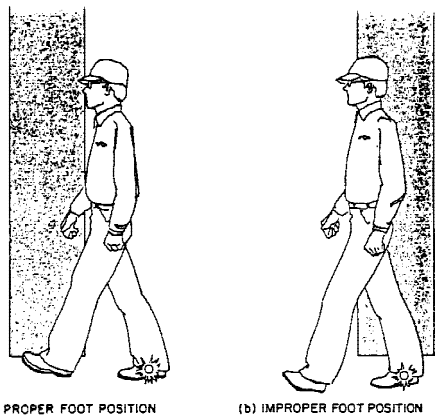

FIG. 1 Proper (a) and Improper (b) Foot Positioning for Testing a Walkthrough Monitor with a Source Attached to an Interior Ankle

11.2.5 A record of the number of passages and number of detections should be made as they take place. Each person from a group of at least four pedestrians should individually pass through the monitor repeatedly with the test source. Each person should make no more than five passages at a time before pausing to allow the monitor to obtain a new background. Each person should make no more than twelve passages total to lessen the chance of a bias caused by one individual. Each person should also repeatedly walk through the monitor in the same manner without carrying a source for the same number of passages to verify that unexpected items or conditions are not causing alarms.

11.2.6 The testing is in the form of a binomial experiment where an upper 95 % confidence interval for detection probability is to be determined. An upper 95 % confidence interval can be found using the 90 % confidence coefficient graphs of confidence intervals from Dixon and Massey (3) and ignoring the fact that true values of detection probability may fall above the interval's upper limit. Thus for example, after 20 passages with 0.70 detections, Fig. 2 shows a 90 % confidence interval of 0.48 to 0.87 for detection probability. The corresponding upper 95 % confidence interval for detection probability is 0.48 or greater and does not satisfy a test result requirement for a detection probability of 0.50 or greater with a 95 % confidence coefficient. Had 50 passages with 0.70 detections been made, the upper 95 % confidence interval for detection probability would be 0.57 or greater, that does satisfy a test result requirement for detection probability of 0.50 or greater with 95 % confidence.

11.2.7 Fig. 3 is a graph of the Dixon and Massey tables from Ref (2) with labels changed to proportions, showing a shaded acceptance region for the hypothesis that the detection probability has been determined to be 0.50 or greater with 95 % confidence as a function of the number of passages and the proportion detected. If the point representing the number of passages and the proportion of passages detected does not lie within the region or on its boundary, the hypothesis is rejected. For the number of passages suggested earlier, 45, the proportion of passages detected for acceptance must be 0.64 or greater.

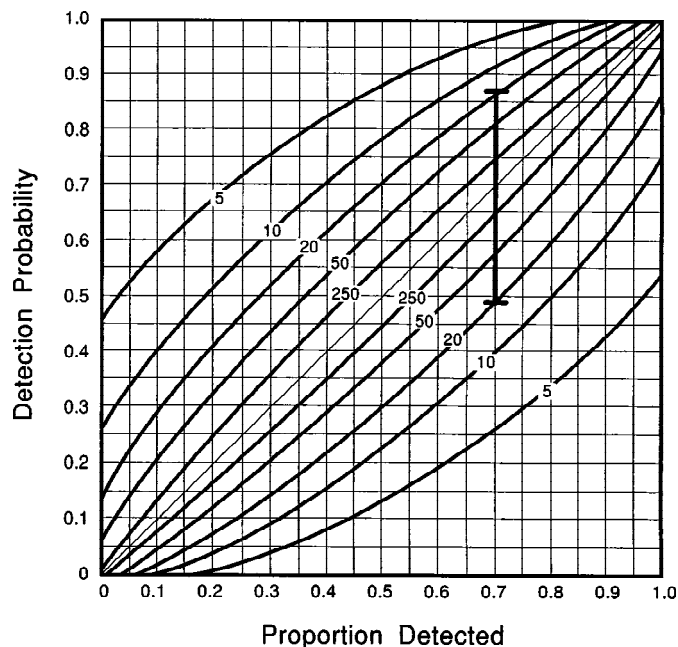

FIG. 2 Ninety Percent Confidence Intervals for Detection Probability

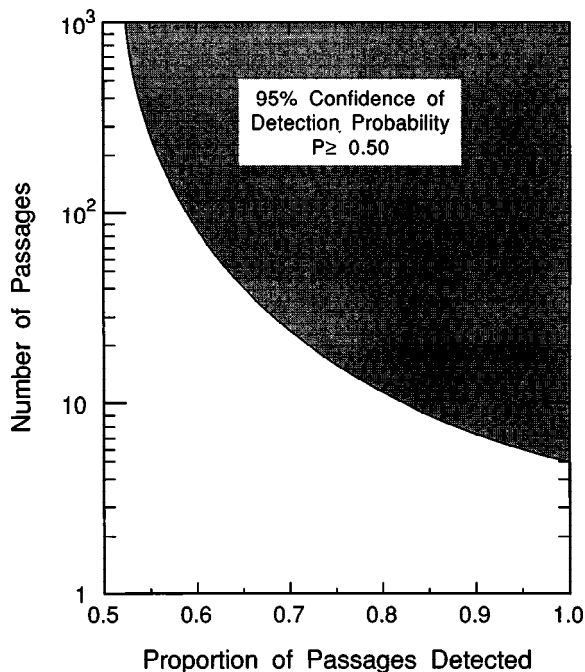

FIG. 3 Ninety-Five Percent Confidence Coefficient Test Result Region for Detection Probability 0.50 or Greater

## 12. Reporting Results

12.1 Sensitivity categories for walkthrough pedestrian monitors from Ref (4) are listed in Table 1 and apply to both walkthrough portal monitors and wait-in monitors.

12.2 Sensitivity categories for monitors that detect neutrons reflect the fact that neutron emission rates from SNM are lower than gamma-ray emission rates. Plutonium is the only type of SNM emitting significant numbers of neutrons and is the only test material. Sensitivity categories in Table 2 (4, 5) cover the

expected range of performance. Categories NI and NII correspond to gamma-ray SNM monitors using plastic scintillation detectors that also sense fast (unmoderated) neutrons from spontaneous fission in SNM. Category NIII corresponds to neutron-detection based SNM monitors that do not respond to gamma radiation and therefore have very low background count rates. These monitors use thermal neutron detectors and require that the fission neutrons first be moderated for detection.

12.3 The evaluation results are for a particular background intensity and place the monitor in one of the tabulated sensitivity categories at a particular nuisance alarm probability. Both the sensitivity category and the nuisance alarm probability must be reported because either one can be bettered at the expense of the other. In normal operation, however, both good sensitivity and a low nuisance alarm probability are usually needed, so one cannot be sacrificed. Separate categories might be necessary for uranium and plutonium performance.

12.4 Some important factors that influence the monitor's performance may unnecessarily be changed when monitors are put into routine operation. The evaluation report should include such information as the evaluated portal width, detector cabinet material, sensitivity switch settings, detector bias level (lower level discriminator setting), and all significant calibration parameters such as  $^{137}\text{Cs}$  662-keV gamma-ray pulse height in scintillation detectors or neutron pulse height in  $^3\text{He}$  proportional counters.

12.5 The evaluation report should also give a complete description of the evaluated monitor because manufacturers often supply monitors with different options that may affect performance. Appendix X2 gives an example of an evaluation report form that summarizes the most important information from an evaluation report.

### 13. Precision and Bias

13.1 The outcome of the evaluation is a mass detection sensitivity category achieved at a particular nuisance alarm probability. There is a possibility that a higher or lower category than deserved may be assigned. Should the true result be a detection probability that is less than 0.50, the monitor may be assigned to an undeserved category. The use of fairly broad sensitivity categories and the caution in 9.5 that evaluated monitors should have excess capability to make testing practical should make this a rare type of error.

13.2 Lower than expected performance during evaluation should not automatically terminate a monitor's evaluation with

a negative result. Manufacturers, testing organizations, and end users all have an interest in discovering and correcting flaws in design or manufacturing before SNM monitors begin operational use. Hence, when performance falls short and problems are found, they should be corrected and the complete evaluation restarted.

13.3 Biased sensitivity testing procedures can influence the evaluation results. In a walkthrough SNM monitor, passage speed affects performance. Care must be taken to avoid passage speeds that differ significantly from the group average specified in 11.2.4. Similarly, a walker's pacing can bias results if it differs from that described in 11.2.4 and illustrated in Fig. 1(a).

13.4 Seasonal footwear can bias the results of sensitivity testing when the test source is positioned inside a shoe. Winter footwear often is much heavier than summer footwear and provides greater shielding of source radiation.

13.5 Body mass may bias sensitivity testing results when only men or only women are used to transport test sources. A greater average weight for men could increase background attenuation and decrease a monitor's sensitivity. Hence, testing with all males might lead to lower sensitivity whereas testing with all females with a lower average weight might lead to higher sensitivity than would be obtained for a mixed group of testers.

13.6 Test source positions used for sensitivity testing may be important sources of bias. Sources attached to an arm or leg can move through a walkthrough monitor much more rapidly than other parts of the body and may be very difficult to detect. Sources attached at a belt buckle position may move slowly through the monitor's most sensitive region and be very easy to detect.

13.7 Test source shielding by the body may bias sensitivity testing results. Such positions as the inner thigh or armpit may provide shielding that depends on body weight and could bias results higher or lower than a population average depending on the individuals who participate in testing.

13.8 Inattention to the outlined test environment and test protocols can severely bias the testing outcomes. The background intensity should be nominally as stated in 6.1, nuisance alarm testing should be as extensive as stated in 11.1.8, test sources should be prepared as stated in Section 8, and test procedures in 11.2 should be followed. If not, the testing results have little value as comparative information for selecting SNM monitoring equipment.

APPENDIXES

(Nonmandatory Information)

X1. TIMING CIRCUIT FOR PRODUCING PERIODIC OCCUPANCY

X1.1 The circuit in Fig. X1.1 provides variable length occupied (nuisance alarm testing) and unoccupied (background update) periods by using a recycle timer and recycling time delay relay. During nuisance alarm testing, the recycle timer energizes the time delay relay to provide alternating timed periods of occupancy and vacancy.

X1.2 If the monitor does not accept a relay closure as an occupancy signal, the relay closure can be used to control

another device to cause occupancy. For example, the relay can operate a shutter to interrupt a light beam used as an occupancy sensor.

X1.3 When the circuit is used with a wait-in portal, the time intervals used in the two devices must be carefully chosen to avoid the possibility of causing an alarm by de-energizing the time delay relay and prematurely vacating the monitor.

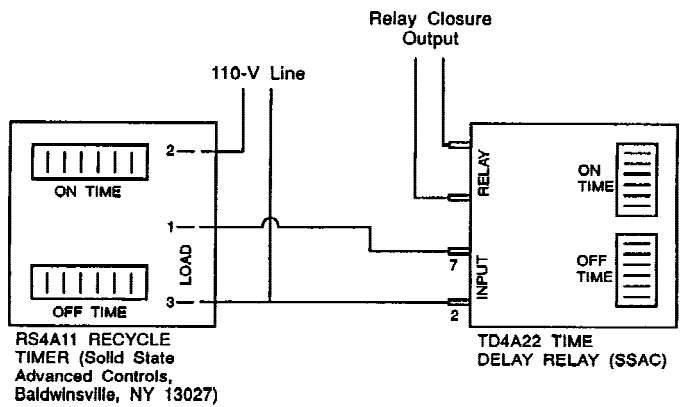

FIG. X1.1 A Circuit Providing Alternating Periods of Unoccupied Background Update and Cyclic Occupancy for Nuisance Alarm Testing



X2. LABORATORY EVALUATION SUMMARY REPORT FOR A PEDESTRIAN SNM MONITOR

X2.1 This example of a laboratory evaluation report form summarizes the results of an evaluation. It is not intended to be a substitute for a full written report.

Evaluated Monitor: Manufacturer \_\_\_\_\_ Model \_\_\_\_\_

Manufacturer's address and telephone \_\_\_\_\_

Special Modifications \_\_\_\_\_

Mode of Operation: Walkthrough \_\_\_\_\_ Wait-in \_\_\_\_\_

Type of detection logic \_\_\_\_\_

Mechanical Factors: (Attach manual or specification if possible)

Detector encapsulation: Material \_\_\_\_\_ Thickness \_\_\_\_\_

Cabinet doors Material \_\_\_\_\_ Thickness \_\_\_\_\_

Portal width (free passage) \_\_\_\_\_

Detector spacing (maximum) \_\_\_\_\_

Calibration Factors:

Pulse Heights: Gamma ray (<sup>137</sup>Cs) \_\_\_\_\_ Neutron (<sup>252</sup>Cf) \_\_\_\_\_

Detector Bias Level \_\_\_\_\_ Region of Interest \_\_\_\_\_

Selectable Sensitivity Options:

Count interval length \_\_\_\_\_

Number of background subintervals \_\_\_\_\_

Number of monitoring subintervals \_\_\_\_\_

N sigma \_\_\_\_\_

Sensitivity Switch Setting \_\_\_\_\_

Other \_\_\_\_\_

Test Environment Factors:

Background Intensity \_\_\_\_\_ μR/h

Instrument used \_\_\_\_\_

Describe method \_\_\_\_\_

Nuisance Alarm Results:

Nuisance alarms per passage \_\_\_\_\_ or passages per alarm \_\_\_\_\_

Data: Number of alarms \_\_\_\_\_ Number of passages \_\_\_\_\_

Method used \_\_\_\_\_

Describe any added circuits or modifications used to obtain data \_\_\_\_\_

Performance Test Protocol:

Describe test source \_\_\_\_\_

Describe how carried \_\_\_\_\_

Describe test procedure \_\_\_\_\_

Describe method of determining passage speed \_\_\_\_\_

Sensitivity Test Results:

HEU Category \_\_\_\_\_ Plutonium Category \_\_\_\_\_

Neutron Category \_\_\_\_\_

Notes:

## REFERENCES

- (1) "Personnel Doorway Monitor Standards," (January 1974), in *Entry-Control Systems Handbook*, Sandia National Laboratory Report SAND77-1033, Chapter 4, 1977.
- (2) Fehlau, P. E., Sampson, T. E., Henry, C. N., Bieri, J. M., and Chambers, W. H., "On-Site Inspection Procedures for SNM Doorway Monitors," U.S. NRC Contractor Report NUREG/CR-0598 and Los Alamos Scientific Laboratory Report LA-7646, 1979.
- (3) Dixon, W. J., and Massey, F. J., *Introduction to Statistical Analysis*, McGraw-Hill Book Co., New York, 1969.
- (4) Fehlau, P. E., "An Applications Guide to Pedestrian SNM Monitors," Los Alamos National Laboratory Report LA-10633-MS, February 1986.
- (5) Fehlau, P. E., "A Low-Cost Safeguards Pedestrian Portal Monitor Using Chamber Neutron Detectors," Proc. 9th Ann. ESARDA Symp. Safeguards Nuc. Mater. Manag., London, England, May 12 to 14, 1987 (ESARDA, 1987), European Safeguards Research and Development Association Report ESARDA 21, pp. 77–80.

*ASTM International takes no position respecting the validity of any patent rights asserted in connection with any item mentioned in this standard. Users of this standard are expressly advised that determination of the validity of any such patent rights, and the risk of infringement of such rights, are entirely their own responsibility.*

*This standard is subject to revision at any time by the responsible technical committee and must be reviewed every five years and if not revised, either reapproved or withdrawn. Your comments are invited either for revision of this standard or for additional standards and should be addressed to ASTM International Headquarters. Your comments will receive careful consideration at a meeting of the responsible technical committee, which you may attend. If you feel that your comments have not received a fair hearing you should make your views known to the ASTM Committee on Standards, at the address shown below.*

*This standard is copyrighted by ASTM International, 100 Barr Harbor Drive, PO Box C700, West Conshohocken, PA 19428-2959, United States. Individual reprints (single or multiple copies) of this standard may be obtained by contacting ASTM at the above address or at 610-832-9585 (phone), 610-832-9555 (fax), or [service@astm.org](mailto:service@astm.org) (e-mail); or through the ASTM website ([www.astm.org](http://www.astm.org)).*