



Designation: C 1316 – 9501

Standard Test Method for Nondestructive Assay of Nuclear Material in Scrap and Waste by Passive-Active Neutron Counting Using a ^{252}Cf Shuffler¹

This standard is issued under the fixed designation C 1316; the number immediately following the designation indicates the year of original adoption or, in the case of revision, the year of last revision. A number in parentheses indicates the year of last reapproval. A superscript epsilon (ϵ) indicates an editorial change since the last revision or reapproval.

1. Scope

1.1 This test method covers the nondestructive assay of scrap and waste for uranium and plutonium content using a ^{252}Cf shuffler. Shuffler measurements provide rapid results and can be applied to a variety of matrix materials in containers as large as 208-litre drums. Corrections are made for the effects of matrix material. This test method has been used to assay items containing uranium, plutonium, or both. Applications of this test method include measurements for safeguards, accountability, TRU, and U

¹ This test method is under the jurisdiction of ASTM Committee C-26 on Nuclear Fuel Cycle and is the direct responsibility of Subcommittee C26.10 on Nondestructive Assay.

Current edition approved Nov. 10, 1995; 2001. Published March 1996. September 2001. Originally published as C 1316 – 95. Last previous edition C 1316 – 95.

waste segregation, disposal, and process control purposes (1,2,3).²

1.1.1 This test method uses passive neutron coincidence counting to measure ²³⁸Pu, ²⁴⁰Pu, and ²⁴²Pu. It has been used to assay items with plutonium contents between 0.03 g and 1000 g. It could be used to measure other spontaneously fissioning isotopes. It specifically describes the approach used with shift register electronics; however, it can be adapted to other electronics.

1.1.2 This test method uses neutron irradiation with a moveable californium source and counting of the delayed neutrons from the induced fissions to measure ²³⁵U. It has been used to assay items with ²³⁵U contents between 0.1 g and 1000 g. It could be used to assay other fissionable isotopes.

1.2 This test method requires knowledge of the relative isotopic composition to determine the mass of the different elements.

1.3 This test method may give biased results for measurements of containers that include large quantities of hydrogen.

1.4 The techniques described in this test method have been applied to materials other than scrap and waste. These other applications are not addressed in this test method.

1.5 *This standard does not purport to address all of the safety concerns, if any, associated with its use. It is the responsibility of the user of this standard to establish appropriate safety and health practices and determine the applicability of regulatory limitations prior to use.* Specific precautionary statements are given in Section 8.

2. Referenced Documents

2.1 ASTM Standards:

C 859 Terminology Relating to Nuclear Materials³

C 986 Guide for Developing Training Programs in the Nuclear Fuel Cycle³

C 1009 Guide for Establishing a Quality Assurance Program for Analytical Chemistry Laboratories Within the Nuclear Industry³

C 1030 Test Method for Determination of Plutonium Isotopic Composition by Gamma-Ray Spectrometry³

C 1068 Guide for Qualification of Measurement Methods by a Laboratory Within the Nuclear Industry³

C 1128 Guide for Preparation of Working Reference Materials for Use in the Analysis of Nuclear Fuel Cycle Materials³

C 1133 Test Method for Nondestructive Assay of Special Nuclear Material in Low Density Scrap and Waste by Segmented Passive Gamma-Ray Scanning³

C 1156 Guide for Establishing Calibration for a Measurement Method Used to Analyze Nuclear Fuel Cycle Materials³

C 1207 Test Method for Nondestructive Assay of Plutonium in Scrap and Waste by Passive Neutron Coincidence Counting³

C 1210 Guide for Establishing a Measurement System Quality Control Program for Analytical Chemistry Laboratories Within the Nuclear Industry³

C 1215 Guide for Preparing and Interpreting Precision and Bias Statements in Test Method Standards used in the Nuclear Industry³

2.2 ANSI Documents:

ANSI 15.20 Guide to Calibrating Nondestructive Assay Systems⁴

ANSI N15.36 Nondestructive Assay Measurement Control and Assurance

~~ANSI/IEEE 739—Software Quality Assurance Plans⁴~~

~~ANSI/IEEE 828—Software Configuration Management Plans⁴~~

~~ANSI/IEEE 1042—Guide to Software Configuration Management⁴~~

~~ANSI/IEEE 1063—Standard for Software User Documentation⁴~~

3. Terminology

3.1 *Definitions*—Terms shall be defined in accordance with Terminology C 859.

3.2 *Definitions of Terms Specific to This Standard:*

3.2.1 *accidentals (a), n*—the number of neutrons detected in the (a) gate interval following the initial detection of each neutron during the selected count time, *t*. These neutrons come from many sources and are not physically correlated with the initial neutron.

3.2.2 *active mode, n*—determines total fissile mass in the assayed item through neutron interrogation and counting of the delayed neutrons from induced fissions.

3.2.3 *benign matrix, n*—a matrix that has negligible effects on the neutron transport. A benign matrix includes very little neutron moderator or neutron absorber.

3.2.4 *coincidence gate length, n*—the time interval following the detection of a neutron during which additional neutrons are considered to be in coincidence with the original neutron.

3.2.5 *coincident neutrons, n*—neutrons emitted simultaneously from a single event. Two or more coincident neutrons are correlated in time with the occurrence of one event, such as fissioning of a nucleus.

3.2.6 *die-away time, n*—the average lifetime of a neutron from the time of emission until the neutron is detected. The average lifetime is the time required for the neutron population to drop to 1/e of the original value. Die-away time is a function of several

² The boldface numbers in parentheses refer to a list of references at the end of this test method.

³ *Annual Book of ASTM Standards*, Vol 12.01.

⁴ Available from American National Standards Institute, 11 W. 42nd St., 13th Floor, New York, NY 10036.

parameters including the detector design, the assay item characteristics, and the neutron energies.

3.2.7 *effective ²⁴⁰Pu mass (m_{eff})*, n —the mass of ²⁴⁰Pu that would produce the same coincidence response in the instrument as the assay item. It is a function of the quantities of the even-mass isotopes of plutonium and fundamental nuclear constants. It is specific to the type of coincidence circuitry used (4).

3.2.8 *flux monitors*, n —detectors in the measurement chamber that measure the interrogating neutron flux.

3.2.9 *item*, n —the entire scrap or waste container being measured and its contents.

3.2.10 *lump*, n —that contiguous mass of nuclear material that is sufficient to affect the measured signal.

3.2.11 *lumps*, n —in the context of the active measurement mode, have a dimension larger than the mean free path of an interrogating neutron and consequently exhibit self-shielding.

3.2.12 *lumps*, n —in the context of the passive measurement mode, have a dimension larger than the mean free path of a fission neutron and consequently exhibit multiplication.

3.2.13 *matrix*, n —the material that comprises the bulk of the item, except for the special nuclear material and the container. This is the material in which the special nuclear material is embedded.

3.2.14 *matrix-specific calibration*, n —uses a calibration matrix similar to the waste matrix to be measured. No matrix correction factors are used; this calibration is generally not appropriate for other matrices.

3.2.15 *neutron absorbers*, n —materials that have relatively large absorption cross sections for thermal neutrons. Absorbers with the largest cross sections are commonly known as neutron poisons. Some examples are lithium, boron, cadmium, and gadolinium.

3.2.16 *neutron coincidence counting*, n —a technique used to measure the rate of coincident neutron emission in the measured item. Fig. 1 shows the probability of detecting a neutron as a function of time.

3.2.17 *neutron moderators*, n —those materials that slow fast neutrons through elastic scattering. Materials containing hydrogen are the primary example.

3.2.18 *neutron multiplication*, n —the fractional increase in the number of second-generation neutrons emitted, following spontaneous fission, due to self-induced fissions in the item being measured.

3.2.19 *passive mode*, n —determines the total spontaneously fissioning mass in the measured item through the detection of coincidence neutrons. The coincident neutrons are prompt neutrons.

3.2.20 *predelay*, n —the time interval immediately after the detection of the initiating neutron. This time is selected to allow the electronics to recover and detect subsequent neutrons.

3.2.21 *prompt and delayed neutrons*, n —neutrons occurring as a result of fissions. Approximately 99 % are prompt neutrons, emitted directly from fission within 10^{-13} s after fission begins. The remainder are delayed neutrons, the result of neutron decay by some of the fission products. Delayed neutrons appear seconds or minutes after the fission begins.

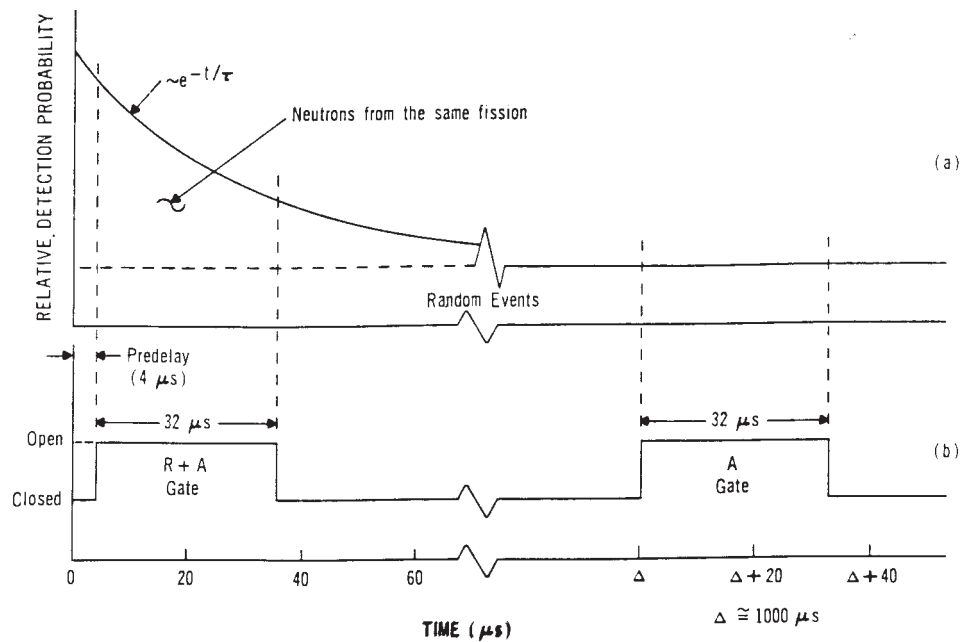

a) Simplified relative neutron detection probability distribution.

b) Coincidence gate timing diagram.

NOTE 1—Curve (a) is a simplified probability distribution showing the decay, as a function of time, for detecting a second neutron from a fission event. The probability for detecting an uncorrelated neutron is constant with time. Typical coincidence timing parameters are shown in (b).

FIG. 1 Probability of Neutron Detection as a Function of Time

3.2.22 (α, n) reactions, n —occur when energetic alpha particles collide with low atomic number nuclei, such as O, F, or Mg, producing single neutrons. Neutrons produced in this manner are not correlated in time and are a source of “singles” in passive neutron counting and a source of background in active neutron counting.

3.2.23 reals (r), n —the number of real coincident neutrons in the $(r + a)$ gate interval following the initial detection of each neutron during the selected count time, t . This quantity is derived from the two measured quantities, $r + a$ and a .

3.2.24 reals plus accidentals ($r + a$), n —the number of neutrons detected in the $(r + a)$ gate interval following the initial detection of each neutron during the selected count time, t . These events are due to neutrons that are coincident with the initial neutron (reals) and to neutrons that are not correlated with the initial neutron (accidental coincidences). This is a measured quantity.

3.2.25 shift-register-based coincidence circuit, n —an electronic circuit for determining totals ($[\tau]$), reals plus accidentals ($r + a$), and accidentals (a) in a selected count time (t). Fig. 1 illustrates the time relationship between the measured quantities.

3.2.26 shuffler technique, n —an active-neutron nondestructive assay technique that moves a ^{252}Cf source close to the assay item to irradiate the fissile material, then counts delayed neutrons from the induced fissions after the source is withdrawn. Fig. 2 illustrates the measurement concept, and the two source positions that the source “shuffles” between.

3.2.27 totals ($[\tau]$), n —the total number of individual neutrons detected during the selected count time, t . This is a measured quantity.

3.2.28 transuranic waste (TRU waste), n —defined by the United States Department of Energy as any waste containing alpha-emitting isotopes with atomic number greater than 92 and half-life greater than 20 years, with α activity concentrations greater than 100 nCi per gram of bulk waste.

3.3 volume weighted average response, n —an estimate of the count rate that would be obtained from a drum containing a uniform distribution of special nuclear material. It is a weighted average calculated from a series of measurements as follows:

3.3.1 The drum is divided into 15 or so volume elements,

3.3.2 A point source is centered in one of the volume elements and measured,

3.3.3 The point source is moved to the next volume element and measured, and

3.3.4 Each response is weighted by the size of the corresponding element. (See Appendix X1 for a more detailed explanation.)

4. Summary of Test Method

4.1 This test method consists of two distinct modes of operation: passive and active. The instrument that performs the active mode measurement is referred to as a “shuffler” due to the motion of the ^{252}Cf source. This test method usually relies on passive neutron coincidence counting to determine the plutonium content of the item, and active neutron irradiation followed by delayed neutron counting to determine the uranium content.

4.1.1 *Passive Neutron Coincidence Counting Mode*—The even mass isotopes of plutonium fission spontaneously. Approximately two prompt neutrons are emitted per fission. The number of these coincident neutrons detected by the instrument is correlated to the quantity of even mass isotopes of plutonium. The total plutonium mass is determined from the known isotopic ratios and the measured quantity of even mass isotopes. This test method refers specifically to the shift register coincidence counting electronics (see Ref 4 and Test Method C 1207).

4.1.2 *Active Neutron (Shuffler) Mode*—Fissions in ^{235}U can be induced by bombarding uranium with neutrons. Approximately 1 % of the neutrons per fission are delayed, being emitted from the fission products for several minutes after the fission event. The active mode consists of several irradiate-count cycles, or shuffles, of the ^{252}Cf source between the positions illustrated in Fig. 2. Californium-252 emits a fission neutron spectrum. During each shuffle, a ^{252}Cf source is moved close to the item for a short irradiation, then moved to a shielded position while the delayed neutrons are counted. The number of these delayed neutrons detected by the instrument is correlated with the quantity of ^{235}U . The total uranium mass is determined from the known isotopic ratios and the measured quantity of ^{235}U .

4.2 Either corrections are made for the effects of neutron absorbers and moderators in the matrix, or a matrix-specific calibration is used. The effect that needs correction is the increase or decrease in the neutron signal caused by the matrix.

4.3 Corrections are made for electronic deadtime, neutron background, and the ^{252}Cf source decay.

4.4 The active mode also induces fissions in plutonium if it is present in the assay item. The passive measurement of plutonium can be used to correct the active measurement of ^{235}U for the presence of plutonium.

4.5 Calibrations are based on measurements of well documented reference materials. The method includes measurement control tests to verify reliable and stable performance of the instrument.

5. Significance and Use

5.1 This test method is used to determine the uranium and plutonium content of scrap and waste in containers. Measurement count times have been 100 to 1000 s. The following limits may be further restricted depending upon specific matrix, calibration material, criticality safety, or counting equipment considerations.

5.1.1 The passive measurement has been applied to benign matrices in 208-litre drums with plutonium content ranging from 30 mg to 1 kg.

5.1.2 The active measurement has been applied to benign matrices in 208-litre drums with ^{235}U content ranging from 100 mg to 1 kg.

5.2 This test method can be used to demonstrate compliance with the radioactivity levels specified in safeguards, waste,

^{252}Cf . SHUFFLER MEASUREMENT PRINCIPLE

A ^{252}Cf . NEUTRON SOURCE IS USED TO INDUCE FISSIONS IN THE SAMPLE.

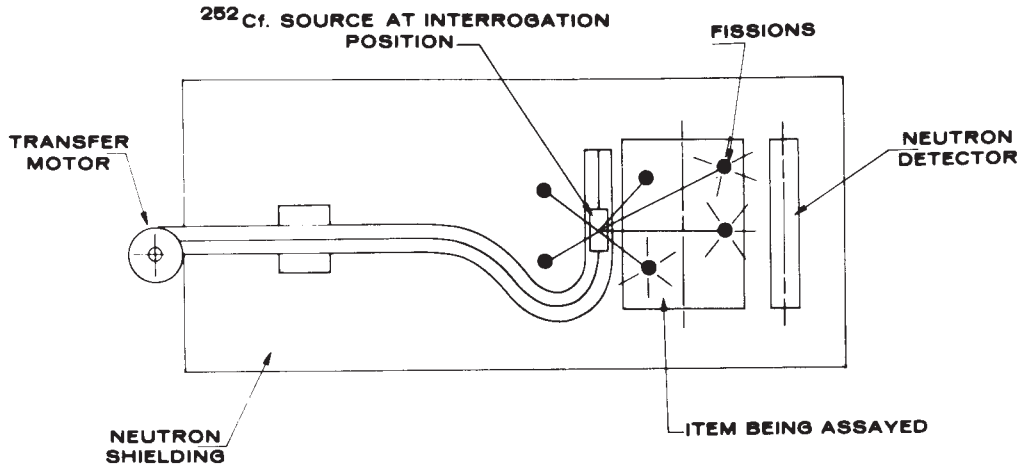

DELAYED NEUTRONS ARE COUNTED WITH THE SOURCE STORED

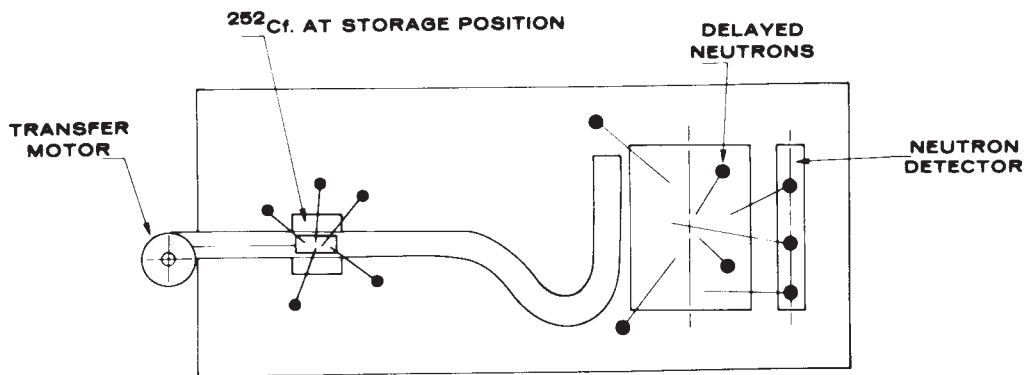

NOTE 1—The two main features of the active technique are shown. The shuffler measurement consists of several cycles. Each cycle includes an irradiation of the item by the ^{252}Cf source for about 10 s, followed by a counting period of about 10 s while the source is stored in a shield.

FIG. 2 ^{252}Cf Shuffler Measurement Principle

disposal, and environmental regulations. (See NRC regulatory guides 5.11, 5.53, DOE Order 5820.2a, and 10CFR61 sections 61.55 and sections 61.56, 40CFR191, and DOE/WIPP-069.)

5.3 This test method can detect diversion attempts that use bulk neutron shielding to encapsulate nuclear material.

5.4 The bias of the measurement results is related to the item size and density, the homogeneity and composition of the matrix, and the quantity and distribution of the nuclear material. The precision of the measurement results is related to the quantity of nuclear material and the count time of the measurement.

5.4.1 For both the matrix-specific and the matrix-correction approaches, the method assumes the calibration materials match the items to be measured with respect to the homogeneity and composition of the matrix, the neutron moderator and absorber content, and the quantity of nuclear material, to the extent they affect the measurement.

5.4.2 It is recommended that measurements be made on small containers of scrap and waste before they are combined in large containers.

5.4.3 It is recommended that measurements be made on containers with homogeneous contents. In general, heterogeneity in the distribution of nuclear material, neutron moderators, and neutron absorbers has the potential to cause biased results.

5.5 This test method assumes that the isotopic compositions of the contributing elements are known.

5.6 This test method assumes that the distribution of the contributing isotopes is uniform throughout the container when the matrix affects neutron transport.

5.7 This test method assumes that large quantities of special nuclear material are not concentrated in a small portion of the container.

5.8 Reliable and consistent results from the application of this test method require training of personnel who package the scrap and waste prior to measurement. (See ANSI 15.20, Guide C 1009, Guide C 986, and Guide C 1068 for training guidance.)

6. Interferences

6.1 Potential sources of measurement interference include unexpected nuclear material contributing to the active or passive neutron signal, self-shielding by large lumps of fissile material, neutron multiplication, excessive quantities of absorbers or moderators in the matrix, heterogeneity of the matrix, and the heterogeneity of the nuclear material distribution within a moderating matrix. In general, the greatest potential source of bias for active neutron measurement is heterogeneity of the nuclear material within a highly moderating matrix, while the greatest for passive neutron measurement is neutron moderation and absorption (5).

6.2 The techniques described in this test method cannot distinguish which isotope is generating the measured response. If more than one nuclide that produces a response is present, the relative abundances and relative responses of those nuclides must be known.

6.2.1 *Active Mode*— The presence of other fissionable nuclides will increase the delayed neutron count rate, causing an overestimation of the ^{235}U content unless a correction is made. For example, a calibration based on highly enriched uranium will cause biased results if the unknowns contain low-enriched uranium or plutonium.

6.2.2 *Passive Mode*— The presence of other spontaneous fission nuclides, such as curium, will increase the coincident neutron rates, causing an overestimation of plutonium content unless a correction is made. The active mode measurement of plutonium is not sensitive to this source of bias.

6.3 Lumps of nuclear material can exhibit self-shielding or multiplication. This effect is larger for moderating matrices (hydrogen).

6.3.1 *Active Mode (Self-Shielding)*—The nuclear material on the surface of the lump shields the inside of the lump from the interrogating neutrons.

6.3.2 *Passive Mode (Multiplication)*—Neutrons originating in the lump induce fissions in the same lump.

6.4 Moderators in the matrix can cause a bias in the measurement results, unless a correction is made. The magnitude and direction of this bias depend on the quantity of moderator present, the distribution of the fissile material, and the size of the item (2).

6.4.1 Although moderation is the greatest potential source of bias for passive measurements, the passive method is generally less susceptible to the presence of moderator than the active method.

6.4.2 The presence of absorbers in the matrix can cause bias if there is sufficient moderator present.

6.4.3 The instrument produces a nonuniform response for large containers with large quantities of hydrogen in the matrix. In these cases, a source at the center of the container can produce either a higher or lower response than the same source located at the surface of the container.

6.5 Background neutron count rates from cosmic ray-induced spallation can degrade the measurement sensitivity and the measurement precision. High-background count rates mask the instrument response to small quantities of special nuclear material for both the active and passive modes.

7. Apparatus

7.1 The apparatus used in this test method can be obtained commercially. Specific applications may require customized designs. The following description is one possible design. Fig. 3 is a cutaway illustration of a shuffler to measure 208-litre drums. In this design, the ^{252}Cf source storage shield is positioned on top of the measurement chamber. This design weighs approximately 8000 kg, and is 3 m high and 2 m in diameter.

7.2 *Counting Assembly*—see Fig. 4.

7.2.1 The neutron detectors are ^3He proportional counters embedded in polyethylene, located around the item in a near 4π geometry. The detection efficiency for neutrons of fission energy should be at least 15 %. Larger detection efficiencies provide better precision and lower detection limits for a given count time. The counter detection efficiency should vary less than 10 % over the item volume with no item present.

HIGH DENSITY WASTE SHUFFLER

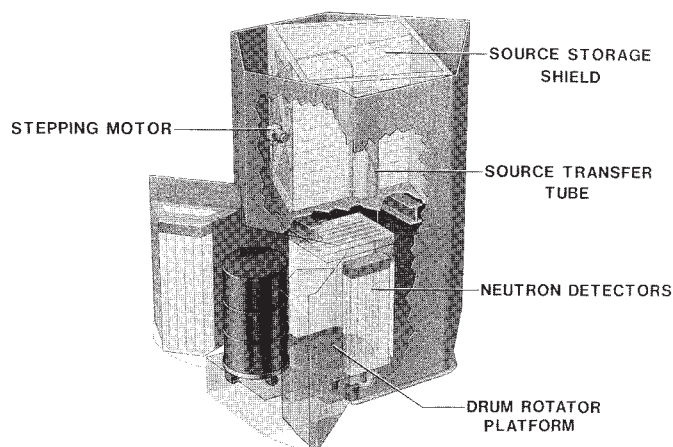

Los Alamos

NOTE 1—A sketch of a shuffler designed to assay 208-litre drums. The source storage shield is a 2000-kg, 1.2-metre cube that resides close to the measurement chamber. In this design it is on top of the measurement chamber. The stepping motor pushes the ^{252}Cf source through the source transfer tube between the storage position and the irradiation position inside the measurement chamber.

FIG. 3 Shuffler for 208-litre Drums of Waste

7.2.2 The flux monitors are ^3He proportional counters mounted on the inner walls of the measurement chamber and not embedded in polyethylene. One flux monitor is covered with cadmium 1 mm thick; the other is bare. The cadmium shields one flux monitor from thermal neutrons; therefore, the two flux monitors can be compared in order to provide information about the neutron energy distribution.

7.3 *Shielding*—The quantity of radiation shielding for the ^{252}Cf source is determined by personnel safety requirements rather than by background considerations.

7.3.1 The measurement chamber is surrounded by one or two feet of materials such as polyethylene and boron to shield the operator during the ^{252}Cf irradiation.

7.3.2 The shield for the ^{252}Cf storage position is typically 0.6 m thick (1.2-m cube), or the source is placed 1.8 m underground. Composite shields are more effective than polyethylene for large ^{252}Cf sources (6).

7.4 *Electronics*— High count rate, commercially available nuclear electronics provide standard logic pulses from the ^3He proportional counters. These pulses are typically processed by shift register coincidence electronics for the passive measurement, and by fast scalers for the active measurement. Other coincidence counting electronics can be used, with appropriate changes to the data reduction equations.

7.5 *Californium-252 Source Drive System*—The source is attached to a flexible drive cable that runs inside a guide tube. The source movement is controlled by stepping motors or an alternative that offers precise timing, positioning, and computer control. During the active measurement, variations in the timing of the irradiation or counting portions of the shuffles cause variations in the measured response. Modern components easily reduce this problem to negligible levels.

7.6 Californium-252 sources are commercially available and are usually replaced every five years. The vendor should understand the safety issues and provide guidance in addressing them.

7.6.1 The vendor should encapsulate the ^{252}Cf , attach the source drive cable, provide shielded shipping casks, and assist with the source installation and disposal.

7.6.2 The vendor should provide documentation for the ruggedness and integrity of the source encapsulation and perform swipes to demonstrate that the outside of the source capsule is not contaminated.

7.7 Data acquisition and reduction, control of the source motion, and the diagnostic tests require interfacing the instrument to a computer as shown in Fig. 5. The computer and software normally are provided by the vendor.

7.8 *Customized Design Issues:*

7.8.1 An initial ^{252}Cf source size of 550 μg is generally adequate for measurements of 208-litre drums.

7.8.2 It is recommended that the size of the measurement chamber be just slightly larger than the size of the items to be measured. If small items require measurement in a large measurement chamber, the items should be centered in the chamber.

7.8.3 During an active measurement of a large item, the item should be rotated and the californium source should scan the vertical length of the item.

7.8.4 The standard shuffler configuration assumes some hydrogenous and some metallic matrices will be measured. The

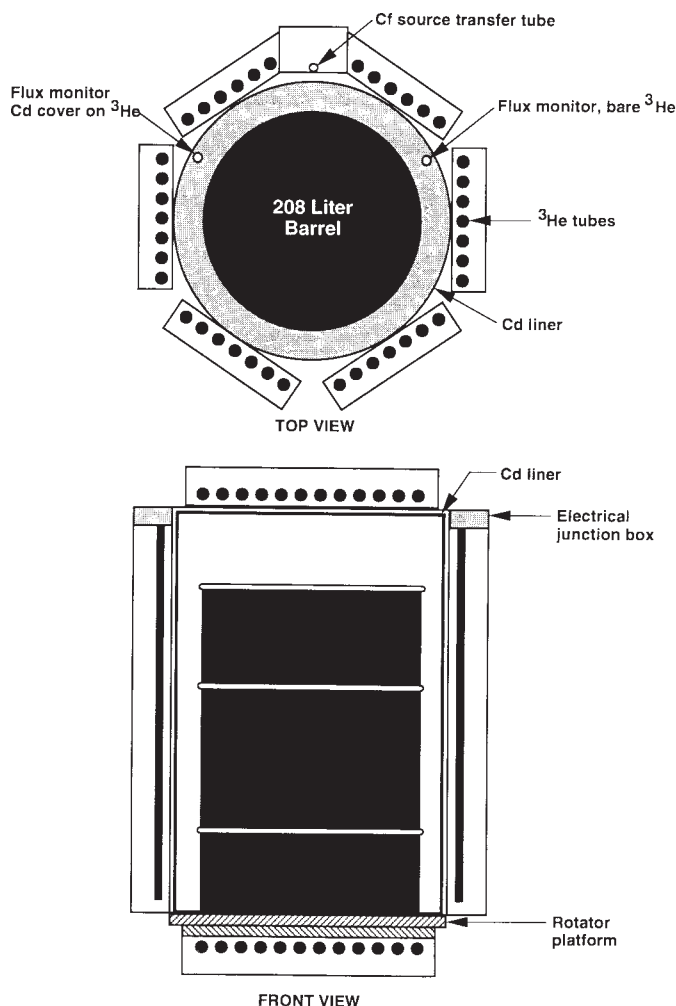

SHUFFLER DETECTOR BANK DIAGRAM

NOTE 1—The front and top views of the measurement chamber shown in Fig. 1 are shown here in detail. The 208-litre barrel rotates on a platform above the bottom detector bank. Six side banks surround the drum, with the ^{252}Cf source transfer tube at the rear of the item. The two flux monitors are placed at the rear of the item chamber.

FIG. 4 Shuffler Detector Bank Diagram

interrogation-neutron energies are kept high by not using spectrum tailoring materials between the californium source and the item being measured and using a steel reflector behind the californium source (1,2). This configuration includes lining the assay chamber with cadmium, which prevents neutrons that are thermalized in the polyethylene of the detector banks from entering the measurement chamber.

7.8.4.1 When it is assured that (a) lumps are not a significant problem and (b) the matrix is a weak moderator, a polyethylene sleeve can be placed around the assay item for the active mode measurement to reduce the energies of the interrogating neutrons, enhancing the fission rate, the precision, and the sensitivity. A different calibration is necessary for “sleeve” measurements.

8. Hazards

8.1 *Safety Hazards*— Consult qualified professionals as needed.

8.1.1 Take precautions to maintain personnel radiation exposures as low as possible. Typical doses at the surface of the instrument are 20 $\mu\text{Sv/hr}$ (2 mRem/hr) or less.

8.1.1.1 The radiation dose from 550 μg ^{252}Cf (unshielded) is about 10 mSv/hr (1 Rem/hr) at 1 m, consisting of both gamma and neutron radiation. Large ^{252}Cf sources require remote handling, shielding, and interlocks on automatic transfer mechanisms to help prevent excessive exposure.

8.1.1.2 For large source shields, the gamma rays resulting from neutron capture in hydrogen can contribute significantly to the dose on the outside of the shield; shields loaded with boron greatly reduce this effect.

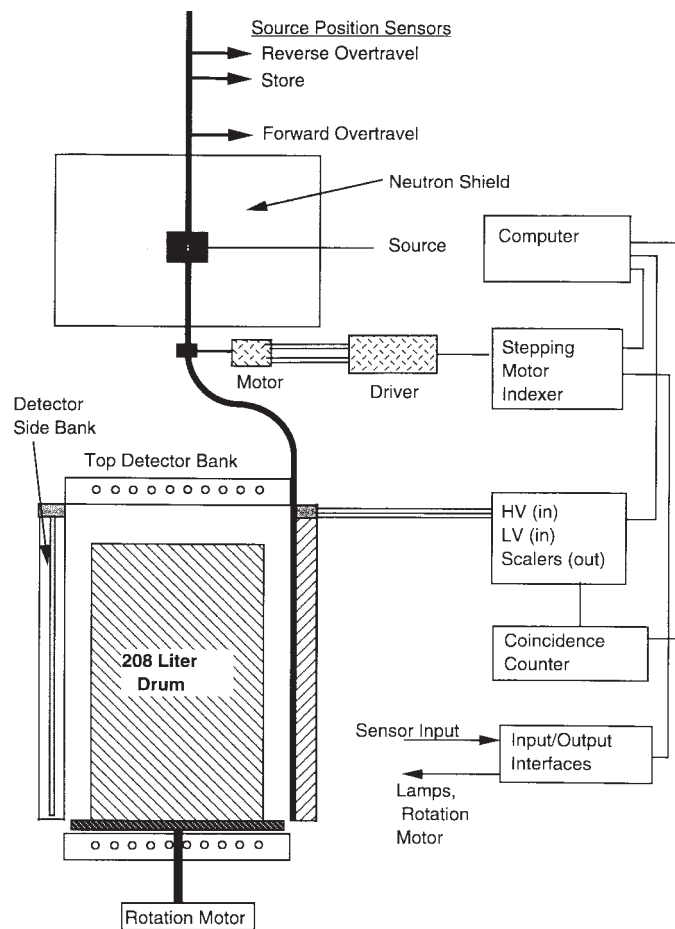

Shuffler Electronic Controls Diagram

NOTE 1—The electrical components and their connections are indicated. The ^{252}Cf source is moved by the stepping motor and driver. Three source sensors are used to verify the source position. The detector signals are amplified and discriminated in junction boxes into which the detectors are fastened. The logic outputs of the discriminators are fed to scalers and a coincidence counting module. The computer controls the source and rotator and receives the results from the scalers and coincidence counter.

FIG. 5 Shuffler Electronic Controls Diagram

8.1.2 Take precautions to prevent inhalation, ingestion, or the spread of radioactive contamination. Periodic alpha monitoring of calibration materials, measurement control items, and scrap and waste containers to verify their integrity is recommended.

8.1.3 Take precautions regarding nuclear criticality, especially of unknown items. The measurement chamber approximates a reflecting geometry for fast neutrons. Do not assume that waste is not of criticality concern.

8.1.4 Take precautions to prevent inhalation, ingestion, or the spread of cadmium and lead, if used as shielding. They should be covered with nontoxic materials.

8.1.5 Take precautions to avoid contact with high voltage. The proportional counters require low current supplies of approximately 2000 V.

8.2 *Technical Hazards*—The results of this test method might be used to make decisions regarding disposal of items or cessation of safeguards on the items. Consult qualified professionals and Guide C 986 as needed.

NOTE 1—**Caution:** A measurement result that is based on an inappropriate material category, that is reached with inappropriate calibration materials, or that is outside the range of calibration might be biased.

9. Initial Preparation of Apparatus

9.1 The initial preparation of the shuffler passive/active neutron apparatus is outlined in 9.2 through 9.6, which discuss the initial setup, calibration, and the initialization of measurement control. The details of preparation are site-specific, dependent on the material categories to be measured, and generally performed by experts.

9.2 Initial Setup:

9.2.1 The apparatus weight exceeds typical industrial floor load capacities. Check for adequate floor load capacity before installation.

9.2.2 Locate the apparatus to minimize radiation exposure to the operator from scrap and waste items. The shuffler's shielding screens the measurement chamber from most sources of background.

9.2.3 Perform the initial setup recommended by the system manufacturer, obtaining assistance as needed.

9.2.3.1 Most electronics settings are optimized by the manufacturer, and changing them may affect the instrument's performance.

9.2.3.2 The initial setup might include verifying or testing the following items: (1) that all software is loaded and running; (2) the safety features for the Cf source drive mechanism; (3) the operation of the source drive mechanism; (4) the status lamps; (5) the deadtime coefficients and the coincidence gate length; (6) the rotation motor; (7) the Cf source transfer velocity, acceleration, and scanning parameters; (8) the parallel port inputs and outputs; and (9) testing the neutron detection electronics with background and with small sources.

9.3 *Calibration: Preparation*—Use this test method with a scrap and waste management plan that segregates materials with respect to their neutron moderation and absorption properties. Refs **2 and 7** describe calibration exercises and provide illustrative data. Additional sources of information are Guides C 1009, C 1068, C 1128, C 1156, C 1210, and C 1215; ANSI Guide 15.20; NRC Guides 5.11 and 5.53; DOE Order ~~5820.2a~~, **435.1**; and U.S. Regulations 10CFR61 and 40CFR141.

9.3.1 Determine the different material types that represent the scrap or waste streams to be measured.

9.3.2 Prepare and characterize the calibration materials. They should represent the material types with respect to parameters that affect the measurement, such as moderation and absorption. The calibration materials should span the special nuclear material mass ranges expected in the scrap or waste to be measured. The fabrication should document traceability for the special nuclear material parameters. Appendix X1 summarizes one possible approach, the volume weighted average **(2,8)**.

9.3.3 The user of this test method should record the calibration procedure and data. The data should demonstrate the variation of the instrument response as a function of the nuclear material mass and the matrix.

9.4 *Calibration: Response vs. Mass*—This calibration determines the relationship between the measured instrument response and the mass of nuclear material. If the matrix-specific calibration approach is being used, this calibration data is obtained using the specific matrix found in the unknowns **(7)**. Otherwise, a benign matrix is used. The flux monitor data may be recorded for later use in assessing whether the correct matrix-specific calibration is being used. If the polyethylene sleeve is used for measurements of a certain material category, the calibration data is acquired with it also **(2,7,9)**.

9.4.1 *active mode*—relates the delayed neutron count rate to the ²³⁵U mass.

9.4.2 *passive mode*—relates the coincident neutron count rate to the effective mass of ²⁴⁰Pu.

9.4.3 Determine the range of the calibration. This is often defined by the smallest and largest masses used in the calibration.

9.4.3.1 The best fit to the calibration function within the calibration range sometimes yields nonsensical results outside of the calibration range. Any use of the instrument outside of the calibration range should be evaluated carefully.

9.4.3.2 If the calibration is extended to very small masses, the range should begin at zero instead of the lowest mass used in the calibration. The user should evaluate the response of the instrument with matrix items that contain no special nuclear material.

9.4.4 Measure each calibration mass such that the measurement precision is better than that expected for assay items of similar mass by using longer count times or replicate counts.

9.4.4.1 Measurements of small mass items can have large uncertainties due to lack of signal. If the measurement precision is 10 % or worse, such measurements might be more useful to check the calibration rather than determine it.

9.4.5 Analyze the calibration data to determine an appropriate function. The choice of calibration function will depend on the characteristics of the material categories and the calibration mass range **(1,2,6,7,10-17)**.

9.4.5.1 Calibration data for waste measurements with small amounts of special nuclear material can generally be fitted with a linear function.

9.4.5.2 If the calibration is extended to very small masses, the calibration might produce less bias if the fit is forced through the origin. The user should verify the appropriateness of this with measurements of matrix material without special nuclear material present.

9.4.5.3 Calibration data for scrap measurements of high mass items may not be suitable for fitting with a linear function.

9.5 *Determining the Matrix Correction*—This section is not applicable if the matrix-specific calibration is being used. This section describes a procedure that determines the relationship between the measured flux monitor response and the neutron moderation and absorption effects of the matrix on the measured count rate. This relationship will determine a correction to the count rate data that is made before the calibration described in 9.4 is used. Different corrections are required for the active and passive modes. Appendix X1 summarizes one approach, the volume weighted average **(2)**.

9.5.1 Determine the range of matrix correction for the active and passive modes separately.

9.5.1.1 At some point, the moderator and absorber content will be sufficiently large as to shield the innermost locations in the sample. The user should not try to make a correction for this measurement situation, where special nuclear material could be in the sample but not respond.

9.5.1.2 The user must choose how large a response variation with position is acceptable. A hydrogen density of 0.03 g/cm³ will yield a maximum-to-minimum response variation of approximately 2.4 for 208-litre drums **(2)**. Sometimes a variation this large

is acceptable for waste measurements but not for scrap measurements.

9.5.2 Measure the flux monitor responses and the count rates from the source for each matrix. The measurement precisions should be smaller than those typically obtained in measurements of unknowns or small enough to make a negligible contribution to the overall measurement error.

9.5.3 Demonstrate that the flux monitor response is independent of the special nuclear material source size and location in the item. For waste measurements, it is generally sufficient to show that the effects of special nuclear material location are smaller than the corrected effects of changing the matrix.

9.5.4 Analyze the data to determine a suitable flux monitor correction function. The choice of correction function will depend on the characteristics of the material categories. Several functions have been used to perform an empirical fit to this type of data (2,5,6,12). Obtain expert assistance if necessary.

9.5.4.1 The corrected data in Fig. 6 and Fig. 7 for homogenous distributions of ²³⁵U, shown only as an example, used the following empirical function (2):

$$CF = 1/R^{p(R)}, \text{ where the exponent } p(R) = a1 R^2 + a2 R + a3 \tag{1}$$

where:

CF = correction factor,

R = bare to cadmium-covered flux monitor response ratio,

$a1$ = fitted coefficient for the quadratic term,

$a2$ = fitted coefficient for the linear term, and

$a3$ = fitted coefficient for the intercept.

Appendix X1 describes how this data was collected.

9.5.4.2 We will use the subscript a to indicate the active mode correction factor, CF_a , and the subscript p to indicate the passive mode correction factor, CF_p , in Section 11.

9.5.4.3 The fitted coefficients for the corrected active mode data shown in Fig. 6 are: $a1 = 0.0$; $a2 = -0.654757$; and $a3 = 4.03148$.

9.5.4.4 The fitted coefficients for the corrected passive mode data shown in Fig. 7 are: $a1 = -1.5298$; $a2 = -0.43812$; and $a3 = 18.9911$.

9.5.5 An alternative approach is the matrix-specific calibration, where the user attempts to match the matrix effects of the unknown items with the calibration items (7). This approach might use the flux monitor data to verify that the calibration and item matrices are suitably matched.

9.6 *Initialize Measurement Control*—The need for adjustment of the instrument can be determined by measurement control procedures (18) (ANSI N15.36). These procedures make use of background measurements, replicate measurements of a specific item, and periodic remeasurement of certain items.

9.6.1 Determine the measurement control item responses and their uncertainties. These values are the ones to which future measurements will be compared (see 10.1).

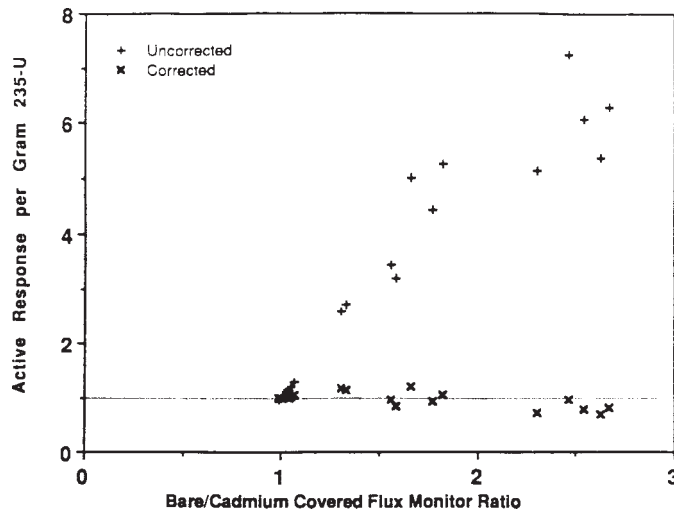

NOTE 1—The measured active response per gram of ²³⁵U in 208-litre drums is shown for 20 matrices. Both the uncorrected response (+) and the flux monitor corrected response (x) are plotted. The standard deviation of the corrected responses is 14 %. The matrices have a wide range of characteristics typically found in facilities (2). The largest hydrogen content in a matrix was 9.65 kg; the largest boron content was 0.20 kg.

FIG. 6 Active Response as a Function of Flux Monitor Ratio

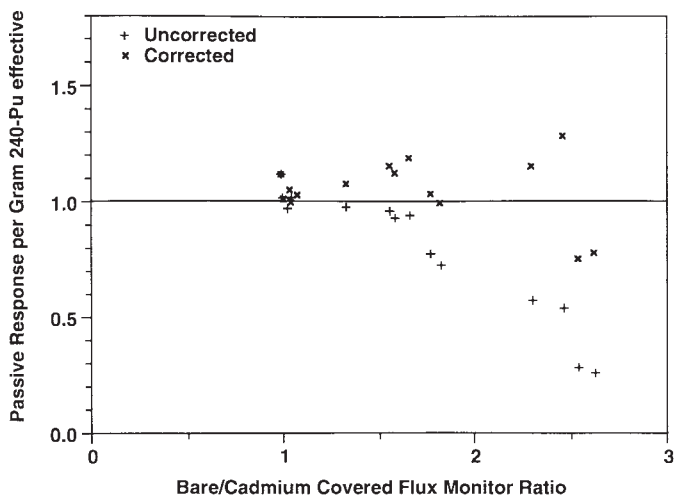

NOTE 1—The measured passive response per gram of ²⁴⁰Pu effective is shown for 18 matrices. Both the uncorrected response (+) and the flux monitor corrected response (x) are plotted. The standard deviation of the corrected responses is 12 %. The matrices have a wide range of characteristics typically found in facilities (2). The largest hydrogen content in a matrix was 9.65 kg; the largest boron content was 0.20 kg.

FIG. 7 Passive Response as a Function of Flux Monitor Ratio

9.6.2 Items used in measurement control must provide consistent measured values within statistical expectations each time they are measured. Perform corrections for half-life decay when necessary.

9.6.3 Documentation of the measurement control of the instrument is required (DOE Order-5633.3b)-474.1).

9.6.4 The choice of control limits and the action required after a “ failure” should take into consideration the measurement uncertainties and the probability of a false positive (18).

10. Procedure

10.1 After calibration, the procedure consists of measurements of items with unknown uranium or plutonium content and measurements that demonstrate that the apparatus is calibrated and functioning properly (measurement control).

10.2 *Measurement Control*—Measurement control measurements are made before assays of unknowns and are interspersed between measurements of unknowns to verify proper functioning of the instrument. If the measurement control indicates the instrument response has changed, determine the cause of the change and perform the necessary repairs. In addition, all measurements of unknowns since the last successful test are suspect and may need to be repeated.

10.2.1 *Background Measurements*—Perform periodic background measurements (18).

10.2.1.1 *Passive Mode*— Traditional practice is to perform these measurements daily with no special nuclear material in the assay chamber. Low total neutron count rates verify that no breakdown of the proportional counters or their electronics has occurred. Count rates of zero suggest the detector high voltage is off, part of the detection electronics is nonfunctional, or the detector electronics are disconnected. This background measurement is generally used in the calculations.

10.2.1.2 *Active Mode*— A background measurement is made at the start of each assay while the item is in the assay chamber, before the source shuffles begin.

10.2.2 *Measurement Control Bias Measurement*—Perform periodic measurements of stable items containing special nuclear material to verify the stability of the instrument response (18). Typically high and low masses are used on different days. Traditional practice is to perform a daily measurement for instruments used daily. For instruments used intermittently, this check is recommended before and after each use. Agreement with the previous value within the control limits indicates long-term stability of the instrument’s response. Long-term stability suggests that the calibration is still valid. Low results may indicate that a detector or detector bank is not functioning correctly. High results may indicate electrical noise.

10.2.2.1 The measurement control item used for the check must provide a consistent response. Corrections should be made for radioactive decay.

10.2.2.2 The uncertainty estimated from counting statistics for these measurements will be constant for a given count time, except for changes due to source decay. Otherwise, the source of variation should be investigated.

10.2.3 *Measurement Control Precision Measurement*—Perform periodic replicate counts of different items to verify the estimates of the measurement precision (18). This test might be conducted monthly or after each calibration. Statistical agreement between the standard deviation of the replicates and the uncertainty estimate from a single measurement’s counting statistics indicates short-term stability of the instrument’s response. Lack of agreement might indicate background variations, electrical instabilities, or errors in the implementation of the software algorithms.

10.3 Item Measurements:

10.3.1 Position the item to be measured in the counting chamber. The counting geometry should be the same for all measurements. If the polyethylene sleeve was used in the calibration, use it for assay of the item.

10.3.2 Measure for the chosen count times. It is often advisable to measure unknowns and measurement control items for the same count times.

10.3.2.1 *Passive Mode*— The passive count time is typically between 400 and 1000 s. When a matrix correction is desired, the passive count is followed by a short count (on the order of 10 s) with the ^{252}Cf source interrogating the item.

10.3.2.2 *Active Mode*— The item is rotated during the active measurement, asynchronously with the ^{252}Cf source motion. The active count (for a 1000-s assay) generally consists of a 250-s background count of the item with the source stored, followed by approximately 30 shuffles of the ^{252}Cf source, each with a 10-s interrogation and a 10-s delayed neutron count time.

10.3.3 When the counts are complete, record the measured quantities (by use of computer).

10.3.3.1 *Passive Mode*:

τ	= total neutrons counted,
$r + a$	= reals plus accidentals counted,
a	= accidentals counted, and
t	= total counting time.

If the matrix correction is desired, from the active mode,

r_1	= the cadmium-covered flux monitor count rate, and
r_2	= the bare flux monitor count rate.

10.3.3.2 *Active Mode*:

T_1	= the number of delayed neutrons in all shuffles,
t_1	= the delayed neutron counting time in all shuffles,
$bkgd$	= the background counts,
t_2	= the background counting time,
r_1	= the cadmium-covered flux monitor count rate, and
r_2	= the bare flux monitor count rate.

10.3.4 These diagnostic tests are recommended for each measurement.

10.3.4.1 *Passive Mode*— (a) The total neutron count rate can be used to estimate the accidentals rate in the “accidentals/totals” test (**4,15**). Lack of agreement within statistical uncertainties between the estimated and measured accidentals count rates suggests a hardware failure in the coincidence circuitry or that the background neutron count rate changed significantly during the measurement; (b) Each measurement can be divided into several short counting periods, and statistical tests performed looking for outliers in the individual counting periods (**5,10,15,19,20**). This “outlier” test reduces the effects of cosmic ray background or of changing conditions during the measurement. Outliers are generally replaced with data from an additional counting period, which is obtained without operator intervention by the software.

10.3.4.2 *Active Mode*— (a) A detector bank with zero counts is suspect and reported with an error message (**1,2**). This error condition might indicate the detector bank is not functional. If backgrounds are very low in every detector bank, this diagnostic might be more confusing than helpful; (b) Ratios of counts in different detector banks can be compared with historical values; if a ratio is statistically out of bounds, an error message can be generated (**1,2**). This error condition might indicate that either a detector bank is not functioning correctly or the assay item is not suitable for measurement. For low count rates, the value of this diagnostic is also low; (c) The overall regularity of the various phases of an assay can be checked by calculating a quantity (**1,2**) from the measured times for motion of the ^{252}Cf source and the count times. This quantity is compared to the value calculated using the nominal times for motion and counting. The two values normally differ by less than 0.5 %, otherwise an error message is generated. This error condition indicates a hardware failure in the source motion controller or the clock.

10.3.4.3 *Active Mode*— The neutron transmission through the item has been used to evaluate whether the item behaves similarly to the calibration items (**7**). During an irradiation with the ^{252}Cf source, compare the measured count rate in the door detector banks with the rate obtained with the calibration items. A statistically significant difference suggests that the wrong calibration is being used. A very low value suggests that inadequate penetration of the item has occurred, the measurement is not sensitive to the center of the item, and the potential exists for undetected nuclear material to be in the center of the item. It is possible to use the flux monitor count rates in a similar manner (**2**).

10.3.5 Calculate the amount of uranium or plutonium in the item (by use of the computer).

10.3.6 If replicate measurements are performed, wait four minutes after the ^{252}Cf irradiation ends before starting the next assay.

10.3.7 Remove the item from the counting chamber.

11. Calculations

11.1 This section provides a summary of the calculations developed for a 208-litre system. Use of other electronics may require different equations. The calculations are usually performed by the software, not by the user. The vendor should provide quality assurance that the calculations are correctly implemented in the software. The calculations follow the same general approach whether the results are used for calibration, measurement control, or determining an unknown. Estimates of the measurement uncertainties follow standard propagation techniques and are detailed in the references.

11.2 *Passive Assay for Plutonium*—Data reduction for the passive coincidence measurement is also explained in Test Method

C 1207 and Refs **2, 4, 15,** and **20**. Most of the variables were defined in 10.2.3.

11.2.1 Determine the total neutron count rate, T , rate,

$$T = \tau/t \quad (2)$$

11.2.2 Determine the coincidence count rate, R , and its random statistical uncertainty, $\sigma(R)$. The approximation for $\sigma(R)$ given below is adequate for most applications (see Refs **4** and **15,** and Test Method C 1207).

$$R = [(r + a) - a]/t \quad (3)$$

$$\sigma(R) = 1.2 [(r + a) + a]^{0.5}/t \quad (4)$$

11.2.3 Correct both total and coincidence neutron count rates for electronic deadtime (**4**). For example,

$$T' = T \exp(\delta T/4) \quad (5)$$

and

$$R' = R \exp(\delta T) \quad (6)$$

where:

$$\delta = a + b \times T$$

and the parameters a and b are supplied by the manufacturer. These parameters depend on the number and type of detector preamplifier electronics. Nominal values for a large apparatus are (**6**):

$$a = 0.44 \times 10^{-6} \text{ s} \quad (7)$$

$$b = 0.14 \times 10^{-13} \text{ (s)}^2 \quad (8)$$

A similar deadtime correction is made for the flux monitor data if they are used.

11.2.4 Perform a background subtraction.

$$T'' = T' - T'_b \quad (9)$$

$$R'' = R' - R'_b \quad (10)$$

where:

T'_b and R'_b are the corrected rates determined with no special nuclear material in the sample chamber.

11.2.5 *Matrix Correction:*

11.2.5.1 If the matrix correction calibration is being used, make a correction for matrix effects using the flux monitor responses (**1,2,5,10**) obtained during the ^{252}Cf interrogation.

$$R_c = R'' \times CF_p(\text{flux monitor}) \quad (11)$$

$$R_c = R'' \times CF_p(\text{flux monitor}) \quad (11)$$

where:

the passive flux monitor correction, CF_p (flux-monitor), is discussed in 9.4 and Ref (**2**);

11.2.5.2 If the matrix-specific calibration approach is being used, no matrix correction is made.

11.2.6 As the assay gets larger, effects that have the potential to cause bias, like multiplication, become more important, if not corrected (**4,15,16,20**).

11.2.7 Use the calibration function, the parameters described in 9.3, and R_c to calculate the assay result in terms of the effective ^{240}Pu mass, m_{eff} . The effective plutonium mass is defined in terms of the masses, m_A , of the plutonium isotopes, A , as:

$$m_{\text{eff}} = 2.52 m_{238} + m_{240} + 1.68 m_{242} \quad (12)$$

11.2.7.1 Waste measurement data are generally suitable for a linear function through the origin:

$$R_c = k1 \times m_{\text{eff}} \quad (13)$$

$$R_c = k1 m_{\text{eff}} \times m_{\text{eff}} \quad (13)$$

where:

$k1$ is the calibration constant determined in 9.3.

11.2.7.2 Scrap measurement data might require a quadratic function (**15,16,20**):

$$R_c = k0 + k1 m_{\text{eff}} + k2 (m_{\text{eff}})^2 \quad (14)$$

where:

$k0$, $k1$, and $k2$ are the calibration constants determined in 9.3.

11.2.7.3 Other methods of data analysis are available that take advantage of additional information when it is available (4,15,16,20).

11.2.8 Use the isotopic ratios and m_{eff} to calculate the assay result in terms of total plutonium:

$$\text{mass } P_u = m_{eff}(2.52 f_{238} + f_{240} + 1.68 f_{242}) \quad (15)$$

where:

f_A = the weight fractions of plutonium isotope A.

11.2.9 The estimate of the measurement uncertainty should include the components that cause significant effects. These generally include counting statistics, calibration errors, uncertainties in the matrix correction factor, and uncertainties in the isotopic ratios. Some components may be difficult to quantify.

11.3 *Active Assay for Uranium*—Data reduction for the active shuffler measurement is explained in Refs 1 and 2. Most of the variables were defined in 10.2.3.

11.3.1 The uncorrected delayed neutron count rate, ucr , is computed from the total counts and time.

$$ucr = T1/t1 \quad (16)$$

where:

$T1$ = neutron counts for n shuffles, and

$t1$ = total counting time for n shuffles.

It is assumed that the same number of shuffles and the same time pattern are used for unknowns and calibration measurements, otherwise, make the necessary corrections (1).

11.3.2 Subtract the background count rate, $bkgd$.

$$ucr' = ucr - (bkgd/t2) \quad (17)$$

where:

$t2$ = background count time.

11.3.3 Make a correction for the ^{252}Cf radioactive decay.

$$ucr'' = ucr' \times \exp(\lambda t') \quad (18)$$

where:

λ = the decay constant for $^{252}\text{Cf} = 0.2620 \text{ yr}^{-1}$, and

t' = the time since the calibration in years.

11.3.4 Use the same count times, source transfer timing, and number of shuffles for each measurement, or correct for the differences (1).

11.3.5 Use the flux monitor matrix correction factor to correct the delayed neutron signal for matrix effects (1,2).

$$ccr = ucr'' \times CF_d(\text{flux monitor}) \quad (19)$$

where:

$CF_d(\text{flux monitor})$ is discussed in 9.4 and Ref (2);

11.3.5.1 If only one matrix is being assayed and the appropriate calibration materials were used for it, the user might use the matrix-specific calibration instead of applying the matrix correction factor.

11.3.6 No corrections are made for self-shielding and heterogeneity (1,2).

11.3.7 Use the calibration function and parameters to compute the assay result in terms of ^{235}U mass from the corrected measured response, ccr .

11.3.7.1 Waste measurements involving uranium of one enrichment generally use a linear function:

$$ccr = k_{235} m_{235} \quad (20)$$

where:

k_{235} = calibration constant for ^{235}U , and

m_{235} = mass of ^{235}U .

11.3.7.2 If a wide range of uranium enrichment is to be measured, or if plutonium was found in the passive assay, then corrections may be required (1,2,6).

11.3.8 Use isotopic information and the ^{235}U mass to get the assay result in terms of uranium mass.

$$m_{\text{uranium}} = \frac{m_{235}}{f_{235}} \quad (21)$$

where:

f_{235} = weight fraction of ^{235}U .

11.3.9 The estimate of the measurement uncertainty should include the components that cause significant effects. These generally include counting statistics, calibration errors, uncertainties in the matrix correction factor and uncertainties in the isotopic ratios. Other components may be difficult to quantify.

12. Precision and Bias

12.1 The precision and bias of shuffler measurements are functions of several interrelated factors, consequently a simple precision or bias statement is not possible (2,8,9). The interrelated factors include facility-specific procedures, matrices, chemical forms, and quantities. This section provides information but cannot substitute for critical thinking, professional skill, and verification measurements. The evaluation of the uncertainty for a shuffler assay is not a purely mathematical task, it requires detailed knowledge of the measurement method, the procedures, and the items being measured. Measurements of uncharacterized drums generally yield results of indeterminate accuracy. However, a combination of measurement methods applied to such drums may be used to estimate measurement uncertainties. Except for measurements of small quantities of nuclear material, the possibility of bias is of greater concern than the issue of inadequate precision (2,9). This section lists precision and bias statements applicable to both passive and active measurements, then statements specific to the passive mode, then statements specific to the active mode.

12.2 *Passive and Active Measurements*—Each user of this test method should estimate the precision and bias for each scrap and waste category. See Refs 2,6,7,9, and 14 as examples.

12.2.1 A comparison with another assay technique can be helpful to estimate potential bias. Figs. 8-10 are examples of such comparisons. In general, other techniques (for example, Test Method C 1133 or Test Method C 1207) are susceptible to different sources or magnitude or magnitudes of bias.

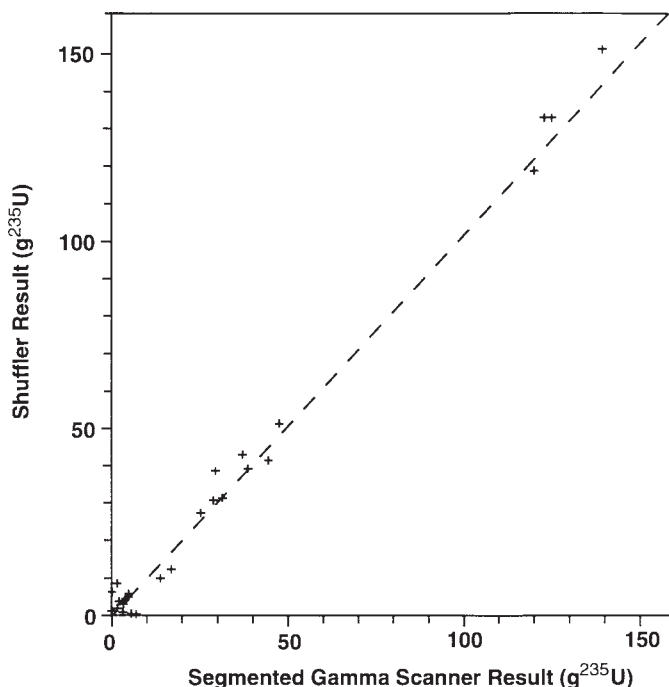

NOTE 1—The results of active measurements for the ^{235}U content of 208-litre drums are compared to the results of segmented gamma scanner (SGS) measurements (7,9). These drums contain low-density waste with unknown uranium loadings from an enrichment plant located in Portsmouth, Ohio. The matrices are alumina, low-density combustible waste, ABSORBAL, and oil-soaked 3M cloth. The segmented gamma scanner results are from a measurement of the 208-litre drum (if the transmission at 186-keV was possible) or from summing the results of measurements on 5-in. cans whose contents were poured into the drums. The measurement uncertainties for both techniques are dominated by bias rather than precision. The lack of agreement below 9 g suggests additional information (another measurement technique) is needed if a better understanding of the bias is desired.

FIG. 8 Comparison Between Active Mode and Segmented Gamma Scanner Results from an Enrichment Facility

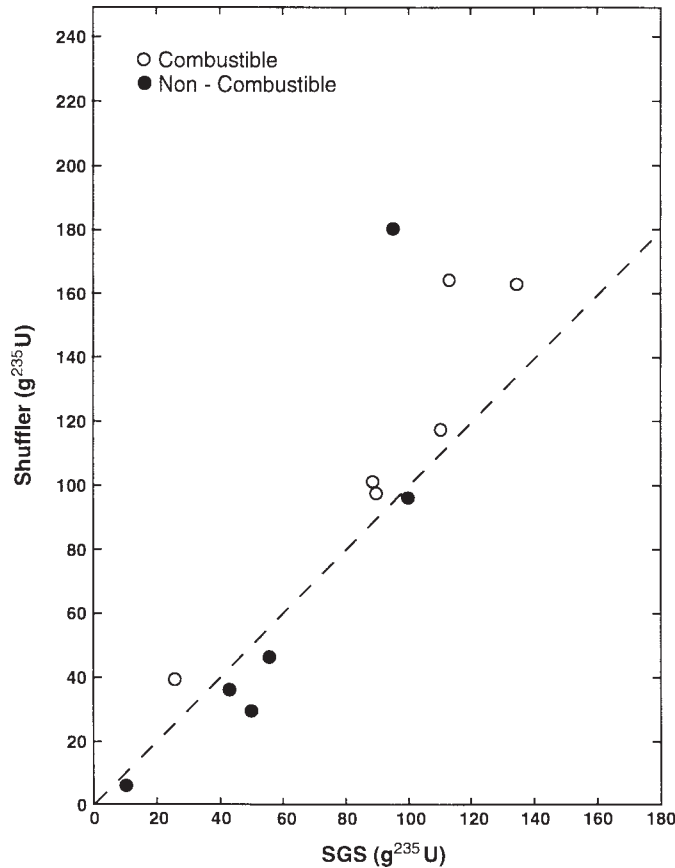

NOTE 1—The results of active measurements for the ²³⁵U content of 208-litre drums are compared to the results of segmented gamma scanner (SGS) measurements. These drums contain either low-density combustible waste or medium-density non-combustible waste from a bulk-processing facility for HEU located in Erwin, Tennessee (20). The measurement uncertainties for both techniques are dominated by bias rather than precision.

FIG. 9 Comparison Between Active Mode and Segmented Gamma Scanner Results from a Fuel Fabrication Facility

12.2.2 Calibration exercises can be helpful to estimate potential bias (2). In general, it may be difficult to determine how well the calibration matrices emulate the unknowns.

12.2.3 Destructive analysis is generally not practical as a source of bias information when the items are heterogeneous.

12.3 The precision of a shuffler measurement can be estimated using statistical calculations on the data from a single measurement or it can be evaluated by replicate measurements.

12.3.1 Longer counting times, more nuclear material, or the use of an apparatus with higher detection efficiency will improve the measurement precision.

12.4 The bias of a shuffler assay is dependent upon many factors relating to the segregation and packaging of the matrix materials as well as the physical and chemical properties of the nuclear material. If the criteria of 5.4 and 9.2 are not met, the bias is indeterminate.

12.4.1 Biases can occur if the characteristics of the calibration materials differ significantly from those of the item being measured.

12.4.2 Mixing material from different matrix segregation categories can lead to a situation where no calibration is appropriate.

12.5 Moderators and absorbers in the matrix can cause bias effects. Small quantities cause effects that can be corrected; large quantities may bias the result high or low (2).

12.5.1 Hydrogen is the element with the largest potential for causing a bias due to moderation and absorption effects. Reference 2 describes a method to determine corrections valid for hydrogen levels up to 0.04 g/cm³.

12.6 Bias effects can occur as a result of varying fill heights, heterogeneity, or item positioning because the detection efficiency is not constant over the assay volume. Spatial effects for the detection efficiency vary as much as 10 % for the totals and delayed neutron count rates, and as much as 19 % for the coincidence count rate over the volume of the assay chamber for a benign matrix (6).

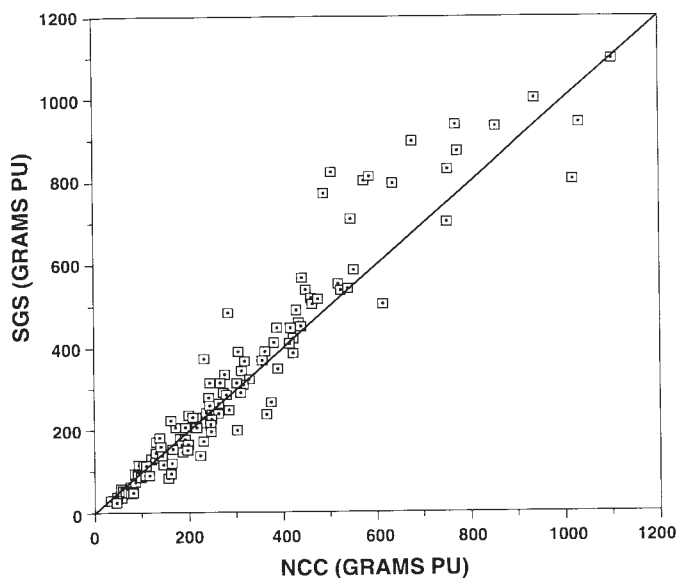

NOTE 1—The results of passive measurements for the plutonium content of 5-gal pails are compared to the results of segmented gamma scanner (SGS) measurements. The pails contain scrap and waste generated by a reprocessing facility in Aiken, South Carolina (14). The matrices have no hydrogen. The measurement uncertainties for both techniques are dominated by bias rather than precision.

FIG. 10 Comparison Between Passive Mode and Segmented Gamma Scanner Results

12.7 Calibration materials have assigned values for mass and isotopic ratios. A bias in an assigned value causes a bias in the calculated results. This bias should be made negligible.

12.8 This test method requires knowledge of the isotopic ratios to compute the total element mass from the measured response. A bias in the isotopic ratios will cause a bias in the calculated results.

12.9 Proper adjustment of electrical circuit parameters such as the pre-delay and those controlling the californium source motion can eliminate them as a possible source of significant bias (1,2).

12.10 If only plutonium is present, both the active and passive modes can be used to assay for plutonium. The passive result will generally be less biased and have better precision. The active and passive measurements are independent; a lack of agreement between the two results indicates at least one measurement is biased.

12.11 *Active Measurements*—Fig. 8 and Fig. 9 compare the results of active mode measurements of 208-litre drums with segmented gamma scanner measurements (Test Method C 1133). These items are process waste with unknown ^{235}U content. Fig. 8 compares the shuffler results to segmented gamma scanner results for low-density waste from a uranium enrichment plant (7,9). Fig. 9 compares the shuffler results to segmented gamma scanner results for two waste categories from a naval fuel fabrication plant (21). The measurement uncertainties for these results are dominated by bias effects except at very small masses. The difference between the active mode and the segmented gamma scanner results is an estimate of the bias in these measurements.

12.12 Counting statistics contribute a random error of less than 2 % (relative standard deviation) for a 1000-s assay of a 208-litre drum containing 5 g of ^{235}U . For larger quantities of ^{235}U , the random error is generally below 1 % (relative standard deviation) (2,6).

12.12.1 Use of a larger ^{252}Cf source will improve the precision of the active measurement.

12.13 Bias values of approximately 0.2 % have been reported for state-of-the-art measurements of kilogram quantities of ^{235}U in 500 cm³ containers of homogeneous product material in 1000-s count times, when compared to destructive analysis (22).

12.14 Bias values due to matrix effects of 25 % have been reported for state-of-the-art measurements of uranium and plutonium in 208-litre mock-waste drums performed during calibrations. A flux monitor correction was applied and 1000-s count times were used. The majority of the data was taken with either 5 g of HEU or 30 g of plutonium placed in a variety of matrices (2,8).

12.15 Neutron absorbers such as boron cause effects that can be corrected with the matrix correction factor when the moderator density is low (that is, H density <0.04 g/cm³). Larger quantities of moderator will cause these absorber effects to bias the measurement results (2).

12.16 Self-shielding effects for active neutron measurements are minimized when the irradiating neutron energies are kept relatively high and the nuclear material is distributed. Large quantities of moderating material in the matrix are the dominant factor affecting the irradiating neutron energies for large containers.

12.16.1 Calculations predict that a 30-g plutonium metal sphere placed in an empty drum yields 70 % of the response of 30 1-g spheres distributed uniformly in the drum (2). However, with a matrix of polyethylene shavings (estimated to contain a hydrogen

density of 0.009 g/cm³), self-shielding causes significant bias for the 1-g sphere of plutonium metal (2).

12.16.2 Calculations predict that 5 g of highly enriched uranium diluted in a small capsule (approximately 35 cm³) placed in an empty drum yields 92 % of the response of 5 g distributed uniformly (2). This result is consistent with the reported measurements.

12.16.3 Calculations predict that a 10-mg metallic uranium (93 % enriched) sphere placed in an empty drum yields 86 % of the response of 10 mg distributed uniformly. However, a 100-g sphere of uranium oxide yields 58 % of the response of 100 g distributed uniformly (8).

12.17 The active-mode background correction uses a background count at the beginning of each measurement (with the ²⁵²Cf source in the storage location). This correction reduces the bias from sources such as (α, n) reactions, the californium source in its shield, or cosmic rays to negligible levels (1,2).

12.18 *Passive Measurements*—Fig. 10 and Fig. 11 compare the results of passive mode measurements, using matrix-specific calibrations, with the results of alternative techniques. Fig. 10 compares passive measurements with segmented gamma scanner measurements (Test Method C 1133) for 5-gal (19-litre) pails containing plutonium scrap (14). Fig. 11 compares passive measurements with calorimetry. These matrices do not contain hydrogen and were generated at two plutonium purification plants. The measurement uncertainties are dominated by bias effects, except for the results at very small masses. The differences between the two techniques are an estimate of the bias in these measurements.

12.19 Counting statistics contribute a random error of less than 1 % for a 1000-s count of an item containing more than 1-g m_{eff} of PuO₂ (13). The precision is better for assays of larger quantities of plutonium.

12.20 Bias values of 2 % have been reported for state-of-the-art measurements for small containers (1-litre metal cans) of homogeneous plutonium material, when compared to destructive analysis (13). The plutonium masses ranged from 75 to 874 g; the counting times were 1000 s; and no matrix correction was applied.

12.21 Bias values of 10 % have been reported for state-of-the-art measurements of the plutonium content in 208-litre waste drums, performed during calibration. A flux monitor correction was applied and 1000-s count times were used. Most of the data is from 30 g of plutonium placed in a variety of matrices (2,8).

12.22 The bias due to cosmic-ray background can be on the order of 0.02-g m_{eff} for large dense items at sea level and can double at 2000-m elevation (4). Corrections can be made if necessary (19).

12.23 The coincidence requirement corrects the passive measurement for the presence of (α, n) neutrons. When multiplication is present, a bias can result. The bias effects due to neutron multiplication increase with plutonium mass and are affected by variations in the distribution of the plutonium and the presence of moderating and (α, n) materials.

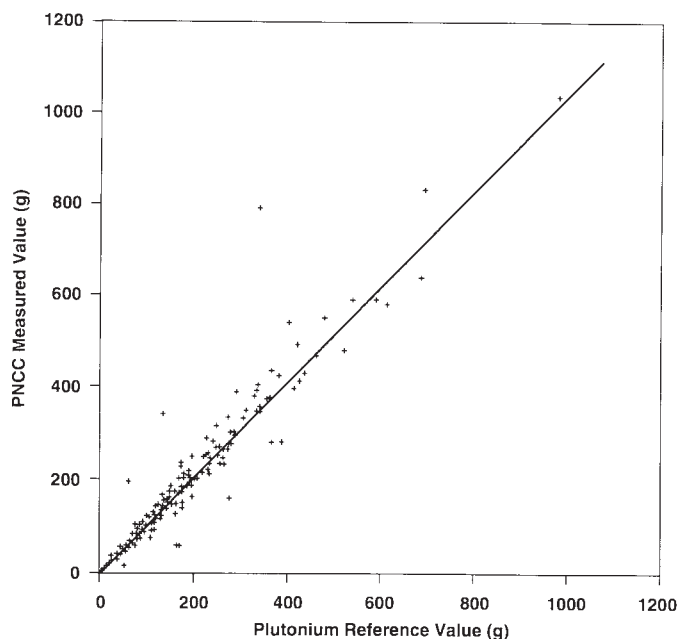

NOTE 1—The results of passive measurements for the plutonium content of small containers of scrap and waste are compared to the results of calorimetry and gamma ray isotopics measurements. The containers were generated by a plutonium R & D facility in Los Alamos. The matrices do not contain hydrogen. The measurement uncertainties are dominated by bias rather than precision. The outliers could be due to transcription errors or a bias in either technique.

FIG. 11 Comparison Between Passive Mode and Calorimetry Results

12.23.1 Waste measurements of matrices with uniformly distributed special nuclear material in 208-litre drums exhibit negligible multiplication.

12.23.2 A multiplication effect of 9 % on the neutron coincidence rate has been reported for 10-g m_{eff} of plutonium oxide (13,14). The effect will decrease if the plutonium is diluted by a matrix.

12.24 Neutron absorbers have negligible effects on the accuracy of passive coincidence measurements of unmoderated samples.

12.25 Self-shielding effects do not exist for passive neutron measurements.

13. Keywords

13.1 active neutron measurements; californium; californium-252; NDA; neutron coincidence counting; PAN; passive neutron measurements; plutonium; scrap measurements; shuffler; uranium; waste measurements

APPENDIX

(Nonmandatory Information)

X1. VOLUME WEIGHTED AVERAGE

X1.1 The cost of characterizing and storing suitable calibration materials for large sets of diverse matrices can be decreased by using the volume-weighted-average concept. The concept uses small capsules of special nuclear material and containers filled with uncontaminated matrix material to estimate the response of the instrument to different matrices (2). In general, plastic components and plastic bags are avoided because of moderating effects. Thin metallic components are preferable to plastic.

X1.2 The containers are generally standard 208-litre (55-gal) drums, 86 cm high and 57 cm in diameter. Three tubes with diameters of 3.18 cm run the length of the drums at radii of $r = 12, 20, \text{ and } 25$ cm. These radial distances are preferred because they are located at the mid-volume radii of a cylinder inside two nested cylindrical shells, all with equal volumes. Responses from sources at these radii approximate average responses for the three equal volumes.

X1.3 When the tubes are fixed in position, the containers are filled with uncontaminated matrix material for the calibration exercise. The selection of matrix materials is based on the neutron absorption and moderation properties of the material categories used in the sorting and waste segregation procedures. The neutron moderation and absorption properties of the matrix in each container should be uniform throughout the container.

X1.4 Small capsules containing the special nuclear material of interest are placed inside the tubes of the sample containers at various heights during the measurements. Self-shielding of the special nuclear material in each capsule should be evaluated. In general, the special nuclear material in the capsules will have to be diluted with a benign matrix like graphite or diatomaceous earth to approximately 0.1 g/cm^3 or less to make self-shielding effects sufficiently small. Identical capsules containing different quantities of special nuclear material in similar quantities of diluent can be used to evaluate self-shielding.

X1.5 Each matrix container will typically have measurements made at five or seven heights in each of the three tubes. If the heights are evenly spaced and the radii, r , suggested above are used, each measurement is representative of the same-sized volume element, approximately 5 % of the total drum volume. Selection of equally sized volume elements will simplify the following calculations because no weighting of the responses is required.

X1.6 The weighted average and standard deviation of the measured results is computed. Each result is weighted by the volume element it represents. The average response is representative of the response from special nuclear material distributed uniformly throughout the container. The standard deviation is indicative of the potential bias from measurements made with nonuniform distributions of special nuclear material.

REFERENCES

- (1) Rinard, P. M., "Shuffler Instruments for the Nondestructive Assay of Fissile Materials," Los Alamos report LA-12105, May 1991.
- (2) Rinard, P. M., Adams, E. L., Menlove, H. O., and Sprinkle, J. K., Jr., "Nondestructive Assays of 55-gallon Drums Containing Uranium and Transuranic Waste Using Passive/Active Shufflers," Los Alamos report LA-12446-MS, 1992.
- (3) "Non-Destructive Assay of Radioactive Waste," C. Eid and P. Bernard, Eds., *Proceedings of the Topical Meeting at Cadarache, France*, EUR-12830, November 1989.
- (4) "PANDA—Passive Nondestructive Assay of Nuclear Materials," D. Reilly, N. Ensslin, H. Smith, Jr., and S. Kreiner, Eds., LA-UR-90-732, NUREG/CR-5550, March 1991.
- (5) Menlove, H. O., and Eccleston, G. W., "High-Sensitivity Measurements for Low-Level TRU Wastes Using Advanced Passive Neutron Techniques," presented at the TRU Waste Characterization Conference, Pocatello, Idaho, August, 1992.
- (6) Sprinkle, J. K., Jr., Menlove, H. O., Ensslin, N., and Crane, T. W., "Measurements of Uranium Waste Using a Californium Shuffler," *Proceedings of the Topical Meeting at Cadarache, France*, C. Eid and P. Bernard, Eds., EUR-12890, November, 1989, p. 202.
- (7) Gross, J. C., and Wines, K. M., "Calibration Techniques and Results for the Portsmouth Cf Shuffler," presented at the XXXIV Annual Meeting of the Institute of Nuclear Materials Management, Scottsdale, Arizona, July 1993.
- (8) Rinard, P. M., Coop, K. L., Nicholas, N. J., and Menlove, H. O., "Comparison of Shuffler and Differential Die-Away-Technique Instruments for the Assay of Fissile Materials in 55-Gallon Waste Drums," Los Alamos document LA-UR-93-2649, *Journal of Nuclear Materials Management*, Vol XXII, No. IV, 1993, p. 28.
- (9) Wines, K. M., and Gross, J. C., "Comparison of Results from the Cf Shuffler and Segmented Gamma Scanner NDA Techniques," presented at the XXXV Annual Meeting of the Institute of Nuclear Materials Management, Naples, Florida, July 1994.
- (10) Menlove, H. O., "Accurate Plutonium Waste Measurements Using the ²⁵²Cf Add-a-Source Technique for Matrix Corrections," presented at the XXXIII Annual Meeting of the Institute of Nuclear Materials Management, Orlando, Florida, July 1992.
- (11) Stewart, J. E., Ferran, R. R., Menlove, H. O., Horley, E. C., Baca, J., France, S. W., and Wachter, J. R., "A Versatile Passive/Active Neutron Coincidence Counter for In-Plant Measurements of Plutonium and Uranium," presented at the 13 ESARDA Symposium, Avignon, France, May, 1991.
- (12) Pickrell, M. M., and Rinard, P. M., "Matrix and Position Correction of Shuffler Assays by Application of the Alternating Conditional Expectation Algorithm to Shuffler Data," presented at the XXXIII Annual Meeting of the Institute of Nuclear Materials Management, Orlando, Florida, July 1992.
- (13) Sprinkle, J. K., Jr., Bosler, G. E., Hsue, S.-T., Kellogg, M. P., Miller, M. C., Simmonds, S. M., and Smith, H. A., "Nondestructive Assay of Plutonium-Bearing Scrap and Waste," Los Alamos document LA-UR-89-2373 presented at the ANS meeting, San Francisco, November 1989.
- (14) Baker, L., MacMurdo, K., Miller, M. C., and Bosler, G. E., "Recent Experiences of Scrap and Waste Assay Using Neutron Coincidence Counting of Materials from F B-line at the Savannah River Site," presented at the XXXI Meeting of the Institute of Nuclear Materials Management, Los Angeles, CA, July 1990.
- (15) Krick, M. S., and Harker, W. C., "NCC User's Manual," Los Alamos report to be published.
- (16) Menlove, H. O., Abedin-Zadeh, R., and Zhu, R., "The Analyses of Neutron Coincidence Data to Verify Both Spontaneous-Fission and Fissionable Isotopes," Los Alamos report LA-11639-MS, August 1989.
- (17) "European Interlaboratory Test Measurements on Alpha-Contaminated Waste," R. Dierckx, Ed., Commission of the European Communities report EUR-12609-EN, 1990.
- (18) Hsue, S.-T., Campbell, K., and Barlich, G., "Measurement Control Program for New Special Recovery," Los Alamos report LA-10974-MS, April 1987.
- (19) Miller, D. W., and Menlove, H. O., "Cosmic-Ray-Veto Detector System," Los Alamos report LA-12469-MS, December 1992.
- (20) Menlove, H. O., Foster, L. A., and Baca, J., "NBC Operation Manual Including the Multi-Position Add-a-Source Function," Los Alamos report LA-12737-M, March 1994.
- (21) Strittmatter, R. B., Crane, T., Ensslin, N., Marks, T., Sprinkle, J. K., Jr., and Tape, J. W., "Evaluation of Nondestructive Assay Measurements at the Nuclear Fuel Services Fuel Fabrication Plant," Los Alamos report Q-1-82-424-7, April 1982.
- (22) "Safeguards and Security Progress Report," Los Alamos reports LA-10787-PR (Jan.–Dec. 1985) and LA-11120-PR (Jan.–Dec. 1986).

ASTM International takes no position respecting the validity of any patent rights asserted in connection with any item mentioned in this standard. Users of this standard are expressly advised that determination of the validity of any such patent rights, and the risk of infringement of such rights, are entirely their own responsibility.

This standard is subject to revision at any time by the responsible technical committee and must be reviewed every five years and if not revised, either reapproved or withdrawn. Your comments are invited either for revision of this standard or for additional standards and should be addressed to ASTM International Headquarters. Your comments will receive careful consideration at a meeting of the responsible technical committee, which you may attend. If you feel that your comments have not received a fair hearing you should make your views known to the ASTM Committee on Standards, at the address shown below.

This standard is copyrighted by ASTM International, 100 Barr Harbor Drive, PO Box C700, West Conshohocken, PA 19428-2959, United States. Individual reprints (single or multiple copies) of this standard may be obtained by contacting ASTM at the above address or at 610-832-9585 (phone), 610-832-9555 (fax), or service@astm.org (e-mail); or through the ASTM website (www.astm.org).