



# Standard Test Method for Determination of Total Chlorine and Fluorine in Uranium Dioxide and Gadolinium Oxide<sup>1</sup>

This standard is issued under the fixed designation C 1502; the number immediately following the designation indicates the year of original adoption or, in the case of revision, the year of last revision. A number in parentheses indicates the year of last reappraisal. A superscript epsilon ( $\epsilon$ ) indicates an editorial change since the last revision or reappraisal.

## 1. Scope

1.1 This test method covers the determination of chlorine and fluorine in nuclear-grade uranium dioxide ( $\text{UO}_2$ ) powder and pellets, nuclear grade gadolinium oxide ( $\text{Gd}_2\text{O}_3$ ) powder and gadolinium oxide-uranium oxide ( $\text{Gd}_2\text{O}_3\text{-UO}_2$ ) powder and pellets.

1.2 With a 2 gram  $\text{UO}_2$  sample size the detection limit of the method is 4  $\mu\text{g/g}$  for chlorine and 2  $\mu\text{g/g}$  for fluorine. The maximum concentration determined with a 2 gram sample is 500  $\mu\text{g/g}$  for both chlorine and fluorine. The sample size used in this test method can vary from 1 to 10 grams resulting in a corresponding change in the detection limits and range.

1.3 *This standard does not purport to address all of the safety concerns, if any, associated with its use. It is the responsibility of the user of this standard to establish appropriate safety and health practices and determine the applicability of regulatory limitations prior to use.*

## 2. Referenced Documents

### 2.1 ASTM Standards:

C 753 Specification for Nuclear-Grade, Sinterable Uranium Dioxide Powder<sup>2</sup>

C 776 Specification for Sintered Uranium Dioxide Pellets<sup>2</sup>

C 888 Specification for Nuclear-Grade Gadolinium Oxide ( $\text{Gd}_2\text{O}_3$ ) Powder

C 922 Specification for Sintered Gadolinium Oxide—Uranium Dioxide Pellets

D 1193 Specification for Reagent Water<sup>3</sup>

## 3. Summary of Test Method

3.1 The halogens are separated from the test materials by pyrohydrolysis in a quartz tube with a stream of wet oxygen or air at a temperature of 900 to 1000°C. (1-4) Chloride and fluoride are volatilized simultaneously as acids, absorbed in a buffer solution as chloride and fluoride and measured with ion selective electrodes (4-6).

## 4. Significance and Use

4.1 The method is designed to show whether or not the tested materials meet the specifications as given in either Specification C 753, C 776, C 888 or C 922.

## 5. Interferences

5.1 The buffer controls the pH of the measured solution to avoid hydroxide ion interference or the formation of hydrogen complexes with fluoride.

5.2 Bromide, iodide, cyanide and sulfide, if present in the condensate, interfere in the measurement of chloride with ion-selective electrodes, but have very little effect upon the measurement of fluoride with ion-selective electrodes.

5.3 As the ionic activity of the chloride and fluoride ions is temperature dependent, the standard solutions and sample solutions should be measured at the same temperature.

## 6. Apparatus

6.1 *Pyrohydrolysis Equipment*, the assembly of suitable equipment is shown in Fig. 1.

6.2 *Gas Flow Regulator and Flowmeter*.

6.3 *Hot Plate*, used to warm the water saturating the sparge gas to 50–80°C.

6.4 *Combustion Tube Furnace*, having a bore of about 32 mm with a length of about 300 mm and the capability of maintaining a temperature of  $950 \pm 25^\circ\text{C}$ . Combustion tube furnaces with different dimensions may be satisfactory. Temperatures between 900 and 1000°C have been found to be satisfactory.

6.5 *Quartz Reaction Tube* (Fig. 2)—The exit end should not extend more than 50 mm beyond the furnace with a ground joint connecting to the delivery tube. The delivery tube extends into a polyethylene or Pyrex absorption vessel with a tip capable of giving a stream of very fine bubbles. A second absorption vessel connected in series, may be necessary to ensure complete collection of the fluorine and chlorine from the sample.

6.6 *Combustion Boat*, a ceramic, platinum or quartz boat with a 10 mL capacity (approx. 90–100 mm long, 13 mm wide, and 10 mm high). Boats with different dimensions may be satisfactory.

<sup>1</sup> This test method is under the jurisdiction of ASTM Committee C26 on Nuclear Fuel Cycle and is the direct responsibility of Subcommittee C26.05 on Methods of Test.

Current edition approved June 10, 2001. Published September 2001.

<sup>2</sup> *Annual Book of ASTM Standards*, Vol 12.01.

<sup>3</sup> *Annual Book of ASTM Standards*, Vol 11.01.

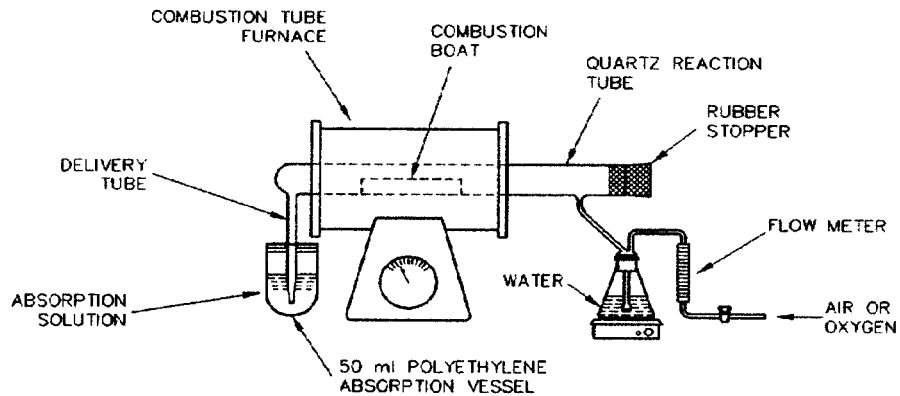

FIG. 1 Pyrohydrolysis Equipment

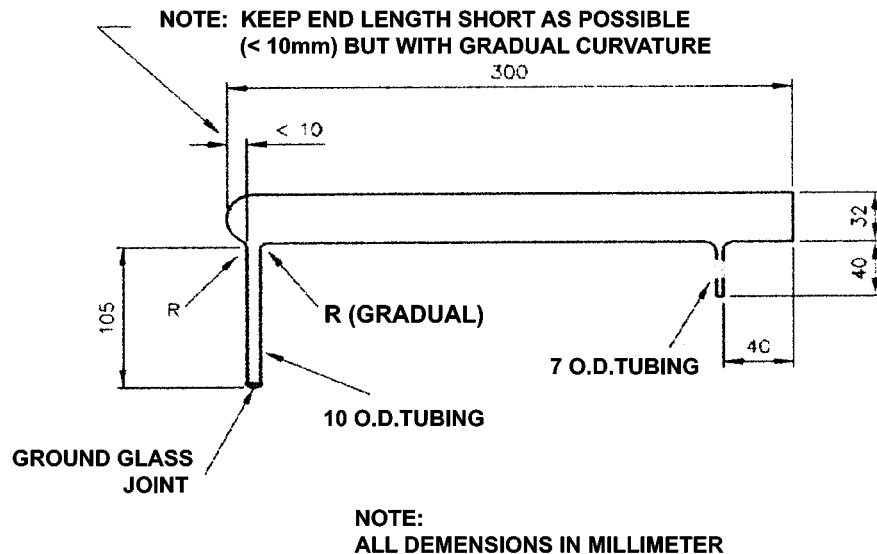

FIG. 2 Quartz Reaction Tube

6.7 *Absorption Vessel*, a 50-ml polyethylene graduate or tube is satisfactory.

6.8 *Ion-Selective Electrodes*, fluoride-selective activity electrode<sup>4</sup>, chloride-selective activity electrode<sup>5</sup>. Combination electrodes may be suitable.

6.9 *Double-Junction Reference Electrode*<sup>6</sup>, such as a silver-silver chloride with appropriate filling solutions.

6.10 *pH/mV Meter*—The meter should have minimum resolution of 1 mV.

6.11 *Magnetic Stirrer*.

6.12 *Beakers*, 50 mL polyethylene.

## 7. Reagents

7.1 *Purity of Reagents*—Reagent grade chemicals shall be used in all tests. Unless otherwise indicated, it is intended that all reagents conform to the specifications of the Committee on

Analytical Reagents of the American Chemical Society, where such specifications are available.<sup>7</sup> Other grades may be used, provided it is first ascertained that the reagent is of sufficiently high purity to permit its use without lessening the accuracy of the determination.

7.2 *Accelerator*—Two accelerators have been investigated for this system, halogen free  $U_3O_8$  and a flux of sodium tungstate and tungsten trioxide. (1, 2) Halogen free  $U_3O_8$  requires no special preparation before use but will require a longer pyrohydrolysis period. The flux of sodium tungstate ( $Na_2WO_4$ ) with tungsten trioxide ( $WO_3$ ) may reduce the pyrohydrolysis period by half but it requires the following special preparation. Dehydrate 165 g of  $Na_2WO_4$  in a large platinum dish. Transfer the dried material to a mortar, add 116 g of  $WO_3$ , and grind the mixture to ensure good mixing.

<sup>7</sup> *Reagent Chemicals, American Chemical Society Specifications*, American Chemical Society, Washington, D.C. For suggestions on the testing of reagents not listed by the American Chemical Society, see *Reagent Chemicals and Standards*, by Joseph Rosin, D. Van Nostrand Company, Inc., New York, New York, and the *United States Pharmacopeia*.

<sup>4</sup> The Orion Model 9409 has been found satisfactory.

<sup>5</sup> The Orion Model 9617 has been found satisfactory.

<sup>6</sup> The Orion Model 9002 has been found satisfactory.

Transfer the mixture into a platinum dish and heat with a burner for 2 h. Cool the melt, transfer the flux to a mortar and grind to a coarse powder. Store the flux in an airtight bottle. Mix about 8 g of flux with each portion of sample to be pyrohydrolyzed.

7.3 *Buffer Solution (0.1 M)*—Dissolve 10 g, potassium acetate ( $\text{KC}_2\text{H}_3\text{O}_2$ ) in water, add 5 mL of acetic acid ( $\text{CH}_3\text{CO}_2\text{H}$ , sp gr 1.05), and dilute to 1 L. Other buffers may be satisfactory. It will be necessary to validate the buffers and operating conditions with spike recovery determinations.

7.4 *Chloride, Standard Solution (100  $\mu\text{g Cl/mL}$ )*—Dissolve 0.165 g of dry sodium chloride ( $\text{NaCl}$ ) in water and dilute to 1 L. Commercially prepared standard solutions may be used.

7.5 *Fluoride, Standard Solution (50  $\mu\text{g F/mL}$ )*—Dissolve 0.111 g of dried sodium fluoride ( $\text{NaF}$ ) in water and dilute to 1 L. Store the solution in a polyethylene bottle. Commercially prepared standard solutions may be used.

7.6 *Compressed Oxygen or Air.*

7.7 *Purity of Water*—Unless otherwise indicated, references to water shall be understood to mean reagent water conforming to Specification D 1193, Type I.

## 8. Procedure

8.1 Adjust the pyrohydrolysis system to operating condition as follows:

8.1.1 Heat the furnace to  $950 \pm 25^\circ\text{C}$ . (See 6.4).

8.1.2 Fill the water reservoir and heat to  $50$  to  $80^\circ\text{C}$ .

8.1.3 Adjust the gas flow to 1 to 2 L/min.

8.1.3.1 The furnace temperature, the gas flow and the dimensions of the delivery tube tip are critical variables that will affect the spike recovery of the method.

8.2 Flush the reaction tube and boat with moist oxygen.

8.3 Run a pyrohydrolysis blank using a halogen-free uranium oxide or gadolinium oxide according to the procedure in 8.5.

8.3.1 Alternatively an empty combustion boat can be used for the pyrohydrolysis blank.

8.3.2 A blank run should be made each day and after any sample that contains abnormally high levels of chlorine or fluorine.

8.4 Run samples, controls, duplicates and spikes in accordance with the user's quality assurance control plan and requirements.

8.5 *Sample Pyrohydrolysis:*

8.5.1 Pellets should be crushed prior to analysis.

8.5.2 Weigh 1 to 10 g of sample and spread in the combustion boat. If an accelerator is desired, mix 4 g of  $\text{U}_3\text{O}_8$  accelerator or 8 g of the tungstate flux with the sample before spreading in the boat. A flux to sample ratio of 1 has been found to work satisfactorily. Other ratios may be applicable as determined by the analyst.

8.5.3 Place 15 mL of acetate buffer solution in the collection flask and submerge the delivery tip in the solution.

8.5.4 Remove the stopper from the entrance of the reaction tube and insert the boat into the hot area of the furnace. Quickly stopper the furnace tube.

8.5.5 Check the gas flow and adjust to 1 to 2 L/min.

8.5.6 Continue the reaction for 1 hour. Thirty minutes may be sufficient with the tungstate flux.

NOTE 1—The time required to complete the pyrohydrolysis will vary with differences in accelerator type, equipment and sample type. To establish the total time required for complete pyrohydrolysis, replace the buffer solution at 15 to 30 minute intervals and continue the reaction until complete.

8.5.7 When the pyrohydrolysis is completed, transfer the buffer solution to a 25-mL volumetric flask. Rinse the delivery tube (including inside) and collection tube with a minimum of buffer solution. Make up to volume with buffer.

8.6 *Chloride and Fluoride Measurement:*

8.6.1 Assemble the mV meter and ion specific electrode and take the meter readings in accordance with the manufacturer's instructions.

8.6.2 Add 0, 0.1, 0.2, 0.4, 0.8, 1, 2, 4 and 10 mL of the chloride and the fluoride solutions prepared in 7.4 and 7.5 to separate 25 mL flasks. Dilute each with buffer solution. Prepare calibration curves by plotting the millivolt readings of the standards versus the concentration in micrograms per 25 mL on semi-log paper. The concentration of chloride covers 10  $\mu\text{g}/25$  mL to 1000  $\mu\text{g}/25$  mL and the fluoride from 5  $\mu\text{g}/25$  mL to 500  $\mu\text{g}/25$  mL.

8.6.3 Use one half of the diluted sample from 8.5.7 for each of the halide determinations. Read the concentrations from the calibration curves. Alternatively the spike addition technique may be applicable as determined by the analyst.

NOTE 2—The chloride and fluoride measurements may be determined using ion chromatography. Appropriate buffer solutions that are compatible with ion chromatography, will be necessary. The solutions will require spike recovery test work.

## 9. Calculations

9.1 *Chlorine*—Calculate as follows:

$$\text{Cl, } \mu\text{g/g} = \frac{(C - B)}{W} \quad (1)$$

where:

$C$  = micrograms of total chlorine in absorber solution,

$B$  = micrograms of total chlorine in the pyrohydrolysis blank, and

$W$  = sample weight in grams.

9.2 If a second sample solution was generated in a secondary impinger vessel as described in 6.5 calculate the result of the second impinger in the same manner as 9.1. The total micrograms of chlorine in the sample is the sum of both impingers.

9.3 *Fluorine*—Calculate as follows:

$$\text{F, } \mu\text{g/g} = \frac{(F - B)}{W} \quad (2)$$

where:

$F$  = micrograms of total fluorine in absorber solution,

$B$  = micrograms of total fluorine in the pyrohydrolysis blank, and

$W$  = sample weight in grams.

9.4 If a second sample solution was generated in a secondary impinger vessel as described in 6.5 calculate the result of the second impinger in the same manner as 9.3. The total micrograms of fluorine in the sample is the sum of both impingers.

**TABLE 1 Standard Deviation—Uranium Dioxide**

Sample Type	Element	Concentration (µg/g)	Standard Deviation (µg/g)	Determinations
UO <sub>2</sub> powderA	Fluorine	28	2	20
UO <sub>2</sub> powderA	Chlorine	38	4	20
UO <sub>2</sub> powderB	Fluorine	18	2	20

**TABLE 2 Standard Deviation—Gadolinium Oxide**

Sample Type	Element	Spike (µg)	Mean (µg)	Standard Deviation	Bias Estimate	Number of Determinations
Gd <sub>2</sub> O <sub>3</sub> -UO <sub>2</sub> pellets	Fluorine	50	49	4	-1	31
Gd <sub>2</sub> O <sub>3</sub> -UO <sub>2</sub> pellets	Chlorine	50	50	5	0	31

## 10. Precision and Bias

### 10.1 Uranium Dioxide:

10.1.1 *Precision*—The standard deviation for the method is given in Table 1. The data were obtained over several months by different analysts in laboratory A.

10.1.2 *Bias*—No information can be presented on the bias

of the procedure because no material having an accepted reference value is available. The bias of the method is being determined by spiking a sample of uranium oxide. The spike data will be available on or before January 1, 2004.

10.1.3 The supporting data for Table 1 are available from ASTM headquarters.

### 10.2 Gadolinium Oxide:

10.2.1 *Precision*—The standard deviation for the method is shown in Table 2. The data were obtained during a one month period using three different furnaces.

10.2.2 *Bias*—There is no accepted reference material available. The bias of the method was evaluated by spiking a sample of Gd<sub>2</sub>O<sub>3</sub>-UO<sub>2</sub> pellets. The data in Table 2 were obtained during a one month period using three different furnaces at laboratory B.

10.2.3 The supporting data for Table 2 are available from ASTM headquarters.

## 11. Keywords

11.1 chlorine; fluorine; gadolinium oxide; uranium dioxide

## REFERENCES

- (1) American Standards Association, Inc., "Referee Methods for the Chemical Analysis of Nuclear Fuels," ASA N5.7, 1965, p. 37.
- (2) Powell, R.H., and Menis, O., "Separation of Fluoride from Inorganic Compounds by Pyrolysis," Analytical Chemistry, ANCHA, Vol 30, 1958, p. 1546.
- (3) Warf, J.C., Cline, W.E., and Tevebaugh, R.D., "Pyrohydrolysis in the Determination of Fluoride and Other Halides," Analytical Chemistry, ANCHA, Vol 26, 1954, p. 342.
- (4) Plucinski, C.E., "Determination of Microgram Quantities of Fluoride in Metal Oxides," USAEC Document BNWL-601, AEROB, 1968.
- (5) Frant, M.S., and Ross, J.W., Jr., "Electrode for Sensing Fluoride Ion Activity in Solution," Science, KAGTA, Vol 154, 1966, p. 1553.
- (6) Rechnitz, G.A., "Ion-Selective Electrodes," Chemical and Engineering News, CENEVA, Vol 25, 1967, p. 1946.

*The American Society for Testing and Materials takes no position respecting the validity of any patent rights asserted in connection with any item mentioned in this standard. Users of this standard are expressly advised that determination of the validity of any such patent rights, and the risk of infringement of such rights, are entirely their own responsibility.*

*This standard is subject to revision at any time by the responsible technical committee and must be reviewed every five years and if not revised, either reapproved or withdrawn. Your comments are invited either for revision of this standard or for additional standards and should be addressed to ASTM Headquarters. Your comments will receive careful consideration at a meeting of the responsible technical committee, which you may attend. If you feel that your comments have not received a fair hearing you should make your views known to the ASTM Committee on Standards, at the address shown below.*

*This standard is copyrighted by ASTM, 100 Barr Harbor Drive, PO Box C700, West Conshohocken, PA 19428-2959, United States. Individual reprints (single or multiple copies) of this standard may be obtained by contacting ASTM at the above address or at 610-832-9585 (phone), 610-832-9555 (fax), or service@astm.org (e-mail); or through the ASTM website (www.astm.org).*