



Standard Test Method for Inspection and Verification of Hydrometers¹

This standard is issued under the fixed designation E 126; the number immediately following the designation indicates the year of original adoption or, in the case of revision, the year of last revision. A number in parentheses indicates the year of last reapproval. A superscript epsilon (ε) indicates an editorial change since the last revision or reapproval.

This standard has been approved for use by agencies of the Department of Defense.

1. Scope

1.1 This test method describes the principles, apparatus, and procedures for the inspection and verification of glass hydrometers of the constant-mass, variable-displacement type. It is intended to apply to ASTM hydrometers as well as to glass hydrometers in general.

1.2 The values stated in inch-pound units are to be regarded as the standard. The metric equivalents of inch-pound units may be approximate.

1.3 *This standard does not purport to address all of the safety concerns, if any, associated with its use. It is the responsibility of the user of this standard to establish appropriate safety and health practices and determine the applicability of regulatory limitations prior to use.*

2. Referenced Documents

2.1 *ASTM Standards:*

D 1265 Practice for Sampling Liquefied Petroleum (LP) Gases—Manual Method²

E 77 Test Method for Inspection and Verification of Thermometers³

E 344 Terminology Relating to Thermometry and Hydrometry³

3. Terminology

3.1 *Definitions:*

3.1.1 The definitions given in Terminology E 344 apply.

3.2 *Definitions of Terms Specific to This Standard:*

3.2.1 *API gravity, n*—the gravity obtained from the following relationship:

$$\text{API Gravity, deg} = 141.5/(\text{sp gr } 60/60 \text{ } ^\circ\text{F}) - 131.5 \quad (1)$$

3.2.2 *density, n*—the mass of a unit volume of material.

3.2.3 *specific gravity, n*—the ratio of the mass of a given volume of material at a stated temperature to the mass of an equal volume of gas-free distilled water at a stated temperature, expressed by

$$\text{Specific Gravity } x/x \text{ F (or } y/y \text{ C)} \quad (2)$$

where *x* is usually 60° and *y* is usually 15.56 °C.

3.2.4 *thermo-hydrometer, n*—a glass hydrometer having a thermometer combined with a hydrometer in one instrument.

3.2.5 Other descriptions of terms relating to thermometers are included in Test Method E 77.

4. Significance and Use

4.1 The purpose of this test method is to establish a common method by which manufacturers and users of hydrometers may make tests to establish the validity of their readings in use or as a standard for comparison of hydrometer performance for evaluation or selection purposes, or both.

4.2 The goal is to provide a standard method that is simple, easily understood, and which can be performed by the end user in the hope that it will result in a better understanding of hydrometers.

5. Apparatus

5.1 *Graduated Metal Scales*, of the conventional type, for checking linear dimensions. If more convenient, metal templates may be used on which lines are ruled at suitable distances from reference points corresponding to the maximum and minimum values of the specified dimensions.

5.2 *Micrometers*, of the conventional type, for checking diameters.

5.3 *Comparators*, for the verification of hydrometers. Suitable types are described in Appendix X1.

5.4 *Equipment* for checking the thermometers of thermo-hydrometers is described in Test Method E 77.

6. Reference Standards

6.1 *Primary Standard Hydrometers*—Primary standard hydrometers should have similar dimensions and shape to the instruments to be tested, but more finely subdivided. For example, if the instruments to be tested are subdivided to 0.0005 sp gr, the primary standards would have graduations of 0.0002 or 0.0001 sp gr. Primary standards must be calibrated by a laboratory (such as the National Institute of Standards and Technology) capable of testing instruments of such precision. Corrections must be stated to one tenth of a scale division. Primary standards should be reverified at regular intervals.

¹ This test method is under the jurisdiction of ASTM Committee E-20 on Temperature Measurement and is the direct responsibility of Subcommittee E20.05 on Liquid-in-Glass Thermometers and Hydrometers.

Current edition approved May 15, 1992. Published July 1992. Originally published as E 126 – 59 T. Last previous edition E 126 – 88¹.

² *Annual Book of ASTM Standards*, Vol 05.01.

³ *Annual Book of ASTM Standards*, Vol 14.03.

NOTE 1—The specific gravities of liquids used in testing hydrometers may be obtained by hydrostatic weighing instead of by the use of primary standards as described above. Details of the hydrostatic weighing apparatus can be found in the *Dictionary of Applied Physics*⁴ or “Density of Solids and Liquids.”⁵

6.2 *Secondary Standard Hydrometers*—Secondary standard hydrometers are more suitable and have adequate sensitivity for most work. These standards should have similar dimensions and shape to the instruments to be verified, and should have the same graduation interval. Thus, one standard may be used to check the entire range of the instrument to be tested. Secondary standards shall be verified against primary standards by a laboratory competent to conduct such tests, with corrections stated to one-tenth scale division. Reverification should be done at regular intervals.

7. Procedure

7.1 Dimensional Inspection:

7.1.1 Check the lineal dimensions and diameters by comparing the hydrometer with the appropriate device described in 5.1 and 5.2.

7.1.2 Inspect the hydrometers for correctness of graduation spacing. API and Baumé hydrometers are graduated with equal spacing. The interval between graduations of density and specific gravity hydrometers is smaller near the bottom of the scale. The proper spacing can be obtained from the following formula:

$$l = L \times d_2/d \times (d - d_1)/(d_2 - d_1) \quad (3)$$

where:

l = distance from the top line to any line, d , between the top and the bottom,

L = distance between the top and the bottom graduations of the scale,

d_2 = density, or specific gravity, of the bottom line, and

d_1 = density, or specific gravity, of the top line.

7.1.3 Check the scale of alcoholometers graduated to read percent of alcohol by weight or by volume by comparison with the values for master scales given in the “Standard Density and Volumetric Tables.”⁶

7.2 Verification:

7.2.1 *General Considerations*—The details of procedure described in the following paragraphs are, in general, the ones employed at the National Institute of Standards and Technology in calibrating hydrometers, and it will be helpful to follow them to such extent as the need for accuracy requires.

7.2.1.1 In order that readings shall be uniform and reproducible, the hydrometer must be clean, dry, and at the temperature of the liquid before immersing to take a reading. It is particularly important that the stem be clean so that the liquid will rise uniformly around the stem and merge into an imperceptible film on the stem.

7.2.1.2 *Cleanliness*—The readiness with which proper

cleanliness can be obtained depends somewhat on the character of the liquid. Certain liquids, such as mineral oils and strong alcoholic mixtures, adhere to the stem very readily. In such cases, wiping with a lint-free cloth moistened with acetone or alcohol and drying immediately before each reading is usually sufficient. On the other hand, with weak aqueous solutions of sugar, salts, acids, and alcohol, scrupulous cleaning of the stem is required. For such liquids, two methods for preparing instruments for testing are in common use. In one method, hydrometers are dipped in a mixture of one part concentrated sulfuric acid and two parts fuming sulfuric acid, thoroughly rinsed with water, and dried by wiping with a clean cloth. In the other method, hydrometers are washed with soap and water, dried, and wiped with a cloth moistened with alcohol to remove any residual soap film. The stems can usually be kept clean during the testing by wiping with a lint-free cloth moistened with alcohol (preferably absolute) and drying before each reading.

7.2.1.3 *Influence of Temperature*—In order that a hydrometer may correctly indicate the density or strength of a specified liquid, it is essential that the liquid be uniform throughout and at the temperature specified on the instrument. In comparing two hydrometers having the same standard temperature and made of the same type of glass, however, the temperature of the liquid need not be considered since the correction required due to variation from the standard temperature is the same for both instruments. But the temperatures of the liquid, the hydrometers, and the surrounding atmosphere should be nearly equal during the observation; otherwise, the temperature of the liquid will be changing, causing differences in density. To ensure uniformity in the liquid, thorough mixing is required shortly before the observations are made.

7.2.1.4 *Influence of Surface Tension*—When a hydrometer is floated in a liquid, a small quantity of the liquid rises about the stem to form a meniscus. This liquid adhering to the stem above the general level of the liquid in which the instrument is floating has the same effect as adding to the mass of the hydrometer, thus increasing the depth of immersion.

7.2.1.5 Because a hydrometer will indicate differently in two liquids having the same density but different surface tensions, and since surface tension is a specific property of liquids, it is necessary to specify the liquid for which a hydrometer is intended. Although hydrometers of equivalent dimensions may be compared, without error, in a liquid differing in surface tension from the specified liquid, the results of comparisons of dissimilar instruments in such a liquid must be corrected for the effect of the surface tension.

7.2.1.6 In many liquids spontaneous changes in surface tension occur due to the formation of surface films of impurities, which may come from the apparatus, the liquid, or the air. Errors from this cause may be avoided by the use of liquids not subject to such changes. However, if the liquid used is different in surface tension from the specified liquid, a correction is required when dissimilar instruments are compared, as mentioned above. A second method of avoiding these errors is to purify the surface of the test liquid by causing an overflow of the liquid before making an observation.

⁴ *Dictionary of Applied Physics*, MacMillan and Co., London, Vol 3, p. 439.

⁵ “Density of Solids and Liquids,” National Institute of Standards and Technology, *Circular No. 487*.

⁶ “Standard Density and Volumetric Tables,” National Institute of Standards and Technology, *Circular No. 19*.

7.2.1.7 The necessity for such special manipulation is confined to the reading of hydrometers in liquids that are subject to surface contamination. Such, in general, are aqueous solutions or mixtures of acids, alkalies, salts, sugar, and weak alcoholic mixtures. Oils, alcoholic mixtures of strength above 40% by volume, and other liquids of relatively low surface tension are not, in general, liable to surface contamination sufficient to cause appreciable changes in hydrometer readings.

7.2.1.8 *Test Liquids*—Hydrometers should be calibrated in the liquids in which they are to be used; if this is not possible, a liquid should be selected which has the same, or nearly the same, surface tension. The liquids in Table 1 are suggested as suitable, although any liquid of proper density and surface tension may be substituted. Intermediate densities may be obtained by mixing.

7.2.1.9 *Ventilation*—Adequate ventilation is desirable with some of the liquids used in calibration. Care must be taken, however, that the ventilating method does not cause strong air currents or drafts, since such movement of air might influence the calibration.

7.2.2 *Hydrometers for Liquids Having Low Surface Tension:*

7.2.2.1 Use either of the comparators described in X1.1 and X1.2.

7.2.2.2 Introduce into the comparator a sufficient amount of the appropriate test liquid to float the hydrometers with at least 1 in. (25 mm) between the bottom of the instrument and the inside bottom of the comparator. Pour the liquid down the side of the comparator to avoid the formation of air bubbles.

7.2.2.3 Stir the liquid, avoiding the formation of air bubbles, and then introduce a standard hydrometer into the jar. Slowly immerse the hydrometer to slightly beyond the test point and

allow to float freely. Read the hydrometer as directed in 7.2.2.4. Remove the standard hydrometer and introduce the instrument to be checked and read it. Remove this instrument and again immerse the standard hydrometer and read it. Average the two readings of the standard hydrometer. If the comparator is large enough, the standard hydrometer and the instrument to be checked may be placed in the comparator at the same time, and readings made on both instruments.

7.2.2.4 *Method of Reading*—Observe a point slightly below the plane of the liquid surface and then raise the line of vision until this surface, seen as an ellipse, becomes a straight line. The point where this line cuts the hydrometer scale is the reading of the instrument. Holding a white card behind the comparator just below the liquid level will improve the visibility of the surface. Estimate to one-tenth scale division.

7.2.2.5 Repeat the procedure outlined in 7.2.2.1-7.2.2.3 for each hydrometer to be verified with two or more test liquids of different densities within the range of the hydrometer.

NOTE 2—Provided the temperature is fairly constant, two or even three hydrometers can be read before a second reading of the standard hydrometer has to be made. In practice, it is easier to verify a number of hydrometers at one test point at a time before proceeding with the next.

7.2.3 *Hydrometers for Liquids Having High or Variable Surface Tension:*

7.2.3.1 Use the comparator described in X1.2.

7.2.3.2 The procedure for making checks is the same as that given in 7.2.2.2-7.2.2.5, except that stirring is done by the propeller just before a reading is made in order to ensure homogeneity of the liquid and to provide a fresh surface.

7.2.4 *Hydrometers for Liquids Having High Vapor Pressure:*

7.2.4.1 Use the comparator described in X1.3.

7.2.4.2 Insert the hydrometer in the comparator and attach the cover plate. Connect the source of supply of propane or normal butane to the inlet valve and ascertain that the connections are free from leaks. Open the outlet valve and purge the connections by opening the inlet valve slightly.

7.2.4.3 When the connections have been purged, close the outlet and vent valves and open the inlet valve, permitting the liquid to enter the comparator, until it is completely full. If necessary, the vent valve may be opened slightly to permit complete filling, after which it should be closed.

7.2.4.4 When the comparator has been filled, close the inlet valve and open the outlet valve, permitting the liquid to be withdrawn completely and the pressure inside the comparator to be reduced to that of the atmosphere.

7.2.4.5 Close the outlet valve and open the inlet valve, filling the comparator to a level at which the enclosed hydrometer floats freely. If the vapor pressure is too high to permit adequate filling, cool the comparator further. This is most readily accomplished by repetition of the purging operation. When the comparator is adequately filled, close the inlet valve and examine the apparatus for leaks. If any are detected, withdraw the liquid, correct the leaky condition and repeat the purging and filling operations.

7.2.4.6 Disconnect the comparator from the source of supply of test liquid and place it in a water bath maintained at 60.0 ± 0.5 °F (15.6 ± 0.3 °C) until thermal equilibrium has been

TABLE 1 Liquids Having Suitable Surface Tensions for Comparison Tests

| Specific Gravity, 60/60°F | Liquid |
|--|--|
| Hydrometers for Light Liquids Other than Alcohol | |
| 0.5077 | pure grade propane ^A |
| 0.5844 | pure grade <i>n</i> -butane ^A |
| 0.5967 | dimethylpropane |
| 0.6247 | isopentane |
| 0.6310 | <i>n</i> -pentane |
| 0.6540 | 2,2-dimethylbutane |
| 0.7504 | cyclopentane |
| 0.6962 | isooctane |
| 0.8718 | toluene |
| 1.070 | 3-methylsulfolane |
| 1.100 | safrole |
| 1.600 | carbon tetrachloride |
| Hydrometers for Alcohol | |
| 0.750 to 1.000 | ethanol and water |
| Hydrometers for Heavy Liquids | |
| 1.000 to 1.830 | sulfuric acid - water mixtures |
| 1.830 to 2.000 | Thoulet solutions (prepared by adding iodide and mercuric iodide to water) |

^A Because there are at present no standardized hydrometers available in the 0.500 to 0.600 sp gr range, pure grade propane and *n*-butane may be used as standardizing liquids. Orders should carry the notation "For ASTM Hydrometer Standard—show specific gravity on label." The specific gravity value given on the label will be based on a spectrographic, freezing point, or chromatographic analysis of the material and will be accurate to ±0.0002. In the use of these materials care should be exercised to observe the safety precaution given in Practice D 1265.

obtained. To accelerate thermal adjustment, occasionally remove the comparator from the water bath, tilt to a horizontal position, rock gently a few times to ensure mixing, and replace in the water bath. Exercise care to prevent damage to the hydrometer.

7.2.4.7 Remove the comparator from the water bath and observe the specific gravity as promptly as possible, following the procedure outlined in 7.2.2.4 while the hydrometer is floating freely.

7.2.4.8 Withdraw the liquid and repeat the verification with a second sample. The two observations should be considered suspect if they differ by more than 0.0005. The two readings should be averaged in calculating the correction. Take the specific-gravity value furnished by the producer of the test liquid being used as the true value for purposes of correction calculation.

8. Precision and Bias

8.1 Using this test method, an operator can expect duplicate tests of a given hydrometer to yield readings which agree within 0.5 % of full scale.

8.2 End user should consult manufacturer if test results differ from manufacturer's results by more than 0.5 % of full scale.

8.3 No bias has been determined for this test method.

9. Keywords

9.1 comparators; hydrometers; reference standards; specific gravity; surface tension; verification

APPENDIX

(Nonmandatory Information)

X1. APPARATUS

X1.1 *Comparator*—equipped with stirrers is suitable for verifying hydrometers designed for use in liquids of low surface tension. Any clear-glass jar can be used, provided it has sufficient depth that the hydrometers can float freely at least 25 mm above the inside bottom. The diameter shall be large enough so that there will be at least 12.5 mm between the inner wall and any hydrometer immersed in the jar, and also at least 12.5 mm between hydrometers, if the standard and the hydrometer to be tested are immersed at the same time.

X1.1.1 *Stirrer*—shall consist of an annular ring of glass or metal with a handle of sufficient length so that it can be conveniently moved up and down when stirring the liquid.

X1.2 *Comparator*—suitable for verifying hydrometers designed for use in liquids of high or variable surface tension is shown in Fig. X1.1.

X1.3 *Comparator*—suitable for verifying hydrometers in liquids of high vapor pressure is shown in Fig. X1.2. The working pressure of the unit shall be not less than 200 psig (1.40 MPa).

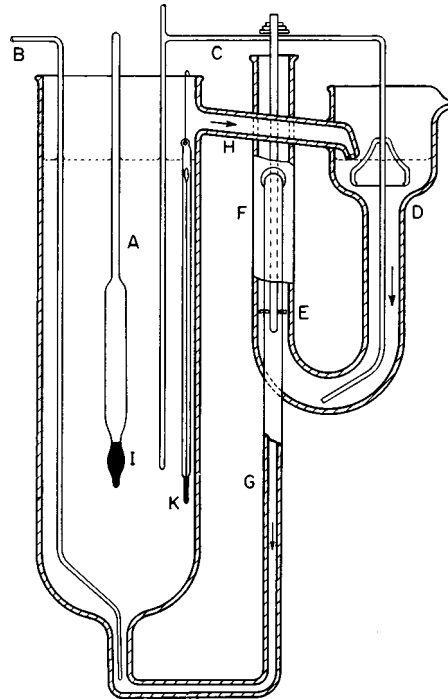

- A, cylinder containing the test liquid.
- B, glass tube for filling and emptying A.
- C, siphon for removing the liquid from D into A.
- E, propeller that stirs the liquid and raises it in the tube, F, making it flow through G into A and through the cross tube, H, into D.
- I, hydrometer.
- K, thermometer.

FIG. X1.1 Cross Section of Hydrometer Comparator Suitable for Verifying Hydrometers Designed for Use in Liquids of High or Variable Surface Tension

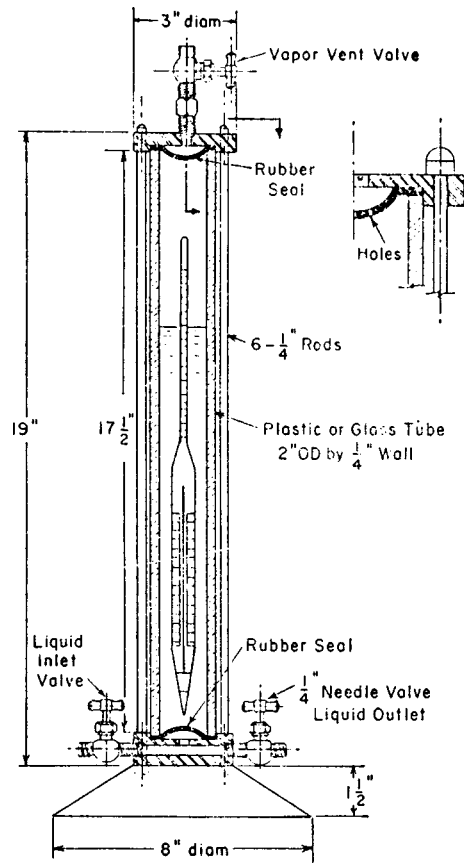

| Metric Equivalents | | |
|--------------------|--|-------|
| in. | | mm |
| 1/4 | | 6.35 |
| 1 1/2 | | 38.1 |
| 2 | | 50.8 |
| 3 | | 76.2 |
| 8 | | 203.2 |
| 17 1/2 | | 444.5 |
| 19 | | 482.6 |

FIG. X1.2 Pressure Hydrometer Cylinder Comparator

The American Society for Testing and Materials takes no position respecting the validity of any patent rights asserted in connection with any item mentioned in this standard. Users of this standard are expressly advised that determination of the validity of any such patent rights, and the risk of infringement of such rights, are entirely their own responsibility.

This standard is subject to revision at any time by the responsible technical committee and must be reviewed every five years and if not revised, either reapproved or withdrawn. Your comments are invited either for revision of this standard or for additional standards and should be addressed to ASTM Headquarters. Your comments will receive careful consideration at a meeting of the responsible technical committee, which you may attend. If you feel that your comments have not received a fair hearing you should make your views known to the ASTM Committee on Standards, 100 Barr Harbor Drive, West Conshohocken, PA 19428.