



Standard Specification for Liquid-in-Glass ASTM Thermometers with Low-Hazard Precision Liquids¹

This standard is issued under the fixed designation E 2251; the number immediately following the designation indicates the year of original adoption or, in the case of revision, the year of last revision. A number in parentheses indicates the year of last reapproval. A superscript epsilon (ϵ) indicates an editorial change since the last revision or reapproval.

1. Scope

1.1 The purpose of this standard is to specify liquid-in-glass ASTM thermometers using low hazard thermometric liquids defined in this standard.

1.2 This standard specifies liquid-in-glass thermometers graduated in degrees Celsius or degrees Fahrenheit that are frequently identified and used in methods under the jurisdiction of the various technical committees within ASTM. The current approved thermometers are listed in Table 1.

1.3 The technical requirements for the thermometric liquids used in the thermometers in Table 1 are specified in Annex A1. Tests for conformity to the technical requirements are also found in Annex A1.

NOTE 1—It has been found by experience that ASTM Thermometers, although developed in general for specific tests, may also be found suitable for other applications, thus precluding the need for new thermometer specifications differing in only minor features. However, it is suggested that technical committees contact E20.05 before choosing a currently designated thermometer for a new method to be sure the thermometer will be suitable for the intended application.

1.4 For full rationale, see Appendix X1.

1.5 *This standard does not purport to address all of the safety concerns, if any, associated with its use. It is the responsibility of the user of this standard to establish appropriate safety and health practices and determine the applicability of regulatory requirements prior to use.*

2. Referenced Documents

2.1 ASTM Standards:

E 1 Specification for ASTM Thermometers

E 77 Test Method for Inspection and Verification of Thermometers

E 344 Terminology Relating to Thermometry and Hydrometry

E 563 Practice for Preparation and Use of an Ice-Point Bath as a Reference Temperature

3. Terminology

3.1 *Definitions*—The definitions given in Terminology E 344 apply.

3.2 Definitions of Terms Specific to This Standard:

3.2.1 *bulb length, n*—the distance from the bottom of the bulb to the junction of the bulb and the stem tubing.

3.2.2 *contraction chamber, n*—an enlargement of the capillary, located below the main scale or between the main scale and the auxiliary scale, that serves to reduce the scale length or to prevent contraction of all the liquid column into the bulb.

3.2.3 *diameter, n*—the largest outside dimension of the glass tubing as measured with a ring gage.

3.2.4 *expansion chamber, n*—an enlargement at the top of the capillary to provide protection against breakage caused by excessive gas pressure.

3.2.5 *faden thermometer, n*—a thermometer with a long, thin bulb used to determine emergent stem temperatures.

3.2.6 *interval error, n*—the deviation of the nominal value of a temperature interval from its true value; either for the total range (total interval) or for a part of the range (partial interval).

3.2.7 *low-hazard liquid, n*—a liquid that is biodegradable, non-hazardous and considered non-toxic in thermometer quantities.

NOTE 2—It is the responsibility of the manufacturer to determine the suitability of a liquid for this standard. In marking the thermometer with the ASTM designation the manufacturer is confirming that the liquid in the thermometer is non-hazardous as defined by current OSHA (Occupational Safety and Health Administration) standards and non-toxic in thermometer quantities per current definitions of the United States Environmental Protection Agency.

3.2.8 *thermometric liquid, n*—the liquid in a liquid-in-glass thermometer that indicates the value of temperature.

3.2.9 *top of the thermometer, n*—the top of the finished instrument.

3.2.10 *total length, n*—the distance from the bottom of the bulb to the top of the finished thermometer, including any special finish at the top.

¹ This specification is under the jurisdiction of ASTM Committee E20 on Temperature Measurement and is the direct responsibility of Subcommittee E20.05 on Liquid-in-Glass Thermometers and Hydrometers.

Current edition approved Nov. 1, 2003. Published November 2003. Originally approved in 2003. Last previous edition approved in 2003 as E 2251–03.

3.3 Other terms may be found in the Terminology sections of Specification E 1 and Test Method E 77.

4. Specifications

4.1 The individual thermometers shall conform to the detailed specifications given in Table 1, the general requirements specified in Sections 5-15, and Annex A1 and Annex A2.

NOTE 3—Thermometers manufactured to previous revisions of this standard shall retain the same ASTM status as those meeting current specifications.

NOTE 4—The encapsulation (jacketing) of the glass of liquid-in-glass thermometers with polyfluorinated hydrocarbons will change their performance and physical characteristics, including, but not limited to, response time, accuracy, and physical dimensions. Therefore, under no circumstances should an encapsulated or otherwise modified ASTM thermometer be used in performing tests that specify the use of an ASTM thermometer.

5. Type

5.1 Each thermometer in Table 1 shall be of the liquid-in-glass type filled with a low hazard thermometric liquid that meets the specifications in Annex A1. The gas filling above the liquid shall be nitrogen or other suitable inert gas. The filling gas shall be chosen to have very low solubility in the thermometric fluid.

6. Stem

6.1 *Stem*—The stem shall be made of suitable thermometer tubing and shall have a plain front and enamel back.

6.2 *Top Finish*—The top of all thermometers specified in Table 1 shall have a plain rounded finish, except the following, which shall have the top finish indicated below:

6.2.1 *Special Finish:*

6.2.1.1 Any finish suitable for assembly in a standard 304.8-mm (12-in.) non-sparking metal armor with open face; in a cup case assembly; or in a flushing case assembly as defined in standards the thermometers are used in:

Thermometers S59C, S59F

7. Bulb

7.1 The bulb shall be made of glass having a viscosity of at least $10^{14.6}$ poises at 490°C (914°F) and at least $10^{13.4}$ poises at 520°C (968°F).

NOTE 5—Thermometers made with bulb glasses having properties close to these minimum requirements should not be subjected to temperatures above 405°C (760°F) or be continuously exposed to temperatures above 370°C (700°F).

8. Capillary Clearances

8.1 The following distances between graduations and the bulb, and between graduations and enlargements in the capillary, are minimum limits acceptable for thermometers in this standard.

NOTE 6—In order for a thermometer to be usable over its entire graduated range, graduation marks must not be placed too close to any enlargement in the capillary. Insufficient immersion of the thermometric liquid in the main bulb or capillary enlargement, graduation marks placed over parts of the capillary that have been changed by manufacturing operations, or graduations so close to the top of the thermometer that excessive gas pressure results when the thermometric liquid is raised to this level, may lead to appreciable errors.

8.1.1 A 13-mm length of unchanged capillary between the bulb and the immersion line or lowest graduation, if the graduation is not above 100°C (212°F); a 30-mm length if the graduation is above 100°C (212°F).

8.1.2 A 5-mm length of unchanged capillary between an enlargement and the graduation next below, except at the top of the thermometer.

8.1.3 A 10-mm length of unchanged capillary between an enlargement, other than the bulb, and the immersion line or the graduation next above, if the graduation is not above 100°C (212°F); a 30-mm length if the graduation is above 100°C (212°F).

8.1.4 A 10-mm length of unchanged capillary above the highest graduation, if there is an expansion chamber at the top of the thermometer; a 30-mm length if there is no expansion chamber. For the purposes of this requirement, “an expansion chamber” is interpreted as an enlargement at the top end of the capillary bore that shall have a capacity equivalent to not less than 20 mm of unchanged capillary.

8.2 Due to a change in the methods used for scale placement, it is possible to manufacture thermometers that comply with the specifications given in Table 1, but not meet the requirements for capillary clearances given above. In any case, the distances given in this section are the governing factor. Under no circumstances shall the scales on thermometers be placed closer than these minimum distances.

9. Graduations and Incriptions

9.1 All graduation lines, figures, and letters shall be clearly defined, suitably colored, and permanent. The width and the sharpness of the graduation lines shall be designed in accordance with necessary space between the graduations and the desired accuracy of interpolation. The middle of the graduation line shall be accurately determinable.

9.1.1 A suitably etched thermometer with the etched lines and figures filled with a suitable colorant shall be considered permanently marked provided it passes the test for permanency of pigment in Test Method E 77.

9.2 *Graduation Lines*—All graduation lines shall be straight, of uniform width, and perpendicular to the axis of the thermometer. The width of the graduation lines shall be as follows:

9.2.1 *Group 1*—Maximum line width 0.10 mm; for thermometers that may read to fractions of a division, often with magnifying aids:

Thermometers S56C, S56F, S62C, S62F, S63C, S63F, S64C, S64F, S65C, S65F, S66C, S66F, S67C, S67F, S91C, S116C, S117C, S120C

9.2.2 *Group 2*—Maximum line width 0.15 mm; for thermometers that may be read to the nearest half division or where the congestion of scale dictates the use of a scale to moderate fineness:

Thermometers S12C, S12F

9.2.3 *Group 3*—Maximum line width 0.20 mm; for thermometers with more open scales, usually read to the nearest division, often times under adverse conditions where a bold graduation is therefore desired:

Thermometers S59C, S59F

9.3 *Immersion Line*—On partial immersion thermometers an immersion line shall be permanently marked on the front of the thermometer at the distance above the bottom of the bulb as specified in Table 1 within a tolerance of ± 0.5 mm. The immersion inscription shall be written in capital letters and abbreviated (for example, 76 mm immersion shall be written 76 MM IMM.)

9.4 *Terminal Numbers*—The terminal number shall be in full when there are one or more numbered graduations between it and the next full number. This rule need not necessarily be followed for:

9.4.1 *Precision Thermometers:*

S65F, S66F, S67C, and S67F

9.5 *Scale Below Zero*—When a scale extends both above and below 0°C or 0°F, the two parts of the scale shall be differentiated by some means. Examples of suitable means are:

9.5.1 Different colorants for the graduations for the two parts of the scale,

9.5.2 Different style of numerical characters for the two parts of the scale, and

9.5.3 Use of minus signs before appropriate numbers below 0°C or 0°F.

10. Special Inscription

10.1 The special inscription specified in Table 1 shall be marked on the thermometer in capital letters and Arabic numbers without the use of periods. Include year of current revision in the ASTM designation (for example ASTM S56C-03).

10.1.1 Each thermometer shall be permanently marked with a unique serial number and the manufacturer's tradename or mark.

10.1.2 Each thermometer shall have the average coefficient of thermal expansion of the liquid permanently marked.

10.1.3 When the length of the thermometer permits, the words "TOTAL IMMERSION" may also be inscribed on the back of thermometers calibrated for total immersion.

11. Permanency of Pigment

11.1 The test for permanency of pigment shall be performed on any convenient portion of the scale section of the thermom-

eter. The pigment shall not chalk, burn out, or loosen as a result of this test (see Test Method E 77).

12. Bulb Stability

12.1 No test for bulb stability is necessary for any thermometers currently in this standard. However, should there be in the future, the bulb stability test as found in Specification E 1 shall be used.

13. Scale Error

13.1 Thermometers shall be verified and calibrated at the temperatures specified in Table 4. Partial immersion thermometers shall be calibrated for the emergent stem temperatures specified in Table 4 using faden thermometers.

13.1.1 At the time of purchase, the scale errors must be within the maximum scale error found in Table 1. The indications of many high temperature and fractionally graduated thermometers may change with time and continued use, due to minute changes in bulb volume. Periodic verification of these thermometers either over the entire scale or reverification at the reference temperature (ice point or steam point), in accordance with procedures set forth in Test Method E 77, is recommended.

13.2 Due to the application requirements for range and construction of the following thermometer(s) do not have reference points such as ice and steam points:

S91C

14. Case and Instructions

14.1 Each thermometer shall be supplied in a suitable case on which shall appear the following marking (except when a transparent case is used): the letters "ASTM," the thermometer number (S59C, S59F, etc.), and the temperature range.

14.2 Each thermometer shall be supplied with suitable user instructions. See Appendix X2 for Sample User Instructions.

15. Methods of Verification and Calibration

15.1 Thermometers shall be verified and calibrated at the specified immersion in accordance with Test Method E 77. For partial immersion thermometers careful consideration to emergent stem temperatures shall be observed.

TABLE 1 Specification for E 2251 ASTM Thermometers

All dimensions are in millimetres.
See Table 4 for Verification and Calibration Temperatures.

All dimensions are in millimeters.
See Table 4 for Verification and Calibration Temperatures.

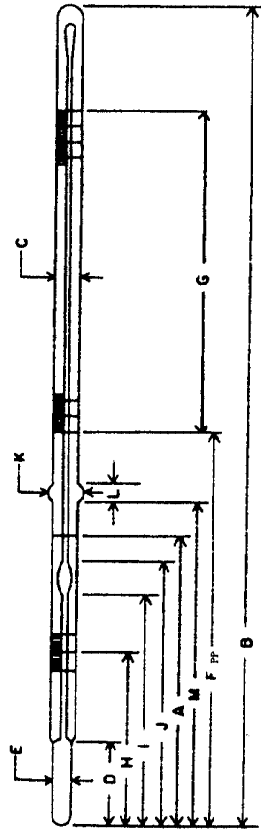

FIG A. General Reference Figure for Table 1
(Specific figures associated with individual thermometers are found at the end of Table 4)

Explanatory Notes for Table 1 (numbers correspond to those found in Table 1 of Specification E 1 whenever possible):

- ^A An expansion chamber is provided for relief of gas pressure to avoid distortion of the bulb at higher temperatures. It is not for the purpose of joining thermometric liquid separations and under no circumstances should the thermometer be heated above the highest temperature reading.
- ^M For kinematic viscosity thermometers, the ice-point reading shall be taken within 1 h after being at the test temperature for not less than 3 min. The ice-point reading shall be expressed to the nearest 0.01°C or 0.02°F and applied as explained in Test Method E 77, Section 13.
- ^O Capillary clearances must conform to Section 8.
- ^Y Over any interval of 2°C the change in calibration correction shall not exceed 0.02°C.
- ^Z Over any interval of 4°F the change in calibration correction shall not exceed 0.05°F.
- ^{AA} Special finish, see 6.2.1.
- ^{BB} The bulb diameter shall not be more than 0.5 mm greater than the stem.
- ^{FF} For Fahrenheit thermometers, dimension G (length of graduated portion) shall be measured as the length of graduated portion corresponding to the nominal Celsius range.
- ^{OO} Bulb length as necessary for the thermometric liquid and meeting capillary clearances found in Section 8.
- ^{PP} Distance "F" may be to top temperature for thermometers. See individual thermometer reference figure numbers.



TABLE 1 Continued

ASTM No.	S12C-03	S12F-03 ^{FF}	S56C-03	S56F-03 ^{FF}	S59C-03	S59F-03 ^{FF}
IP No.						
Name						
Reference Fig. No.						
Range	-20 to 102°C	-5 to 215°F	19 to 35°C	66 to 95°F	-18 to 82°C	0 to 180°F
For test at						
A Immersion, mm						
Graduations:						
Subdivisions	0.2°C	0.5°F	0.02°C	0.05°F	0.5°C	1°F
Long lines at each	1°C	1°F	0.1°C	0.1 and 0.5°F	1°C	5°F
Numbers at each	2°C	5°F	0.2°C	1°F	5°C	10°F
Scale error, max	0.15°C	0.25°F	0.10°C ^y	0.20°F ^z	0.3°C	0.5°F
Special inscription		ASTM		ASTM		ASTM
Expansion chamber:		S12C-03 or S12F-03		S56C-03 or S56F-03		S59C-03 or S59F-03
Permit heating to						
B Total length, mm	130°C ^A	266°F ^A	45°C ^A	113°F ^A	100°C ^A	212°F ^A
C Stem OD, mm	435 to 445		610 to 622		300 to 305	
D Bulb length, mm	6.0 to 8.0		7.0 to 8.0		6.0 to 7.0	
E Bulb OD, mm	∞		∞		∞	
Scale location:						
Bottom of bulb to line at	not > stem		^{BB}		not > stem	
F Distance, mm	102°C	215°F	35°C	95°F	82°C	180°F
G Length of graduated portion, mm		370 to 385		510 to 550		245 to 260
Ice-point scale:		305 to 350°		323 to 385°		165 to 195°
Range						
H Bottom of bulb to ice-point, mm						
Contraction chamber:						
I Distance to bottom, min, mm						
J Distance to top, max, mm						
K Stem enlargement:						
L OD, mm						
M Length, mm						
Distance to bottom, mm						

^A An expansion chamber is provided for relief of gas pressure to avoid distortion of the bulb at higher temperatures. It is not for the purpose of joining thermometric liquid separations and under no circumstances should the thermometer be heated above the highest temperature reading.

^C Capillary clearances shall conform to Section 8.

^y Over any interval of 2°C the change in calibration correction shall not exceed 0.02°C.

^z Over any interval of 4°F the change in calibration correction shall not exceed 0.05°F.

^{AA} Special finish, see 6.2.1.

^{BB} The bulb diameter shall not be more than 0.5 mm greater than the stem.

^{FF} For Fahrenheit thermometers, dimension G (length of graduated portion) shall be measured as the length of graduated portion corresponding to the nominal Celsius range.

[∞] Bulb length as necessary for the thermometric liquid and meeting capillary clearances found in Section 8.



TABLE 1 Continued

ASTM No.	S62C-03	S62F-03 ^{FF}	S63C-03	S63F-03 ^{FF}	S64C-03	S64F-03 ^{FF}
IP No.						
Name						
Reference Fig. No.						
Range	-38 to +2°C	-36 to 35°F	-8 to 32°C	18 to 89°F	25 to 55°C	77 to 131°F
For test at						
A Immersion, mm						
Graduations:						
Subdivisions	0.1°C	0.2°F	0.1°C	0.2°F	0.1°C	0.2°F
Long lines at each	0.5°C	1°F	0.5°C	1°F	0.5°C	1°F
Numbers at each	1°C	2°F	1°C	2°F	1°C	2°F
Scale error, max	0.1°C	0.2°F	0.1°C	0.2°F	0.1°C	0.2°F
Special inscription		ASTM		ASTM		ASTM
Expansion chamber:		S62C-03 or S62F-03		S63C-03 or S63F-03		S64C-03 or S64F-03
Permit heating to						
B Total length, mm	55°C ^A	131°F ^A	55°C ^A	131°F ^A	75°C ^A	167°F ^A
C Stem OD, mm						
D Bulb length, mm						
E Bulb OD, mm						
Scale location:						
Bottom of bulb to line at						
F Distance, mm	0°C	32°F	32°C	89°F	25°C	77°F
G Length of graduated portion, mm						
Ice-point scale:						
Range						
Bottom of bulb to ice-point, mm						
Contraction chamber:						
I Distance to bottom, min, mm						
J Distance to top, max, mm						
Stem enlargement:						
K OD, mm						
L Length, mm						
M Distance to bottom, mm						
Precision						
Precision 1						
Precision 2						
TOTAL						
TOTAL						

^A An expansion chamber is provided for relief of gas pressure to avoid distortion of the bulb at higher temperatures. It is not for the purpose of joining thermometric liquid separations and under no circumstances should the thermometer be heated above the highest temperature reading.

^C Capillary clearances shall conform to Section 8.

^{FF} For Fahrenheit thermometers, dimension G (length of graduated portion) shall be measured as the length of graduated portion corresponding to the nominal Celsius range.

^{oo} Bulb length as necessary for the thermometric liquid and meeting capillary clearances found in Section 8.



TABLE 1 Continued

ASTM No.	S66C-03	S65F-03 ^{FF}	S66C-03	S66F-03 ^{FF}	S67C-03	S67F-03 ^{FF}
IP No.						
Name						
Reference Fig. No.						
Range	50 to 80°C	122 to 176°F	75 to 105°C	167 to 221°F	95 to 155°C	203 to 311°F
For test at						
A Immersion, mm						
Graduations:						
Subdivisions	0.1°C	0.2°F	0.1°C	0.2°F	0.2°C	0.5°F
Long lines at each	0.5°C	1°F	0.5°C	1°F	1°C	1°F
Numbers at each	1°C	2°F	1°C	2°F	2°C	5°F
Scale error, max	0.1°C	0.2°F	0.1°C	0.2°F	0.2°C	0.5°F
Special inscription		ASTM		ASTM		ASTM
Expansion chamber:		S66C-03 or S65F-03		S66C-03 or S66F-03		S67C-03 or S67F-03
Permit heating to						
B Total length, mm	100°C ^A	212°F ^A	125°C ^A	257°F ^A	180°C ^A	355°F ^A
C Stem OD, mm	401 to 411	401 to 411	401 to 411	401 to 411	401 to 411	401 to 411
D Bulb length, mm	7.0 to 8.0	7.0 to 8.0	7.0 to 8.0	7.0 to 8.0	7.0 to 8.0	7.0 to 8.0
E Bulb OD, mm	∞	∞	∞	∞	∞	∞
Scale location:		Not > stem		not > stem		not > stem
Bottom of bulb to line at						
F Distance, mm	50°C	122°F	75°C	167°F	95°C	203°F
G Length of graduated portion, mm						
Ice-point scale:						
Range	-0.5 to 0.5°C ^O	31 to 33°F ^O	-0.5 to 0.5°C ^O	31 to 33°F ^O	-1 to +1°C ^O	30 to 34°F ^O
H Bottom of bulb to ice-point, mm						
Contraction chamber:						
I Distance to bottom, min, mm		∞		∞		∞
J Distance to top, max, mm		102		102		87
K Stem enlargement:						
L OD, mm						
M Length, mm						
N Distance to bottom, mm						

^A An expansion chamber is provided for relief of gas pressure to avoid distortion of the bulb at higher temperatures. It is not for the purpose of joining thermometric liquid separations and under no circumstances should the thermometer be heated above the highest temperature reading.

^O Capillary clearances shall conform to Section 8.

^{FF} For Fahrenheit thermometers, dimension G (length of graduated portion) shall be measured as the length of graduated portion corresponding to the nominal Celsius range.

[∞] Bulb length as necessary for the thermometric liquid and meeting capillary clearances found in Section 8.

TABLE 1 Continued

ASTM No.	S91C-03	S116C-03	S117C-03	S120C-03
IP No.				
Name	Solidification Point	Bomb Calorimeter	Bomb Calorimeter	Kinematic Viscosity ^M
Reference Fig. No.	3	4 and 5	4 and 5	1
Range	20 to 50°C	18.9 to 25.1°C	23.9 to 30.1°C	38.6 to 41.4°C
For test at				40°C
A	76 MM	TOTAL	TOTAL	TOTAL
Immerision, mm				
Graduations:	0.1°C	0.01°C	0.01°C	0.05°C
Subdivisions	0.5°C	0.05°C	0.05°C	0.1 and 0.5°C
Long lines at each	1°C	0.1°C	0.1°C	1°C
Numbers at each	0.1°C	0.1°C ^{JJ}	0.1°C ^{JJ}	0.1°C
Scale error, max	ASTM	ASTM	ASTM	ASTM
Special inscription	S91C-03	S116C-03	S117C-03	S120-03
	76 MM IMM			
Expansion chamber:				
Permit heating to	70°C ^A	35°C ^A	40°C ^A	60°C ^A
B Total length, mm	390 to 400	615 to 625	615 to 625	300 to 310
C Stem OD, mm	6.0 to 7.0	7.0 to 8.2 ^{KK}	7.0 to 8.2 ^{KK}	6.0 to 8.0
D Bulb length, mm	OO	OO, ^{KK}	OO, ^{KK}	OO
E Bulb OD, mm	not < 5.0 and not > stem	^{BB}	^{BB}	not > stem
Scale location:				
Bottom of bulb to line at	50°C	19°C	24°C	38.6°C
F Distance, mm	315 to 335	220 to 240	220 to 240	140 to 210
G Length of graduated portion, mm	185 to 219 ^O	300 to 350 ^O	300 to 350 ^O	40 to 90 ^O
Ice-point scale:				
Range				-0.3 to +0.3°C ^O
H Bottom of bulb to ice-point, mm				
Contraction chamber:				
I Distance to bottom, min, mm	O	O	O	100
J Distance to top, max, mm	63	110	110	130
K Stem enlargement:				
OD, mm				
L Length, mm				
M Distance to bottom, mm				

^A An expansion chamber is provided for relief of gas pressure to avoid distortion of the bulb at higher temperatures. It is not for the purpose of joining thermometric liquid separations and under no circumstances should the thermometer be heated above the highest temperature reading.

^M For kinematic viscosity thermometers, the ice-point reading shall be taken within 1 h after being at the test temperature for not less than 3 min. The ice-point reading shall be expressed to the nearest 0.01°C or 0.02°F and applied as explained in Test Method E 77, Section 13.

^O Capillary clearances shall conform to Section 8.

^{BB} The bulb diameter shall not be more than 0.5 mm greater than the stem.

^{JJ} Over any interval of 1°C the change in correction shall not exceed 0.01°C.

^{KK} The capillary bore shall be large enough in relation to the bulb to ensure that (without tapping) jumping of the meniscus does not exceed one-half of the smallest scale division, when the temperature is rising at a uniform rate not exceeding 0.05°C/min.

^{OO} Bulb length as necessary for the thermometric liquid and meeting capillary clearances found in Section 8.

TABLE 2 E 2251 ASTM Thermometers Listed Alphabetically According to Application

NOTE 1—The specifications appear in numeric sequence in this standard.

Thermometer Name	Thermometer No.		Thermometer Name	Thermometer No.	
	°C	°F		°C	°F
Bomb calorimeter	S56C	S56F	Precision	S63C	S63F
Bomb calorimeter	S116C		Precision	S64C	S64F
Bomb calorimeter	S117C		Precision	S65C	S65F
Density-Wide Range	S12C	S12F	Precision	S67C	S67F
Kinematic Viscosity	S120C	...	Solidification point	S91C	...
Precision	S62C	S62F	Tank	S59C	S59F

TABLE 3 List of ASTM Low-Hazard Thermometers by Temperature Range

Celsius Range	Immersion, mm	Scale Error, max	ASTM Thermometer Number	Fahrenheit Range	Immersion, mm	Scale Error, max	ASTM Thermometer Number
Graduated in 0.01°C							
18.9 to 25.1°C	total	0.1	S116C				
23.9 to 30.1°C	total	0.1	S117C				
Graduated in 0.02°C				Graduated in 0.05°F			
19 to 35°C	total	0.1	S56C	66 to 95°F	total	0.2	S56F
Graduated in 0.05°C				Graduated in 0.1°F			
38.6 to 41.4°C	total	0.1	S120C
Graduated in 0.1°C				Graduated in 0.2°F			
-38 to +2°C	total	0.1	S62C	-36 to +35°F	total	0.2	S62F
-8 to +32°C	total	0.1	S63C	18 to 89°F	total	0.2	S63F
20 to 50°C	76	0.1	S91C
25 to 55°C	total	0.1	S64C	77 to 131°F	total	0.2	S64F
50 to 80°C	total	0.1	S65C	122 to 176°F	total	0.2	S65F
75 to 105°C	total	0.1	S66C	167 to 221°F	total	0.2	S66F
Graduated in 0.2°C				Graduated in 0.5°F			
-20 to 102°C	total	0.15	S12C	-5 to 215°F	total	0.25	S12F
95 to 155°C	total	0.2	S67C	203 to 311°F	total	0.5	S67F
Graduated in 0.5°C				Graduated in 1°F			
-18 to +82°C	total	0.3	S59C	0 to 180°F	total	0.5	S59F

TABLE 4 Verification and Calibration Temperatures^A

Temperature	Av Temp. of Emergent Thermometric Liquid Column	Temperature	Av Temp. of Emergent Thermometric Liquid Column	Temperature	Av Temp. of Emergent Thermometric Liquid Column	Temperature	Av Temp. of Emergent Thermometric Liquid Column
Thermometer S12C –20 to 102°C		Thermometer S12F –5 to 215°F		Thermometer S56C 19 to 35°C		Thermometer S56F 66 to 95°F	
–20°C		–5°F		every 2° from 19°C		every 4° from 65°F and including 95°F	
–10°C		15°F					
0°C		32°F					
10°C		60°F					
20°C		85°F					
30°C		110°F					
40°C		135°F					
50°C		160°F					
60°C		185°F					
70°C		210°F					
80°C							
90°C							
100°C							
Thermometer S59C –18 to +82°C		Thermometer S59F 0 to 180°F		Thermometer S62C –38 to +2°C		Thermometer S62F –36 to +35°F	
0°C		32°F		–37°C		–35°F	
25°C		80°F		–30°C		–15°F	
55°C		130°F		–20°C		0°F	
80°C		180°F		–10°C		15°F	
				0°C		32°F	
Thermometer S63C –8 to +32°C		Thermometer S63F 18 to 89°F		Thermometer S64C 25 to 55°C		Thermometer S64F 77 to 131°F	
–7°C		20°F		0°C		32°F	
0°C		32°F		25°C		80°F	
10°C		50°F		35°C		95°F	
20°C		70°F		45°C		115°F	
30°C		88°F		55°C		130°F	
Thermometer S65C 50 to 80°C		Thermometer S65F 122 to 176°F		Thermometer S66C 75 to 105°C		Thermometer S66F 167 to 221°F	
0°C		32°F		0°C		32°F	
50°C		125°F		75°C		168°F	
60°C		145°F		85°C		185°F	
70°C		160°F		95°C		200°F	
80°C		175°F		105°C		220°F	
Thermometer S67C 95 to 155°C		Thermometer S67F 203 to 311°F		Thermometer S91C 20 to 50°C		Thermometer S116C 18.9 to 25.1°C	
0°C		32°F		20°C	25°C	every 1°C from 19°C	
100°C		205°F		30°C	25°C		
110°C		240°F		40°C	25°C		
130°C		275°F		50°C	25°C		
150°C		310°F					
Thermometer S117C 23.9 to 30.1°C		Thermometer S120C 38.6 to 41.4°C					
every 1°C from 24°C		0°C					
		40°C					
		41°C					

^A For verification and calibration of total immersion thermometers see Test Method E 77.

The emergent column temperatures are those attained when using the thermometers in the test equipment for which the thermometers were originally designed. In some cases these temperatures are markedly different from those realized during verification. Analysis of the factors affecting emergent column temperatures in use will provide the explanation for such apparent inconsistencies. See Annex A2 for information on using faden thermometers to evaluate emergent stem temperatures.

16. Keywords

16.1 bulb; liquid-in-glass thermometers; low-hazard liquid; standard specification; stem; temperature; thermometer

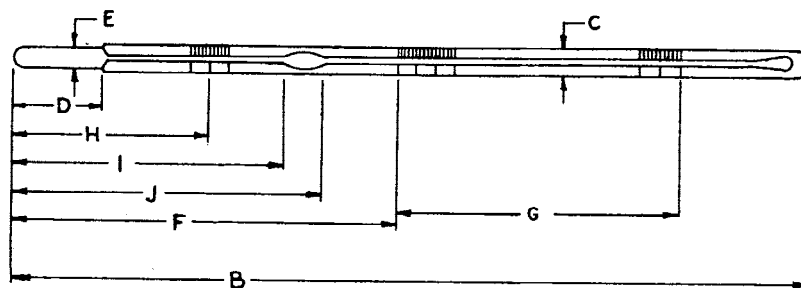

FIG. 1 Total Immersion Thermometer with Auxiliary Ice Point

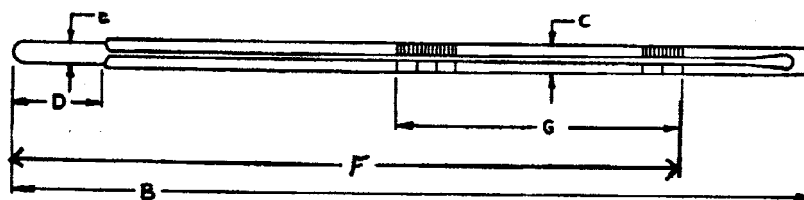

FIG. 2 Total Immersion Thermometer without Contraction Chamber

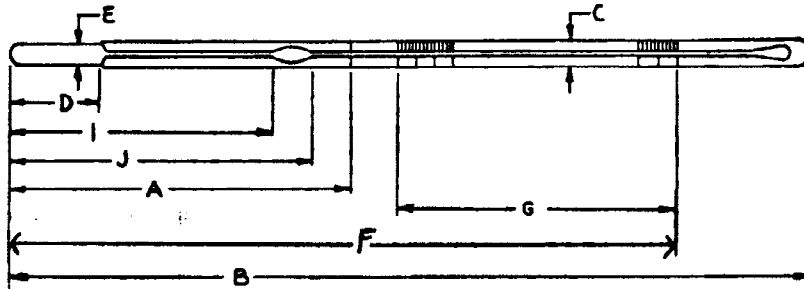

FIG. 3 Partial Immersion Thermometer with Contraction Chamber

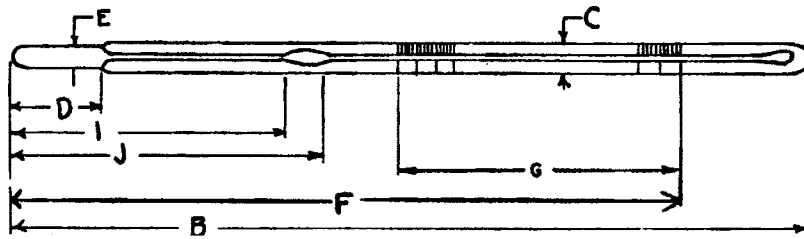

FIG. 4 Total Immersion Thermometer with Contraction Chamber

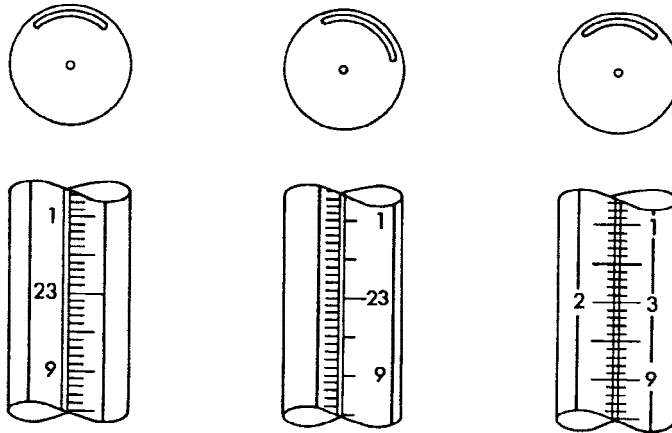

FIG. 5 Schemes for Graduation and Figuring S56C and S56F

ANNEXES

(Mandatory Information)

A1. TECHNICAL REQUIREMENTS FOR THE THERMOMETRIC LIQUID

A1.1 Purpose

A1.1.1 This annex shall be used by liquid-in-glass thermometer manufacturers to determine the suitability of a proposed liquid to be used in manufacturing the thermometers in this standard. The tests in this annex shall be successfully accomplished, prior to marketing thermometers using the proposed liquid.

A1.1.2 After completing the tests below, the manufacturer will know the highest temperature the tested liquid shall be used at. The manufacturer will then be able to construct thermometers in this standard with top ranges at or below the highest temperature of the test.

A1.2 Behavior of Liquid and Response Time

A1.2.1 Under 5× magnification, the liquid shall show either no meniscus or a positive meniscus. Under no circumstances shall it show a negative meniscus.

A1.2.2 The liquid column must be able to ascend or descend upon change in temperature so that the top of the liquid column reaches its final position within 3 minutes of attaining temperature to be measured within the limits described in the balance of this annex.

A1.2.3 Liquid shall be able to descend from a higher temperature to a lower temperature at a minimum rate of 20°C per minute without separation of the liquid column.

A1.2.4 Liquid shall be able to descend through a contraction chamber at a rate of 20°C per minute and have a repeatable ice point reading within 3 min of attaining the ice point temperature in an ice point bath, within the limits described in the balance of this annex.

A1.3 Stability of the Thermometric Liquid (Decomposition)

The liquid shall be considered stable up to the highest temperature tested if it passes the following set of tests:

A1.3.1 In a comparator bath, bring a minimum of 5 total immersion thermometers to the highest temperature the liquid is expected to perform. Leave the thermometers in the bath at that temperature for a minimum of 6 h per day for 20 days (minimum of 5 days per week). If the liquid will be dyed, it is best to manufacture test thermometers with undyed liquids.

A1.3.1.1 Before removing the thermometers from the comparator each day, check for distillation above the liquid column using 5× magnification. If the liquid distills, thermometers fail the test and the liquid is not considered suitable for thermometers in this standard at the temperature tested. The manufacturer may begin the tests again at a lower temperature.

A1.3.1.2 When thermometers have cooled, check for changes in color or hue of the undyed liquid. If the liquid changes in color or hue, thermometers fail the test and the liquid is not considered suitable for thermometers in this standard.

A1.3.1.3 After the twentieth day, wait a minimum of 72 h and proceed with tests in A1.5.

A1.3.1.4 If thermometers do not repeat per A1.5, liquid is not considered suitable for thermometers in this standard at the temperature tested. The manufacturer may begin the tests again at a lower temperature.

A1.3.1.5 If thermometers repeat per A1.5, proceed to A1.3.2.

A1.3.2 In a comparator bath, bring the same thermometers tested in A1.3.1 back to the highest temperature of the liquid at which the liquid passed all of the tests in A1.3.1. Leave the thermometers in the bath at that temperature for a minimum of 6 h per day for 5 days.

A1.3.2.1 Repeat A1.3.1.1.

A1.3.2.2 Repeat A1.3.1.2.

A1.3.2.3 After the fifth day, wait a minimum of 72 h and proceed with tests in A1.5.

A1.3.2.4 If thermometers do not repeat per A1.5, liquid is not considered suitable for thermometers in this standard at the temperature tested. The manufacturer may begin the tests again at a lower temperature.

A1.3.2.5 If thermometers repeat per A1.5, using the same test thermometers, repeat this section of tests (A1.3) a minimum ten test cycles. (If after ten test cycles the thermometers still pass the tests in A1.5, the liquids tested shall be considered stable, up to the highest temperatures successfully tested, for use in thermometers in this standard. If the liquids are to be dyed, the dye must also pass the permanency of dye tests in A1.4.)

A1.4 Permanency of Dye (as Applicable)

The dye shall be considered stable up to the highest temperature tested if it passes the following test.

A1.4.1 In a comparator bath, bring a minimum of 5 total immersion thermometers to the highest temperature at which the liquid passed all of the tests in A1.3.1. Leave the thermometers in the bath at that temperature for a minimum of 6 h per day for 20 days (minimum of 5 days per week). Keep at least one thermometer out of the baths as a color control.

A1.4.2 Allow to cool each day and compare the test thermometers with the control thermometer. Visually check for the following parameters:

A1.4.2.1 Dye shall have no solids floating in liquid.

A1.4.2.2 Dye shall not lighten or disappear.

A1.4.2.3 Dye shall have no appreciable change of color.

A1.4.2.4 Dye shall not separate from the liquid.

A1.4.3 If after the twentieth day the dye has not visually changed per the above parameters, repeat the test for 5 concurrent days for ten test cycles.

A1.4.4 If after ten test cycles the thermometers still pass the tests in A1.4.2, the dye shall be considered permanent for the liquids tested up to the highest temperature tested.

A1.5 Repeatability Requirements

A1.5.1 Main Scale of test thermometer.

A1.5.1.1 In a comparator bath, bring a test thermometer and a calibrated mercury-in-glass standard thermometer with the same scale divisions as the test thermometer to the highest temperature inscribed on the test thermometer. Leave the thermometers in the comparator for a minimum of 3 min.

NOTE A1.1—The manufacturer may wish to have another thermometer of suitable range and accuracy in the comparator with the test thermometer and calibrated mercury-in-glass thermometer. This thermometer may be used to measure the actual temperature of the comparator. However, since the test is being accomplished with an expanded bulb test thermometer, the absolute temperature of the comparator is less important than the comparison of performance against a mercury-in-glass thermometer of known accuracy. The results of the test shall be determined by the comparison of test thermometer and calibrated standard thermometer.

A1.5.1.2 Bring the temperature of the thermometers down at a rate no more than 20°C per minute and no less than 10°C per minute to exactly ten lines below the maximum temperature of the test thermometer (this is temperature A). The comparator shall be set with the test thermometer. After 3 min,

read both your calibrated mercury-in-glass standard thermometer and the test thermometer. Record the results for measurements A1. The difference between the readings of the test thermometer and the corrected readings of the standard thermometer shall be within the tolerance of the test thermometer at that temperature.

A1.5.1.3 Immediately bring the temperature of the thermometers down at a rate no more than 20°C per minute and no less than 10°C per minute to exactly 100 lines below temperature A on the test thermometer. This is temperature B. The comparator shall be set with the test thermometer. After 3 min, read both your calibrated mercury-in-glass standard thermometer and the test thermometer. Record the results for measurement B1. The difference between the readings of the test thermometer and the corrected readings of the standard thermometer shall be within the tolerance of the test thermometer at that temperature.

A1.5.1.4 Immediately repeat steps A1.5.1.1 through A1.5.1.3. These readings shall be considered measurements A2 and B2.

A1.5.1.5 The difference between the corrected readings on the calibrated standard between measurement A1 and A2 shall be no more than $\frac{1}{10}$ th of the smallest scale division. Since the bath is being set to the lines on the test thermometer, there should be no difference in the readings of the test thermometer between measurement A1 and A2. The absolute temperature of the comparator need not be known.

A1.5.1.6 The difference between the corrected readings on the calibrated standard between measurement B1 and B2 shall be no more than $\frac{1}{10}$ th of the smallest scale division. Since the bath is being set to the lines on the test thermometer, there should be no difference in the readings of the test thermometer between measurement B1 and B2. The absolute temperature of the comparator need not be known.

NOTE A1.2—If the test thermometer does not have 100 lines in its scale, then the test shall be done using temperature A as ten lines below the top temperature on the scale and B 10 lines above the lowest temperature on the scale.

A2. USE OF FADEN THERMOMETERS WITH EMERGENT STEM TEMPERATURE CORRECTIONS²

A2.1 Specification for Faden Thermometer

A2.1.1 A faden thermometer gives a convenient and accurate measurement of the emergent stem temperature of a partial immersion thermometer or a total immersion thermometer immersed as a partial immersion thermometer. Faden thermometers have long bulbs measuring between 5 and 20 cm, with wall thicknesses and bore sizes nearly the same as the stem of an ordinary thermometer. The bulb length is selected to approximate that of the emergent stem whose temperature is to be measured. The stem of the faden thermometer has a finer capillary than its bulb and for this standard (E 2251) shall be

A1.5.2 Auxiliary Ice Point Scale of test thermometer.

A1.5.2.1 Prepare an ice point bath per Practice E 563.

A1.5.2.2 In a comparator bath, bring a test thermometer to the highest temperature inscribed on the test thermometer. Leave the thermometers in the comparator for a minimum of 3 min.

A1.5.2.3 Bring the temperature of the thermometer down at a rate no more than 20°C per minute and no less than 10°C per minute through a contraction chamber to an auxiliary ice point graduation. After 3 min, read the thermometer. Record the results for measurement A1.

A1.5.2.4 Remove the thermometer from the ice point bath and permit it to naturally warm to room temperature. Wait a minimum of 3 min and maximum of 5 min at that temperature.

A1.5.2.5 Immediately repeat step A1.5.2.3.

A1.5.2.6 The difference between the two ice point readings shall be no more than $\frac{1}{10}$ th of the smallest scale division of the test thermometer.

A1.6 Reproducibility Requirements

Repeat tests in A1.5 for ten test cycles as described in A1.3.

A1.6.1 Compare the ten results of A1.5.1.5. All tests shall agree within $\frac{3}{10}$ ths of the smallest scale division of the test thermometer (after correction for changes at the ice point).

A1.6.2 Compare the ten results of A1.5.1.6. All tests shall agree within $\frac{3}{10}$ ths of the smallest scale division of the test thermometer (after correction for changes at the ice point).

A1.7 Coefficient of Thermal Expansion

A1.7.1 The coefficient of Thermal Expansion shall be calculated for the liquid. The calculated value shall be adequate to be used in the stem temperature correction formulae found in Annex A2 and must be known and reported as an inscription on the back of the thermometer (see 10.1.2).

A1.7.2 Only liquids meeting all of the requirements and tests of this annex and the definition of low-hazard liquid in 3.2.7 shall be considered suitable as thermometric liquids in this standard. Manufacturers shall retain testing records for each unique liquid or application.

graduated in 0.5°C divisions or 1°F divisions. The reading of the faden thermometer or thermometers will indicate the mean temperature value of the area surrounding the bulb, which is also the mean temperature value of the adjacent portion of the thermometer stem.

NOTE A2.1—Auxiliary thermometers may be used if faden thermometers are not available. However, they may not be able to approximate the emergent stem temperatures to the precision necessary for some test methods and should never be substituted during manufacture or calibration.

A2.2 Use with Partial Immersion Thermometers

A2.2.1 A faden thermometer, or combination of faden thermometers, shall be used to measure the mean emergent stem temperature from the immersion line to the top of the liquid column of a partial immersion thermometer. Be aware

² Wise, J. NIST Publication 250-23. Liquid-in-glass thermometer calibration service, 1988:82. U.S. Dept. of Commerce, NIST, Gaithersburg, MD.

that the immersion line may be under a plate or holder in a comparator. The faden thermometer must measure from the immersion line, not the top of the plate or holder, but should not be immersed in the liquid being measured.

A2.2.1.1 If a combination of faden thermometers is used to approximate the average emergent stem temperature the following formula using the average of the readings (weighted by the length of the faden thermometer in millimeters) shall be used.

$$\text{Emergent stem temperature} = [(\text{length of faden one} \cdot \text{reading faden one}) + (\text{length of faden two} \cdot \text{reading faden two})] / \text{length of emergent column}$$

For example, if two faden thermometers are used to measure a 314 mm emergent stem, and one faden has a 200 mm bulb length and the second faden has a 114 mm bulb length:

$$\text{Emergent stem temperature} = [(200 \cdot \text{reading faden one}) + (114 \cdot \text{reading faden two})] / 314$$

A2.2.1.2 Occasionally it may be necessary to use a faden thermometer that is longer than the emergent liquid column. When this is the case, a second faden thermometer of appropriate length shall be placed with the top of its bulb on a horizontal plane with the top of the bulb of the longer faden thermometer, and the bottom of the bulb adjacent to the top of the thermometric liquid column of the thermometer being measured. The stem temperature is then determined by subtracting the length of the second faden thermometer multiplied by the reading and dividing this value by the distance from the immersion line to the end of the thermometric liquid column of the thermometer being measured. For example, if two faden thermometers are used to measure a 150 mm emergent stem, and one faden has a 200mm bulb length and the second faden has a 50 mm bulb length, the following formula applies:

$$\text{Emergent stem temperature} = [(200 \cdot \text{reading faden one}) - (50 \cdot \text{reading faden two})] / 150$$

A2.2.2 All partial immersion ASTM thermometers show emergent stem temperature data in Table 4. All temperature calibrations for these thermometers shall be corrected for these temperatures, even if they seem artificially high or low.

A2.2.2.1 When correcting for differences in observed and specified stem temperatures during calibration, the following formula applies:

$$\text{Emergent stem temperature correction} = kn (tsp - tobs)$$

where:

- k = coefficient of thermal expansion for thermometric liquid in specified type of glass,
- n = magnitude of the temperature interval (in °C or °F) represented by the portion of the thermometer stem emergent from the bath, including the evaluated portion from the immersion line to the first graduation,
- tsp = emergent stem temperature specified in Table 4, and
- $tobs$ = emergent stem temperature found with faden thermometer(s).

A2.3 Use with Total Immersion Thermometers Being Used as Partial Immersion

A2.3.1 Whenever possible, total immersion ASTM thermometers should be calibrated and used at total immersion. If this is impossible, it is essential to measure the emergent stem temperature of that portion of the thermometer that is in the incorrect environment.

A2.3.1.1 Under no circumstances shall a total immersion thermometer be calibrated if the contraction chamber is out of the comparator bath or in the unknown region of the bath.

A2.3.1.2 Measure the emergent stem temperature using the faden thermometers described in A2.2.

A2.3.1.3 The formula is modified as follows:

$$\text{Emergent stem temperature correction} = kn (t1 - t)$$

where:

- k = coefficient of thermal expansion for thermometric liquid specified type of glass,
- n = number of degrees emergent from the bath (number of degrees between the top of the comparator bath liquid and the end of the thermometric liquid column),
- $t1$ = temperature being calibrated (bath temperature), and
- t = emergent stem temperature found with faden thermometer(s).

APPENDIXES

(Nonmandatory Information)

X1. RATIONALE

X1.1 History

X1.1.1 This standard was created to introduce and give specifications for liquid-in-glass thermometers using low-hazard precision thermometric liquid alternatives to the mercury, mercury thallium and toluene/organic filled (spirit) thermometers found in Specification E 1.

X1.1.2 The thermometers in this standard will perform to the specifications in Table 1. However, in some ways, they

perform differently than either mercury or spirit thermometers. Therefore, it was the decision of the task group governing this task in subcommittee E20.05 to create a new standard for these thermometers.

X1.1.3 The thermometers in this standard will meet the tolerances, repeatability and response times necessary for use in ASTM standards when used following the manufacturer's instructions, like those found in Appendix X2.

X1.2 Specification for Liquids

X1.2.1 Unlike Specification E 1, which specifies mercury, mercury-thallium or toluene (spirit), this standard does not require the use of any specific liquid. Instead, Annex A1 gives very specific tests a manufacturer's liquid must perform to. The liquid must also meet the definition of low-hazard liquid found in 3.2.7.

X1.3 ASTM Designation

X1.3.1 Thermometers in Table 1 that are direct substitutes for thermometers found in Specification E 1 will have the same

designation as its mercury, mercury-thallium or toluene (spirit) equivalent from Specification E 1, but with an "S" in front of the number.

X1.3.2 Thermometers in Table 1 that will be designed for this standard that do not have direct equivalents in Specification E 1 will begin with the number ASTM 301 (C or F as necessary).

X2. SAMPLE USER INSTRUCTIONS

INTRODUCTION

Each thermometer in this standard will come with a complete set of manufacturers instructions. The instructions below are guidelines for the instructions sheets.

X2.1 General Instructions for Use

X2.1.1 The low hazard precision thermometers in this specification react very quickly to changes in temperatures being measured. It is important that when running the liquid from a higher temperature to a lower temperature (in the down direction) the rate of descent does not surpass a rate greater than 20°C per minute. When going from a lower to a higher temperature there is no restriction on rate of rise. Once at the desired temperature, leave thermometer in medium being tested a minimum of three minutes before reading.

X2.2 Ice Point Readings

X2.2.1 Place the thermometer in a beaker of room temperature water. GRADUALLY add chopped ice to the water so that the liquid moves no faster than 20°C per minute. As the liquid approaches the ice point, place the thermometer directly into a prepared ice point bath. Allow the thermometer to remain in the ice bath three minutes before reading temperature.

X2.3 Rejoining Liquid Column

X2.3.1 All thermometers experience occasional separations, especially during transit or storage. In order to obtain true and accurate readings; follow the rejoining instructions below. These thermometers rejoin more like mercury thermometers than spirit thermometers. However, because the liquid is much lighter than mercury, some modifications in the technique are necessary.

X2.3.2 Rejoining separations in thermometers with two upper expansion chambers (low temperature thermometers). These low range thermometers are normally joined in one of the two upper chambers.

X2.3.2.1 If the separation is in the lower part of the scale, run the liquid down (no faster than 20°C per minute) using dry ice and alcohol. When all the liquid is in the bulb, tap the bulb gently so the separations rejoin. Allow the thermometer to stand at room temperature while the liquid rises. Do not touch

the bulb with your hand as this may cause the bulb to break. Allow the thermometer to reach room temperature before using.

X2.3.2.2 If the separation is below the lower expansion chamber above the scale, use a cup of warm water to force the liquid into the first chamber and gently tap the thermometer until the separations are joined. If the separation does not join easily in the chamber, gently tap the side of the thermometer near the chamber until the separated liquid is all on one side of the chamber. Then allow the balance of the liquid column to run further into the chamber and the liquids will rejoin. Allow the thermometer to reach room temperature before using.

X2.3.2.3 If the separation is between the two expansion chambers, dip the bulb into plain chopped ice until all the liquid is in the chamber. Gently tap the side of the thermometer near the chamber until the separated liquid is all on one side of the chamber. Slowly run the liquid in the bore into the chamber, tapping the bulb if needed to keep the liquid in the chamber at the side of the chamber. When both liquids meet, tap the thermometer gently until they join. Allow the thermometer to reach room temperature before using.

X2.3.2.4 If the separation is above the lower chamber or in the top chamber, prepare a cup of boiling water and a cup of warm water. Place the TOP of the thermometer (not the bulb end), including the top chamber, into boiling water for at least two minutes or until the liquid joins together into the bottom of the chamber. Now, place the thermometer's bulb into the warm water so the liquid in the bore rises and joins together with the separation in the top chamber. Gentle tapping may be required to rejoin. Maintain the thermometer in warm water and allow to cool naturally until it reaches the lower chamber temperature.

X2.3.3 Rejoining separations in thermometers with no contraction chamber. This type of thermometer may be joined in the bulb or the expansion chamber.

X2.3.3.1 If the separation is below the top line of the scale and below the expansion chamber. Slowly draw the liquid down into the bulb using a mixture of dry ice and a suitable

alcohol. Do not run the liquid down faster than 20° per minute. When all the liquid is in the bulb, tap the thermometer gently. This should cause the separation to join. Allow the thermometer to warm up naturally to room temperature before using. Do not touch the bulb with your hand as this could cause the bulb to break. Allow the thermometer to reach room temperature before using.

X2.3.3.2 If the separation is above the top line of the scale or in the expansion chamber, use the directions in X2.3.2.4 allowing the thermometer to cool naturally until it reaches room temperature.

X2.3.4 Rejoining separations in thermometers with contraction chambers or ice point chambers. This type of thermometer may be joined in the bulb and in the contraction chamber. It is only to be joined in the top chamber if the liquid is separated into the top chamber.

X2.3.4.1 If the separation is between the bulb and the contraction chamber or ice point chamber, slowly draw the liquid down into the bulb using a mixture of dry ice and alcohol. Do not run the liquid down faster than 20° per minute. When all the liquid is in the bulb, tap the thermometer gently. This should cause the separation to join. Allow the thermometer to warm up naturally to room temperature before using. Do not touch the bulb with your hand as this could cause the bulb to break. Allow the thermometer to reach room temperature before using.

X2.3.4.2 If the separation is above the contraction chamber or ice point chamber and below the top line of the scale, dip the bulb into plain chopped ice until all the liquid is in the chamber. Gently tap the side of the thermometer near the chamber until the separated liquid is all on one side of the chamber. Slowly run the liquid in the bore into the chamber, tapping the bulb if needed to keep the liquid in the chamber at the side of the chamber. When both liquids meet, tap the thermometer gently until they join. Allow the thermometer to reach room temperature before using.

X2.3.4.3 If the separation is above the top line of the scale or in the top chamber, use the directions in X2.3.2.4 allowing the thermometer to cool naturally until it reaches room temperature.

X2.4 Use of Faden Thermometers to Determine Emergent Stem Temperature Corrections

X2.4.1 It is important to be sure to know the emergent stem temperature of partial immersion thermometers or total immersion thermometers being used in a condition of partial immersion. When using a partial immersion thermometer, use it in conjunction with the information on emergent stem temperatures found in Table 4.

X2.4.2 Use with partial immersion thermometers.

X2.4.2.1 A faden thermometer, or combination of faden thermometers, shall be used to measure the mean emergent stem temperature from the immersion line to the top of the liquid column of a partial immersion thermometer. Be aware that the immersion line may be under a plate or holder. The faden thermometer must measure the temperature from the immersion line, not the top of the plate or the thermometer holder, and must not be immersed in the liquid being measured.

X2.4.2.1.1 If a combination of faden thermometers is used to approximate the average emergent stem temperature the following formula shall be used; the average of the readings (weighted by the length of the faden thermometer in millimeters) shall be used. For example, if two faden thermometers are used to measure a 314 mm emergent stem, and one faden has a 200 mm bulb length and the second faden has a 114 mm bulb length:

$$\text{Emergent stem temperature} = [(200 \cdot \text{reading faden one}) + (114 \cdot \text{reading faden two})]/314$$

X2.4.2.1.2 Occasionally it may be necessary to use a faden thermometer that is longer than the emergent liquid column. When this is the case, a second faden thermometer of appropriate length shall be placed with the top of its bulb on a horizontal plane with the top of the bulb of the longer faden thermometer, and the bottom of the bulb adjacent to the top of the thermometric liquid column of the thermometer being measured. The stem temperature is then determined by subtracting the length of the second faden thermometer multiplied by the reading and dividing this value by the distance from the immersion line to the end of the thermometric liquid column of the thermometer being measured. For example, if two faden thermometers are used to measure a 150 mm emergent stem, and one faden has a 200 mm bulb length and the second faden has a 50 mm bulb length, the following formula applies:

$$\text{Emergent stem temperature} = [(200 \cdot \text{reading faden one}) - (50 \cdot \text{reading faden two})]/150$$

X2.4.2.2 Table 4 shows emergent stem temperature data for all ASTM partial immersion thermometers. All temperature readings for these thermometers must be corrected for these temperatures, even if they seem artificially high or low.

X2.4.2.2.1 When correcting for differences in observed and specified stem temperatures during calibration, the following formula applies:

$$\text{Emergent stem temperature correction} = kn (tsp - tobs)$$

where:

- k = coefficient of thermal expansion for thermometric liquid specified type of glass,
- n = magnitude of the temperature interval (in °C or °F) represented by the portion of the thermometer stem emergent from the bath, including the evaluated portion from the immersion line to the first graduation,
- tsp = emergent stem temperature specified in Table 4, and
- $tobs$ = emergent stem temperature found with faden thermometer(s).

X2.4.3 Use of faden thermometers when total immersion thermometers are used as partial immersion.

X2.4.3.1 Whenever possible, total immersion ASTM thermometers should be used at total immersion. If this is impossible or if called for use as partial in a standard or test method, it is essential to measure the emergent stem temperature of that portion of the thermometer that is in the incorrect environment.

X2.4.3.1.1 Under no circumstances shall a total immersion thermometer be calibrated with the contraction chamber out of the comparator bath, out of instrument the thermometer is used in, or in an unknown region of the bath or instrument.

X2.4.3.1.2 Measure the emergent stem temperature using the faden thermometers described in X2.4.2.1.

X2.4.3.1.3 The formula is modified as follows:

$$\text{Emergent stem temperature correction} = kn (t_1 - t)$$

where:

k = coefficient of thermal expansion for thermometric liquid specified type of glass,

n = number of degrees emergent from the bath (number of degrees between the top of the comparator bath liquid and the end of the thermometric liquid column),

t_1 = temperature being calibrated (bath temperature), and

t = emergent stem temperature found with faden thermometer(s).

ASTM International takes no position respecting the validity of any patent rights asserted in connection with any item mentioned in this standard. Users of this standard are expressly advised that determination of the validity of any such patent rights, and the risk of infringement of such rights, are entirely their own responsibility.

This standard is subject to revision at any time by the responsible technical committee and must be reviewed every five years and if not revised, either reapproved or withdrawn. Your comments are invited either for revision of this standard or for additional standards and should be addressed to ASTM International Headquarters. Your comments will receive careful consideration at a meeting of the responsible technical committee, which you may attend. If you feel that your comments have not received a fair hearing you should make your views known to the ASTM Committee on Standards, at the address shown below.

This standard is copyrighted by ASTM International, 100 Barr Harbor Drive, PO Box C700, West Conshohocken, PA 19428-2959, United States. Individual reprints (single or multiple copies) of this standard may be obtained by contacting ASTM at the above address or at 610-832-9585 (phone), 610-832-9555 (fax), or service@astm.org (e-mail); or through the ASTM website (www.astm.org).