



Standard Test Methods for Testing Industrial Resistance Thermometers¹

This standard is issued under the fixed designation E 644; the number immediately following the designation indicates the year of original adoption or, in the case of revision, the year of last revision. A number in parentheses indicates the year of last reapproval. A superscript epsilon (ϵ) indicates an editorial change since the last revision or reapproval.

1. Scope

1.1 These test methods cover the principles, apparatus, and procedures for calibration and testing of industrial resistance thermometers.

1.2 These test methods cover the tests for insulation resistance, calibration, immersion error, pressure effects, thermal response time, vibration effect, mechanical shock, self-heating effect, stability, thermoelectric effect, humidity, thermal hysteresis and thermal shock.

1.3 These test methods are not necessarily intended for, recommended to be performed on, or appropriate for every type of thermometer. The expected repeatability and reproducibility of the results are tabulated in Appendix X4.

1.4 These test methods, when specified in a procurement document, shall govern the method of testing the resistance thermometer.

1.5 Thermometer performance specifications, acceptance limits, and sampling methods are not covered in these test methods; they should be specified separately in the procurement document.

1.6 *This standard does not purport to address all of the safety concerns, if any, associated with its use. It is the responsibility of the user of this standard to establish appropriate safety and health practices and determine the applicability of regulatory limitations prior to use.* Specific precautionary statements are given in 6.3.2, 6.3.5, and 8.1.

2. Referenced Documents

2.1 ASTM Standards:²

E 77 Test Method for the Inspection and Verification of Thermometers

E 230 Temperature-Electromotive Force (EMF) Tables for Standardized Thermocouples

E 344 Terminology Relating to Thermometry and Hydrometry

E 563 Practice for Preparation and Use of an Ice-Point Bath as a Reference Temperature³

E 1137 Specification Industrial Platinum Resistance Thermometers

E 1502 Guide for Use of Freezing-Point Cells for Reference Temperatures

E 1750 Guide for Use of Water Triple Point Cells

E 1751 Guide to Temperature Electromotive Force (EMF) Tables for Non-Letter Designated Thermocouple Combinations

2.2 Military Standard:

MIL-STD-202 Test Methods for Electronic and Electrical Component Parts⁴

3. Terminology

3.1 Definitions of Terms Specific to This Standard:

3.1.1 The definitions given in Terminology E 344 shall apply to these test methods.

3.1.2 *bath gradient error, n*—the error caused by temperature differences in the working space of the bath. (The bath or temperature equalizing blocks should be explored to determine the work areas in which the temperature gradients are insignificant.)

3.1.3 *calibration, n*—the determination of the indications of a thermometer with respect to temperatures established by a standard resulting in scale corrections to be applied when maximum accuracy is required.

3.1.4 *connecting wire error, n*—the error caused by uncompensated connecting wire resistance. (Although the connecting wire is part of the measurement circuit, most of it is not at the temperature that is being determined. Thermometers are available in two-, three-, and four-wire configurations. There is no satisfactory way to compensate for the wire resistance in the measurement with a two-wire thermometer although the wire resistance can be compensated for in three and four-wire thermometers.)

¹ These test methods are under the jurisdiction of ASTM Committee E20 on Temperature Measurement and are the direct responsibility of Subcommittee E20.03 on Resistance Thermometers.

Current edition approved May 1, 2004. Published May 2004. Originally approved in 1978. Last previous edition approved in 2002 as E 644 – 02.

² For referenced ASTM standards, visit the ASTM website, www.astm.org, or contact ASTM Customer Service at service@astm.org. For *Annual Book of ASTM Standards* volume information, refer to the standard's Document Summary page on the ASTM website.

³ Withdrawn.

⁴ Available from Superintendent of Documents, U.S. Government Printing Office, Washington, DC 20234.

3.1.5 *immersion error, n*—an error caused by the heat conduction or radiation, or both, between the resistance thermometer element and the environment external to the measurement system, because of insufficient immersion length and thermal contact of the thermometer with the medium under measurement.

3.1.6 *interchangeability, n*—the extent to which the thermometer matches a resistance-temperature relationship. (The verification of interchangeability can be accomplished only by calibration. The deviations at the temperature limits and the maximum deviation from the established resistance-temperature relationship shall be specified.)

3.1.7 *self-heating, n*—the increase in the temperature of the thermometer element caused by the electric power dissipated in the element, the magnitude depending upon the thermometer current and heat conduction from the thermometer element to the surrounding medium.

3.1.8 *self-heating error, n*—the error caused by variations from the calibration conditions in the self-heating of the thermometer element at a given current, arising from the variations in the heat conduction from the thermometer to the surrounding medium.

3.1.9 *thermoelectric effect error, n*—the error caused by a thermal emf in the measurement circuit as a result of dissimilar metals and temperature gradients in the circuit.

4. Significance and Use

4.1 These test methods provide uniform methods for testing industrial resistance thermometers so that a given tester may expect to obtain the same value of a test result from making successive measurements on the same test article within the limits of repeatability given in Appendix X4. Independent testers may also expect to obtain the same result from the testing of the same article within the limits of reproducibility given in Appendix X4.

4.2 These tests may be used to qualify platinum resistance thermometers for use in specific applications to meet a particular specification such as Specification E 1137, or to evaluate relative merits of equivalent test articles supplied by one or more manufacturers, or to determine the limits of the application of a particular design of thermometer.

4.3 The expected repeatability and reproducibility of selected test methods are included in Appendix X4.

4.4 Some non-destructive tests described in these test methods may be applied to thermometers that can be subsequently sold or used; other destructive tests may preclude the sale or use of the test article because of damage that the test may produce.

PROCEDURES

5. Insulation Resistance Test

5.1 *Scope*—The insulation resistance between the thermometer element with its connecting wires and its external shield, case or means for mounting, should be sufficient to prevent significant electrical shunting or ground loop current in the measurement circuit, or any circuit failure if the excitation source is grounded. This test assumes that the thermometer has a metallic or other electrically conductive sheath or housing.

The most probable factors that contribute to insulation failure are contamination, typically from moisture, and mechanical breakdown due to physical damage to the device. Most ceramic oxide insulation absorbs moisture. This moisture is expected to migrate inside the thermometer, depending upon the temperature condition of use, and to cause variations in the insulation resistance. Test conditions for insulation resistance should therefore approximate the most severe conditions of probable use and shall be specified as a minimum at a specific temperature, humidity, pressure and test voltage. It is recommended that insulation resistance be measured using forward and reversed polarity on applied dc voltages. The test methods customarily applied with the test article at room temperature may also be employed to determine the insulation resistance at temperatures up to the rated application temperature for the resistance thermometer. This is intended to be a non-destructive test.

5.1.1 The insulation resistance, as measured between the lead wires and case, does not represent the shunt resistance in parallel with the sensing element. Therefore, this test should not be used to estimate temperature measurement errors caused by inadequate insulation resistance across the sensing element.

5.2 Apparatus:

5.2.1 Because the insulation resistance is to be measured in conjunction with other tests, the thermometer shall be mounted as required for these tests.

5.2.2 Any equipment made for the purpose of insulation resistance testing shall be capable of measuring a resistance of at least 10 gigohms ($10^{10}\Omega$) at the specified test voltage. (**Warning**—Some instruments designed for insulation resistance testing are capable of producing lethal voltages (100 V or greater) at their measuring terminals. Such instruments should have warning labels and used only by supervised and well trained personnel.)

5.3 Measurement Procedure:

5.3.1 Make check measurements on a reference resistor of 10 gigohms ($10^{10}\Omega$). Check the measurement instrument to $\pm 5\%$ at the required minimum insulation resistance using a certified reference resistor. These results should accompany the test report on the platinum resistance thermometer (PRT). For example: When testing a PRT with a specified 100 megohm ($10^8\Omega$) minimum insulation resistance, the meter should be tested with a resistor that has a certified resistance of 100 megohms $\pm 5\%$.

5.3.2 Make insulation resistance measurements between the connecting wires and the shield or case, (1) before the thermometer is subjected to the conditions of any concurrent test (calibration, pressure, vibration), (2) during the test, and (3) immediately after the thermometer has returned to ambient conditions. All measured values of insulation resistance for each test condition shall exceed the minimum specified value.

5.3.3 Apply the specified measuring voltage between the joined connecting wires and the thermometer sheath or between circuits that are intended to be isolated. Take measurements with normal and reversed polarity and record the lower reading. Take the reading within 10 s of voltage application. Since only minimum values of insulation resistance are of concern, measurement accuracy need only be sufficient to

ensure that the minimum requirement is met. Insulation resistance measurements made during vibration require a high speed indicating device, such as an oscilloscope, to detect rapid transient changes in resistance.

5.4 The repeatability of the measurement's value is expected to be $\pm 5\%$ and the reproducibility $\pm 10\%$. See Appendix X4 for the results of round robin testing used to determine the repeatability and reproducibility of this test.

6. Thermometer Calibration

6.1 *Scope*—This test method covers recommended ways of calibrating industrial resistance thermometers. Methods common to most calibrations will be described, but the test methods presented do not usually test the thermometer under the actual conditions of use. The heat transfer conditions can vary widely, depending upon the medium, immersion length, rate of flow of the medium, etc. These and other conditions should be carefully evaluated before installing a thermometer for calibration or for temperature measurement. A resistance thermometer can be calibrated by using the comparison method or the fixed-point method, or both. The calibration results may be used to assess interchangeability, to establish a unique resistance-temperature relationship for the thermometer under test, or to verify conformance to a standard. In calibration tests, care should be taken to minimize thermal shock to the thermometer when inserting it into a heated or cooled environment, or when withdrawing it from a furnace or heated bath. Transitions should be made slowly, preheating or pre-cooling the thermometer when possible. This test is intended to be a non-destructive test. However, calibration of a thermometer to a higher temperature than it has previously experienced may change its calibration at lower temperatures. Resistances taken at ascending temperatures should be compared with those taken at descending temperatures to detect any change in the thermometer's characteristics (see Section 16, Thermal Hysteresis).

6.2 Calibration Methods:

6.2.1 *Comparison Method*—This method consists of measuring the resistance of the test thermometer in an isothermal medium, the temperature of which is determined by a calibrated reference thermometer. The reference thermometer may be a thermocouple, a liquid-in-glass thermometer, a resistance thermometer, or another thermometer of sufficient accuracy that has been calibrated by an approved method.

6.2.2 *Fixed-Point Method*—This method consists of measuring the resistance of the thermometer at the temperature defined by the equilibrium state between different phases of a pure substance or a mixture of pure substances. Each fixed point provides a calibration of the test thermometer at only one temperature defined by suitable equilibrium phases. The temperature is an intrinsic property of a properly specified equilibrium state of a substance, such as the freezing point at 1 atm. The temperature of some fixed-point devices can be repeated to $\pm 0.1\text{ m}^\circ\text{C}$ or better.

6.3 Apparatus and Procedure:

6.3.1 *Ice-Point Bath*—The most widely used and simplest fixed point is the ice-point. The ice point ($0\text{ }^\circ\text{C}$) may be realized with an error of less than $0.01\text{ }^\circ\text{C}$ if properly prepared and used. Significantly greater errors may be realized if certain

conditions exist. Users of this test method are referred to Practice E 563 which contains a more detailed discussion as to the proper preparation and use of ice point baths.

6.3.2 *Freezing Points*—In addition to the ice-point bath, the freezing-point temperature of various substances can be used as fixed points. The metal freezing point materials identified in Guide E 1502 are those most commonly employed.

6.3.3 *Triple Point of Water*—The triple point of water is a commonly used thermometric fixed point used for calibrating thermometers. To accurately realize the triple point of water, a triple point of water cell is used. This cell must be prepared and handled in a specific manner. The user is directed to Guide E 1750 for the preparation and use of water triple point cells.

6.3.4 *Fluid Baths*—Control the temperature of fluid baths by adjusting the amount of heating or cooling while agitating the bath fluid. Determine the amount of heating or cooling by the indication of a sensitive thermometer in the bath. Table 1 lists some of the common bath media and their useful ranges of operating temperatures. The bath medium must be chemically stable at the operating temperatures and be inert to the bath container and the thermometer material. The bath temperature must be stable with time and uniform over the working space at the operating temperatures. To test the stability of the bath, insert a reference thermometer into the working space of the bath and record the temperature as a function of time. The variations of the readings indicate the limit of stability of the bath. To test the temperature uniformity of the bath, while keeping the position of the first reference thermometer fixed in the working space of the bath, insert a second reference thermometer into various positions in the bath and determine the temperature relative to that of the first reference thermometer. The variations indicate the degree of temperature uniformity of the bath. A copper, aluminum, or other compatible

TABLE 1 Fluid Bath Media and Typical Operating Temperature Range

Media	Temperature Range, $^\circ\text{C}$
Halogen (CH Comp. Mixtures)	-150 to -70
Silicone Oils	-100 to 315 ^A
Light Mineral Oils	-75 to 200 ^A
Water	0 to 100
GIT (gallium-62.5 %; 2000 ^{B,C} indium-21.5 %; tin-16 %)	15 to
Dry Fluids (Fluidized Particle Bed)	75 to 850 ^A
Molten Salts	200 to 620 ^{A,D}
Liquid Tin	315 to 540 ^A

^A Fluids above $100\text{ }^\circ\text{C}$ may react violently if water or a wet object is immersed into them.

^B GIT does not boil until approximately $2000\text{ }^\circ\text{C}$, however it may attack some materials because it wets and removes oxide surfaces. Aluminum and silver are eroded slowly at room temperature and rapidly above $100\text{ }^\circ\text{C}$. 304 and 316 stainless steel has been in contact with GIT in air at $406\text{ }^\circ\text{C}$ for 520 days without damage. Maximum temperature when in contact with 304 or 316 SST should be $650\text{ }^\circ\text{C}$.

^C GIT, which is molten at room temperature and silvery colored, superficially resembles mercury. If these two liquids are inadvertently mixed together, a violent exothermic reaction will occur which is definitely hazardous. GIT can be distinguished from mercury as it readily wets glass containers whereas mercury does not wet glass and displays a characteristic meniscus at the interface. Proper labels should be applied to containers of the eutectic. "DO NOT MIX WITH MERCURY."

^D Some freshly prepared salt baths may require removal of corrosive components. Some salts will etch glass.

metallic block immersed completely and suspended in the bath fluid can be more stable and uniform in temperature than the bath. Such an arrangement with wells for thermometers in the block are suitable for calibrating thermometers. To determine the qualification of the block for the work, follow the procedure described above for fluid baths. The calibration procedure can be made convenient by controlling the bath temperature using a standard thermometer or with a working thermometer that has been calibrated at the various control points in terms of a standard thermometer. (**Warning**—Fluids may be easily ignited above their flash points. Fluids above 100 °C may erupt violently if water or wet objects are placed in them. Care should be taken when handling corrosive, toxic, or hazardous liquids and vapors.)

6.3.4.1 *Water Baths*— Water baths are satisfactory in the temperature range between 0 and 100 °C (see Test Method E 77). Some baths are available that combine the basic ideas shown in Test Method E 77 with pumps so that the bath fluid may be circulated to heat or cool an external bath. Many commercially available baths have self-contained heaters, cooling coils, stirrers, and temperature controllers.

6.3.4.2 *Salt Baths*—In the range of temperatures between 200 and 620 °C, salt baths are useful. A salt bath and procedures for its use are described in Test Method E 77. Salt baths for calibrating thermometers are commercially available. Some salt baths, designed primarily for heat treating metals and other materials, may be useful for calibrating thermometers. (**Warning**—Molten salt will react violently if water comes in contact with it (see the warning statement in 6.3.4). While some salts will etch glass, some freshly prepared salt baths may also require removal of corrosive components.)

6.3.4.3 *Refrigerated Baths*—In the range of temperatures below ambient, baths may be cooled by mechanical refrigeration or by cryogenics. The choice of fluids for such baths will be influenced by the temperature range. Means should be incorporated in the experimental design to avoid moisture condensation. There is some discussion on refrigerated bath fluids in Test Method E 77. (**Warning**—Some of these fluids are flammable at room temperature and some give off poisonous vapors. They must be handled with care and operating in a hooded area is recommended.)

6.3.4.4 *Vapor Baths*— A vapor bath may be used below 0 °C. (While the method is usable to temperatures in excess of 100 °C, it is more convenient to employ other types of baths.) Fig. 1 shows a typical vapor bath. An isothermal block houses the test thermometer and the standard thermometer. An electric heater is wound on the surface of the block. Vaporizing a cryogen (usually liquid nitrogen) will enable the vapors to cool the block. Apply a few milliwatts of power to the block to raise its temperature to the desired value for the calibration. Usually an electronic controller is used to stabilize the temperature of the block. A stable power supply is required to provide a constant boil-off rate of the cryogen. Depending on the size of the block, the number of test thermometers, and the heat conduction down the supports or connecting wires, radiation and convection baffles may be required in the bath to maintain the temperature of the block constant.

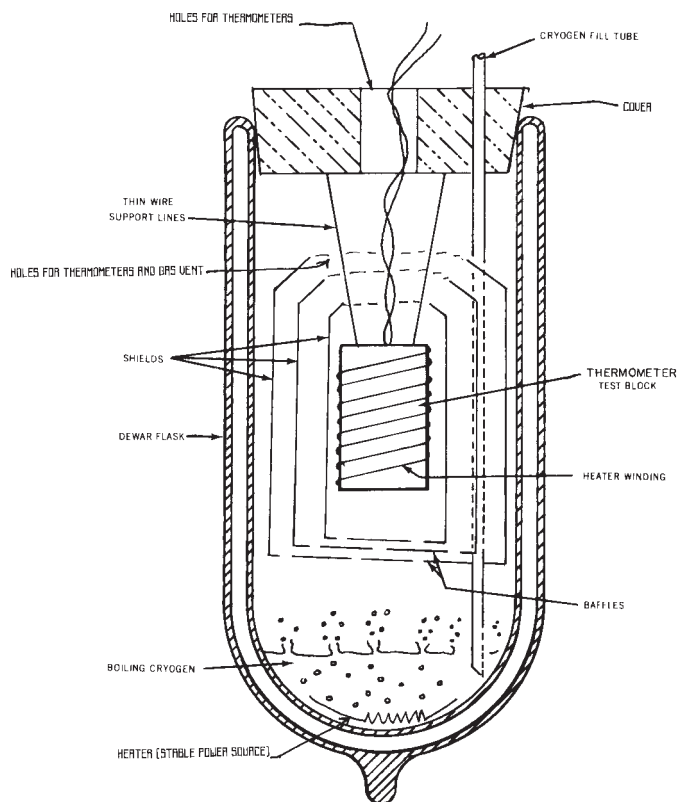

FIG. 1 Typical Vapor Bath

6.3.5 *Dry Block Calibrations*—At high temperatures a furnace fitted with a large metal block, can be used in calibration. Insert the test thermometer and the reference thermometer into wells in the block and make comparison calibrations. The method is particularly useful above 300 °C and is limited primarily by the temperature uniformity of the block and conduction error of the test thermometer. Make sure that the thermometer wells are both sufficiently deep and close fitting with the thermometers to make the conduction loss error negligible.

6.4 *Reference Thermometers*—Reference thermometers must have a known calibration, a stated uncertainty over the temperature range, and must be suitable for the intended calibration application.

6.4.1 *Standard Platinum Resistance Thermometer (SPRT)*—SPRTs are the most accurate reference thermometers and are used in defining the ITS-90⁵ from approximately -259 to 962 °C. The SPRT sensing element is made from pure platinum and supported essentially strain-free. Because of the delicate construction, the SPRT is easily damaged by mechanical shock and must be handled carefully to retain its calibration.

6.4.2 *Secondary Reference Thermometers*—Secondary Reference Thermometers are specially manufactured industrial platinum resistance thermometers that are subjected to special heat treating and calibration to establish their measurement

⁵ Preston-Thomas, H., *Metrologia* 27, 3 (1990); Mangum, B. W., *Journal of Research NIST* 95, 1990, p. 69.

uncertainty. These thermometers contain sensing element constructions that are not as easily affected by handling as are SPRT's. However, they also typically have higher measurement uncertainties and narrower usage ranges than SPRT's.

6.4.3 *Reference Thermocouples*—Thermocouples listed in Specification E 230 and Guide E 1751 that have been calibrated on the ITS-90 may also be used as reference thermometers. Noble metal thermocouples are the most commonly used reference thermocouples due to their stability and large usable temperature range.

6.5 *Measurement Instruments*—Several types of instruments can be used. They include analog and digital instruments and those that use resistance bridges, voltage comparison, or current and potential methods.

6.5.1 *AC and DC Bridges and Digital Multimeters*—AC bridges, DC bridges and digital multimeters are becoming increasingly common due to their ease of use and their compatibility with computerized data acquisition systems. These instruments typically provide the user the option of a digital display which can be set to provide readings in ohms, millivolts or temperature. The operating current of these instruments must be low enough that any self-heating of the thermometer is minimized (see Specification E 1137 and Section 12).

6.5.2 *Bridges*—Thermometer resistance can be measured in several bridge configurations. (See Appendix X1 and Appendix X2.) The measurement accuracy can be improved by using bridges that compensate for the connecting wire resistance and spurious thermal emf. Bridges are recommended where high accuracy (0.001 %) and ease of operation are desired.

6.5.3 *Potentiometers*—The laboratory potentiometer can be used to measure the resistance of a four-wire resistance thermometer by comparing the voltage drop across the thermometer element with that across a stable resistor of known value when the same current is flowing through both. The effect of spurious thermal emf should be eliminated by averaging two readings, one taken with normal current and one with the current reversed. A typical potentiometric circuit with current reversing switches is described in Appendix X3.

6.6 *Repeatability and Reproducibility (R & R)*—The R & R of the measurements shall be consistent with the specified calibration uncertainties. See Appendix X4 for the results of round robin testing to determine the repeatability and reproducibility of this test.

7. Minimum Immersion Length Test

7.1 *Scope*—Minimum immersion length shall be determined using the procedure described in 7.3. The user must relate this test method to the particular thermometer application, that is, the medium, velocity, turbulence of the fluid, etc., in choosing the design and immersion length of the thermometer. The temperature stability of the test bath and the sensitivity of the measurement instrumentation must be consistent with the specified temperature measurement uncertainty. This test is intended to be a non-destructive test.

7.1.1 This test may not be applicable to thermometers with immersion lengths less than 51 mm (2 in).

7.2 Apparatus:

7.2.1 *Ice-Point Bath*— See 6.3.1.

7.2.2 *Measurement Instrument*—See 6.5.

7.3 Procedure:

7.3.1 Insert the test PRT into the ice-point bath until no further insertion causes significant change in output. This insertion may include the mounting flange, threads, etc. The purpose of this requirement is to maximize heat transfer between the upper part of the thermometer and the bath so that the stem conduction error is negligible.

7.3.2 Use normal operating current (typically 1 mA) if specified. Otherwise, use an operating current which results in no significant self-heating. Record the resistance of the test PRT when equilibrium is reached.

7.3.3 Slowly withdraw the thermometer from the bath in small increments until the resistance increases equivalent to the specified measured uncertainty. Pause long enough after each incremental change in immersion depth to assure thermal equilibrium is reached.

NOTE 1—This depth of immersion in the bath as measured from the tip of the sensor to the surface of the liquid level is the minimum immersion length for the test PRT.

7.4 *Repeatability and Reproducibility (R & R)*—For thermometers with specified measurement uncertainties of 0.01 to 0.1 °C, the minimum immersion length test should be repeatable to ± 5 mm and reproducible to ± 10 mm. See Appendix X4 for the results of round robin testing to determine the repeatability and reproducibility of the test.

8. Pressure Test

8.1 *Scope*—This test is intended to determine the suitability of the resistance thermometer for operation at elevated pressures. The resistance thermometer should be tested in a vessel that has been completely filled with water. (**Warning**—Use compressible media only with extreme care because of an inherent explosion hazard. The test apparatus must also be designed to withstand higher test pressures than the test article. This test is intended to be non-destructive, unless the test article fails. If the test article passes the pressure test, it may then be used in the process application.)

8.2 Apparatus:

8.2.1 *Pressure Vessel*—A sketch of a pressure-tight vessel suitable for the test is shown in Fig. 2. The vessel shall be consistent with the pressure requirement.

8.2.2 *Ice-Point Bath*— See 6.3.1.

8.2.3 *Measurement Instruments*—The bridge, potentiometer, or electronic devices used to measure the resistance should be similar to those described in 6.5.

8.2.4 *Pressure Source*—A hand-operated hydraulic pump or other pumping device may be employed along with an indicating pressure gage. (**Warning**—Observe all the safety precautions applicable for liquid under pressure.)

8.2.5 *Insulation-Resistance Apparatus*—Use the apparatus indicated in Section 5 to measure the insulation resistance.

8.3 Procedure:

8.3.1 *Installation*—Mount the resistance thermometer in the pressure vessel (which has previously been filled with water) such that no leakage will occur. Connect the pressure source to the vessel and attach the thermometer wires to the

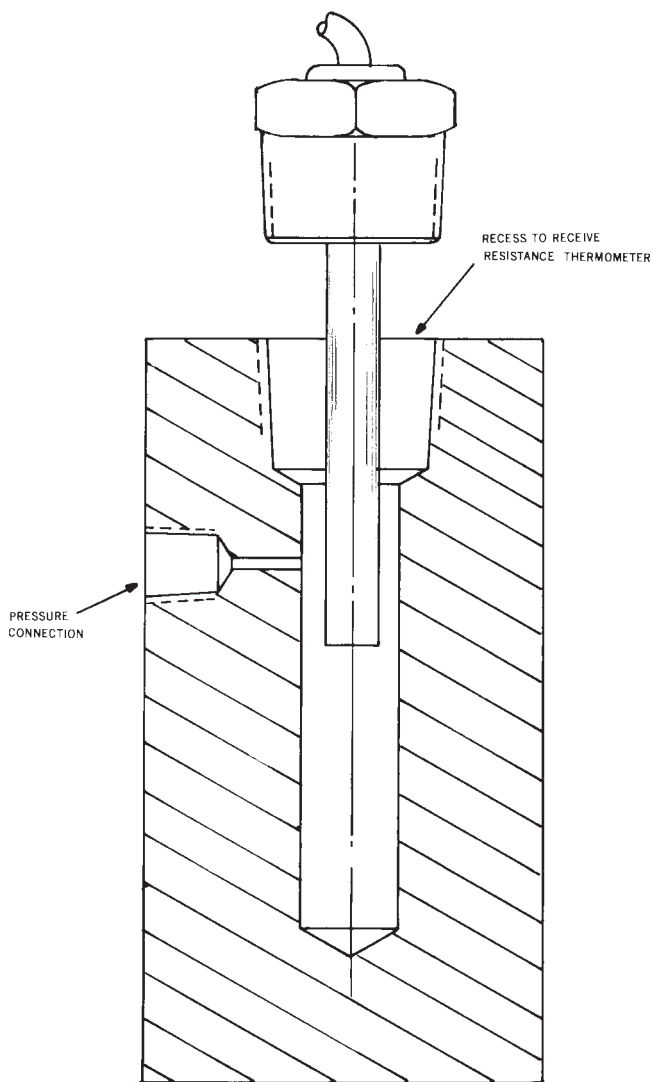

FIG. 2 Pressure Test Vessel

resistance measuring instrument. Insert the pressure vessel into the ice-point bath and allow the resistance reading to stabilize at temperature.

8.3.2 *Measurements*— With an appropriate excitation current and no hydrostatic pressure applied to the thermometer, allow the output to stabilize. Obtain a resistance measurement at the ice point followed by an insulation-resistance test (see Sections 5 and 6). Pressurize the vessel to within $\pm 10\%$ of the specified value. After the thermometer readings become steady, repeat the ice point resistance determination and the insulation resistance test with the pressure applied to the thermometer. Reduce the vessel pressure to atmospheric pressure and repeat the ice point and room temperature insulation resistance measurements. Remove the thermometer from the vessel and examine for deformation or any other effects due to the hydrostatic pressurization.

8.3.3 *Qualification*— The differences between the ice point resistance of the thermometer at the test pressure and the average of the two measurements at atmospheric pressure shall constitute the resistance thermometer's pressure stability.

8.4 *Repeatability and Reproducibility (R & R)*—There is a high probability that repetition of the pressure test on a particular thermometer (repeatability) or its subsequent testing by another tester (reproducibility) will provide the same indication of the thermometer's condition. The differences (8.3.3) are significant if greater than the icepoint measurement repeatability (see Table).

9. Thermal Response-Time Test

9.1 *Scope*—Thermal response time is that time required for a thermometer to react to a step change of temperature and reach the resistance corresponding to some specified fraction of the total temperature change. This method is applicable to measurements of response time longer than 1 s using strip chart recorders, but has been used successfully to measure shorter response times using digital data acquisition systems. The initial temperature should be ambient to avoid a superimposed transient during the transfer to the second temperature. The measured step response time is the time required, from the initiation of the step change of temperature, for the thermometer assembly to reach a temperature equal to the specified percentage of the step change (10 %, 50 %, 63.2 %, 90 %, 95 %, and so forth). Response time of a thermometric process is a function of heat flow into or out of the thermometer and is affected by the bath fluid, boundary layer conditions, velocity, turbulence of the fluid, etc. These conditions must be controlled for reproducible response time measurements. A practical upper limit of fluid velocity in a water test bath is about 1 m/s. At higher flow rates, fluid separation (cavitation) may occur, resulting in significant errors.

9.1.1 The thermometer to be tested is stabilized at an initial temperature and inserted rapidly into a fluid, usually water, flowing at a known velocity at a known final temperature. The resistance of the thermometer is monitored, and the elapsed time is measured from the instant of immersion until the thermometer has reached a final equilibrium resistance. The time is calculated corresponding to the specified percentage of the difference between the initial temperature and the water temperature. This measured time interval is the thermal response time of the measurement system. The response time with the thermometer in other media may be expected to vary significantly from this value. This test is intended to be non-destructive.

9.2 *Apparatus*—The temperature stability of the ambient conditions, the receiving bath, and the accuracy of the test PRT recording equipment must be consistent with the specified repeatability requirements.

9.2.1 *Fluid Bath*—A typical bath arrangement is shown in Fig. 3. The bath consists of a drum mounted on a vertical shaft driven by an adjustable speed motor. This provides a known and adjustable fluid velocity past the thermometer, which is held in a fixed position in the bath on the end of a pivoted arm. The arm, in its raised position, allows the thermometer to be stabilized at a known initial (usually ambient) temperature before being plunged rapidly into the bath. A switch activated by the arm, signals the start of the timing period at the instant the thermometer enters the fluid. Alternatively, in the case of a water bath, the electrical contact between the metal sheath of the probe and the water can be sensed to initiate the timing

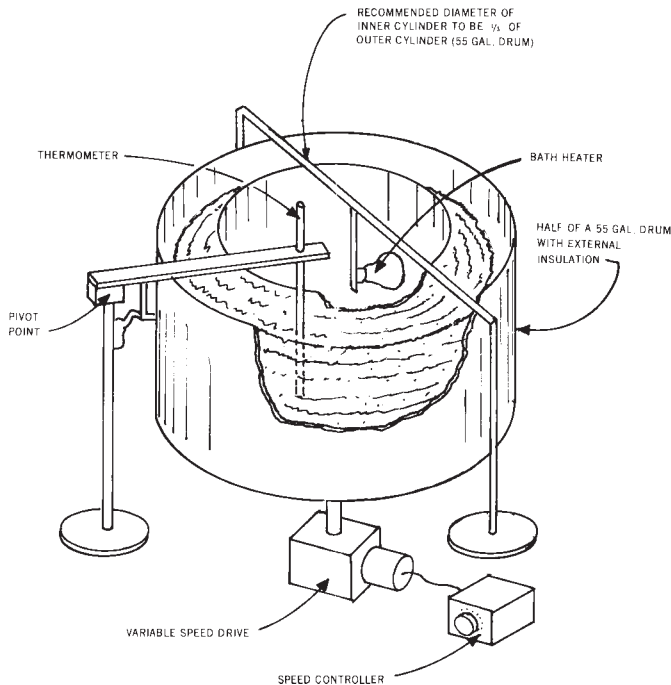

FIG. 3 Typical Bath Arrangement

period. The water bath temperature can be controlled with infrared lamps directed at the inner walls of the water chamber however other heating methods are possible.

9.2.2 *Measurement Instruments*—Instruments that are compatible with the thermometer and that have an output suitable for a recorder can be used to monitor the thermometer resistance. Current to the thermometer must be limited to a value below the thermometer’s self heating threshold to avoid self heating error. See 6.5.

9.2.3 *Recorder*—A strip chart, x-y or oscilloscope recorder, or digital data acquisition system shall be provided to record the temperature versus time measurement. The time base shall be calibrated.

9.3 *Procedure:*

9.3.1 *Installation and Arrangement for Test*—Mount the thermometer in a suitable fixture on the pivoted arm so that the thermometer can be immersed to at least its minimum immersion length in the bath. Stabilize the bath at the specified temperature. Rotate the bath to provide the specified fluid velocity (for water, the fluid velocity is typically 1 m/s). Adjust the span and zero the controls of the recorder to provide a convenient chart width, using resistors in place of the thermometer to simulate both ambient and bath temperatures. The temperature corresponding to the specified percentage of the temperature difference may be simulated in a like manner, and a line corresponding to this temperature drawn on the recorder chart.

9.3.2 *Measurement*— Stabilize the thermometer, in its raised position, at ambient temperature, then rapidly immerse it in the fluid bath. The time sweep is automatically started at the instant the thermometer enters the bath, and the recording is continued until the thermometer has reached the specified change in temperature. Make at least three measurements on

each thermometer, and make certain that they agree within the specified repeatability.

9.4 *Repeatability and Reproducibility (R & R)*—The R & R of 63.2 % thermal response times, for step changes from the ambient temperatures to baths at 70 °C, are expected to be $\pm 5\%$ and $\pm 10\%$, respectively, with thermometers of response times of 1 to 30 s (see Appendix X4 for the results of round robin testing to determine the repeatability and reproducibility of this test).

10. *Vibration Test*

10.1 *Scope*—In industrial applications, resistance thermometers are subject to significant vibratory motion. In this test the performance characteristics of thermometers are examined both during and after being subjected to specified limits of vibration. The following method describes sine-wave vibration equipment, fixtures, fixture evaluation, procedures and acceptance criteria. The actual test duration, vibration levels, frequency spectrum and performance requirements are to be specified by the user. All tests and evaluations shall be performed at a temperature of 25 ± 10 °C unless otherwise specified. This test may affect the characteristics of the test article in a manner not immediately apparent from resistance-temperature measurements made after the test. If the test articles are to be sold or used after vibration test, additional qualification tests may be needed to observe possible intermittent temperature indication.

10.2 *Apparatus:*

10.2.1 *Vibration Driver*— A driver shall be used that is capable of producing sinusoidal motion in the acceleration ranges and frequencies specified. The driver shall have the following minimal capabilities:

10.2.1.1 Adequate force to drive the vibration fixture and the test specimen to the double amplitude (peak-to-peak displacement) and acceleration (*g*-level) specified.

10.2.1.2 The ability to sweep logarithmically the specified frequency spectrum at specified rates (not to exceed 1 octave/min).

10.2.1.3 The ability to control vibration amplitude and acceleration (*g*-level) to $\pm 10\%$ of the specified level.

10.2.1.4 The ability to control the frequency to $\pm 2\%$.

10.2.2 *Vibration Fixtures*—These requirements establish the minimum standards for vibration fixtures. In general the intent is to provide a fixture which most nearly simulates the test article’s conditions of service.

10.2.2.1 *Material*—Magnesium, aluminum, or other materials with high internal damping factors.

10.2.2.2 Fabrication methods in order of preference:

- (1) Cast, then machined to desired dimensions.
- (2) Machined from solid stock.
- (3) Welded assembly.
- (4) Bolted assembly.

10.2.3 *Vibration-Fixture Evaluation:*

10.2.3.1 The following conditions shall exist for fixture evaluations:

(1) All fixtures shall be evaluated with either a prototype or a dummy specimen in place. This dummy shall be dynamically equivalent to and mounted in the same way as the specimen.

(2) All evaluation sweeps shall cover the entire frequency spectrum specified.

(3) Sweep rate of the frequency shall not exceed one octave per minute, so that all resonances can fully respond.

(4) A sufficient number of accelerometers or multiple sweeps shall be utilized so that information is obtained at the specimen mounting area in all three major orthogonal axes. Continuous records shall be made for each sweep. Resonant peak levels and frequencies shall be measured.

(5) A control accelerometer shall be placed on the fixture as close to the test specimen mounting point as possible.

10.2.3.2 Vibration fixture test runs shall be made as follows:

(1) Using the conditions described above (10.2.1, 10.2.2, and 10.2.3) and the test levels and frequencies specified by the user, perform a vibration sweep on each of the three major orthogonal axes of the fixture.

(2) Make a continuous record of the monitoring accelerometer output.

(3) Note resonant frequencies and amplitudes.

(4) Relocate monitoring accelerometers as necessary to completely define the vibration fixture vibration response around the specimen mounting plane.

10.2.4 Each vibration fixture, when evaluated according to the above requirements, shall meet the following minimum standards:

10.2.4.1 Sinusoidal transmissibility shall be such that the vibration input in the axis of applied vibration of the specimen mounting point shall be within ± 3 dB of that specified over the entire frequency band, and

10.2.4.2 Sinusoidal cross-talk (vibration input in either axis orthogonal to the axis of applied vibration at the specimen mounting point) shall not exceed the input.

10.3 *Procedure:*

10.3.1 *Installations:*

10.3.1.1 Attach the resistance thermometer to the vibration fixture in a manner which simulates as closely as possible the mounting method to be used in service. The thermometer signal cable shall be clamped to the fixture at a point no more than 51 mm (2 in.) from the cable end closure if not secured otherwise.

10.3.1.2 Mount a control accelerometer adjacent to the mounting point of the thermometer.

10.3.1.3 Locate a monitoring accelerometer on the test specimen, usually near the resistance thermometer element. This location may vary when subsequent testing proves that other portions of the thermometer are more sensitive to vibration. Continuously record the output of the monitoring accelerometer. Ensure that the monitoring accelerometer has a small mass relative to that of the test specimen. On very small thermometers, or during vibration testing at high temperatures, the use of a monitoring accelerometer may not be possible.

10.3.2 *Resonant Search:*

10.3.2.1 Sweep through the specified frequency spectrum at about approximately one fourth the specified double amplitude and acceleration. Sweep rate is to be logarithmic and is not to exceed 1 octave/min.

10.3.2.2 During this sweep, note all resonant frequencies where the response (displacement of the resonating thermometer divided by the displacement of the vibration fixture) is greater than two. Resonances with a response less than two shall be ignored.

10.3.2.3 In addition to the monitoring accelerometer described in 10.3.1, resonant frequencies may also be observed aurally or visually, with strobe lights, microscopes, etc.

10.3.2.4 Repeat the resonant search in the remaining two major orthogonal axes.

10.3.2.5 Remove any monitoring accelerometers used.

10.3.3 *Resonance Dwell:*

10.3.3.1 Select the four most significant resonant frequencies of each axis, if any, noted in 10.3.2. The end usage, such as known vibration in the actual thermometer field location, should be considered.

NOTE 2—The resonant frequencies chosen may not necessarily be those with the largest resonance responses. Vibration test and product design personnel may choose other frequencies that may be actually more destructive to the test specimen. End usage, such as known vibrations, or lack of vibrations, in the actual thermometer field locations, should be considered.

10.3.3.2 Vibrate at one of the resonant frequencies at the level and duration specified by the user.

10.3.3.3 Proceed to one of the remaining resonant frequencies and repeat 10.3.3.2.

10.3.3.4 Continue until the selected resonance frequencies on all axes have been tested.

10.3.4 *Cycling Vibration*—After the resonance dwell vibration test described in 10.3.3 is finished, perform the cycling vibration as follows:

10.3.4.1 Adjust the vibration equipment to sweep the specified frequency range at 1 octave/min. Start at the lowest frequency specified.

10.3.4.2 Adjust for the specified amplitude and acceleration.

10.3.4.3 Vibrate on one axis for the time specified by the user less the time taken for vibrating at resonant dwells.

10.3.4.4 Repeat on the remaining two major orthogonal axes.

10.4 *Thermometer Monitoring*—The output of the thermometer shall be monitored during resonant dwells and cycling vibration such that momentary thermometer resistance variations, interruptions, or shorts to the thermometer housing are detected. Monitoring equipment should have a frequency response flat from dc to 10 kHz. DC shift or spikes observed (for example, on the oscilloscope) during vibration are indicative of potential sensor failure modes.

10.5 *Pre and Post-Vibration Measurements*—Visual examination shall show no defects with the unaided eye. Measure insulation resistance (in accordance with Section 5) and satisfy the specified requirements. Measure ice-point resistance (in accordance with 6.3.1) and satisfy the specified requirements. Additional tests may include thermal cycling (in accordance with Section 16) to detect intermittent behavior during temperature transients.

11. Mechanical Shock Test

11.1 *Scope*—Mechanical shock may occur during shipping and handling or as a result of surges in process equipment. This

test simulates the mechanical shock conditions that an industrial thermometer is expected to withstand, using commercial test equipment capable of producing a shock pulse of reproducible duration and acceleration. This test may be destructive and may affect the characteristics of the test article which should be qualified after the shock tests for stability during thermal cycles.

11.2 Apparatus:

11.2.1 *Shock Test Table*— A variable-drop-height table, designed to meet MIL-STD 202 (Method 213B) condition or equal is used to yield a half sine acceleration pulse of known time duration and peak acceleration. The test carriage is released for a free fall drop, stopped by impact on a steel spring and arrested on rebound. Additional weights are used to compensate for the test article to obtain the required pulse duration and peak acceleration. Other methods may also be used.

11.2.2 *Monitoring Equipment*—An accelerometer and a triggered dual trace oscilloscope with a frequency response of 2000 Hz or greater shall be used for calibration of the shock pulse and for monitoring the test unit. The oscilloscope sensitivity shall be sufficient to allow detection of a shock pulse deviation greater than 10 % of the required value.

11.3 Procedure:

11.3.1 The vibration fixture of 10.2.2 less test unit shall be installed on the shock machine carriage with additional weight added equal to that of the test unit plus weights for establishing the desired shock pulse. At least one test drop shall be made to verify acceleration and pulse duration prior to installing the thermometer. Test acceleration shall be within $\pm 10\%$ of specified *g*-level and repeatability of pulse duration shall be within ± 1 ms.

11.3.2 After calibration drops have demonstrated the correct wave shape, the thermometer shall be mounted in the vibration test fixture and energized with a 1mA dc excitation through two active connecting wires. A series circuit containing a 100 Ω resistor shall be used as a shunt to obtain an oscilloscope trace deflection of at least 76 mm (3 in.) for monitoring.

11.3.3 The test carriage shall be raised to the calibrated height and dropped three times in each of the mutually perpendicular axes of the thermometer with shock pulse and excitation trace monitored during each drop.

11.4 Test Monitoring:

11.4.1 Any discontinuity observed on the monitoring trace shall be considered as indicative of test unit failure. The dc excitation in accordance with 11.3.2 will result in a straight line oscilloscope trace unless defects such as open circuits, partial or complete short circuits, or grounding faults occur.

12. Self-Heating Tests

12.1 *Scope*—The magnitude of self-heating depends on the power ($P = RI^2$) generated in the thermometer element and wires, and on the heat conduction from the thermometer element to the bath medium. In this test the power that would cause a unit increase in temperature is determined at a given temperature with the thermometer immersed in a specified heat transfer medium. The thermometer current at which the self-heating is equal to the specified limits of uncertainty shall be declared. To conduct self-heating tests, the measurement in-

strumentation accuracy and the temperature stability of the bath must correspond to better than the specified repeatability of the self-heating effect test or the specified limit of self-heating effect at the operating current. The thermometer may be tested for self-heating at actual operating conditions by the following procedures (12.2 or 12.3). This test is intended to be non-destructive although excessive heating at currents more than the manufacturer's maximum current rating may effect calibration or operability of the thermometer.

12.2 Self-Heating Test in Water:

12.2.1 Apparatus:

12.2.1.1 *Water Bath*—A well-stirred bath, held at a steady temperature near 25 °C (see 6.3.2 for description of suitable baths). The bath shown in Fig. 3 for the thermal response time is suitable for this test also. The rotation should correspond to a water flow rate of 1 m/s.

12.2.1.2 *Measurement Instruments*—See 6.5.

12.2.2 Procedure:

12.2.2.1 Immerse the resistance thermometer in the water bath to at least the minimum immersion length. Measure the equilibrium resistance of the thermometer at the lowest continuously applied current for which the detector sensitivity would give satisfactory measurement precision. Then measure the equilibrium resistance with a higher current (2 \times , 5 \times , or 10 \times , depending upon the sensitivity of the measurement system). Repeat the measurement with the initial lower current to assure that the bath temperature has not changed during the test.

NOTE 3—The period for the application of the test currents shall be not less than the time required to reach thermal equilibrium, typically 10 time constants.

12.2.2.2 Calculate the self-heating constant expressed in mW/°C from the following equation:

$$\text{Self-heating constant, mW/}^\circ\text{C} = S(P_2 - P_1) / (R_2 - R_1) \quad (1)$$

where:

R_1 = resistance at the lower power dissipation, Ω ,

R_2 = resistance at the higher power dissipation, Ω ,

S = thermometer sensitivity (dR/dt), at the bath temperature, $\Omega/^\circ\text{C}$,

P_1 = lower power dissipation ($R_1 I_1^2$), mW, and

P_2 = higher power dissipation ($R_2 I_2^2$), mW.

12.2.2.3 Often, the minimum-power self-heating for 1°C rise in the apparent temperature of the thermometer is specified. To test for the minimum-power self-heating requirement for 1 °C rise, measure the equilibrium resistance of the thermometer at the lower current as in 12.2.2.1, then increase the current to correspond to the specified minimum power level (for example, $RI^2 = 33$ mW) and measure the equilibrium resistance. If the resistance change is greater than 1 °C the self heating of the thermometer is too large.

12.3 Self-Heating in Air or Other Gases:

12.3.1 Apparatus:

12.3.1.1 Stream of gas at a steady temperature near 25 °C, flowing at a velocity within 5 m/s $\pm 10\%$ in a tube of diameter at least twice the recommended immersion depth of the thermometer. The tube also shall be near 25 °C to avoid radiation effects.

12.3.1.2 *Measurement Instruments*—See 6.5.

12.3.2 *Procedure*:

12.3.2.1 Install the thermometer normal to the gas stream in accordance with the recommendation of the manufacturers. Measure the equilibrium resistances and calculate the self-heating effect as in 12.2.2 or test in accordance with 12.2.2.3.

12.4 *Repeatability and Reproducibility (R & R)*—The repeatability and reproducibility of the self heating constant of the thermometer depends primarily on maintaining the same surface heat transfer characteristics in the test apparatus throughout the test. See Appendix X4 for the results of round robin testing to determine the repeatability and reproducibility of this test.

13. Stability Test

13.1 *Scope*—A thermometer should maintain its specified resistance-temperature characteristic for long periods of time while being operated within its specified temperature limits. Test for the thermometer stability is made by observing the ice-point resistance after subjecting the thermometer for specified intervals at the upper temperature limit. This test is intended to be non-destructive.

13.2 *Apparatus*:

13.2.1 *Furnace*—The test furnace may be any of those commonly used with thermocouples or resistance thermometers that are capable of maintaining the specified upper temperature limit of the test thermometer. The heating zone of the furnace should be at least four times the thermometer minimum immersion length. Temperature difference in this zone, longitudinal and radial, shall not exceed 5 °C or 2 % of the temperature. The furnace may be equipped with a perforated ceramic cover plate capable of accommodating the outside diameter of the thermometer sheath. The test furnace temperature shall be controlled and recorded to within ± 10 °C or ± 15 % of the specified temperature.

13.2.2 *Ice-Point Bath*— See 6.3.1.

13.2.3 *Reference Thermometers and Measurement Instruments*—See 6.4 and 6.5.

13.2.4 *Procedure*:

13.2.4.1 *Ice Point*—First obtain the ice-point reading as described in 6.3.1.

13.2.4.2 *Elevated Temperature*—Insert the thermometer into the cold test furnace. Heat and control the furnace at the specified upper temperature limit of the test thermometer. Take care to ensure that the temperature of any part of the thermometer does not exceed the manufacturer's specification.

13.2.4.3 *Temperature Soak*— Maintain test thermometer at the upper temperature limit for the specified interval of time, typically three to seven days. Cool the furnace to room temperature and then remove the thermometer. Obtain another ice-point reading. Compare the resistance reading after the temperature soak with the initial ice-point measurement. The difference between the two measurements is the resistance change of the thermometer after the temperature soak.

NOTE 4—Heating and cooling rates should not exceed 50 °C/min.

13.2.4.4 *Long-Term Stability*—Repeat the above test at regular intervals for the specified period of time. Determine the

ice-point resistance after each temperature soak and compare with the initial ice-point reading.

13.2.5 *Interpretation of Results*:

13.2.5.1 The temperature stability of the test thermometer is specified as the maximum minus the minimum recorded ice-point resistance times the dt/dR of the thermometer over the total period of test time at the upper temperature limit. The equivalent temperature drift in the thermometer resistance is the ratio of this change in resistance to the total heating time, for example, ΔR per 100 h.

13.2.5.2 *Ice-Point Resistance versus Time Plot*—Maintain the ice-point resistance versus time plot during the test to indicate the trends in the thermometer resistance. For reference, the ice-point readings should be obtained at the same time and compared with those on similar thermometers that have not been subjected to elevated temperatures. The results on the reference thermometers constitute the R & R of the measurements.

14. Thermoelectric Effect Test

14.1 *Scope*:

14.1.1 Thermal emf in the measurement circuit using dc excitation can cause an error in the indicated temperature. Where the measuring apparatus is suitable, reversing the polarity of the excitation current and averaging readings will help eliminate this error.

14.1.2 The thermoelectric effect depends on the dissimilar metals that are used in the manufacture of the thermometer (particularly in its internal leads), the temperature, and the temperature gradients. The test condition should closely approximate the conditions of use of the thermometer. The various baths described in 6.3 could be used in the test. The user of the thermometer must determine the total thermal emf correction under the actual conditions of application. This test is non-destructive.

14.2 *Apparatus*:

14.2.1 *Ice-Point Bath, Water Bath, Salt Bath, or Furnace with Temperature Equalizing Block*—See 6.3.

14.2.2 *Measurement Instruments*—See 6.5.

14.3 *Procedure*:

14.3.1 Obtain all readings as a direct thermal emf measurement, or as the difference between dc resistance readings with the normal and reversed currents. Record polarity of all measurements relative to the lead connections.

14.3.2 Insert the thermometer into the bath and slowly vary the immersion length between the minimum specified immersion length (see Section 7) and the maximum practical length.

14.3.3 Find the immersion length at which the maximum thermal emf is observed. Identify the external connecting wires used. Conduct the test with other combinations of leads.

14.4 *Interpretation of Results*:

14.4.1 When measurements are made with the measuring current in one direction, the error due to the thermoelectric effect is either the resistance equivalent (of the thermal emf) measured using a potentiometer, or one-half of the difference between resistances measured with normal and reversed currents. The error has a polarity as recorded in 14.3.1.

14.4.2 When the thermoelectric effect is negligible relative to calibration accuracy requirements, the need to eliminate it by the methods of 14.1.1 or 6.5.2 may not be necessary during other measurements.

14.5 *Repeatability and Reproducibility (R & R)*—The R & R of the thermal emf tests shall be $\pm 1 \mu\text{V}$ when taking direct thermal emf measurements (see Appendix X4 for the results of round robin testing to determine the repeatability and reproducibility of this test).

15. Humidity Test

15.1 *Scope*—Humidity testing is used to determine if the test PRT is sealed against ambient moisture. Moisture contamination can cause erroneous readings in PRT's. This test is intended to be non-destructive.

15.2 *Procedure*—This entire thermometer shall be exposed to a minimum 80 % relative humidity condition (noncondensing) at ambient temperature and pressure for a period of ten days. Following this exposure, the test article shall be tested for insulation resistance as defined in Section 5.

16. Thermal Cycle and Thermal Hysteresis Test

16.1 *Scope*—Thermal cycle testing is used to simulate temperature changes that can cause physical or operational changes or defects. Hysteresis testing quantifies the amount of change in the test PRT when exposed to thermal cycling conditions. A maximum rate of heating or cooling of about 50 °C/min is intended. This test is intended to be non-destructive, but may produce defects that should be examined by additional testing before sale or use of the test specimen.

16.2 Apparatus:

16.2.1 A fluid bath or a metal block furnace that can be operated at the specific test temperatures with stability better than the uncertainty limit and with wells deeper than the thermometer's minimum immersion depth.

16.2.2 *Measurement Instruments*—Reference thermometer, bridge, potentiometer, or other suitable resistance thermometer monitoring instruments. See 6.5.

16.3 Procedure:

16.3.1 Insert the reference thermometer into the test zone and monitor its resistance with the equipment described in 6.5. Insert the test PRT into the test zone to at least the minimum immersion length.

16.3.2 Starting at room ambient, raise the temperature of the test PRT to the specified maximum temperature ($\pm 5 \text{ }^\circ\text{C}$) and hold for the required time interval.

16.3.3 Reduce the temperature of the test thermometer to the temperature midway between the specified maximum and minimum, and take a resistance reading of the test thermometer (use caution to not undershoot the required temperature).

16.3.4 Reduce the test thermometer temperature to the specified minimum temperature ($\pm 5 \text{ }^\circ\text{C}$) and hold for the required time interval.

16.3.5 Raise the temperature of the test thermometer to the temperature midway between the specified maximum and minimum, and take a resistance reading of the test thermometer (Use caution to not overshoot the required temperature).

16.3.6 Raise the test thermometer to the specified maximum temperature and continue for the specified number of cycles.

16.3.7 Calculate the average and standard deviation for the data set taken following the maximum and minimum temperature exposures. The difference between the two averages can be used to quantify hysteresis, while the standard deviation can be used to quantify repeatability.

17. Thermal Shock Test

17.1 Scope

17.1.1 Thermal shock conditions may influence the accuracy and reliability of the thermometer in service. This test is performed to verify the thermometer stability and circuit integrity when subjected to rapid cycles between temperature extremes. This test is to be conducted under one of the Standard Test Conditions shown in Table 2.

17.1.2 The thermometer stability may be influenced by previous thermal treatment. Consult the thermometer manufacturer to determine whether any thermal conditioning is needed before conducting this test.

17.1.3 (**Warning**—thermometers that are not air tight may develop internal condensation when exposed to cold temperatures and build up high pressure when rapidly heated.)

17.1.4 The thermometer shall be tested using a specified depth of immersion that is comparable to the thermometer installation in service. This depth may be greater than the minimum immersion length (see Section 7).

17.2 Apparatus

17.2.1 *Temperature Chambers*—The thermometer shall be cycled between two separate temperature chambers or baths. The thermometer shall be inserted and withdrawn from the test media at a rate not less than 25 mm/s (1 in/s). The working zone of the chamber shall be at least four times the length of the resistance thermometer element. The temperature variation in this zone shall not exceed the greater of 5 °C or 2 % of the specified test temperature in °C. The test chamber shall be controlled and recorded to within $\pm 10 \text{ }^\circ\text{C}$ or $\pm 5 \text{ } \%$ of the specified test temperature in °C, whichever greater.

17.2.2 *Ice Point Bath*—See Practice E 563.

17.2.3 *Reference Thermometers and Measurement Instruments*—See 6.4 and 6.5.

17.3 Procedure

17.3.1 Subject the thermometer to the specified high test temperature to initialize thermal history. Allow the thermometer to equilibrate and then cool to ambient conditions.

17.3.2 *Insulation Resistance*—Measure and record the room temperature insulation resistance between lead wire and case as described in Section 5.

TABLE 2 Standard Test Conditions

Condition	Low Test Temperature ^A		High Test Temperature	
	°C	Medium ^B	°C	Medium ^B
A	<i>User Specified Condition</i>			
B	-196 °C	LN ₂	150 °C	Air
C	-65 °C	Air	150 °C	Air
D	-65 °C	Air	400 °C	Air
E	21 °C	Air	200 °C	Air
F	21 °C	Air	650 °C	Air

^A See 17.1.3 for warning note.

^B The heating and cooling rates are influenced by the test media. Using a stirred liquid bath can enhance heat transfer and increase the severity of the test condition.

17.3.3 *Ice Point*—Measure and record the resistance at the ice point as described in 6.3.1.

17.3.4 *Low Temperature*—Insert the thermometer into the cold chamber or bath, which has been set to the specified low test temperature. Care should be taken to maintain the specified immersion length.

17.3.5 *Temperature Soak*—Allow the thermometer to reach the test temperature and then remove directly to ambient conditions.

17.3.6 *High Temperature*—Insert the thermometer into the high temperature chamber or bath, which has been set to the specified high test temperature. Care should be taken to maintain the specified immersion length.

17.3.7 *Temperature Soak*—Allow the thermometer to reach the test temperature and then remove directly to ambient conditions.

17.3.8 Repeat steps 17.3.4-17.3.7 for ten shocks, or as specified otherwise. On the final cycle, monitor the thermometer response during the entire heating and cooling cycle using a strip chart recorder or similar device with a sample rate not less than 6 Hz.

17.3.9 Repeat the ice-point resistance measurement.

17.3.10 Repeat the room temperature insulation resistance measurement.

17.4 *Test Report*

17.4.1 The test report shall include the test conditions (see Table 2), insulation resistance values and test voltage, ice-point resistance values, and the strip chart recording documenting the final heating and cooling cycle.

18. Precision and Bias

18.1 The expected limits of repeatability and reproducibility from results of round-robin tests on insulation resistance, thermometer calibration, minimum immersion length, thermal response time, self heating, and thermoelectric effect are given in Appendix X4.

18.2 The limits of repeatability and reproducibility of the tests described in these test methods depend on the standards and the measurement instrument and associated equipment that are used, and on the experience and care exercised in maintaining and using the equipment by the operator.

18.3 No information is presented about the precision or bias for the tests on pressure, vibration, shock, stability, humidity, thermal cycle or thermal shock since these test methods describe only environmental test conditions. However, these tests may be performed in combination with other tests such as calibration or insulation resistance which do have estimates of repeatability and reproducibility as described above.

19. Keywords

19.1 calibration; IR; PRT; RTD's; SPRT; standard reference thermometer; testing

APPENDIXES

(Nonmandatory Information)

X1. THERMOMETER WIRE CONFIGURATIONS

X1.1 Typical thermometer wire configurations are shown schematically in Fig. X1.1.

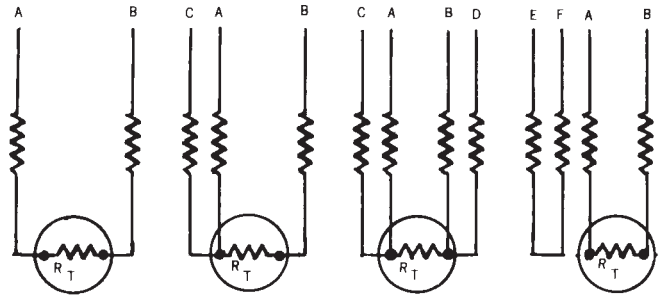

FIG. X1.1 Thermometer Wire Configurations

X2. BRIDGE METHODS FOR RESISTANCE THERMOMETRY

X2.1 Fig. X2.1 shows a two-wire thermometer connected to a simple bridge. When the bridge is at balance with no spurious thermal emf, then:

$$R_T + L_1 + L_2 = (R_B R_2/R_1) \quad (X2.1)$$

X2.2 Fig. X2.2 shows a two-measurement method for determining the resistance of a three-wire thermometer employing a simple bridge. When the bridge is first balanced, then:

$$R_T + L_1 + L_2 = (R_{B1} R_2/R_1) \quad (X2.2)$$

$$L_2 + L_3 = (R_{B2} R_2/R_1)$$

$$L_1 = L_3$$

$$R_T = (R_{B1} R_2/R_1) - (R_{B2} R_2/R_1)$$

X2.3 Fig. X2.3 shows a two-measurement method for determining the resistance of a four-wire compensating loop thermometer employing a simple bridge. When the bridge is first balanced, then:

$$R_T + L_1 + L_2 = (R_{B1} R_2/R_1) \quad (X2.3)$$

and at the second balance,

$$L_3 + L_4 = (R_{B2} R_2/R_1) \quad (X2.4)$$

Since the thermometer is designed so that:

$$L_1 + L_2 = L_3 + L_4 \quad (X2.5)$$

hence:

$$R_T = (R_{B1} R_2/R_1) - (R_{B2} R_2/R_1) \quad (X2.6)$$

X2.4 Fig. X2.4 shows a method for determining the resistance of a three-wire thermometer employing a modified bridge. When the bridge is balanced, then:

$$R_T + L_1 = (R_B + L_2)(R_2/R_1) \quad (X2.7)$$

Since the thermometer and the bridge are designed so that:

$$L_1 = L_2 \quad (X2.8)$$

and

$$R_1 = R_2 \quad (X2.9)$$

hence:

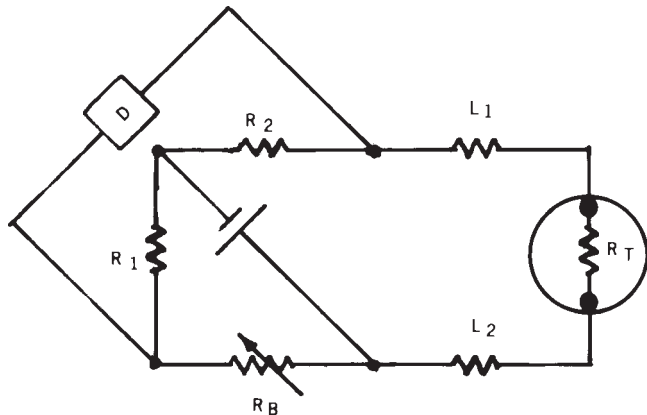

FIG. X2.1 Two-Wire Thermometer Connected to a Simple Bridge

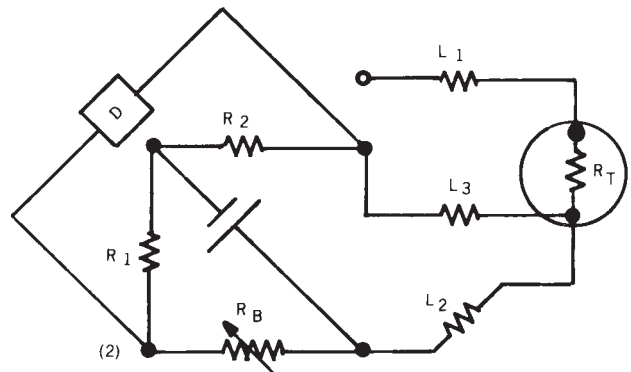
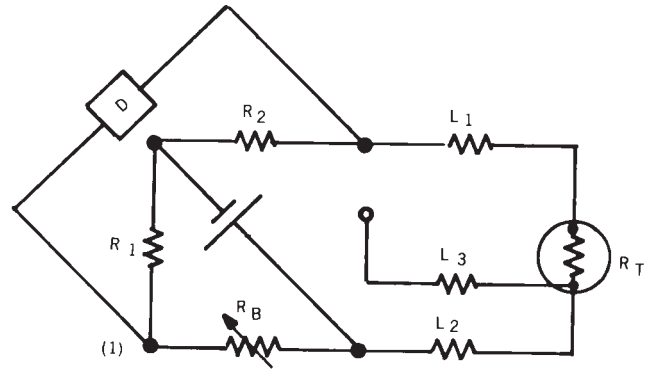

FIG. X2.2 Two Measurement Method for Determining the Resistance of a Three-Wire Thermometer Employing a Simple Bridge

$$R_T = R_B \quad (X2.10)$$

X2.5 Fig. X2.5 shows a method for determining the resistance of a compensated four-wire thermometer employing a modified bridge. When the bridge is balanced, then:

$$R_T + L_1 + L_2 = (R_B + L_3 + L_4)(R_2/R_1) \quad (X2.11)$$

Since the thermometer and the bridge are designed so that:

$$L_1 + L_2 = L_3 + L_4 \quad (X2.12)$$

and

$$R_1 = R_2 \quad (X2.13)$$

hence:

$$R_T = R_B \quad (X2.14)$$

(In all of the above (X2.2, X2.3, X2.4, and X2.5) the assumption that connecting wire resistances are equal may be only approximately true.)

X2.6 Fig. X2.6 shows the Mueller bridge method for determining the resistance of a four-terminal thermometer. When the bridge is balanced with the thermometer in the NORMAL connection, then:

$$R_T + L_1 = (R_{B1} + L_2)(R_2/R_1) \quad (X2.15)$$

and when balanced in the REVERSE connection, then:

$$R_T + L_2 = (R_{B2} + L_1)(R_2/R_1) \quad (X2.16)$$

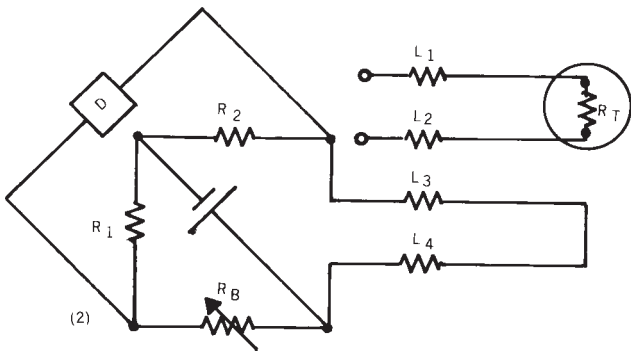
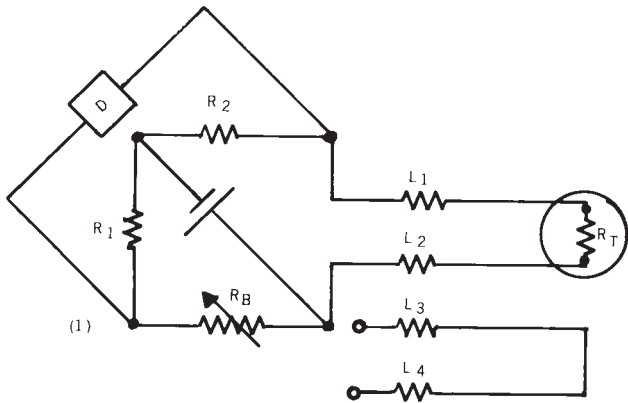

FIG. X2.3 Two-Measurement Method for Determining the Resistance of a Compensating Loop Four-Wire Thermometer Employing a Simple Bridge

Since the bridge is adjusted so that:

$$R_2 = R_1 \quad (X2.17)$$

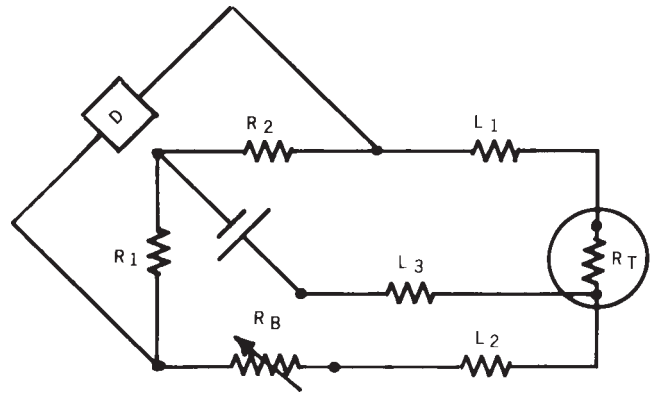

FIG. X2.4 Determination of the Resistance of a Three-Wire Thermometer Employing a Modified Bridge

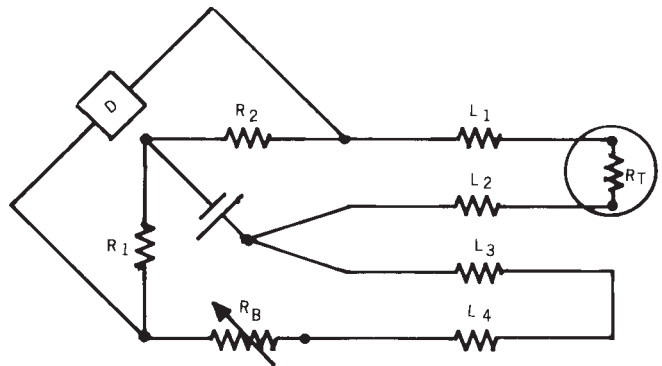
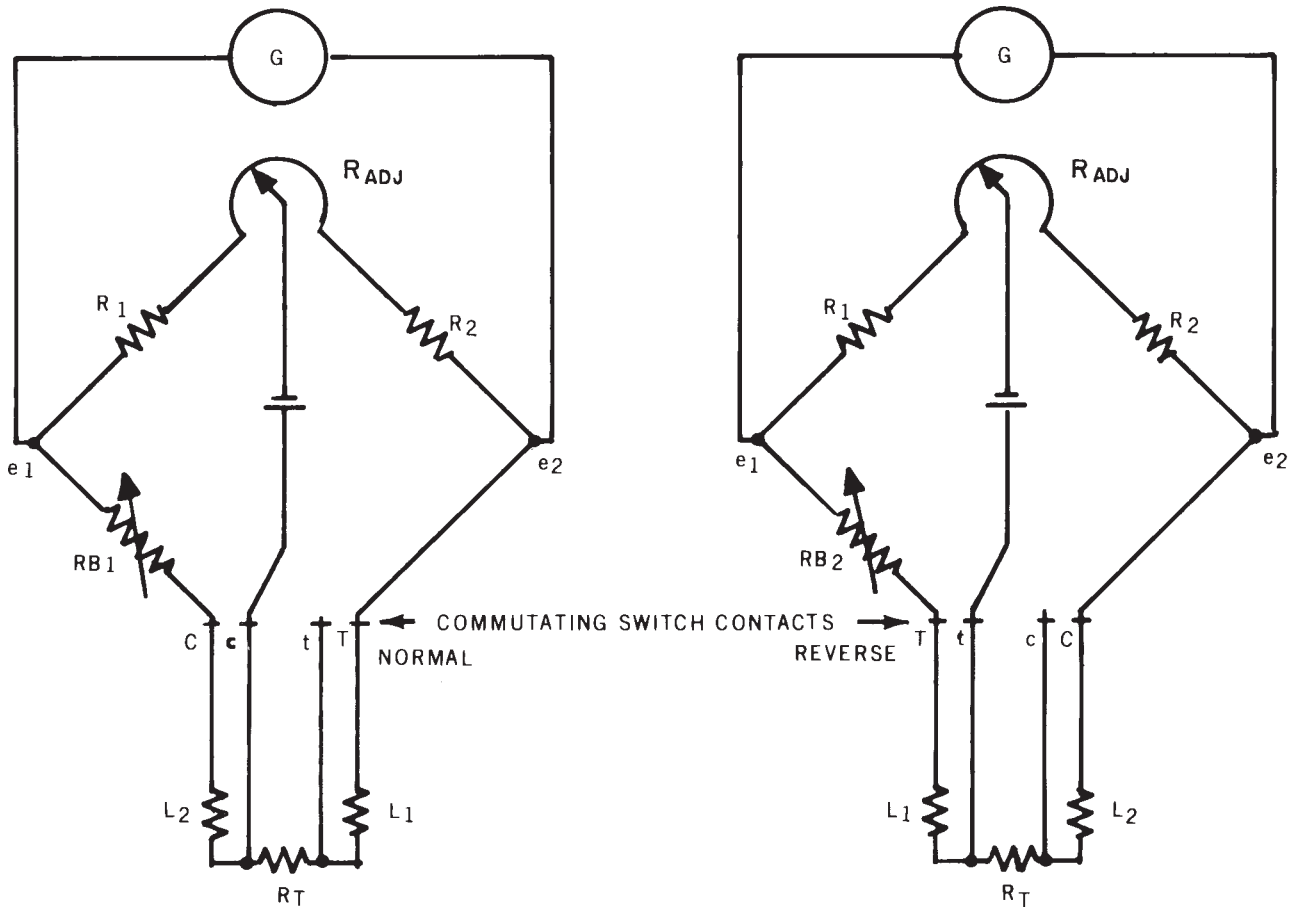

FIG. X2.5 Determination of the Resistance of a Compensated Four-Wire Thermometer Employing a Modified Bridge

hence:

$$R_T = (R_{B1} + R_{B2})/2 \quad (X2.18)$$



NOTE 1—Assumes that $L_1 = L_2$ or that the difference $(L_1 - L_2)$ is constant over the period of measurement.
FIG. X2.6 Determination of the Resistance of a Four-Terminal Thermometer Employing a Mueller Bridge

X3. POTENTIOMETER METHOD FOR RESISTANCE THERMOMETRY

X3.1 Fig. X3.1 shows a potentiometric circuit for determining the resistance of a four-terminal thermometer.

where:

- R_T = thermometer resistance to be determined.
- R_S = standard resistor of precisely known value.
- P = potentiometer or precisely known adjustable resistor
- G = null detector,
- I_1 = independent stable current in the unknown resistance circuit, and
- I_2 = independent stable current in the potentiometer circuit.

At balance.

$$I_1 R_T = I_2 P_T = V_T \tag{X3.1}$$

and

$$I_1 R_S = I_2 P_S = V_S \tag{X3.2}$$

where P_T and P_S are the averages of the forward and reverse current resistance settings of the potentiometer at voltage balance with the thermometer and standard resistor, respectively. V_T and V_S are the corresponding average voltages. Then:

$$R_T = R_S P_T/P_S = R_S V_T/V_S \tag{X3.3}$$

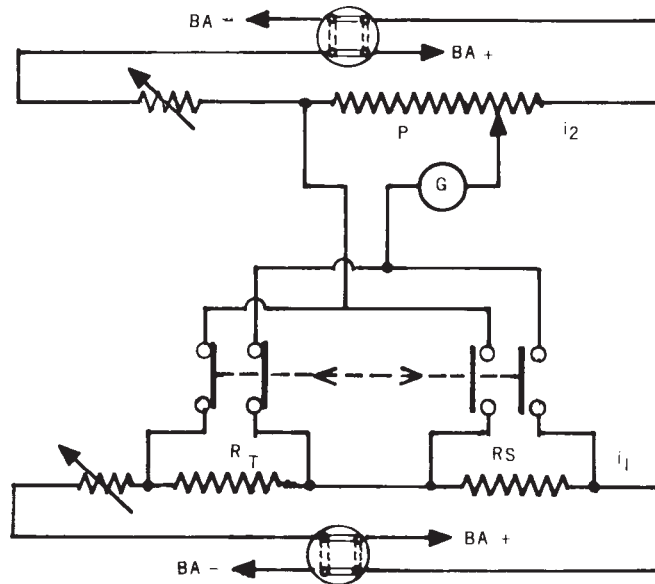

FIG. X3.1 Determination of the Resistance of a Four-Terminal Thermometer Employing a Potentiometric Method with Current Reversing Switches

X4. EXPECTED REPEATABILITY AND REPRODUCIBILITY OF THE TEST RESULTS

TABLE X4.1 Estimated Repeatability and Reproducibility of Test Results^A

NOTE 1—The repeatability and reproducibility of a measurement process are dependent upon the standards, measurement instruments, and associated equipment that are used and upon the experience and care exercised by the operator.

Test Temperature or Conditions	Repeatability	Reproducibility
At Ambient	5. Insulation Resistance ±5 %	±10 %
0.00 °C	6. Thermometer Calibration ±0.005 °C	±0.01 °C
0.01 °C	±0.001 °C	±0.002 °C
100 °C	±0.001 to ±0.01 °C	±0.002 to ±0.05 °C
232 °C	±0.001 to ±0.01 °C	±0.002 to ±0.05 °C
420 °C	±0.001 to ±0.01 °C	±0.002 to ±0.05 °C
of ±0.01 °C to ±0.1 °C uncertainty	7. Minimum Immersion Length ±5 mm	±10 mm
of 1 s to 30 s	9. Thermal Response Times ±5 %	±10 to ±15 %
at 0 °C	12. Self Heating Effect ±10 to ±20 %	±20 to ±30 %
Flowing water at 25 °C	±20 to ±30 %	±30 to ±40 %
at 100 °C	±20 to ±30 %	±30 to ±50 %
at 232 °C	±10 to ±20 %	±20 to ±50 %
at 420 °C	±10 to ±40 %	±20 to ±50 %
Calibration Temperature	14. Thermoelectric Effect ±1 μV	±1 μV

^A Estimated from RR-E20-1000 results.*

* Round-Robin Measurements with Platinum Resistance Thermometers, available from ASTM Headquarters. Request RR-E20-1000.

ASTM International takes no position respecting the validity of any patent rights asserted in connection with any item mentioned in this standard. Users of this standard are expressly advised that determination of the validity of any such patent rights, and the risk of infringement of such rights, are entirely their own responsibility.

This standard is subject to revision at any time by the responsible technical committee and must be reviewed every five years and if not revised, either reapproved or withdrawn. Your comments are invited either for revision of this standard or for additional standards and should be addressed to ASTM International Headquarters. Your comments will receive careful consideration at a meeting of the responsible technical committee, which you may attend. If you feel that your comments have not received a fair hearing you should make your views known to the ASTM Committee on Standards, at the address shown below.

This standard is copyrighted by ASTM International, 100 Barr Harbor Drive, PO Box C700, West Conshohocken, PA 19428-2959, United States. Individual reprints (single or multiple copies) of this standard may be obtained by contacting ASTM at the above address or at 610-832-9585 (phone), 610-832-9555 (fax), or service@astm.org (e-mail); or through the ASTM website (www.astm.org).