



Standard Specification for Thermistor Sensors for Clinical Laboratory Temperature Measurements¹

This standard is issued under the fixed designation E 879; the number immediately following the designation indicates the year of original adoption or, in the case of revision, the year of last revision. A number in parentheses indicates the year of last reapproval. A superscript epsilon (ϵ) indicates an editorial change since the last revision or reapproval.

1. Scope

1.1 This specification covers the general requirements for negative temperature coefficient thermistor-type sensors intended to be used for clinical laboratory temperature measurements or control, or both, within the range from -10 to 105°C .

1.2 This specification also covers the detailed requirements for ASTM designated sensors.

1.3 *This standard does not purport to address all of the safety concerns, if any, associated with its use. It is the responsibility of the user of this standard to establish appropriate safety and health practices and determine the applicability of regulatory limitations prior to use.*

2. Referenced Documents

2.1 ASTM Standards:

E 344 Terminology Relating to Thermometry and Hydrometry²

E 563 Practice for Preparation and Use of an Ice-Point Bath as a Reference Temperature²

F 29 Specification for Dumet Wire for Glass-to-Metal Seal Applications³

3. Terminology

3.1 *Definitions*—The definitions given in Terminology E 344 shall apply to this specification.

3.2 Definitions of Terms Specific to This Standard:

3.2.1 *dissipation constant, δ , n* —the ratio of the change in energy dissipated per unit time (power) in a thermistor, $\Delta \dot{Q} = \dot{Q}_2 - \dot{Q}_1$, to the resultant temperature change of the thermistor, $\Delta t = t_2 - t_1$.

$$\delta = \frac{\Delta \dot{Q}}{\Delta t} \quad (1)$$

The dimensions of the dissipation constant are W/K. For this specification, t_1 is in the range from 20 to 38°C and $\Delta t = 10^{\circ}\text{C}$.

3.2.2 *dumet, n* —round, copper-coated 42 % nickel-iron wire intended primarily for sealing to soft glass. Also known as

CuNiFe in some communities.

3.2.3 *insulation resistance, dc, n* —the resistance at a specified direct-current voltage between the insulated leads of a thermistor sensor and the metallic enclosure of the sensor, if such an enclosure is present, or else between the sensor leads and a conductive medium in which the sensor is immersed.

3.2.4 *qualification test, n* —a series of tests conducted by the procuring agency or an agent thereof to determine conformance of thermistor sensors to the requirements of a specification, normally for the development of a qualified products list under the specification.

3.2.5 *response time, n* —the time required for a sensor to change a specified percentage of the total difference between its initial and final temperatures as determined from zero-power resistances when the sensor is subjected to a step function change in temperature.

3.2.6 *time constant, n* —the 63.2 % response time of a sensor that exhibits a single-exponential response.

3.2.7 *zero-power resistance, n* —the dc resistance of a device, at a specified temperature, calculated for zero-power.

3.2.7.1 *Discussion*—Accurate zero-power resistance is obtained by extrapolating to zero-power the resistance values obtained from measurements at three or more levels of power with the sensor immersed in a constant temperature medium. For the purpose of this specification, this is obtained from measurements at a single power level adjusted such that the power is not greater than one-fifth the product of the dissipation constant specified in Table 1 (see 3.2.1 and 7.3) and the appropriate tolerance requirement of Table 2. When making stability measurements, the power shall be kept constant.

4. Classification

4.1 Thermistor sensors covered by this specification shall be classified with a type designation code that includes the ASTM detailed specification number followed by a descriptive code. See Fig. 1.

4.2 *ASTM Specification Number*—The ASTM specification number specifies uniquely the design and construction of the sensor including the type designation if more than one type appears in the same specification.

4.2.1 *Type Designation*—The type designation shall be a letter symbol to indicate the design and construction of the thermistor sensor.

4.2.1.1 *Type S*—Silicone rubber-coated glass probe with

¹ This specification is under the jurisdiction of ASTM Committee E20 on Temperature Measurement and is the direct responsibility of Subcommittee E20.08 on Medical Thermometry.

Current edition approved May 10, 2001. Published June 2001. Originally published as E 879 – 82. Last previous edition E 879 – 93.

² *Annual Book of ASTM Standards*, Vol 14.03.

³ *Annual Book of ASTM Standards*, Vol 10.04.

TABLE 1 Specification for ASTM Clinical Laboratory Thermistor Sensors

ASTM No.	E 879 S B1N	E 879 E B1N	E 879 S B2N	E 879 E B2N
Description	Silicone Rubber Coated Glass Probe	Epoxy Coated Glass Probe	Silicone Rubber Coated Glass Probe	Epoxy Coated Glass Probe
Major Application	General Purpose Clinical Laboratory Temperature Measurement	General Purpose Clinical Laboratory Temperature Measurement	General Purpose Clinical Laboratory Temperature Measurement	General Purpose Clinical Laboratory Temperature Measurement
Operating Temperature Range	-10 to 60°C	-10 to 60°C	-10 to 60°C	-10 to 60°C
Accuracy Class	1 ($\pm 0.01^\circ\text{C}$)	1 ($\pm 0.01^\circ\text{C}$)	2 ($\pm 0.02^\circ\text{C}$)	2 ($\pm 0.02^\circ\text{C}$)
Temperatures for Accuracy Class	-10 to 60°C	-10 to 60°C	-10 to 60°C	-10 to 60°C
Accuracies for other Temperatures Within Specified Temperature Range				
Calibration Type	Non-interchangeable	Non-interchangeable	Non-interchangeable	Non-interchangeable
Nominal <i>R-T</i> Characteristic				
$R = \exp[A_0 + A_1/T + A_2/T^2 + A_3/T^3]$ (<i>T</i> in kelvins)				
$T(^\circ\text{C}) = [a_0 + a_1 \ln R + a_2 (\ln R)^2 + a_3 (\ln R)^3]^{-1} - 273.15$				
A_0	-4.4495078	-4.4495078	-4.4495078	-4.4495078
A_1	3614.7764	3614.7764	3614.7764	3614.7764
A_2	88190.906	88190.906	88190.906	88190.906
A_3	-22328247	-22328247	-22328247	-22328247
a_0	$0.11766716 \times 10^{-2}$	$0.11766716 \times 10^{-2}$	$0.11766716 \times 10^{-2}$	$0.11766716 \times 10^{-2}$
a_1	$0.28173082 \times 10^{-3}$	$0.28173082 \times 10^{-3}$	$0.28173082 \times 10^{-3}$	$0.28173082 \times 10^{-3}$
a_2	$-0.23285292 \times 10^{-5}$	$-0.23285292 \times 10^{-5}$	$-0.23285292 \times 10^{-5}$	$-0.23285292 \times 10^{-5}$
a_3	$0.24131652 \times 10^{-6}$	$0.24131652 \times 10^{-6}$	$0.24131652 \times 10^{-6}$	$0.24131652 \times 10^{-6}$
Type of Immersion Fluid	water, air	water, oil, air	water, air	water, oil, air
Nominal R_0 at 25°C	2.5 $\kappa\Omega$	2.5 $\kappa\Omega$	2.5 $\kappa\Omega$	2.5 $\kappa\Omega$
Dissipation Constant	3.5 \pm 0.9 mW/K	5.0 \pm 1.2 mW/K	3.5 \pm 0.9 mW/K	5.0 \pm 1.2 mW/K
63.2 % Response Time	0.55 \pm 0.16 s	0.45 \pm 0.11 s	0.55 \pm 0.16 s	0.45 \pm 0.11 s
Ratio of 95 % to 63.2 % Response Times	2.5 \pm 0.6	2.1 \pm 0.5	2.5 \pm 0.6	2.1 \pm 0.5
Design and Construction	Fig. 2	Fig. 3	Fig. 2	Fig. 3
ASTM No.	E 879 S A2N	E 879 E A2N	E 879 G B1N	E 879 H B1N
Description	Silicone Rubber Coated Glass Probe	Epoxy Coated Glass Probe	5 $\kappa\Omega$ -4-Wire Non-interchangeable Sensor in S.S. Housing	5 $\kappa\Omega$ -2-Wire Non-interchangeable Sensor in S.S. Housing
Major Application	General Purpose Clinical Laboratory Temperature Measurement	General Purpose Clinical Laboratory Temperature Measurement	General Purpose Clinical Laboratory Temperature Measurement	General Purpose Clinical Laboratory Temperature Measurement
Operating Temperature Range	-10 to 105°C	-10 to 105°C	-10 to 60°C	-10 to 60°C
Accuracy Class	2 ($\pm 0.02^\circ\text{C}$)	2 ($\pm 0.02^\circ\text{C}$)	1 ($\pm 0.01^\circ\text{C}$)	1 ($\pm 0.01^\circ\text{C}$)
Temperatures for Accuracy Class	-10 to 105°C	-10 to 105°C	-10 to 60°C	-10 to 60°C
Accuracies for other Temperatures Within Specified Temperature Range				
Calibration Type	Non-interchangeable	Non-interchangeable	Non-interchangeable	Non-interchangeable
Nominal <i>R-T</i> Characteristic				
$R = \exp[A_0 + A_1/T + A_2/T^2 + A_3/T^3]$				
$T(^\circ\text{C}) = [a_0 + a_1 \ln R + a_2 (\ln R)^2 + a_3 (\ln R)^3]^{-1} - 273.15$				
A_0	-4.3332974	-4.3332947	-3.7563605	-3.7563605
A_1	4440.1603	4440.1603	3614.7764	3614.7764
A_2	-104525.78	-104525.78	88190.906	88190.906
A_3	-4581329.78	-4581329.78	-22328247	-22328247
a_0	$0.98667965 \times 10^{-3}$	$0.98667965 \times 10^{-3}$	$0.98019160 \times 10^{-3}$	$0.98019160 \times 10^{-3}$
a_1	$0.24329879 \times 10^{-3}$	$0.24329879 \times 10^{-3}$	$0.28530667 \times 10^{-3}$	$0.28530667 \times 10^{-3}$
a_2	$-0.59584872 \times 10^{-6}$	$-0.59584872 \times 10^{-6}$	$-0.28303328 \times 10^{-5}$	$-0.28303328 \times 10^{-5}$
a_3	$0.97166167 \times 10^{-7}$	$0.97166167 \times 10^{-7}$	$0.24131652 \times 10^{-6}$	$0.24131652 \times 10^{-6}$
Type of Immersion Fluid	water, air	water, air	all fluids compatible with Type 304 S.S.	all fluids compatible with Type 304 S.S.
R_0 at 25°C	10 $\kappa\Omega$	10 $\kappa\Omega$	5 $\kappa\Omega$	5 $\kappa\Omega$
Dissipation Constant	3.5 \pm 0.9 mW/K	5.0 \pm 1.2 mW/K	4.8 \pm 1.2 mW/K	4.8 \pm 1.2 mW/K
63.2 % Response Time	0.55 \pm 0.16 s	0.45 \pm 0.11 s	4.5 \pm 1.1 s	4.5 \pm 1.1 s
Ratio of 95 % to 63.2 % Response Times	2.5 \pm 0.6	2.1 \pm 0.5	2.6 \pm 0.3	2.6 \pm 0.3
Design and Construction	Fig. 2	Fig. 3	Fig. 4	Fig. 5

tinned Dumet extension leads (see Fig. 2).

 4.2.1.2 *Type E*—Epoxy-coated glass probe with silver-plated copper extension leads (see Fig. 3).

 4.2.1.3 *Type G*—General purpose four wire sensor in stainless steel housing (see Fig. 4).

TABLE 1 (continued)

ASTM No.	E 879 G B1N	E 879 H B1N	E 879 G A2N	E 879 H A2N
Description	10 $\kappa\Omega$ 4-Wire Non-interchangeable Sensor in S.S. Housing	10 $\kappa\Omega$ 2-Wire Non-interchangeable Sensor in S.S. Housing	10 $\kappa\Omega$ 4-Wire Non-interchangeable Sensor in S.S. Housing	10 $\kappa\Omega$ 2-Wire Non-interchangeable Sensor in S.S. Housing
Major Application	General Purpose Clinical Laboratory Temperature Measurement	General Purpose Clinical Laboratory Temperature Measurement	General Purpose Clinical Laboratory Temperature Measurement	General Purpose Clinical Laboratory Temperature Measurement
Operating Temperature Range	-10 to 60°C	-10 to 60°C	-10 to 105°C	-10 to 105°C
Accuracy Class	1 ($\pm 0.01^\circ\text{C}$)	1 ($\pm 0.01^\circ\text{C}$)	2 ($\pm 0.02^\circ\text{C}$)	2 ($\pm 0.02^\circ\text{C}$)
Temperatures for Accuracy Class	-10 to 60°C	-10 to 60°C	-10 to 105°C	-10 to 105°C
Accuracies for other Temperatures				
Within Specified Temperature Range				
Calibration Type	Non-interchangeable	Non-interchangeable	Non-interchangeable	Non-interchangeable
Nominal <i>R-T</i> Characteristic				
$R = \exp[A_0 + A_1/T + A_2/T^2 + A_3/T^3]$				
$T(^{\circ}\text{C}) = [a_0 + a_1 \ln R + a_2 (\ln R)^2 + a_3 (\ln R)^3]^{-1} - 273.15$				
A_0	-3.5684919	-3.5684919	-3.7191520	-3.7191520
A_1	3907.7065	3907.7065	4045.1666	4045.1666
A_2	33480.382	33480.382	-8181.7100	-8181.7100
A_3	-18666997	-18666997	-14472122	-14472122
a_0	$0.86972495 \times 10^{-3}$	$0.86972495 \times 10^{-3}$	$0.89898144 \times 10^{-3}$	$0.89898144 \times 10^{-3}$
a_1	$0.27135335 \times 10^{-3}$	$0.27135335 \times 10^{-3}$	$0.26152805 \times 10^{-3}$	$0.26152805 \times 10^{-3}$
a_2	$-0.20689100 \times 10^{-5}$	$-0.20689100 \times 10^{-5}$	$-0.97537969 \times 10^{-6}$	$-0.97537969 \times 10^{-6}$
a_3	$0.20547429 \times 10^{-6}$	$0.20547429 \times 10^{-6}$	$0.16613292 \times 10^{-6}$	$0.16613292 \times 10^{-6}$
Type of Immersion Fluid	all fluids compatible with Type 304 S.S.	all fluids compatible with Type 304 S.S.	all fluids compatible with Type 304 S.S.	all fluids compatible with Type 304 S.S.
Nominal R_0 at 25°C	10 $\kappa\Omega$	10 $\kappa\Omega$	10 $\kappa\Omega$	10 $\kappa\Omega$
Dissipation Constant	4.8 ± 1.2 mW/K	4.8 ± 1.2 mW/K	4.8 ± 1.2 mW/K	4.8 ± 1.2 mW/K
63.2 % Response Time	4.5 ± 1.1 s	4.5 ± 1.1 s	4.5 ± 1.1 s	4.5 ± 1.1 s
Ratio of 95 % to 63.2 % Response Times	2.6 ± 0.3	2.6 ± 0.3	2.6 ± 0.3	2.6 ± 0.3
Design and Construction	Fig. 4	Fig. 5	Fig. 4	Fig. 5
ASTM No.	E 879 V B3I	E 879 W B3N		
Description	Interchangeable Sensor Enclosed in 1.17 mm Plastic Tube	Non-interchangeable Sensor Enclosed in 0.92 mm Plastic Tube		
Major Application	Cuvette Thermometry	Cuvette Thermometry		
Operating Temperature Range	-10 to 60°C	-10 to 60°C		
Accuracy Class	3 ($\pm 0.05^\circ\text{C}$)	3 ($\pm 0.05^\circ\text{C}$)		
Temperatures for Accuracy Class	24 to 45°C	-10 to 60°C		
Accuracies for other Temperatures	-10 to 24°C: $\pm 0.1^\circ\text{C}$ 45 to 60°C: $\pm 0.1^\circ\text{C}$			
Within Specified Temperature Range				
Calibration Type	Interchangeable	Non-interchangeable		
Nominal <i>R-T</i> Characteristic				
$R = \exp[A_0 + A_1/T + A_2/T^2 + A_3/T^3]$				
$T(^{\circ}\text{C}) = [a_0 + a_1 \ln R + a_2 (\ln R)^2 + a_3 (\ln R)^3]^{-1} - 273.15$				
A_0	-3.1645305	-3.0612396		
A_1	3763.4399	3613.0051		
A_2	47816.278	88718.122		
A_3	-18332303	-22380305		
a_0	$0.78686094 \times 10^{-3}$	$0.78069589 \times 10^{-3}$		
a_1	$0.28128740 \times 10^{-3}$	$0.28967541 \times 10^{-3}$		
a_2	$-0.25226292 \times 10^{-5}$	$-0.38427027 \times 10^{-5}$		
a_3	$0.20852922 \times 10^{-6}$	$0.24169639 \times 10^{-6}$		
Type of Immersion Fluid	water	water		
Nominal R_0 at 25°C	11 $\kappa\Omega$	10 $\kappa\Omega$		
Dissipation Constant	1.1 ± 0.3 mW/K	0.8 ± 0.2 mW/K		
63.2 % Response Time	0.5 ± 0.12 s	0.26 ± 0.06 s		
Ratio of 95 % to 63.2 % Response Times	3.0 ± 0.3	3 ± 0.3		
Design and Construction	Fig. 6	Fig. 7		

TABLE 2 Equivalent Temperature Tolerances for Different Class Sensors (See 4.1 and 4.4)

Accuracy Class	Temperature Tolerance, °C
1	±0.02
2	±0.03
3	±0.05
4	±0.1

4.2.1.4 *Type H*—General purpose two-wire sensor in stainless steel housing (see Fig. 5).

4.2.1.5 *Type V*—Interchangeable sensor enclosed in 1.2-mm vinyl tube (see Fig. 6).

4.2.1.6 *Type W*—Non-interchangeable sensor enclosed in 0.9-mm vinyl tube (see Fig. 7).

4.3 *Operating Temperature Range*—The operating temperature range shall be designated by a letter symbol (see Table 3).

4.4 *Accuracy Class*—The accuracy class shall be designated by a single-digit number (see Table 2).

4.5 *Calibration Type*—The type of calibration required for each unit shall be designated by a letter symbol. The letter *I* shall be used to denote units that are interchangeable with respect to a single resistance-temperature relationship. The letter *N* shall be used to denote non-interchangeable units for which resistance-temperature information must be furnished for each unit. For Calibration Type N sensors, serial number identification must be provided.

5. Requirements

5.1 *Specifications*—Sensors shall comply with the general requirements specified herein as well as with the applicable detailed specifications of Table 1. In the event of conflict between this requirement paragraph and the detailed specification of Table 1, Figs. 2-7 the latter shall govern.

5.2 *Zero-Power Resistance versus Temperature Relationship*—The zero-power resistance versus temperature relationship shall be presented in a form such that any temperature within the specified operating temperature range can be obtained from that relationship and have an uncertainty no greater than one-tenth the specified tolerance in Table 2. When tested in accordance with 7.2, the zero-power resistance versus temperature relationship for interchangeable parts shall comply to within the tolerance specified in Table 2. The manufacturer of the sensor shall, for non-interchangeable parts, supply this relationship with each part shipped.

5.2.1 *Accuracy*—The resistance-temperature relationship, provided in Table 1, or with the sensor, or both, shall not differ from that obtained from measurements made in accordance with 7.2 by more than the tolerances specified in Table 2 for the applicable intervals specified in Table 1.

5.3 *Thermal Requirements:*

5.3.1 *Dissipation Constant*—When tested in accordance with 7.3, the dissipation constant shall be as specified in the detailed specification.

5.3.2 *Response Time*—When tested in accordance with 7.4, the response time or time constant, or both, shall be as specified in the detailed specification.

5.4 *Environmental Requirements:*

5.4.1 *Operating Temperature Range*—The operating tem-

perature range shall be as specified in the type designation code (see 4.1 and 4.3).

5.4.2 *Storage Temperature Range*—Sensors shall be capable of meeting all requirements specified herein as well as those listed in the applicable detailed specification after storage at any temperature (or combination thereof) in the range from -40 to 60°C for a period of 1 year.

5.4.3 *Humidity Requirement*—Sensors shall be capable of being operated or stored at relative humidity from 0 to 95 % without condensation.

5.5 *Stability:*

5.5.1 *Short-Term Stability* (10 days)—When tested in accordance with 7.5.1, the equivalent temperature shift shall be no greater than 10 % of the tolerance shown in Table 2 for the accuracy class specified.

5.5.2 *Long-Term Stability* (120 days)—When tested in accordance with 7.5.2, the equivalent temperature shift shall be no greater than 25 % of the tolerance shown in Table 2 for the accuracy class specified.

5.6 *Low-Temperature Storage*—When tested in accordance with 7.6, there shall be no evidence of mechanical damage and the sensor shall comply with the accuracy requirements of 5.2.

5.7 *Thermal Shock*—When tested in accordance with 7.7, there shall be no evidence of mechanical damage and the sensor shall comply with the accuracy requirements of 5.2.

5.8 *Insulation Resistance:*

5.8.1 *Dry Test*—This requirement shall apply to sensors that have exposed metallic surfaces, but are not designed for immersion in conductive fluids. When tested in accordance with 7.8.1, there shall be no evidence of mechanical damage and the insulation resistance shall be sufficiently high that its shunting effect will not prevent the unit from complying with the accuracy requirement of Table 2. In no case shall the insulation resistance be less than 10⁸ ohms.

5.8.2 *Wet Test*—This requirement shall apply to sensors that are designed for use in conductive solutions. When tested in accordance with 7.8.2, there shall be no evidence of mechanical damage and the insulation resistance shall be sufficiently high that its shunting effect will not prevent the unit from complying with the accuracy requirement of Table 2. In no case shall the insulation resistance be less than 10⁸ Ω.

6. Quality Assurance Provisions

6.1 *General*—The methods of examination and tests contained in Section 7 are to be used to determine the conformance of sensors to the requirements of this specification. Each manufacturer or distributor who represents his products as conforming to this specification may, as agreed upon between the purchaser and seller, use statistically based sampling plans that are appropriate for each inspection lot. Records shall be kept as necessary to document the claim that all of the requirements of this specification are met. The tests specified in this section are intended as minimum requirements. Additional sampling and testing of the product, as may be agreed upon between the purchaser and the seller, are not precluded by this section.

6.2 *Classification of Inspection:*

6.2.1 *Qualification Tests*—Qualification tests shall be performed for each basic design manufactured in accordance with

Example:

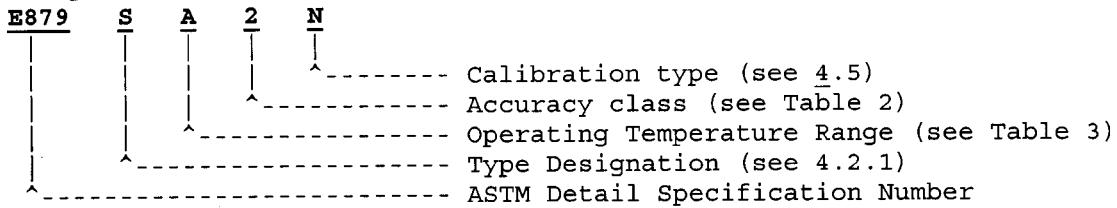
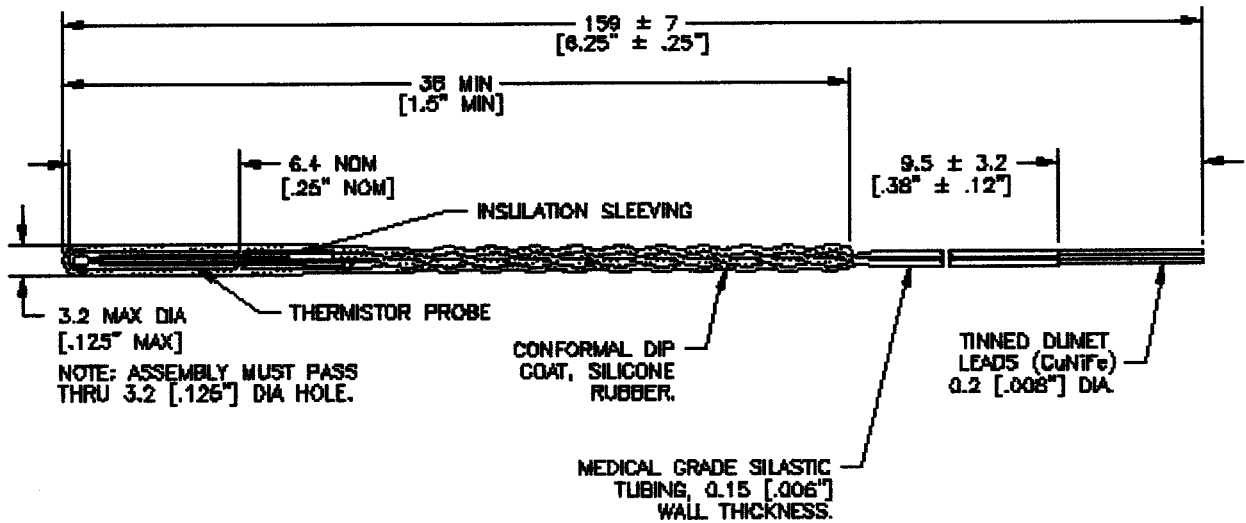
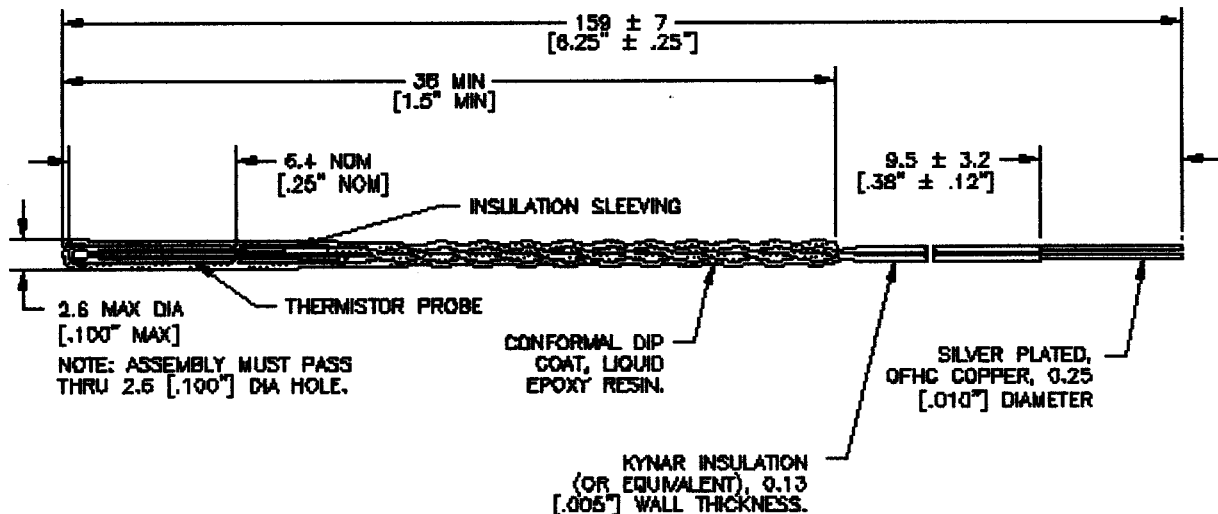

FIG. 1 Classification Code



NOTE: METRIC [ENGLISH] ALL DIMENSIONS IN MILLIMETRES UNLESS OTHERWISE INDICATED.

FIG. 2 Silicone Rubber Coated Glass Probe



NOTE: METRIC [ENGLISH] ALL DIMENSIONS IN MILLIMETRES UNLESS OTHERWISE INDICATED.

FIG. 3 Epoxy Coated Glass Probe

this specification. The sample size required for the tests conducted shall be in accordance with Table 4. In order for a design to qualify, there shall be no failures resulting from any of the tests.

6.2.2 *Responsibility for Qualification Testing*—The manufacturer shall perform qualification testing, at least once, for each basic design for which this specification applies. If a basic design incorporates more than one resistance value of a specific

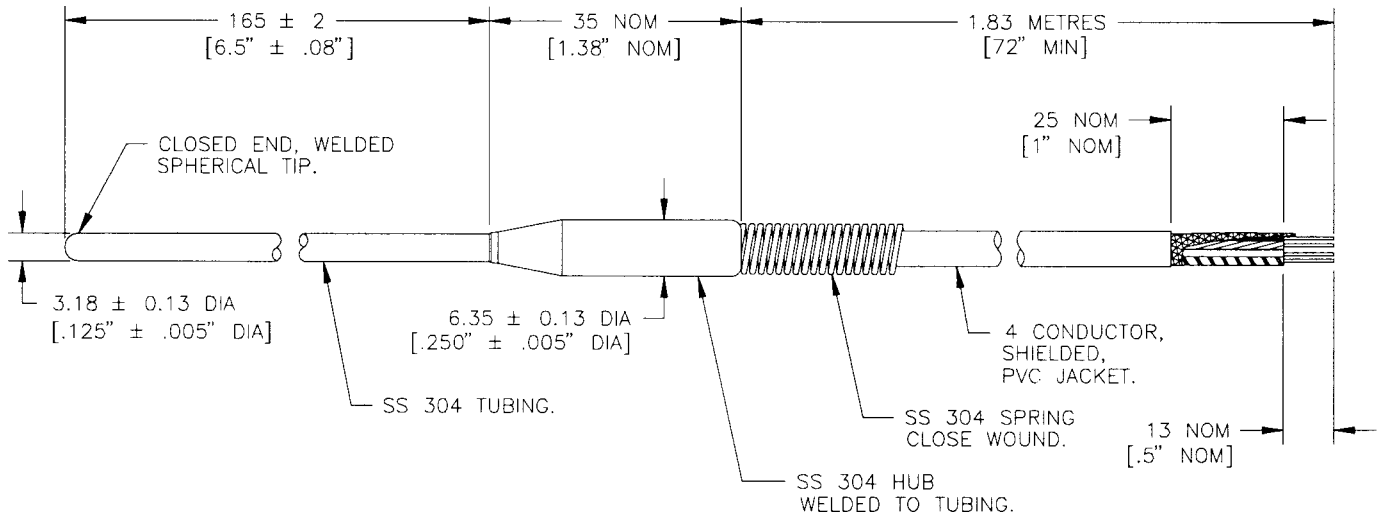

NOTE 1—Metric (English) All dimensions in millimetres unless otherwise indicated.
FIG. 4 General Purpose Four-Wire Sensor in Stainless Steel Housing

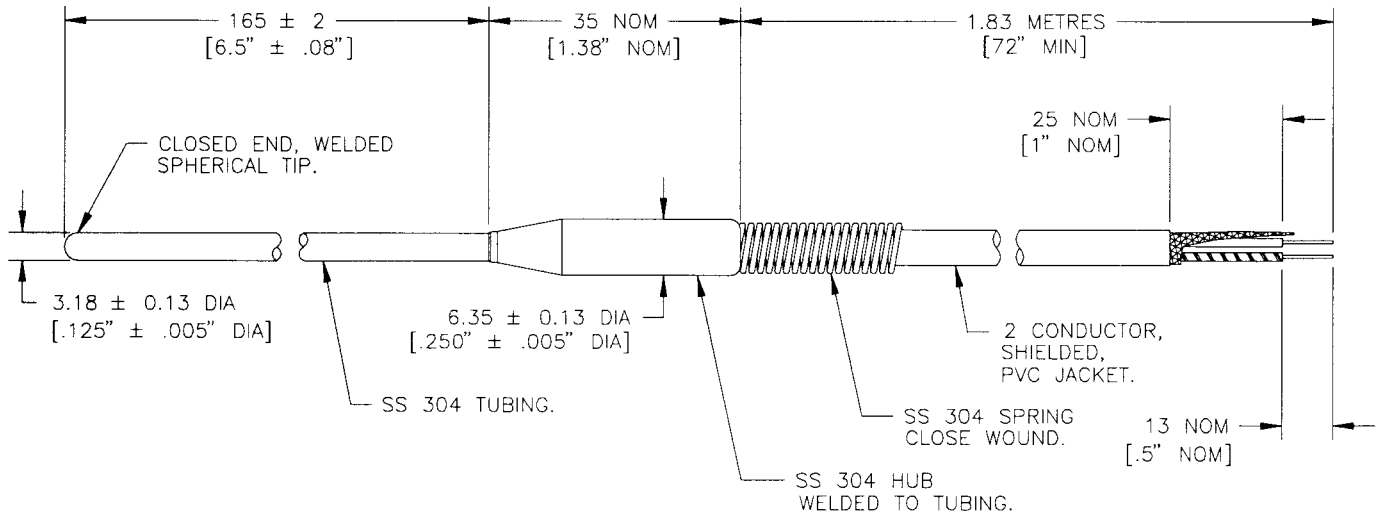

NOTE 1—Metric (English) All dimensions in millimetres unless otherwise indicated.
FIG. 5 General Purpose Two-Wire Sensor in Stainless Steel Housing

material formulation or a particular style of thermistor, or both, different resistance values may be combined for the qualification sample. The highest and lowest resistance values for a specified thermistor design (type, material formulation, and geometry) must be included in the qualification sample. Qualification testing, by the manufacturer, must be repeated whenever a design change is introduced which may affect the performance of the sensor with regard to Section 5 of this specification.

6.2.3 *Manufacturing Screening Tests*—During manufacture, all parts produced in accordance with this specification shall receive 100 % testing for compliance with the requirements of Table 5.

7. Methods of Examination and Test

7.1 *Visual and Mechanical Examination*—Examine sensors to verify that their design, construction, physical dimensions, markings, and workmanship comply with the detailed specification.

7.2 Zero-Power Resistance versus Temperature Relationship^{4,5,6}

7.2.1 *Traceability*—All measurements shall be traceable to the National Institute of Standards and Technology (NIST) through the use of suitable reference standards with documentation.

7.2.2 *Temperature-Controlled Medium*—Make all measurements in a temperature-controlled liquid bath (such as a water bath). The volume of the liquid should be at least 1000 times the volume of the sensor(s) under test, but shall not be less than 1 L. Baths having volumes as large as 100 L have been found to be convenient to use and to be satisfactory with respect to

⁴ Mangum, B. W., "Platinum Resistance Thermometer Calibration," *NBS Special Publication 250-22* (1987).

⁵ Mangum, B. W., and Furukawa, G. T., "Guidelines for Realizing the International Temperature Scale of 1990 (ITS-90) *NIST Technical Note 1265* (1990).

⁶ Riddle, J. L., Furukawa, G. T., and Plumb, H. H., "Platinum Resistance Thermometry," *NBS Monograph 126* (1973).

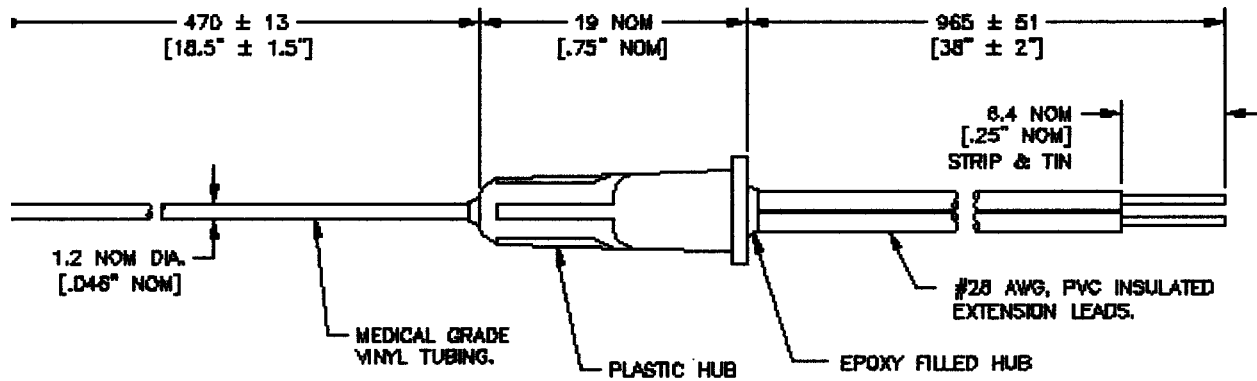

NOTE: METRIC [ENGLISH] ALL DIMENSIONS IN MILLIMETRES UNLESS OTHERWISE INDICATED.

FIG. 6 Interchangeable Sensor Enclosed in 1.2 mm Vinyl Tube (Type V)

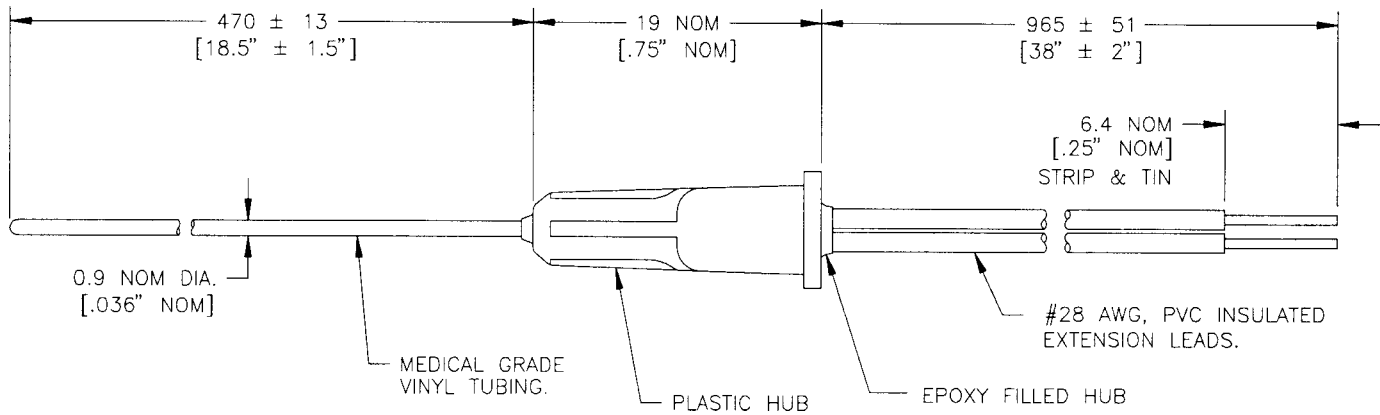

NOTE 1—Metric (English) All dimensions in millimetres unless otherwise indicated.

FIG. 7 Non-Interchangeable Sensor Enclosed in 0.9 mm Vinyl Tube

TABLE 3 Letter Symbol Designation of Operating Temperature Ranges (See 4.1 and 4.3)

Operating Temperature Range	Letter Symbol
-10 to 105°C	A
-10 to 60°C	B

temperature control. Ensure that the bath medium is sufficiently well-stirred that temperature gradients are small compared with the temperature accuracy required. Survey the bath with a thermometer to ensure that its temperature is uniform to the extent necessary to perform the tests. If the operating temperature range of the thermistor sensor includes the ice-point temperature, the water triple-point temperature, or the gallium melting-point temperature, then an ice-point bath, a water triple-point cell, or a gallium melting-point cell may be

TABLE 4 Qualification Tests Required for Each Basic Design

Examination or Test	Requirement Section(s)	Method Section(s)	Sample Size
Visual and mechanical	5.1	7.1	10
Zero-power resistance versus temperature relationship	5.2	7.2	10
Dissipation constant	5.3.1	7.3	5
Response time	5.3.2	7.4	5
Short-term stability	5.5.1	7.5.1	10
Long-term stability	5.5.2	7.5.2	10
Low-temperature storage	5.6	7.6	10
Thermal shock	5.7	7.7	10
Insulation resistance	5.8	7.8	10

used as the temperature-controlled medium at that respective temperature.

7.2.3 *Temperature Monitoring and Control*—Determine the temperature fluctuations of the bath with a thermometer having a response time that is shorter than or equal to that of the unit under test. The thermometer used to monitor the bath shall

TABLE 5 Manufacturing Screening Tests

Examination or Test	Requirement Section	Test Method Section
Visual and mechanical	5.1	7.1
Zero-power resistance versus temperature relationship	5.2	7.2
Insulation resistance	5.8	7.8

have a maximum uncertainty of one-third of the tolerance specified in Table 2. The total uncertainty resulting from the combined uncertainties of the monitor and the bath temperature (due to temperature fluctuations and bath gradients within the working volume) shall not be greater than one half of the tolerance specified in Table 2. When stability measurements are made in which the difference between two measurements must be considered, the total uncertainty shall not be greater than one third of the maximum difference allowed (see 5.5).

7.2.4 Resistance Measurement:

7.2.4.1 Accuracy:

(a) *Class 1 and Class 2 Sensors*—The uncertainty of the resistance measurement shall be less than $\pm 0.01\%$ for zero-power resistance determinations (see section 4.2.6) and less than $\pm 0.005\%$ for stability determinations.

(b) *Class 3 and Class 4 Sensors*—The uncertainty of the resistance measurement shall be less than $\pm 0.03\%$ for zero-power resistance determinations and less than $\pm 0.01\%$ for stability determinations.

7.2.5 Test Procedure:

7.2.5.1 *Temperature Stabilization*—After inserting the sensor into the bath, allow enough time for the sensor and bath to come to equilibrium (see 7.2.3).

7.2.5.2 *Immersion*—Best results will be obtained when measurements are made with the sensor totally immersed. The manufacturer shall specify the minimum immersion length required to obtain the specified tolerance within the temperature range permitted. (See Table 2.)

7.2.5.3 Zero-Power Resistance:

(a) *Sensors Designed to Operate in the Range from -10 to 60°C* —Determine the zero-power resistance of the sensor at $0 \pm 0.3^\circ\text{C}$, $30 \pm 0.3^\circ\text{C}$, and $60 \pm 0.5^\circ\text{C}$.

(b) *Sensors Designed to Operate in the Range from -10 to 105°C* —Determine the zero-power resistance of the sensor at $0 \pm 0.3^\circ\text{C}$, $30 \pm 0.3^\circ\text{C}$, $60 \pm 0.5^\circ\text{C}$, and $105 \pm 1.0^\circ\text{C}$.

7.3 *Dissipation Constant*—Determine the dissipation constant in water unless another fluid is specified. As determined here, the dissipation constant is for the specific environment described in 7.3.1. Measurements made with the sensor in air, oil, still water, etc. will yield different values.

7.3.1 Mount the sensor in a fluid bath that is controlled at some temperature, t_i , in the range from 24 to 38°C . The fluid specified for the bath shall have a velocity of no less than 1 m/s and its volume shall be no less than 1000 times the volume of the sensor. Determine the zero-power resistance, R_i , from measurements made in accordance with 7.2.

7.3.2 Increase the measuring current (or voltage) until the sensor indicates a resistance $R_i + 10$, equivalent to that at a temperature of $t_i + 10$, a temperature which is 10°C higher than that of the initial temperature t_i .

7.3.3 Measure the sensor current (or voltage) to within an

uncertainty of $\pm 1\%$ and compute the dissipation constant from Eq 2:

$$\delta = \frac{\Delta \dot{Q}}{\Delta t} = I^2 R_{i+10} / 10 = E^2 / 10 R_{i+10} \quad (2)$$

7.4 *Response Time*—Determine the response time in water unless another fluid is specified. As determined here, the response time is for the specific environment described in 7.4.2. Measurements made with the sensor in air, oil, still water, etc. will yield different values.

7.4.1 Connect the sensor to an instrument that continuously records the sensor output signal. It is desirable that the recorded signal be linearly related to temperature.

7.4.2 Mount the sensor in a *plunger-type* fixture above a fluid bath having a minimum volume of 1000 times the sensor volume and a temperature somewhere in the range from 0.01 to 5°C that is constant during the time of measurement. The fluid specified for the bath shall have a velocity of no less than 1 m/s.

7.4.3 Allow the sensor to come to equilibrium in air at room temperature.

7.4.4 Plunge the sensor into the bath to the immersion point specified in 7.2.5.2. (See Table 1 and Table 3.) The transit time between the start of the plunge and the submerged rest position of the sensor shall be less than 3% of the 90% thermal response time.

7.4.5 Observe the recording and determine the time required for the sensor to change from the initial to the final sensor temperature. Determine the 95% and 63.2% response times and calculate their ratio. If the ratio lies between 3.0 and 3.7 , then the sensor may be assumed to exhibit a single exponential response and the 63.2% response time may be considered to be the time constant of the sensor. If the ratio is greater than 3.7 , the 63.2% response time shall not be used as the time constant and the total response curve should be considered.

7.5 Stability:

7.5.1 Short-Term Stability:

7.5.1.1 *Class 1 and Class 2 Sensors*—Measurements in a Triple Point of Water Cell (as described in NBS Monograph 126) or a Gallium Melting Point Standard (National Institute of Standards and Technology SRM 1968 or commercially available equivalent) are required for testing the short-term stability of Class 1 and Class 2 sensors. Its use is optional for Class 3 and Class 4 sensors.

(a) Determine the zero-power resistance, R_m , in one of the above mentioned cells at a measurement temperature, t_m .

(b) Store the sensor, with no power applied, at its maximum rated temperature for a minimum period of 10 days.

(c) Repeat Step (a) at the same temperature.

(d) Compute $\Delta R_m / R_m$.

(e) Compute the equivalent temperature shift in accordance with 7.5.3.

7.5.1.2 *Class 3 and Class 4 Sensors*—The use of either an ice bath (See Practice E 563 for preparation of ice bath) or a temperature-controlled bath is optional for testing Class 3 and Class 4 sensors.

(a) Determine the zero-power resistance of the sensor in accordance with 7.2 at the ice point or some temperature in the range from 23 to 38°C .

(b) Store the sensor, with no power applied, at its maximum rated temperature for a minimum period of 10 days.

(c) Repeat step (a) at the same temperature.

(d) Compute $\Delta R_{tm}/R_{tm}$.

(e) Compute the equivalent temperature shift in accordance with 7.5.3.

7.5.2 Long-Term Stability:

7.5.2.1 Determine the zero-power resistance of the sensor in accordance with 7.2 at a measurement temperature, t_m , corresponding to the ice point, triple point of water, gallium melting point (see 7.5.1), or some temperature in the range from 23 to 38°C.

7.5.2.2 Store the sensor, with no power applied, at its maximum rated temperature for a minimum period of 120 days.

7.5.2.3 Repeat the step outlined in 7.5.2.1 at the same temperature.

7.5.2.4 Compute $\Delta R_{tm}/R_{tm}$.

7.5.2.5 Compute the equivalent temperature shift in accordance with 7.5.3.

7.5.3 Computation of Equivalent Temperature Shift—Although it may not always be valid for evaluation purposes, the assumption is made that the stability of a thermistor may be characterized by a fractional change in its zero-power resistance, which is dependent on time and maximum storage temperature but independent of the temperature at which the change is evaluated.

7.5.3.1 Sensors That Include 37°C Within Their Operating Ranges—Compute the equivalent temperature shift at 37°C from Eq 3:

$$\delta T = |R_{37}(\Delta R_{tm}/R_{tm})/5(R_{36.9} - R_{37.1})| \quad (3)$$

7.5.3.2 Sensors That Do Not Include 37°C Within Their Operating Ranges—Compute the equivalent temperature shift from Eq 4 at a temperature, t_s , which is the operating temperature closest to 37°C.

$$\delta T = |R_{ts}(\Delta R_{tm}/R_{tm})/5(R_{ts-0.1} - R_{ts+0.1})| \quad (4)$$

7.6 Low-Temperature Storage:

7.6.1 Determine the zero-power resistance versus temperature relationship in accordance with 7.2. If the results of a set of measurements made within 500 h of the low-temperature exposure exist, then this step may be eliminated.

7.6.2 Place the sensor in a chamber (whose volume and mass are at least 1000 times the volume and mass of the sensor) at room temperature.

7.6.3 Reduce the chamber temperature until the chamber is controlled at $-65 \pm 5^\circ\text{C}$. Allow the sensor to remain at this temperature for a period of 6 h \pm 15 min.

7.6.4 Remove the sensor from the chamber and allow it to stabilize at room temperature for not less than 1 h.

7.6.5 Determine the zero-power resistance versus temperature relationship in accordance with 7.2 and verify that it complies with the accuracy requirement of Table 1.

7.6.6 Examine the sensor for evidence of mechanical damage.

7.7 Thermal Shock:

7.7.1 Determine the zero-power resistance versus temperature relationship in accordance with 7.2 to ascertain if the

sensor complies with 5.2.1. This step may be omitted if the measurements were made within 500 h of the thermal shock exposure.

7.7.2 Plunge the sensor into an ice bath and allow it to come to equilibrium. Leave the sensor in the bath for a period of not less than ten times the thermal time constant.

7.7.3 Remove the sensor from the bath and allow at least 15 min for it to come to equilibrium at room temperature.

7.7.4 Plunge the sensor into a water bath set to control at either 55 to 60°C or 95 to 100°C depending upon the rating of the sensor. Allow a period of not less than ten times the thermal time constant for the sensor to reach equilibrium.

7.7.5 Remove the sensor from the bath and allow at least 15 min for it to come to equilibrium at room temperature.

7.7.6 Repeat Steps 7.7.2-7.7.5 for a total of five cycles.

7.7.7 Examine the sensor for evidence of mechanical damage.

7.7.8 Determine the zero-power resistance versus temperature relationship in accordance with 7.2 and verify that it complies with the accuracy requirement of Table 1.

7.8 Insulation Resistance:

7.8.1 Dry Test—Perform this test on sensors that have exposed metallic surfaces but are not designed for immersion in a conductive solution.

7.8.1.1 The insulation resistance shall be measured by applying 100 V dc between the insulated leads connected together and the exposed metallic surface of the sensor.

7.8.1.2 Repeat Step 7.8.1.1 with the polarity reversed.

7.8.1.3 Examine the sensor for evidence of mechanical damage.

7.8.1.4 Verify that the measured value of insulation resistance is greater than 10^8 ohms.

7.8.1.5 Using the zero power resistance versus temperature relationship specified or provided with the sensor,

(a) (a) Determine the zero-power resistance at the lowest temperature specified in Table 1.

(b) (b) Determine the value of zero-power resistance resulting from the shunting effect of the insulation resistance, R_s , from Eq 5.

$$R_s = R_{tL}R_f/(R_{tL} + R_f) \quad (5)$$

where R_s is the shunted value of the sensor, R_{tL} is the zero power resistance at the lowest temperature, t_L specified in Table 1 and R_f is the insulation resistance measured in 7.8.1.1.

(c) Determine the value of t_s , corresponding to the value of R_s computed from Eq 5, using the zero-power resistance versus temperature relationship for the sensor.

(d) Verify that the absolute value of $t_s - t_L$ does not exceed the tolerance specified in Table 2 for the accuracy class specified Table 1.

7.8.2 Wet Test—Perform this test on sensors that are designed for immersion in a conductive solution.

7.8.2.1 Immerse the sensor in a saturated water solution of sodium chloride for a period of not less than 24 h. The immersion depth shall be the same as that used in 7.2.

7.8.2.2 While the sensor is immersed, connect its leads together and measure the insulation resistance between the sensor leads and the solution with 100 V dc applied, unless otherwise specified in the detail specification.

7.8.2.3 Repeat Step 7.8.2.2 with the polarity reversed.

7.8.2.4 Examine the sensors for evidence of mechanical damage.

7.8.2.5 Verify that the measured value of insulation resistance is greater than 10^8 ohms.

7.8.2.6 Using the zero-power resistance versus temperature relationship specified or provided with the sensor,

(a) Determine the zero-power resistance at the lowest temperature specified in Table 1.

(b) Determine the value of zero-power resistance resulting from the shunting effect of the insulation resistance, R_s , from Eq 6.

$$R_s = R_{iL}R_f/(R_{iL} + R_f) \quad (6)$$

where R_s is the shunted value of the sensor, R_{iL} is the zero-power resistance at the lowest temperature, t_L specified in Table 1 and R_f is the insulation resistance measured in 7.8.1.1.

(c) Determine the value of t_s , corresponding to the value of R_s computed from Eq 5, using the zero-power resistance versus temperature relationship for the sensor.

(d) Verify that the absolute value of $t_s - t_L$ does not exceed the tolerance specified in Table 2 for the accuracy class specified in Table 1.

8. Keywords

8.1 clinical; laboratory; sensor; temperature; thermistor

The American Society for Testing and Materials takes no position respecting the validity of any patent rights asserted in connection with any item mentioned in this standard. Users of this standard are expressly advised that determination of the validity of any such patent rights, and the risk of infringement of such rights, are entirely their own responsibility.

This standard is subject to revision at any time by the responsible technical committee and must be reviewed every five years and if not revised, either reapproved or withdrawn. Your comments are invited either for revision of this standard or for additional standards and should be addressed to ASTM Headquarters. Your comments will receive careful consideration at a meeting of the responsible technical committee, which you may attend. If you feel that your comments have not received a fair hearing you should make your views known to the ASTM Committee on Standards, at the address shown below.

This standard is copyrighted by ASTM, 100 Barr Harbor Drive, PO Box C700, West Conshohocken, PA 19428-2959, United States. Individual reprints (single or multiple copies) of this standard may be obtained by contacting ASTM at the above address or at 610-832-9585 (phone), 610-832-9555 (fax), or service@astm.org (e-mail); or through the ASTM website (www.astm.org).