



Standard Test Method for Measurement of Viscosity of Glass Between 10^4 Pa·s and 10^8 Pa·s by Viscous Compression of a Solid Right Cylinder [Metric]¹

This standard is issued under the fixed designation C 1351M; the number immediately following the designation indicates the year of original adoption or, in the case of revision, the year of last revision. A number in parentheses indicates the year of last reappraisal. A superscript epsilon (ϵ) indicates an editorial change since the last revision or reappraisal.

1. Scope

1.1 This test method covers the determination of the viscosity of glass from 10^4 Pa·s to 10^8 Pa·s by measuring the rate of viscous compression of a small, solid cylinder.²

1.2 The values stated in SI units are to be regarded as the standard.

1.3 *This standard does not purport to address all of the safety concerns, if any, associated with its use. It is the responsibility of the user of this standard to establish appropriate safety and health practices and determine the applicability of regulatory limitations prior to use.*

2. Referenced Documents

2.1 ASTM Standards:

C 338 Test Method for the Softening Point of Glass³

C 965 Practice for Measuring Viscosity of Glass Above the Softening Point³

C 1350M Test Method for Measurement of Viscosity of Glass between the Softening Point and the Annealing Range (Approximately 10^8 Pa·s to 10^{13} Pa·s) by Beam Bending³

3. Terminology

3.1 *parallel plate viscometer*—a device used to determine the viscosity of glass from approximately 10^4 Pa·s to 10^8 Pa·s by measuring the rate of change in thickness of a cylindrical specimen between parallel plates moving perpendicular to their common central axis. The equation for calculating viscosity by the parallel plate method is:

$$\eta = 2\pi \frac{Mgh^5}{30V(dh/dt)(2\pi h^3 + V)(1 + \alpha T)} \quad (1)$$

¹ This test method is under the jurisdiction of ASTM Committee C-14 on Glass and Glass Products and is the direct responsibility of Subcommittee C14.04 on Physical and Mechanical Properties.

Current edition approved Oct. 10, 1996. Published December 1996.

² Fontana, E. H., "A Versatile Parallel-Plate Viscometer For Glass Viscosity Measurements to 1000°C", *Bulletin of the American Ceramic Society*, Vol 49, No. 6, 1970, pp. 594–597.

³ *Annual Book of ASTM Standards*, Vol 15.02.

where:

η = viscosity, Pa·s,
 M = applied load, g,
 g = acceleration due to gravity, 980 cm/s²,
 t = time, s,
 V = specimen volume, cm³,
 h = specimen thickness at time t , cm,
 dh/dt = compression rate, cm/s, and
 α = glass mean coefficient of thermal expansion, 25°C to the measurement temperature, T , m/m/°C. See Note 1.

NOTE 1—The term $(1 + \alpha T)$ corrects for the specimen dimensional changes due to thermal expansion. For low thermal expansion glasses, it can be ignored. However, for a glass with an α of $20 \times 10^{-6}/^\circ\text{C}$ at a measurement temperature of 1000°C, this term produces a correction of 2%. Only an estimate of α is necessary since the correction is small. Use twice the room temperature coefficient if data are unavailable.

4. Significance and Use

4.1 This test method is well suited for measuring the viscosity of glasses between the range within which rotational viscometry (see Practice C 965) is useful and the range within which beam bending viscometry is useful (see Test Method C 1350M). It can be used to determine the viscosity/temperature curve in the region near the softening point (see Test Method C 338). This test method is useful for providing information related to the behavior of glass as it is formed into an object of commerce, and in research and development.

5. Apparatus

5.1 The apparatus shall consist of a furnace, a means of controlling and measuring its temperature and heating rate, specimen holders and loading rod, and a means of measuring the rate of viscous compression of the glass specimen.

5.2 Furnace:

5.2.1 The furnace shall be electrically heated by resistance elements. The dimensions and details of the furnace construction are not critical; its cross-section can be circular of 75 mm (≈ 3 in.) diameter or square of sides of 75 mm. The furnace should have a constant temperature zone that covers the specimen geometry, including the compression range. Differences in temperature greater than 2°C within the constant

temperature zone are unacceptable.

5.3 *Temperature Measuring and Indicating Instruments:*

5.3.1 For the measurement of temperature, there shall be provided a calibrated Type K, R, or S thermocouple. The thermocouple shall be housed in a double-bore alumina tube with its junction placed within 5 mm of the specimen near the axis of the furnace. The thermocouple shall be referenced to 0°C by means of an ice bath, and its emf measured with a calibrated potentiometer that can be read with a sensitivity equivalent to $\pm 0.1^\circ\text{C}$ and an accuracy of $\pm 0.5^\circ\text{C}$. Precautions shall be taken to ensure that the ice bath is maintained at 0°C throughout the test. Alternately, the output of the thermocouple can be measured on a calibrated, direct reading meter (electronic thermometer) that can be read with a sensitivity of $\pm 0.1^\circ\text{C}$ and an accuracy of $\pm 0.5^\circ\text{C}$. See Note 3 for temperature lag-lead corrections.

5.4 *Furnace Control:*

5.4.1 Suitable means shall be provided for maintaining the furnace at a fixed control point and for controlling the heating and cooling rates. Commercially available programming equipment provides excellent control. A variable transformer with manual control is an inexpensive, but less adequate means of accomplishing the required control.

5.5 *Specimen Holder and Loading Rod:*

5.5.1 A typical configuration is presented in Fig. 1. Positioned horizontally on top of the support stand is a stationary

plate (see Note 2), 6 mm ($\sim 1/4$ in.) thick by diameter of the support stand. A movable plate, 6 mm thick by 44 mm minimum diameter is placed parallel and concentrically above the fixed plate. (See parallel plates in Fig. 1.) Attached to the top center of the movable plate in a shrink fit configuration is a 9-mm ($\sim 3/8$ -in.) diameter centerless-ground alumina rod of length sufficient to reach approximately 150 mm (6 in.) beyond the top of the furnace or its supporting structure, or both. This assembly provides a means for loading the specimen during measurement. Bushings attached to the external frame guide the shaft with a minimum amount of friction.

NOTE 2—Alumina and vitreous silica are suitable materials for the assembly components, as are noble or low expansion metals used in pairs. The user must observe temperature limitations for these alternate materials.

5.6 *Extensometer for Measuring Thickness Change:*

5.6.1 The means of observing the rate of thickness change of the specimen should allow reliable reading of total change of at least 6 mm. The extensometer shall permit direct reading of 0.010 mm and estimates of 0.001 mm. Its accuracy shall be such that the error of indication will not exceed $\pm 2\%$ for any measured translation. This will limit the minimum translation that may be used in calculation. A linearly variable differential transformer (LVDT) is suitable for this purpose, as is any other device (for example, optical or capacitive), provided that length changes are reliably measured as specified.

5.7 *Micrometer Calipers:*

5.7.1 Micrometer calipers, which can be read to an accuracy of at least 0.01 mm are required for measuring specimen dimensions.

6. **Preparation of Test Specimen**

6.1 Specimens required for this test method are small, right, circular cylinders. Nominal dimensions are 6 mm ($\sim 1/4$ in.) to 12 mm ($\sim 1/2$ in.) diameter and 3 to 6 mm thick. Specimens can be either core-drilled from flat stock or sliced from a rod. In both cases, the flat surfaces must be ground and polished to be plane-parallel to ± 0.001 mm. Cylinders made by dry pressing of frit at high pressure can provide meaningful data.

7. **Calibration**

7.1 Direct calibration of the apparatus is accomplished by using standard glasses, such as those supplied and certified by the National Institute of Standards and Technology (NIST), having known viscosity/temperature values.⁴ Bias should be corrected by overall instrument calibration.

7.1.1 Determine the viscosity using test cylinders of calibrating glasses which cover a range of cross-sections expected to be used for routine testing. Determine the viscosity by following the standard procedure described in Sections 8 and 7.

7.1.2 Mathematically fit resulting data to a convenient form (for example, polynomial or Fulcher⁵ equation). Fit the data supplied for the glass SRM to a Fulcher equation.

⁴ Table 2, *Annual Book of ASTM Standards*, Vol 15.01, NIST Special Publication No. 260.

⁵ Fulcher, G. S., *Journal of the American Ceramic Society*, Vol 8, 1925, pp. 339-355.

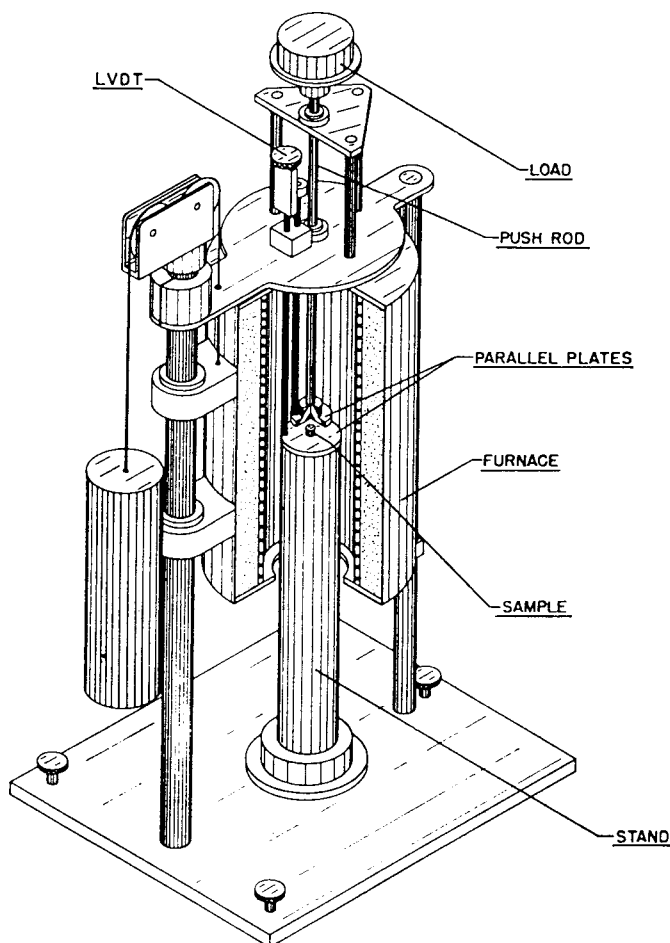

FIG. 1 A Typical Parallel Plate Viscometer

7.1.3 Calculate the viscosities from both equations determined in 7.1.2 at 20°C minimum intervals over the measured range. Determine the viscosity ratio, $\eta_{\text{SRM fit}}/\eta_{\text{measured fit}}$ = fractional correction, and construct a calibration curve of fractional correction versus log viscosity (measured fit). This is used to correct experimental viscosity data. (See Note 3.) Corrections greater than 20 % are cause for concern and should initiate apparatus troubleshooting.

NOTE 3—If analyses are performed under some heating or cooling rate time-temperature function, the thermocouple temperature may lag or lead the actual sample temperature. If thermocouple lag or lead does occur, the calibration curve described in 7.1.3 would incorporate this temperature bias as well as any viscosity bias. To assess whether thermocouple lag or lead exists, viscosities for a glass SRM may be measured under isothermal conditions at several temperatures. Compare temperatures at equivalent viscosity levels from the analysis of the same glass SRM measured under the heating or cooling rate condition. Temperature differences indicate thermocouple lag or lead. The difference should be applied as a temperature correction to measured temperatures prior to generating the calibration curve (7.1.3) or applying the calibration correction to test data (Section 9).

8. Procedure

8.1 Deflection data may be taken either under isothermal conditions or heating at a controlled rate not to exceed 5°C/min.

8.2 Identify the time-temperature function (for example, 5°C/min heating rate) to be used in the test. Generate a curve of background deflection against temperature by performing a measurement with the upper loading plate in contact with the lower support plate (pieces of platinum foil may be used for separation) while operating the furnace under the chosen time-temperature function. The thickness change of the test specimen is determined by algebraic subtraction of this background curve from the measured curve.

8.3 Measure the specimen diameter and thickness with a micrometer to within 0.01 mm and record the results.

8.4 To protect the parallel plates from reaction with the specimen, sandwich the specimen between two platinum foil pieces and place the sandwich concentrically between the parallel plates. All platinum foil must be the same thickness and suitably thin (preferably 25 µm thick) so as to allow seating of the components in their required position.

8.5 Adjust the position of the extensometer to the lower end of its measuring range. Place the furnace in position and start the chosen time-temperature function.

8.6 When a usable deflection rate is reached, begin recording extensometer, time and temperature data to be used in data reduction. The collection interval should not exceed 1 min. Suitable means of accumulating data include computer-controlled data acquisition or plotting the thickness change and temperature of the specimen with a two pen recorder operating on a convenient time base. (If such a recording device is not available and data must be taken manually, the thickness change and temperature may be recorded by taking readings of both the extensometer and temperature alternately at 30-s

intervals so that each will be read at 1-min. intervals. Because it is less accurate than the other methods, the user is discouraged from using this method to acquire data.) If the extensometer goes off range during the test, reset it. Compression of the sample to a thickness less than 1 mm is excessive.

9. Calculation

9.1 Use the corrected change in extensometer readings, dh , during a given time interval, dt , as the rate of thickness change, dh/dt , at the temperature corresponding to the middle of that interval. Also record the specimen thickness change, d , at the midpoint of the time interval; use it to calculate the specimen thickness:

$$h = h_0 - d \quad (2)$$

where:

h_0 = the initial specimen thickness.

Substitute those data into Eq 1 to calculate the viscosity, η . Correct the viscosity using the calibration curve (see Section 7) by multiplying the viscosity by the fractional correction factor corresponding to that viscosity.

10. Report

10.1 *At a minimum, report the following information:*

- 10.1.1 Identification of the glass tested,
- 10.1.2 Manufacturing source and date,
- 10.1.3 Calibration reference,
- 10.1.4 Temperature and viscosity points,
- 10.1.5 Date of test and name of operator, and
- 10.1.6 Other observations (for example, sample crystallized during measurement).

11. Precision and Bias

11.1 *Precision*—In the absence of round robin testing, a specific precision statement cannot be made. However, Fontana's paper² describing the parallel plate method can be used to provide insight into the precision and bias of the test method. Precision can be estimated from the data scatter in mathematical curve fitting of data.

11.2 *Bias*—In general, this procedure should yield values for viscosity points to $\pm 10\%$ of referenced SRM values. Systematic departures may occur for values obtained near the beginning and end of the determination where the thickness change rates are small. A rigid test of the apparatus is to calibrate with one NIST SRM glass and then measure other NIST SRM glasses based on this calibration. If the other standard glass values are within 4°C of certification, satisfactory performance has been established. If errors arise that increase or decrease with viscosity, a temperature measurement problem may exist or thermal gradients in the furnace may be too large. These should be corrected.

12. Keywords

- 12.1 glass; parallel plate; viscosity

 **C 1351M**

The American Society for Testing and Materials takes no position respecting the validity of any patent rights asserted in connection with any item mentioned in this standard. Users of this standard are expressly advised that determination of the validity of any such patent rights, and the risk of infringement of such rights, are entirely their own responsibility.

This standard is subject to revision at any time by the responsible technical committee and must be reviewed every five years and if not revised, either reapproved or withdrawn. Your comments are invited either for revision of this standard or for additional standards and should be addressed to ASTM Headquarters. Your comments will receive careful consideration at a meeting of the responsible technical committee, which you may attend. If you feel that your comments have not received a fair hearing you should make your views known to the ASTM Committee on Standards, 100 Barr Harbor Drive, West Conshohocken, PA 19428.