



Standard Test Method for Density of Glass by the Sink-Float Comparator¹

This standard is issued under the fixed designation C 729; the number immediately following the designation indicates the year of original adoption or, in the case of revision, the year of last revision. A number in parentheses indicates the year of last reapproval. A superscript epsilon (ϵ) indicates an editorial change since the last revision or reapproval.

^{ε1} NOTE—Section 11 was added editorially in April 1995.

1. Scope

1.1 This test method covers the determination of the density of glass or nonporous solids of density from 1.1 to 3.3 g/cm³. It can be used to determine the apparent density of ceramics or solids, preferably of known porosity.

1.2 *This standard does not purport to address all of the safety concerns, if any, associated with its use. It is the responsibility of the user of this standard to establish appropriate safety and health practices and determine the applicability of regulatory limitations prior to use.*

2. Referenced Documents

2.1 ASTM Standards:

- C 693 Test Method for Density of Glass by Buoyancy²
- D 1217 Test Method for Density and Relative Density (Specific Gravity) of Liquids by Bingham Pycnometer³
- E 12 Terminology Relating to Density and Specific Gravity of Solids, Liquids, and Gases⁴
- E 29 Practice for Using Significant Digits in Test Data to Determine Conformance with Specification⁵
- E 77 Test Method for Inspection and Verification of Thermometers⁶
- F 77 Test Method for Apparent Density of Ceramics for Electron Device and Semiconductor Application²

3. Summary of Method

3.1 The specimen of unknown density is compared with a reference standard of known density. The specimen to be measured is placed in a test tube containing a solution whose density at 35°C is within 0.0200 g/cm³ of the density of the specimen at 25°C. The solution is prepared using miscible liquids of known densities bracketing the desired range. The tube also contains a glass density reference standard whose density at 35°C is close to that of the solution at 35°C; the tube

is immersed in a variable-temperature comparator bath. Initially the solutions, specimen, and standard are at a temperature near 25°C, and both the standard and the specimen float in the solution. The temperature of the system is raised at a uniform rate. Because the expansion coefficient of the solution is higher than that of the glass standard and specimen, both the standard and the specimen will sink (settle) in the solution. The temperatures at which the specimen and standard reach the mid-point of the test tube are noted and by use of special tables, the density of the specimen is obtained.

3.2 *Range of a Given Density Solution*—A given density solution can be used to measure specimens whose density is within ± 0.0200 g/cm³ of the density of the solution at 35°C, by operating the comparator bath in the range 25 to 45°C.

4. Significance and Use

4.1 The sink-float comparator method of test for glass density provides the most accurate (yet convenient for practical applications) method of evaluating the density of small pieces or specimens of glass. The data obtained are useful for daily quality control of production, acceptance or rejection under specifications, and for special purposes in research and development.

4.2 Although this test scope is limited to a density range from 1.1 to 3.3 g/cm³, it may be extended (in principle) to higher densities by the use of other miscible liquids (Test Method F 77) such as water and thallium malonate-formate (approximately 5.0 g/cm³). The stability of the liquid and the precision of the test may be reduced somewhat, however, at higher densities.

5. Apparatus

5.1 *Single Tube and Multiple-Tube Comparators* (Method E 77)—A single-tube comparator can be constructed from materials readily available in a typical laboratory, and useful if one wishes to measure the density of materials within a fairly narrow range, or if only a few tests need to be run each day. The multiple-tube comparator can be purchased commercially.⁷ It is useful if materials with a wide range of density must be tested or if many specimens must be tested each day. The comparators shall consist of the following:

⁷ A multiple-tube comparator is available from American Glass Research, Inc., Box 149, Butler, PA 16001.

¹ This test method is under the jurisdiction of ASTM Committee C-14 on Glass and Glass Products and is the direct responsibility of Subcommittee C14.04 on Physical and Mechanical Properties.

Current edition approved Aug. 29, 1975. Published November 1975. Originally published as C 729 – 72 T. Last previous edition C 729 – 72 T.

² *Annual Book of ASTM Standards*, Vol 15.02.

³ *Annual Book of ASTM Standards*, Vol 05.01.

⁴ *Annual Book of ASTM Standards*, Vol 15.05.

⁵ *Annual Book of ASTM Standards*, Vol 14.02.

⁶ *Annual Book of ASTM Standards*, Vol 14.03.

5.1.1 Single-Tube Comparator (Fig. 1):

5.1.1.1 *Circulating Water Bath*, consisting of a 4000-cm³ beaker, a cover plate supporting test tubes and thermometer, a cooling water coil made from copper tubing, an electrically driven stirrer, and containing an immersion heater with rheostat for controlling heating rate, or heated by an external heat source such as a hot plate.

5.1.1.2 *Test Tubes*, two, 100-cm³ capacity. The cover plate supports the test tubes, which extended into the water bath. One tube contains the density solution, the test specimen, the standard, and a glass or TFE-fluorocarbon cage (Fig. 2) that keeps the specimens immersed in the solution. The second test

tube contains density solution and a thermometer; both test tubes employ rubber stoppers for supporting the cage or thermometer.

5.1.1.3 *Thermometers*, two, mercury, readable to 0.1°C between 20 and 50°C. One thermometer passes through a rubber stopper supported by the cover plate into the water bath. The second thermometer passes through a rubber stopper into the test tube that contains density solution only. Thermistor thermometers can be used instead of mercury thermometers, if desired.

5.1.2 *Multiple-Tube Comparator*—The commercially obtainable multiple-tube comparator employs the same principle

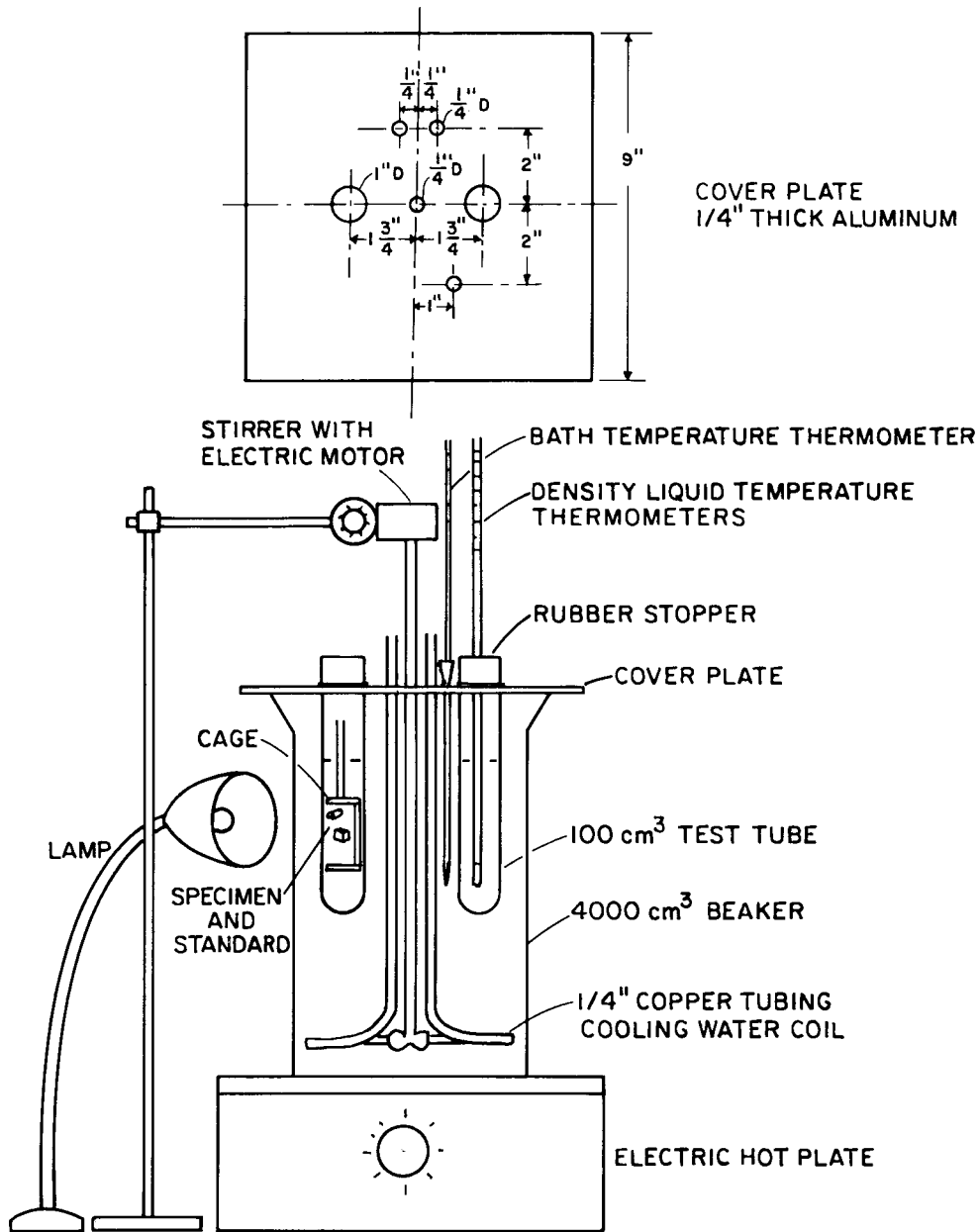

Metric Equivalents

in.	1/4	1/2	1	1 3/4	2	9
mm	6.4	12.7	25.4	44.4	51	229

FIG. 1 Single Tube Sink-Float Density Apparatus

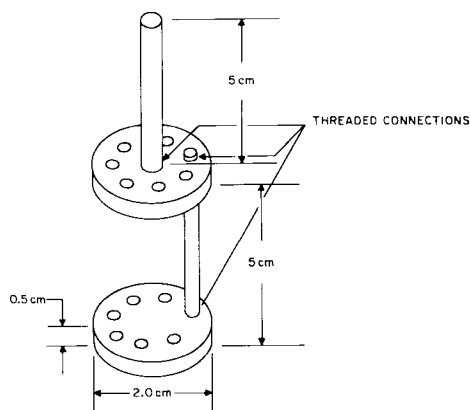

FIG. 2 TFE-Fluorocarbon Cage for 100-ml Test Tube

as the single-tube comparator, except that the multiple-tube type contains additional specimen tubes. These specimen tubes may contain similar density solutions if a large number of specimens with similar density are to be measured; they may contain density solutions of differing density if a number of specimens with a range of densities are to be measured.

6. Reagents and Materials

6.1 *Density Reference Standards*—The reference standard shall be a solid piece of glass with a volume between 0.10 and 0.15 cm³, and a ratio of major to minor dimensions not exceeding 2.0. It shall have a smooth surface and be free of seeds, cords, and cracks. A quantity of such standards may be cut from a 20-g piece of glass similarly free of defects, with density at 25°C (ρ_{25}) known to ± 0.0001 g/cm³. The density of such a standard glass can be determined to ± 0.00001 g/cm³ by a precise buoyancy method.⁸ Determine the settling temperature of each reference standard to the nearest 0.1°C and discard any that deviate more than 0.1°C from mean temperature. Less precise density standards are commercially available.⁹

6.2 *Density Solution*—The following organic liquids¹⁰ are mixed to provide a solution of the desired density:

6.2.1 *Isopropyl Salicylate*, density (25°C) approximately 1.10 g/cm³ or *alpha-bromonaphthalene*, density (25°C) approximately 1.49 g/cm³.

6.2.2 *sym-Tetrabromoethane*, density (25°C) approximately 2.96 g/cm³.

6.2.3 *Methylene Iodide*, density (25°C) approximately 3.32 g/cm³.

NOTE 1—Methylene iodide, *sym*-tetrabromoethane, and *alpha*-bromonaphthalene are light-sensitive. These liquids should be stored in light-protective containers. A piece of copper wire in the methylene iodide container will help retard decomposition.

6.2.4 The density solution consists of mixtures of isopropyl salicylate and *sym*-tetrabromoethane for densities between 1.10

and 2.96 g/cm³, and of *sym*-tetrabromoethane and methylene iodide for densities between 2.96 and 3.32 g/cm³. Proper amounts of the two liquids to be used are found by simultaneous solution of:

$$\rho_s V_s = \rho_1 V_1 + \rho_2 V_2 \quad (1)$$

$$V_s = V_1 + V_2 \quad (2)$$

$$\rho_s = (\rho_1 V_1 + \rho_2 V_2) / (V_1 + V_2) \quad (3)$$

where:

ρ_s = density of solution – density of standard at 35°C,

V_s = volume of solution to be prepared,

ρ_1 and ρ_2 = densities of the component liquids at 35°C, and

V_1 and V_2 = volumes of the component liquids at 35°C.

6.2.5 *Solution Preparation*—Approximate volumes of liquids required to supply desired density ρ_s are shown in Table 1. Mix the two required volumes of liquids 1 and 2 (6.2.4) in a beaker, set on a hot plate, and warm to 35°C. Place a density standard in the solution. Adjust the mixture by adding 1 or more drops of either component until the density standard settles at $35 \pm 0.2^\circ\text{C}$ in the well-stirred solution.

7. Preparation of Density-Temperature Tables

7.1 Tables are prepared from the equations of this section to relate the specimen density at 25°C to its settling temperature.

TABLE 1 Volumes of Liquids for Solutions of Various Densities

ρ_s g/cm ³ at 35°C	Volume of Material Used, cm ³		
	Isopropyl Salicylate	<i>sym</i> -Tetra-bromo-ethane	Methylene Iodide
2.103	135	165	...
2.136	127	173	...
2.190	120	180	...
2.222	115	185	...
2.236	113	187	...
2.257	109	191	...
2.291	104	196	...
2.315	100	200	...
2.335	95	205	...
2.363	92	208	...
2.403	85	215	...
2.434	80	220	...
2.448	78	222	...
2.473	74	226	...
2.495	70	230	...
2.511	68	232	...
2.529	65	235	...
2.560	60	240	...
2.589	56	244	...
2.596	54	246	...
2.619	50	250	...
2.633	48	252	...
2.669	42	258	...
2.702	37	263	...
2.728	33	267	...
2.757	28	272	...
2.812	19	281	...
2.847	13	287	...
2.863	10	290	...
2.893	6	294	...
2.933	...	300	1
2.960	...	277	23
2.999	...	248	52
3.035	...	214	86
3.054	...	198	102
3.096	...	168	132

⁸ Bowman, H. A., and Schoonover, R. M., "Procedure for High Precision Density Determinations by Hydrostatic Weighing," *Journal of Research*, National Bureau of Standards, 71 C, 3, 1967, p. 179.

⁹ Sources include:

American Glass Research, Inc., Box 149, Butler, PA 16001, Emhart Corporation, Hartford Division, P.O. Box 1620, Hartford, CT 06102, and Engineered Materials, P.O. Box 363, Church St. Station, New York, NY 10008.

¹⁰ These liquids are available from most chemical supply companies.

These tables are prepared once for each glass reference standard-density solution system. Subsequent supplies of density solutions prepared for use with the same glass reference standard will be sufficiently similar in expansion and density characteristics so that the same table can be used.

7.2 Determination of Temperature Coefficient of Density—Measure the density of the solution at approximately 25 and 45°C using the Bingham pycnometer, Test Method D 1217, or equivalent pycnometer method. Calculate the temperature coefficient of density, C_ρ , as follows:

$$C_\rho = (\rho_{T1} - \rho_{T2}) / (T_1 - T_2) \quad (4)$$

where:

C_ρ = temperature coefficient of the solution, $\text{g/cm}^3 \cdot ^\circ\text{C}$, and
 ρ_{T1} and ρ_{T2} = density of the solution at temperature T_1 and T_2 , g/cm^3 .

7.3 Equations for Determination of Density:

NOTE 2—Alternative equations or method of calculation may be used in conjunction with different density tables and standard settling temperatures.

7.3.1 These equations relate the specimen density to its settling temperatures. Express the exact relationship:

$$\rho_T = \rho_s + C_\rho(T - T_s) \quad (5)$$

where:

ρ_T = density of specimen at its settling temperature, T , and
 ρ_s = density of standard at its settling temperature, T_s , approximately 35°C.

7.3.2 If the thermal expansions of a specimen and standard are similar, express their densities at 25°C as follows:

$$\rho_{25} = \rho_{s25} + (C_\rho + 3\alpha_s\rho_s)(T - T_s) \quad (6)$$

where:

ρ_{25} = specimen density at 25°C,
 ρ_{s25} = standard density at 25°C, and
 α_s = linear expansion of standard \approx expansion of specimen.

7.3.3 It is convenient to fix 35°C as the settling temperature of the standard, as it will vary slightly with heating rate, operator, and liquid density. The specimen settling temperature must be corrected as follows:

$$T_c = T + (35 - T_s) \quad (7)$$

where:

T_c = corrected specimen settling temperature,
 T = observed specimen settling temperature, and
 T_s = observed standard settling temperature.

Eq 6 then becomes:

$$\rho_{25} = \rho_{s25} + (C_\rho + 3\alpha_s\rho_s)(T_c - 35) \quad (8)$$

7.4 Density Table—This table is prepared and used when many routine densities are to be determined. Eq 8 is solved for T_c between 25 and 45°C in 0.1°C increments, and specimen density at 25°C is tabulated with corrected specimen settling temperature T_c . A typical density table is shown in Table 2.

7.5 Density Equation for Unlike Expansions—If the thermal expansions of specimen and standard differ, specimen density will be in error by approximately 0.0001 g/cm^3 for every

$20 \times 10^{-7}/^\circ\text{C}$ mismatch in expansion. This error is greater if the specimen settles above 35°C and less if it settles below 35°C. Use the following equation, which is accurate to $\pm 0.0001 \text{ g/cm}^3$:

$$\rho_{25} = \rho_{s25}[(1.0000 - 30\alpha_s) + 3\alpha(T_c - 25)] + C_\rho(T_c - 35) \quad (9)$$

where: α = linear expansion coefficient of specimen.

8. Procedure for Determining Density of Test Specimens

8.1 Prepare the specimen for testing by cutting from the sample a piece comparable in size with the standard. The test specimen should be smooth and free of bubbles and cracks. Identify the specimen using a diamond-point marking pencil or by cutting it to a distinctive shape. Clean the specimen in reagent grade alcohol or acetone and wipe dry with silicone-free lens tissue. Place specimen in the solution (Note 3) that contains the standard. The bath and solution temperatures should be approximately $25 \pm 3^\circ\text{C}$, and both specimen and standard should float.

NOTE 3—Adsorbed moisture on the specimen surface will lower the measured density. Moisture, from condensation, on the solution surface should be removed by periodically filtering the solution through coarse filter paper.

8.2 Place all the tubes, thermometers, stoppers, etc., in their proper location in the bath, and rapidly heat the bath (1 to $2^\circ\text{C}/\text{min}$), noting the temperature of the density solution at which the test specimen (or the standard) begins to settle.

8.3 Adjust the bath temperature by cooling to 2 to 4°C below the expected settling temperature of the specimen (or standard). Allow the bath and solutions to come to equilibrium for 10 min, then heat the bath at a rate of $0.1 \pm 0.02^\circ\text{C}/\text{min}$. Heating rates can be controlled by adjusting the power to the hotplate or immersion heater and the cooling water flow rate. Cooling water is used as a fine adjustment of heating rate.

8.4 As either the specimen or standard begin to settle in the solutions, note the temperature at which either is halfway between upper and lower cage disks. The bath and density solution temperatures must agree within 0.4°C when the temperature is recorded, with the bath temperature being higher. Record T and T_s .

8.5 Calculate the corrected specimen settling temperature, T_c , by Eq 7. From an appropriate density table prepared from Eq 4 and Eq 8, read the density that corresponds to the corrected specimen settling temperature, T_c . This density is the density of the specimen at 25°C, ρ_{25} .

8.6 Up to three test specimens can be run in a single tube simultaneously.

9. Report

9.1 Report the following:

9.1.1 Identification of test sample, product, manufacturer, code number, date, etc. as required,

9.1.2 Test information, including test date, density solution and table used, identification and uncertainty of density standard, settling temperatures of standard and test specimen, and other required data, and

9.1.3 Density of test specimen or average density of test lot, at 25°C, as determined from density table.

TABLE 2 2.511 Density Liquid
 Glass Density at 25°C in g/cm³
 Standard Settling Temperature Adjusted to 35°C^{A,B}

T_c	ρ_{25}	T_c	ρ_{25}	T_c	ρ_{25}	T_c	ρ_{25}	T_c	ρ_{25}
25.0	2.5305	29.0	2.5228	33.0	2.5151	37.0	2.5074	41.0	2.4997
25.1	2.5303	29.1	2.5226	33.1	2.5149	37.1	2.5072	41.1	2.4995
25.2	2.5301	29.2	2.5224	33.2	2.5148	37.2	2.5071	41.2	2.4993
25.3	2.5299	29.3	2.5222	33.3	2.5146	37.3	2.5069	41.3	2.4991
25.4	2.5297	29.4	2.5221	33.4	2.5144	37.4	2.5067	41.4	2.4989
25.5	2.5295	29.5	2.5219	33.5	2.5142	37.5	2.5065	41.5	2.4988
25.6	2.5293	29.6	2.5217	33.6	2.5140	37.6	2.5063	41.6	2.4986
25.7	2.5292	29.7	2.5215	33.7	2.5138	37.7	2.5061	41.7	2.4984
25.8	2.5290	29.8	2.5213	33.8	2.5136	37.8	2.5059	41.8	2.4982
25.9	2.5288	29.9	2.5211	33.9	2.5134	37.9	2.5057	41.9	2.4980
26.0	2.5286	30.0	2.5209	34.0	2.5132	38.0	2.5055	42.0	2.4978
26.1	2.5284	30.1	2.5207	34.1	2.5130	38.1	2.5053	42.1	2.4976
26.2	2.5282	30.2	2.5205	34.2	2.5128	38.2	2.5051	42.2	2.4974
26.3	2.5280	30.3	2.5203	34.3	2.5126	38.3	2.5049	42.3	2.4972
26.4	2.5278	30.4	2.5201	34.4	2.5125	38.4	2.5047	42.4	2.4970
26.5	2.5276	30.5	2.5199	34.5	2.5123	38.5	2.5045	42.5	2.4968
26.6	2.5274	30.6	2.5197	34.6	2.5121	38.6	2.5044	42.6	2.4966
26.7	2.5272	30.7	2.5196	34.7	2.5119	38.7	2.5042	42.7	2.4964
26.8	2.5270	30.8	2.5194	34.8	2.5117	38.8	2.5040	42.8	2.4962
26.9	2.5269	30.9	2.5192	34.9	2.5115	38.9	2.5038	42.9	2.4961
27.0	2.5267	31.0	2.5190	35.0	2.5113	39.0	2.5036	43.0	2.4959
27.1	2.5265	31.1	2.5188	35.1	2.5111	39.1	2.5034	43.1	2.4957
27.2	2.5263	31.2	2.5186	35.2	2.5109	39.2	2.5032	43.2	2.4955
27.3	2.5261	31.3	2.5184	35.3	2.5107	39.3	2.5030	43.3	2.4953
27.4	2.5259	31.4	2.5182	35.4	2.5105	39.4	2.5028	43.4	2.4951
27.5	2.5257	31.5	2.5180	35.5	2.5103	39.5	2.5026	43.5	2.4949
27.6	2.5255	31.6	2.5178	35.6	2.5101	39.6	2.5024	43.6	2.4947
27.7	2.5253	31.7	2.5176	35.7	2.5099	39.7	2.5022	43.7	2.4945
27.8	2.5251	31.8	2.5174	35.8	2.5098	39.8	2.5020	43.8	2.4943
27.9	2.5249	31.9	2.5173	35.9	2.5096	39.9	2.5018	43.9	2.4941
28.0	2.5247	32.0	2.5171	36.0	2.5094	40.0	2.5017	44.0	2.4939
28.1	2.5245	32.1	2.5169	36.1	2.5092	40.1	2.5015	44.1	2.4937
28.2	2.5244	32.2	2.5167	36.2	2.5090	40.2	2.5013	44.2	2.4935
28.3	2.5242	32.3	2.5165	36.3	2.5088	40.3	2.5011	44.3	2.4934
28.4	2.5240	32.4	2.5163	36.4	2.5086	40.4	2.5009	44.4	2.4932
28.5	2.5238	32.5	2.5161	36.5	2.5084	40.5	2.5007	44.5	2.4930
28.6	2.5236	32.6	2.5159	36.6	2.5082	40.6	2.5005	44.6	2.4928
28.7	2.5234	32.7	2.5157	36.7	2.5080	40.7	2.5003	44.7	2.4926
28.8	2.5232	32.8	2.5155	36.8	2.5078	40.8	2.5001	44.8	2.4924
28.9	2.5230	32.9	2.5153	36.9	2.5076	40.9	2.4999	44.9	2.4922
								45.0	2.4920

^A Standard: soda-lime glass.
^B Table Coefficient: 0.001925 g/cm³ °C.

10. Precision and Bias

10.1 The standard deviation of this test method is approximately 0.0001 g/cm³. The precision with 95 % confidence limits is ±0.0002 g/cm³. By using a standard whose density is known to the 5th decimal place (±0.00001 g/cm³), the method

is accurate to ±0.0002 g/cm³.

11. Keywords

11.1 density; glass; sink-float

The American Society for Testing and Materials takes no position respecting the validity of any patent rights asserted in connection with any item mentioned in this standard. Users of this standard are expressly advised that determination of the validity of any such patent rights, and the risk of infringement of such rights, are entirely their own responsibility.

This standard is subject to revision at any time by the responsible technical committee and must be reviewed every five years and if not revised, either reapproved or withdrawn. Your comments are invited either for revision of this standard or for additional standards and should be addressed to ASTM Headquarters. Your comments will receive careful consideration at a meeting of the responsible technical committee, which you may attend. If you feel that your comments have not received a fair hearing you should make your views known to the ASTM Committee on Standards, 100 Barr Harbor Drive, West Conshohocken, PA 19428.