



# Standard Practice for Conducting Creep Tests of Metal-to-Metal Adhesives<sup>1</sup>

This standard is issued under the fixed designation D 1780; the number immediately following the designation indicates the year of original adoption or, in the case of revision, the year of last revision. A number in parentheses indicates the year of last reappraisal. A superscript epsilon ( $\epsilon$ ) indicates an editorial change since the last revision or reappraisal.

*This standard has been approved for use by agencies of the Department of Defense.*

## 1. Scope

1.1 This practice covers the determination of the amount of creep of metal-to-metal adhesive bonds due to the combined effects of temperature, tensile shear stress, and time.

NOTE 1—Since the characteristics that render a material resistant to creep under the condition of test are not yet completely known, the details of the procedure considered herein are those known to have important influences. Since other equally important characteristics may be discovered in the future, the recommended details are largely advisory in nature.

1.2 Test periods depend upon the reasonable life expected from the material in service. The uncertainties of extrapolation should be considered in deciding upon the length of the test.

1.3 The values stated in SI units are to be regarded as the standard. The values given in parentheses are provided for information purposes only.

1.4 *This standard does not purport to address all of the safety concerns, if any, associated with its use. It is the responsibility of the user of this standard to establish appropriate safety and health practices and determine the applicability of regulatory limitations prior to use.*

## 2. Referenced Documents

### 2.1 ASTM Standards:

D 907 Terminology of Adhesives<sup>2</sup>

D 1002 Test Method for Apparent Shear Strength of Single-Lap-Joint Adhesively Bonded Metal Specimens by Tension Loading (Metal-to-Metal)<sup>2</sup>

## 3. Terminology

3.1 *Definitions*—Many of the terms in this practice are defined in Terminology D 907.

### 3.2 Descriptions of Terms Specific to This Standard:

3.2.1 *creep*—the time-dependent part of the strain that results from exposure to a constant temperature and load (Note 2). That is, the creep at a given elapsed time is equal to the total strain at the given time minus the instantaneous strain (Note 3)

on loading. The creep extension is expressed as a percentage, that is, the extension divided by the initial unstretched length multiplied by 100.

NOTE 2—Constant-stress creep tests are desirable. The usual one is a constant deadweight load test. Creep tests made by means of spring loading or fixtures which involve deflection or strain measurements in the fixture for the application of load are unsatisfactory. However, if the total deformation or extension in the adhesive is large, corrections must be made to compensate for the decrease in stress because of the extension in the adhesive.

NOTE 3—Since the time-dependent strain develops rapidly even during the application of the load, the instantaneous strain for recovery is usually difficult to determine, except in the arbitrary manner given in the definitions of instantaneous strain and instantaneous recovery.

3.2.2 *deformation*—the total strain at any specific time.

3.2.3 *failure*—rupture of the specimen, or exceeding the strain requirements of a specific design.

3.2.4 *instantaneous recovery*—the decrease in strain occurring immediately upon unloading a specimen. As in instantaneous strain, a more reproducible value is obtained if the decrease in strain is measured after a given small increment of time (such as 1 min) following unloading. The increment of time used shall be specified. The instantaneous recovery shall be expressed in the same units as strain, that is, the decrease in length divided by the gage length usually, in inches per inch.

3.2.5 *instantaneous strain*—the strain occurring immediately upon loading a creep specimen. Since it is nearly impossible to obtain strain readings at the instant of loading, the strain after a given small increment of time (such as 1 min) after loading is a more reproducible value. The increment of time used shall be specified. The instantaneous strain shall be expressed in the units as strain, that is, the extension divided by the gage length, usually in inches per inch.

3.2.6 *recovery*—the time-dependent portion of the decrease in strain following unloading of a specimen at the same constant temperature as the initial test. Recovery is equal to the total decrease in strain minus the instantaneous recovery (see Note 3). The recovery shall be expressed in the same units as instantaneous recovery.

## 4. Significance and Use

4.1 This practice provides information on the creep of

<sup>1</sup> This practice is under the jurisdiction of ASTM Committee D-14 on Adhesives and is the direct responsibility of Subcommittee D14.80 on Metal Bonding Adhesives.

Current edition approved April 10, 1999. Published July 1999. Originally published as D1780 – 60 T. Last previous edition D1780 – 94.

<sup>2</sup> *Annual Book of ASTM Standards*, Vol 15.06.

bonded metal parts subjected to combined effects of temperature, shear, and time.

**5. Possibilities and Limitations**

5.1 The primary use of creep tests is to provide basic data for the choice of safe working stresses for applications in which allowable deformation within the service life of the structure is the criterion of failure.

5.2 Creep is an extremely sensitive index of strength, and usually does not vary as a linear function of stress. (It depends on the material, stress, temperature, and time.)

5.3 In the application of the following test requirements and recommendations it is assumed that the test specimens of a given adhesive bond are essentially comparable and truly representative of the material. In tests conducted to show the effects of temperature or stress as variables, great care must be used to ensure that the specimens are representative of the adhesive bond. Departure from this assumption may introduce discrepancies as great as, if not greater than, those due to departure from details of procedure outlined in this practice.

**6. Apparatus**

6.1 *Testing Machine*, capable of producing a tensile load on the specimen at the rate indicated in 10.2 and consisting of the following:

6.1.1 *Fixed Member*—A fixed or essentially stationary member, carrying one grip.

6.1.2 *Movable Member*—A movable member, carrying a second grip.

6.1.3 *Grips*—The grips, designed to minimize eccentric loading of the specimen. A swivel or universal joint near each end of the specimen is desirable wherever possible.

6.2 *Microscope*—A calibrated microscope having a Filar micrometer eyepiece and a 10× objective lens.

**7. Temperature Control and Measurement**

7.1 For tests at a particular temperature, maintain the specimen at a constant temperature, preferably by a suitable automatic control device. Where a furnace or cold box is used, it is desirable to locate this unit in a constant-temperature room to aid in temperature control.

7.2 The determination of the temperature of the specimen during the test is the most important single measurement in connection with creep testing, because small variations in temperature may produce large changes in creep rate. Maintain a uniform temperature over the test section with a maximum variation not to exceed ±1°C (1.8°F). Hold the maximum deviation of the temperature throughout the duration of the test period to ±1°C. State any fluctuation beyond this tolerance in reporting the test. Make the range of the normal control cycle a matter of record for the apparatus.

7.3 Take care to obtain reliable and accurate master temperature standards and check these at suitable intervals. When thermocouples are used in the test, use one of known calibration, checked before testing and after long-time exposures.

7.4 Use two thermocouples for measuring temperatures of the specimens throughout the test. Place these on opposite edges of the specimen at the end of the lap joint in the glue line. In furnaces not having equalized temperature over a 51-mm (2-in.) zone place additional thermocouples at each end of the 51-mm center section of the specimen to ensure equal temperature distribution.

7.5 Keep a continual record of the thermocouple measurements throughout the test. An automatic recorder of the strip-chart type is preferred. If automatic equipment is not available, make visual observations at sufficiently close intervals of time to ensure accuracy of temperature control throughout the test.

**8. Vibration Control**

8.1 Since creep tests especially are quite sensitive to shock and vibration, select the location of the testing apparatus for a minimum of disturbance. When the possible locations are not free of vibrations, design the test equipment and mounting so that the specimen is isolated from shock and vibration.

**9. Test Specimens**

9.1 Prepare test panels, 190.5 by 305 mm (7½ by 12 in.) from 1.6-mm (0.063-in.) metal, as shown in Fig. 1. Machine all edges of the panels within the completed bonded lap-joint true and smooth before the panels are cleaned and bonded.

9.2 Clean and bond the panels in accordance with the

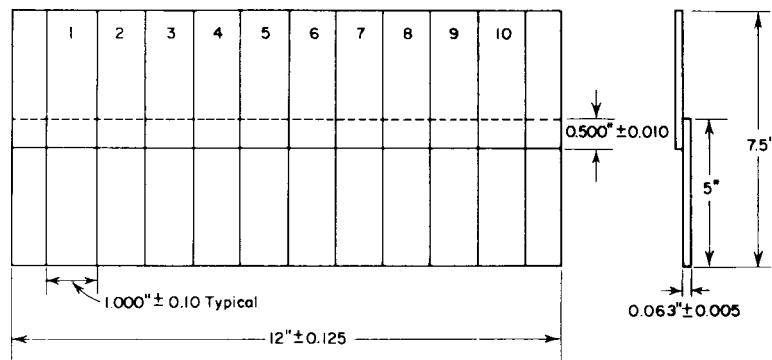

Metric Equivalents

in.	0.005	0.010	0.063	0.10	0.125	0.500	1.000	5	7.5	12
mm	0.127	0.254	1.600	2.54	3.175	12.7	25.4	127	190.5	305

**FIG. 1 Test Panel Construction and Orientation of Test Specimens in Panel**

adhesive manufacturer's instructions. The bonded lap for all test panels is  $12.70 \pm 0.25$  mm ( $0.500 \pm 0.010$  in.). Cut panels into 25-mm (1-in.) wide specimens for testing. Ensure all edges to be smooth and free of burrs, tool marks, and scratches. Fig. 2 shows the location of the scribe lines used to determine the deformation.

**10. Number of Test Specimens**

10.1 Test a minimum of three specimens from each panel for each plotted point on the curve.

10.2 Test a minimum of two specimens from each panel to destruction in tensile shear in accordance with Test Method D 1002 at the corresponding creep test temperature. The loading rate is 8.3 to 9.7-MPa (1200 to 1400-psi) shear stress per minute in the adhesive.

**11. Procedure**

11.1 Make three fine scribe lines across the machined vertical edges of the specimen at each edge of the joint exposed by machining of the specimens from the bonded panel. Place one scribe line across the center of the lap joint and the other two at a distance of  $0.76 \pm 0.25$  mm ( $0.030 \pm 0.010$  in.) from the ends of the lap joint (see Fig. 2).

11.2 Record the readings of the Filar micrometer prior to the application of the test temperature (if different from room temperature), immediately after the test temperature is reached, at intervals during any preshrinkage treatment, and immediately after the test load is applied. The total number and intervals of subsequent readings depend on the adhesive.

11.3 Apply the prescribed load, measured to within 1 %, as soon as the temperature equilibrium in the specimen is obtained or within a time period not to exceed 60 min. Apply the

test load quickly, but gently. Direct deadweight loading or the use of a simple lever is preferred, provided the laboratory is free of shock and vibration.

11.4 Take great care to avoid eccentricity. Check the entire assembly of specimen and loading mechanism for alignment in a suitable fixture properly instrumented prior to the test. Long pull rods facilitate obtaining proper alignment. Make changes in the assembly until alignment is obtained.

11.5 Measure the deformation directly by observing the displacement of the three scribe lines with the calibrated microscope. Measure the deformation to an accuracy of 0.025 mm (0.001 in.) at such intervals of time that a smooth time—deformation curve may be plotted. The exact time intervals will depend upon the adhesive being tested and the creep rate of the joint.

11.6 Throughout the duration of the test, keep records of the deformation so as to maintain a complete record of the deformation and the time. Determine the deformation of each specimen by averaging the deformation measurements at the prescribed points on the joint. Measure the glue line thickness to the nearest 0.0025 mm (0.0001 in.).

11.7 Exercise care in loading the specimen to keep the amount of vibration and shock at a minimum in order to ensure the accuracy of the initial measurements. Take the same precaution throughout the test period.

11.8 After unloading the specimen at the end of the extension measurements, make a record of the recovery versus the time occurring in the test specimen. Exercise caution when loading and unloading the specimen to obtain satisfactory overall accuracy of the tests.

**12. Fundamental Measurements**

12.1 Measurements to be recorded include: instantaneous strain, deformation, length of time, load, instantaneous recovery, adhesive bond area, glue line thickness, and temperature. Of these eight quantities, length of time, bond area, and glue line thickness present little difficulty, while frictional effects are the only particular considerations in connection with the applied load. Measurement of deformation and temperature are more difficult.

**13. Plotting Results**

13.1 The deformation—time curves may be plotted on ordinary rectangular coordinates. Express time in hours and use as the scale for the abscissa.

13.2 It is often more useful to plot creep as a function of time on log-log coordinates. Such plots often result in nearly straight-line diagrams, which facilitate interpolation and extrapolation, as well as interpretation.

**14. Report**

14.1 Report the following information:

14.1.1 Complete identification of the adhesive tested, including type, source, manufacturer's code number, etc.,

14.1.2 Identification of materials used as adherends and method of surface preparation used,

14.1.3 Method of application of adhesive and curing conditions used,

14.1.4 Average thickness of adhesive layer after formation

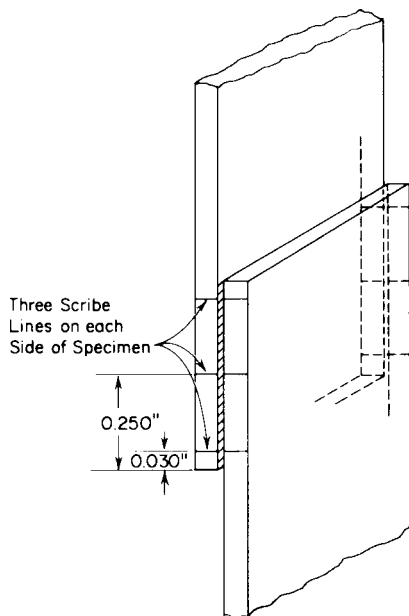

Metric Equivalents

in.	0.030	0.762
mm	0.250	6.350

**FIG. 2 Creep Rupture Test Specimen Showing Location of Scribe Lines for Deformation Measurement**

of the joint, within 0.025 mm (0.001 in.). Method of obtaining the thickness of the adhesive layer, including procedure, location of measurements, and range of measurements.

- 14.1.5 Conditioning procedure used, if any,
- 14.1.6 Testing temperature, °C (°F),
- 14.1.7 Adhesive shear stress applied, kgN/mm<sup>2</sup> (psi),
- 14.1.8 Total test time, h
- 14.1.9 Initial deformation, mm (in.),
- 14.1.10 Total deformation, mm (in.), at specific time intervals,

- 14.1.11 Total creep, mm (in.), for the period of the test,
- 14.1.12 Creep rate, mm/h (in./h),
- 14.1.13 Specimen number, and
- 14.1.14 Failure, if any.

## **15. Keywords**

- 15.1 creep; failure; load; recovery; strain; stress

*The American Society for Testing and Materials takes no position respecting the validity of any patent rights asserted in connection with any item mentioned in this standard. Users of this standard are expressly advised that determination of the validity of any such patent rights, and the risk of infringement of such rights, are entirely their own responsibility.*

*This standard is subject to revision at any time by the responsible technical committee and must be reviewed every five years and if not revised, either reapproved or withdrawn. Your comments are invited either for revision of this standard or for additional standards and should be addressed to ASTM Headquarters. Your comments will receive careful consideration at a meeting of the responsible technical committee, which you may attend. If you feel that your comments have not received a fair hearing you should make your views known to the ASTM Committee on Standards, 100 Barr Harbor Drive, West Conshohocken, PA 19428.*