



Standard Test Methods for Multi-Modal Strength Testing of Autohesives (Contact Adhesives)¹

This standard is issued under the fixed designation D 1995; the number immediately following the designation indicates the year of original adoption or, in the case of revision, the year of last revision. A number in parentheses indicates the year of last reapproval. A superscript epsilon (ϵ) indicates an editorial change since the last revision or reapproval.

1. Scope

1.1 These test methods cover procedures by which autohesives can be tested in four commonly practiced stressing modes, namely: compression shear, cleavage, climbing drum peel, and T-peel, and in various combinations of rigid-to-rigid, flexible-to-rigid, and flexible-to-flexible adherends that include wood, aluminum, steel flakeboard, and plastic laminates. Quantitative test methods that involve bond formation by impact are also provided. Three pressure modes are provided: static, roller, and impact. Because there are many types of contact adhesives being used to bond many different materials under widely differing conditions, these test methods are designed to allow the user to select the test mode, coating thickness, temperature and relative humidity conditions, pressure magnitude and mode, open time, and bond-conditioning time.

1.1.1 The bond-formation process used with autohesives is unlike that of all other adhesives and in consequence, testing of autohesives requires methods that are unlike those provided by other ASTM standards. See Annex A1.

1.2 A choice of adherends is available in each test mode. The combination of adherends that can be bonded together is limited to those shown in Appendix X1.

1.3 Methods for application of pressure are available in each test mode. For a particular combination of substrates, the means available for application of pressure are limited to those shown in Appendix X2.

1.4 The values stated in inch-pound units are to be regarded as the standard. The SI units given in parentheses are for information only.

1.5 *This standard does not purport to address all of the safety concerns, if any, associated with its use. It is the responsibility of the user of this standard to establish appropriate safety and health practices and determine the applicability of regulatory limitations prior to use.* Specific precautionary statements are given in 7.5.

¹ These test methods are under the jurisdiction of Committee D14 on Adhesives and are the direct responsibility of Subcommittee D14.70 on Construction Adhesives.

Current edition approved April 1, 2004. Published April 2004. Originally approved in 1991. Last previous edition approved in 1992 as D 1995 – 92 (1998) ^{ϵ 1}.

2. Referenced Documents

2.1 ASTM Standards:²

- D 905 Test Method for Strength Properties of Adhesive Bonds in Shear by Compression Loading
- D 907 Terminology of Adhesives
- D 1062 Test Method for Cleavage Strength of Metal-to-Metal Adhesive Bonds
- D 1151 Practice for Effect of Moisture and Temperature on Adhesive Bonds
- D 1781 Test Method for Climbing Drum Peel Test for Adhesives
- D 1876 Test Method for Peel Resistance of Adhesives (T-Peel Test)
- D 2651 Guide for Preparation of Metal Surfaces for Adhesive Bonding
- E 4 Practices for Force Verification of Testing Machines

3. Terminology

3.1 *Definitions*—Many terms in these test methods are defined in Terminology D 907.

3.1.1 *autohesion, n*—adhesion developed by interdiffusion of the molecules of two solid surfaces of the same material and consequent obliteration of the interface between them.

3.1.2 *autohesive, n*—an adhesive possessing the property of autohesion. (Also called contact-bond adhesive and dry-bond adhesive.)

3.1.3 *shear strength, n*—in adhesive joint, the maximum average stress when a force is applied parallel to the joint.

3.1.3.1 *Discussion*—In most adhesive test methods, the shear strength is actually the maximum average stress at failure of the specimen, not necessarily the true maximum stress in the material.

3.2 Definitions of Terms Specific to This Standard:

3.2.1 *autohesive (contact) failure, n*—a condition in which no contact appears to have occurred between the two layers of autohesive, as evidence by visual inspection of the specimen after destructive testing.

² For referenced ASTM standards, visit the ASTM website, www.astm.org, or contact ASTM Customer Service at service@astm.org. For *Annual Book of ASTM Standards* volume information, refer to the standard's Document Summary page on the ASTM website.

3.2.2 *bond-conditioning time, n*—the time elapsed between making the bonded assembly and testing it or specimens made from it.

4. Summary of Test Methods

4.1 The autohesive is conditioned to the temperature selected for the coating application, the substrates are surfaced flat, precut or cleaned, or both, as required, and then conditioned to the temperature and humidity preselected for the coating application. Under controlled temperature and humidity, a film of autohesive of predetermined wet-film thickness is coated on to the substrates, and allowed to dry for the duration of the open-assembly time. The coated materials are brought together with light finger pressure, and bonded assemblies are made by applying pressure. Pressure may be applied in one of three ways: static, impact, or roller. Assemblies are conditioned in a controlled environment for a specified time, the bond-conditioning time. Assemblies are cut into specimens where required. Assemblies requiring no cutting, or precut specimens, are tested destructively in either of the four modes described in Sections 8, 9, 10, and 11.

5. Significance and Use

5.1 The application procedures in these test methods yield films free of the irregularities, artifacts, and variations inherent in brushing, spraying, or trowelling. Accordingly, these test methods measure the strength of autohesive bonds between two autohesive films whose topography is characteristic of the autohesive itself rather than the artifacts of the application procedure. It is recommended that this information be considered in extrapolating results from these test methods.

5.2 The magnitude of the measured bond strengths also depends on other factors such as film thickness, the manner in which pressure is applied, the magnitude and duration of the application of pressure, and the temperature and humidity at various stages of the test. Accordingly, these parameters should be chosen in a manner consistent with the end use of the autohesive.

5.3 In case of a dispute arising from differences in reported results when using these test methods for acceptance testing of commercial shipments, the purchaser and the supplier should conduct comparative tests to diagnose the causes for lack of repeatability between their laboratories. Competent statistical assistance is recommended for the investigation of precision. As a minimum, the two parties should select a group of test specimens and visually examine their failure modes. The average results from the two laboratories should then be compared using Student's *t*-test for unpaired data and an acceptable probability level should be chosen by the two parties before testing is begun.

6. Apparatus

6.1 Testing Machines:

6.1.1 Test Methods D 905, D 1062, D 1781, D 1876, and Guide D 2651 independently specify the testing machine relevant to these test methods.

6.1.2 To perform all tests in these test methods, the testing machine must meet the following requirements:

6.1.2.1 Capability of performing tests in tension and compression; load range 4400 lb (2000 N).

6.1.2.2 Rate of movement of the cross-head must be constant and independent of any fluctuation of the load.

6.1.2.3 A range of cross-head speeds from 0.05 in./min (1.27 mm/min) to 2 in./min, (50 mm/min).

6.1.2.4 The machine must be provided with a load-rate controller capable of controlling the load rate from 600 to 700 lbf/min (2700 to 3200 N/min).

6.1.2.5 Autographic equipment to record the load-versus-head movement.

6.1.3 Verification of the testing equipment may be made in accordance with the recommendations of Practices E 4.

6.2 *Equipment for Environmental Temperature and Humidity Control*—Equipment must be capable of maintaining relative humidity within $\pm 2\%$ of the selected value, and temperature within $\pm 2^\circ\text{F}$ ($\pm 1^\circ\text{C}$) of the selected value.

6.3 *Applicators*—Fixed or variable-gap applicators, commonly called knife applicators, may be used. The knife design, shown in Fig. 1³ or similar applicators provided with side

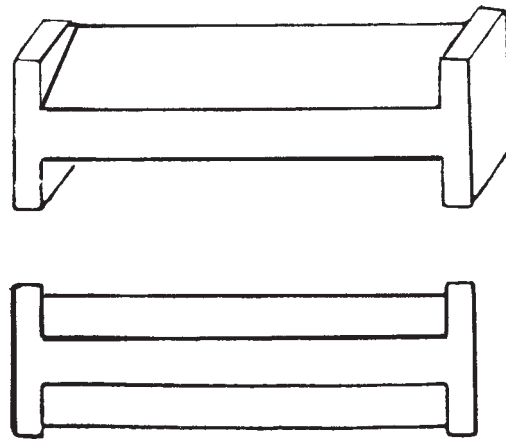

FIG. 1 One Type of Knife Applicator

guide arms at least 1 in. (25 mm) long, are preferred. Applicators shall be wide enough for the guide arms to ride on the rider pieces and at least 1 in. (25 mm), away from the edge of center substrate during application, as in Fig. 2. Wide-wound-rod applicators may also be used for deposition of wet films 0.002 to 0.010 in. (0.051 to 0.254 mm) thick. These applicators obviate the need for restraining devices to maintain flatness of sheet substrates while coating and are generally preferred over knife applicators provided the required wet-film thickness does not exceed 0.01 in. (0.254 mm). The wide-wound portion of the rod should be at least 2 in. (50 mm) longer than the adherend width. The wet-film thickness deposited by all wide-wound-rod applicators is not predictable from the diameter of the wire. Consult the manufacturer's data.⁴

³ Available from Precision Gage and Tool Co., Dayton, Ohio 45410.

⁴ Wire-wound applicators are available from the Leneta Co., PO Box 576 Ho-Ho-Kus, NJ 07423, from Byk Mallinckrodt Chemische Producte, 4230 Wessel Postfach 245, West Germany, and from Paul Gardner and Co. Inc., 218-D Commercial Blvd., Suite 205, Lauderdale-by-the-Sea, FL 33308-4491.

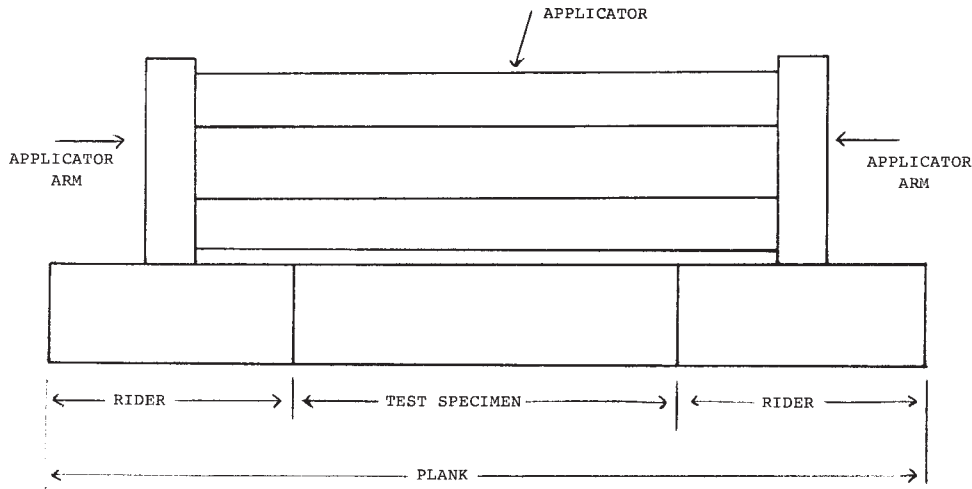

FIG. 2 Applicator Placed on Material for Coating

6.4 *Float-Glass Plate*, $\frac{1}{4}$ in. (6 mm) minimum thickness, minimum width and length 12 and 17 in. (0.3 and 0.4 m).

6.5 *Restraining Devices*, for coating sheet substrates while using knife applicators, restraining devices are required to maintain flatness.

6.5.1 *Machinists' Flat Magnetic Table*, recommended size 8 by 17 in. (0.2 by 0.4 m). (For steel only.)

6.5.2 *Vacuum Table*, minimum size 8 by 17 in. (0.2 by 0.4 m).

6.5.3 Whenever restraining devices in 6.5.1 and 6.5.2 are not available and knife applicators are to be used, sheet substrates can be rendered flat by taping their back sides to the plate-glass with 1 in. (25 mm) wide double-coated pressure-sensitive tape. The tape selected should allow removal of the sheets without creasing them.

6.6 *Pressure-Application Equipment*—Several methods for the application of pressure are provided. Selection is made by the user on the basis of field-use requirements.

6.6.1 *Static-Pressure-Application Equipment*—Hydraulic press: minimum capacity 5000 lb (23 000 N); minimum platen size 8 by 12 in. (0.2 by 0.3 m). Preferably, one of the platens should be mounted on a self-aligning joint. Both platens shall be ground flat and checked for parallelism and flatness with a machinist's straightedge.

6.6.2 *Rollers*—Steel rollers must be mounted on freely rotating axles; ball-bearing mounts are preferable. The roller design should conform generally with Fig. 3. Either of the two rollers specified may be used: a heavy roller 6 in. in diameter and 4 in. wide (155 mm in diameter by 100 mm wide) weighing 33 ± 1.0 lb (15 ± 0.5 kg); or a light roller 4-in. diameter and 2.5 in. wide (100-mm diameter by 64 mm wide) weighing 10 ± 0.5 lb (4.5 ± 0.25 kg).

6.6.3 *Impact-Application Equipment*—The Bellows impact press consisting of a series B772-006 arbour stand and a "Bellows Air Motor" Series B8013.⁵ The "Bellows" impact press is shown in Fig. 4 and Fig. 5.

⁵ This equipment can be purchased from Bellows-Valvair, Akron, Ohio 44309. Also from the same company offices in Glendale, CA 91201 and Toronto, Canada.

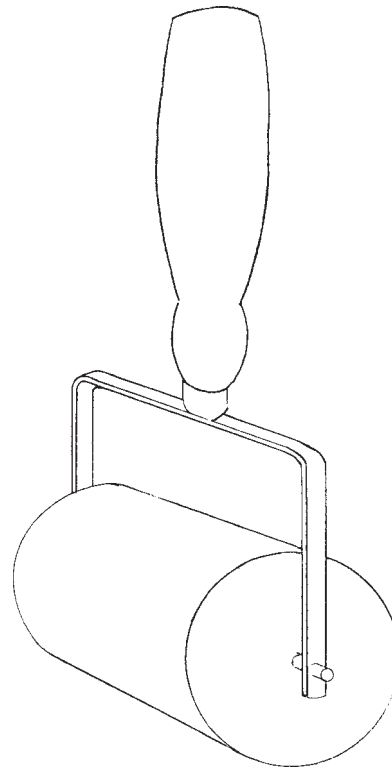

FIG. 3 Standard Steel Roller

6.7 *Surfacing Machines for Solid Wood*—The following two types of wood-working machines are required to make solid-wood specimens that are flat and of an even thickness.

6.7.1 A wood planer, sometimes referred to as a thickness planer. Any high-speed wood planer capable of producing a visibly smooth surface, free of any ripples or waves, and planks of equal thickness from end to end shall be acceptable.

6.7.2 A jointer-planer of sufficient width to accommodate 8-in. (20-cm) planks and that can be aligned to produce flat planks.

6.8 *Test Fixtures*—The fixtures described in the ASTM standards referenced in Section 2 were modified for the purposes of these test methods.

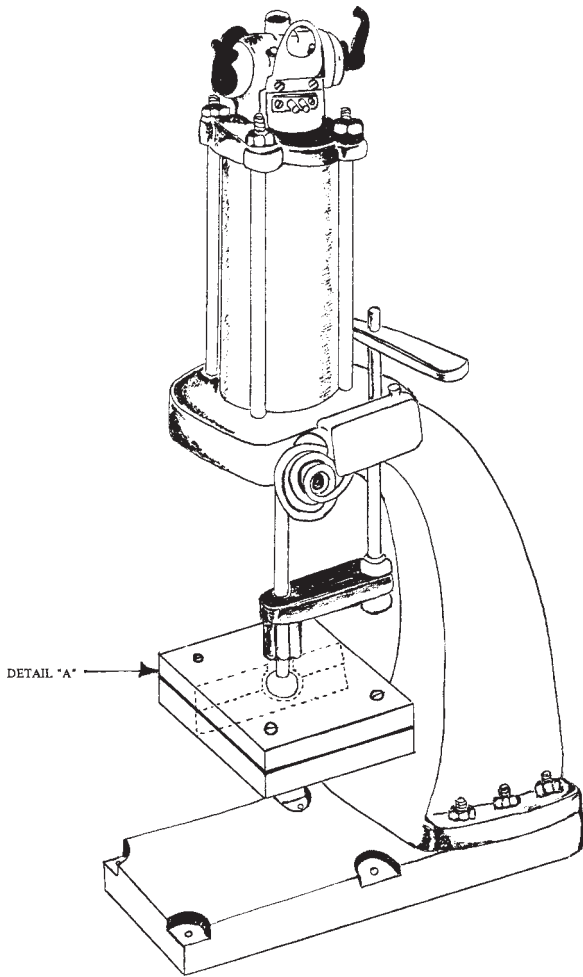

FIG. 4 The Bellows Air Valve Used for Impacting Peel Specimens

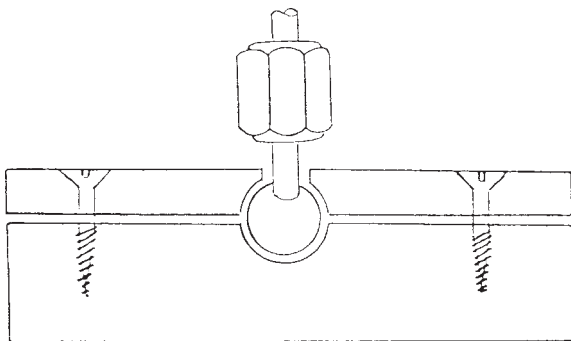
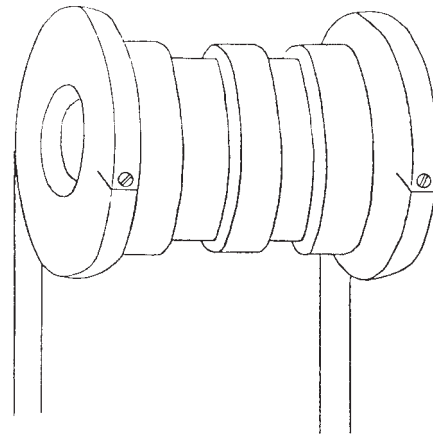

FIG. 5 Ball and Platen Assembly

6.8.1 The climbing drum prescribed in Test Method D 1781 has been modified according to Fig. 6, Fig. 7, Fig. 8, Fig. 9. The grooves in the drum customize it for use with the fixture in Fig. 8 by allowing the retaining lips on the fixturing device to fit into the grooves. This will unbalance the drum, but since controls are run and these are subtracted from the test results, the effect of the unbalance is nullified. The fixture in Fig. 8 is also a modification of the fixture in Fig. 4 of Test Method D 1781. It does not require pre-drilling the test specimens.

6.8.2 The fixture required for the cleavage test, Fig. 10, is a modification of the fixture in Fig. 1 of Test Method D 1062.



NOTE 1—Figures 6 and 7 show a drum that has been grooved to take in the fixturing lips of the fixture in Figs. 8 and 9.

FIG. 6 Climbing Peel Drum

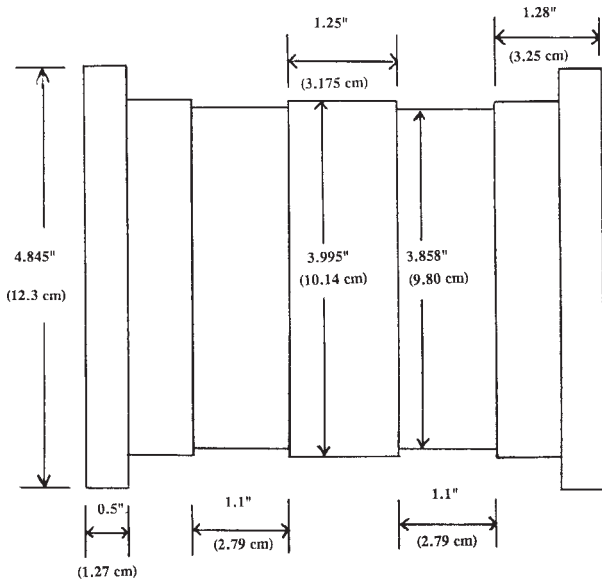

FIG. 7 Dimensions of Climbing Peel Drum

6.9 *Machinist's Straightedge*—A 12-in. (300-mm) machinist's straightedge (generally available from machinists' shops) is required. One of the lengthwise edges must be bevelled.

7. Test Materials

7.1 *Checking Flatness of Materials*—Lay the bevelled edge of a machinist's straightedge on the material perpendicular to its surface and along its width. While shining a bright light behind the straightedge, inspect the line of contact between the edge and the material. If the material is flat, no light should shine through. Make repeat observations at 2-in.(50-mm) intervals lengthwise. See Fig. 11.

7.1.1 *Material Dimensions*—See Table 1.

7.2 *Selection and Preparation of Maple Blocks*—Select hard maple blocks, kiln-dried, (*Acer saccharum* or *Acer nigrum*) having a minimum specific gravity of 0.65 based on oven-dry weight and volume, from planks that are of straight grain, that is, grain that runs parallel to the length of the plank, and free from defects including knots, birdseye, cross grain,

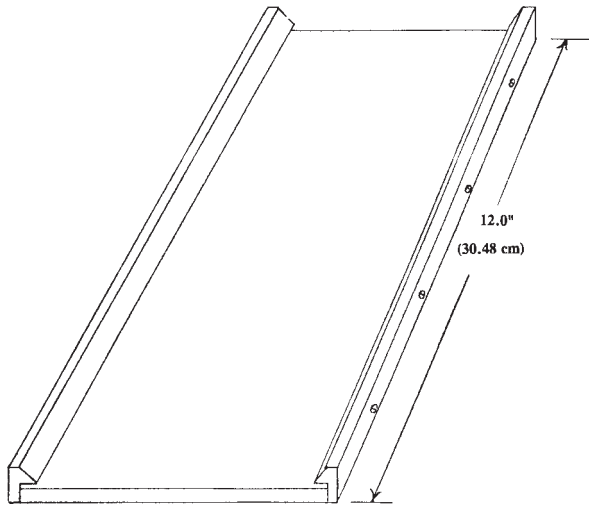

FIG. 8 End View of Specimen Holder for Climbing Drum Peel, Minus Specimen

decay, and any unusual discoloration. (See also Test Method D 905.) Select pre-surfaced wood that is reasonably flat. To facilitate meeting the flatness requirements, condition the wood to be cut or surfaced to equilibrium moisture content at the same relative humidity and temperature selected for the coating operation. The cutting operations need not be performed under these temperature and humidity conditions, but it is strongly advised that the wood to be cut should be returned as quickly as possible to the temperature and humidity environment selected for conditioning and coating. In this manner, changes in the moisture content of the wood that induce warping will be prevented. After moisture conditioning joint the surface to be bonded with a jointer-planer. Check the jointed surface for flatness with a machinist's straightedge. Then plane the opposite surface to the desired thickness with a thickness planer. Warping during storage can be minimized by stacking the wood with $\frac{3}{4}$ -in. (20-mm) spacers between planks. Restrain the ends by tying together cross pieces at the top and bottom of the bundle.

7.3 Douglas Fir—Solid wood Douglas fir blocks must have a minimum specific gravity of 0.4 based on oven-dry weight and volume. The grain must run parallel to the length of the plank, and be free from defects including knots, rosin exudations and discolorations within the test area. The same handling, storage, and flatness requirements apply as for hard maple, see 7.2. See Table 1 for dimensions. (Take note that Douglas fir is not used in the cleavage test.)

7.4 Particleboard or flakeboard must have a minimum density of 45 lb/ft³ (0.73 g/cm³). As delivered, it should be flat. After cutting to size, verify the flatness of the board as in 7.1. Reject any non-flat pieces.

7.4.1 See 7.1.1 for dimensions, take note that flakeboard is not used in the cleavage test.

7.5 Cold-Rolled Steel Sheets—Inspect cut sheets for burrs and bends and file along the edges if necessary to remove any protrusions. Discard bent or creased sheets. Before use, vapor degrease in accordance with Guide D 2651. Following degreasing, prepare specimens in accordance with Method D of

Guide D 2651. After degreasing, take care not to touch the surface to be bonded to avoid contamination and possible bond impairment.

NOTE 1—Warning: After degreasing, apply the autohesive within 1 h. Oxidation can occur in a very short time. Keep sheets that are not to be used within the hour immersed in water-free, pure, unused degreasing solvent, until ready for use.

7.6 Sheet Aluminum:

7.6.1 Any aluminum sheet alloy may be used. Typical sheet alloys are 2024-T3, 6061-T6, and 7075-T6.

7.6.2 Inspect cut sheets for burrs and bends and file along the edges if necessary to remove any protrusions. Discard bent or creased sheets. Follow by degreasing the sheets in accordance with 5.1 of Guide D 2651. After degreasing, take care not to touch the surface to be bonded to avoid contamination and possible bond impairment.

7.7 High-Pressure Laminate—Sheets must be constructed of phenolic backing and melamine facings, formed at 1000 to 2000 psi (6.9 to 13.8 MPa). To be used as rigid adherends in the compression shear, climbing drum peel, and cleavage methods, the decorative face of the high-pressure laminate must first be bonded to another flat, rigid material such as hard maple, Douglas fir, or flakeboard. Prepare the decorative face for bonding by roughening with 120-grit abrasive paper. Take care not to touch the prepared surface to avoid contamination and possible bond impairment. For bonding, use any adhesive which is known to be stronger than the autohesive being tested. Epoxy, resorcinol-formaldehyde, and urea-formaldehyde adhesives have been found suitable. Furthermore, the adhesive should flow uniformly throughout the surface to prevent any uneven topography. Avoid using paste adhesives. To maintain the flatness of the plastic laminate/flakeboard assembly, carry out the curing operation on a press in accordance with 6.6.1, taking care that all surfaces that come in contact with the laminate backing are clean and free of oil and grease.

8. Strength Testing in Shear by Compression Loading (See Test Method D 905)

8.1 The selections of adherends and pressure modes available in these test methods are shown in Table 1 and in Appendix X1 and Appendix X2. The strength of some of these materials may be inadequate for some autohesives under some test parameters. The materials listed rank as follows in decreasing order of strength: maple, Douglas-fir, flakeboard. Plastic laminates can be used in this test only by first laminating the decorative face of the laminate to one of the rigid materials as in 7.7.

8.2 Select the relative humidity and temperature for conditioning the materials. (See also 7.2.) These conditions may also be set by agreement between the user and the party requiring these tests. In the $23 \pm 1^\circ\text{C}$ absence of any specific requirements, use the standard conditions ($73 \pm 2^\circ\text{F}$) and $50 \pm 2\%$ relative humidity given in Practice D 1151. Maintain this environment while performing the operations described in 8.5, 8.6 (temperature only) 8.7, 8.8, 8.9, and 8.10.

8.3 Materials:

8.3.1 Precondition materials in the selected environment to equilibrium moisture content.

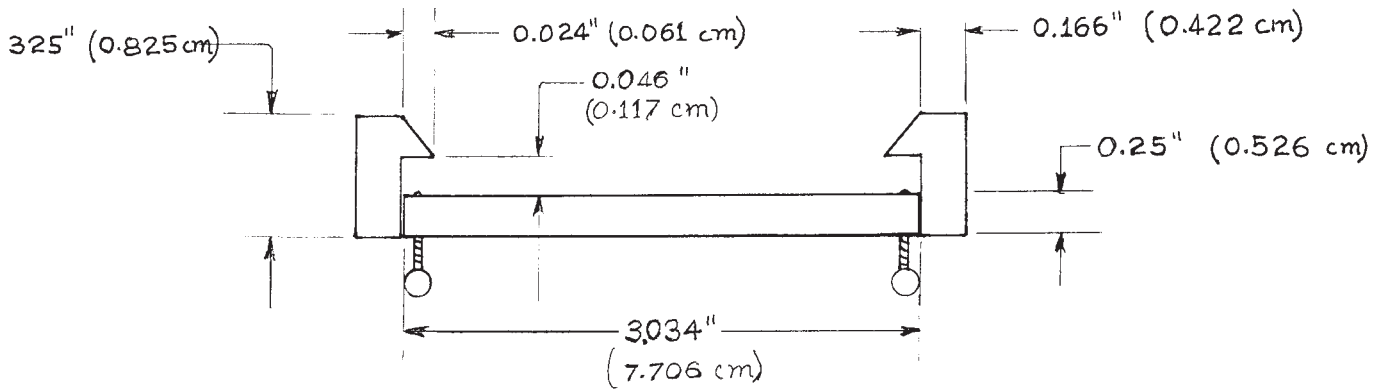

FIG. 9 Holding Fixture for 0.04 Steel Suitable for a Sample Width of 3.034 in. (7.706 cm)

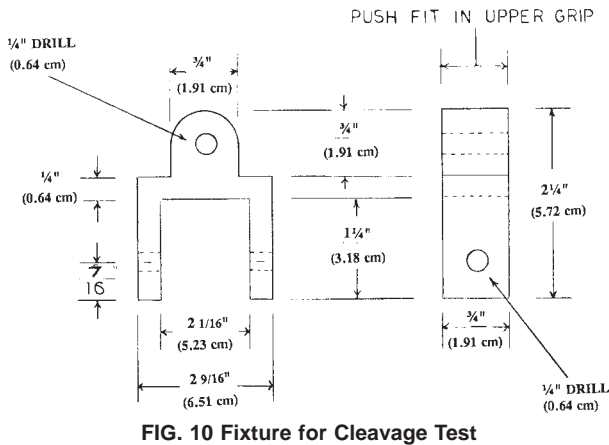

FIG. 10 Fixture for Cleavage Test

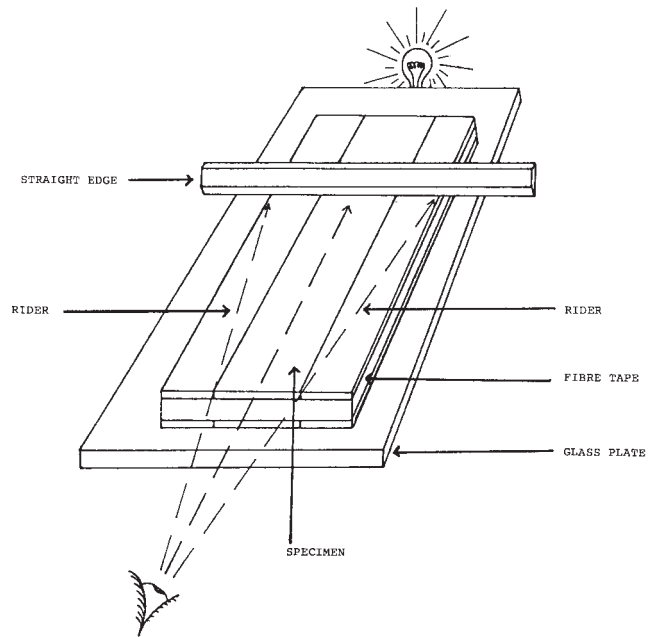

FIG. 11 Suspension for Flatness of Test Assembly Prior to Coating

8.3.2 For dimensions see Table 1.

8.4 Surfacing, Precutting, Reassembling, and Reconditioning of Materials:

8.4.1 For wood and flakeboard see 7.1 and 7.2. In the precutting operation cut planks into the adherends proper (the centre pieces) and two side pieces that, when placed next to the adherends, serve as supports or riders for the knife applicator and also prevent the formation of irregularities on the surface edges upon drying of the autohesive.

8.4.2 Before precutting, make the pieces so that they can be later taped together in the same order. To avoid warping, remove the materials to be cut from the conditioning environment just prior to cutting, and cut only the materials that can be used in the same day. Precut each of the two planks along the length into three sections of which the center section shall be 2 in. (5 mm) wide. See Fig. 2, Fig. 11, and Fig. 12. Immediately after cutting, return all sections to the environment selected in 8.2.

8.5 Condition the materials for 1 h. Reassemble the materials at this time by laying all the pieces on the plate glass with the side to be bonded facing the glass. Tape all three sections together, first on the back and then edgewise, as in Fig. 12, taking care that the lengthwise edges of the sections are in tight contact with one another and that they maintain perfect surface alignment during the taping operation. Check the flatness of the taped assembly, as in 7.1. Reject it if it is not flat.

8.6 Condition the autohesive to the temperature selected in 8.2.

8.7 Application of the Autohesive, Beginning of the Open-Assembly Time—In a location free of air drafts place the taped assembly on the plate glass and recheck for flatness, as in 7.1, rejecting any assemblies that are not flat. See Fig. 12. Select a knife applicator or wire-wound rod and record the gap or gage. Pour the autohesive at one end of the taped assembly over the whole width of the assembly, taking care that enough autohesive is applied. Repeat the coating operation with the second taped assembly, then start timing the preselected open-assembly time. Allow the coated materials to remain undisturbed for a minimum period of 5 min and preferably for as long as the selected open-assembly time allows before separating the sections. This permits the films to solidify so that on separation, the autohesive does not retract along the edges into a bead. The bead, if formed, will prevent uniform contact of the

TABLE 1 Substrate Materials and Dimensions Appropriate for Test Mode

| Test Mode | Substrate | Units | A | B | C | D |
|--|-----------|-------------------|----------------|----------------|--------------------|-------------------|
| | | | Shear | Cleavage | Climbing Drum Peel | T Peel |
| Wood, flakeboard, and high-pressure laminate assemblies ^A As above, center sections ^B | | inches, W × L × T | 5.5 × 12.5 × ¾ | 5.5 × 12.5 × 1 | 5.5 × 12.5 × ¾ | ... |
| | | mm | 140 × 320 × 18 | 140 × 320 × 25 | 140 × 320 × 18 | ... |
| | | inches, width | 2 | 2 | 3 | ... |
| Steel ^C | Rigid | mm | 50 | 50 | 75 | ... |
| | | inches, W × L × T | ... | ... | 3 × 12.5 × 0.036 | ... |
| Steel | Flexible | mm | ... | ... | 75 × 320 × 0.914 | ... |
| | | inches, W × L × T | ... | ... | 2.25 × 15 × 0.012 | 2.25 × 15 × 0.012 |
| Aluminum ^D | Flexible | mm | ... | ... | 60 × 380 × 0.305 | 60 × 380 × 0.304 |
| | | inches, W × L × T | ... | ... | 2.25 × 15 × 0.020 | 1 × 12 × 0.02 |
| | | mm | ... | ... | 60 × 380 × 0.5 | 25 × 320 × 0.5 |

^AWood/wood, wood/flakeboard, and high-pressure laminate assemblies of the dimensions shown, undergo further cutting. The center sections whose dimensions are shown, become the adherends upon bonding.

^BFlakeboard is not used in the cleavage test.

^CSteel plate of the width and length shown for the rigid member can also be used.

^DAluminum plate of the same width and length shown for rigid-steel sheets may be used as the rigid substrate. Otherwise, aluminum bonds in this test are limited to flexible aluminum sheets bonded to any of the other rigid substrates shown in this table.

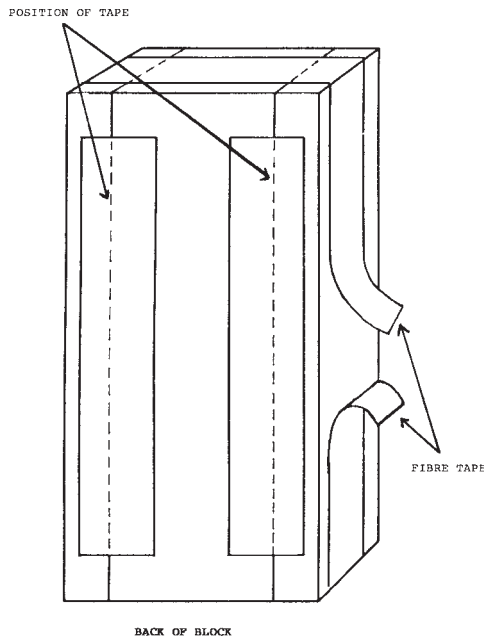

FIG. 12 Test Assembly Taped Prior to Coating

coated pieces and spoil the test. Without disturbing the surfaces, carefully remove the tape from the assembly and separate the coated pieces with a lateral pull.

8.8 *Conditioning the Coated Materials for the Duration of the Open-Assembly Time*—Place in an area protected from air drafts. Record the selected open-assembly time.

8.9 *Bonding the Coated Materials, Beginning of the Bond-Conditioning Time*—Upon expiration of the open-assembly time, align the coated sections to be bonded carefully with each other and establish contact of the coated sides by slight hand pressure just sufficient to make a handling bond. If contact occurs when the sections are misaligned, discard the materials.

8.10 *Application of Pressure*—Place the bonded assembly in a hydraulic press directly at the center of the platens and apply a preselected pressure for 5 s. Record the pressures in pound-force per square inch (megapascals) and the time. Pressures ranging from 50 to 200 psi (0.34 to 1.38 MPa) correlate with most field conditions. Record the time upon

removing the assembly from the press. This time marks the beginning of the bond-conditioning time. Select the duration of the bond-conditioning time and mark its expiration date and time on the assembly.

8.11 Store the bonded assembly at a selected temperature and relative humidity for the duration of the bond-conditioning time. Make a record of the environment.

8.12 Mark the assembly for cutting as in Fig. 13, numbering each of the specimens in sequence. No more than 4 h prior to the expiration of the bond-conditioning time, cut the assembly as in Fig. 13.

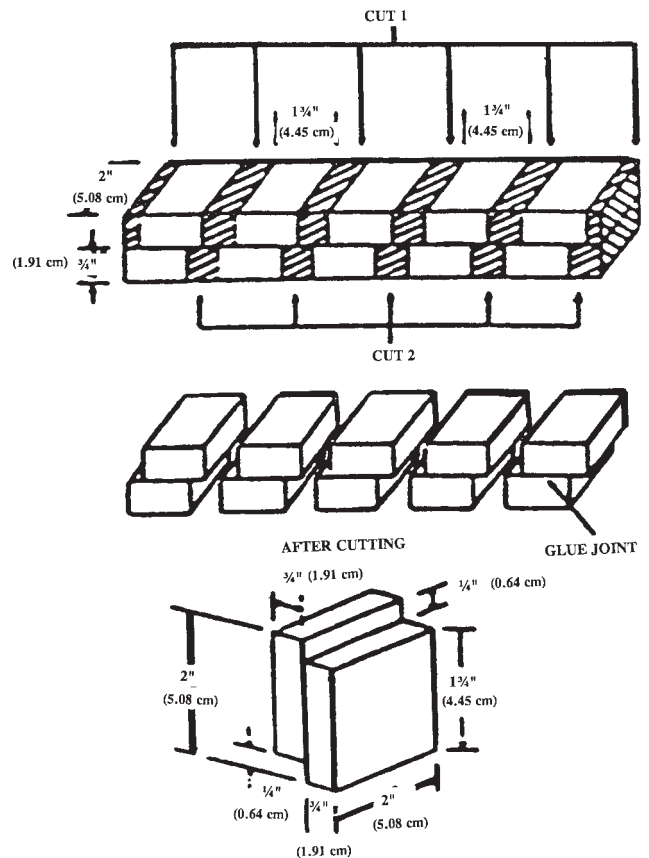

FIG. 13 Bonded Assembly Showing Cutting Schematics

8.13 *Procedure*—Prior to testing, measure the length and width of the bonded area of each specimen to the nearest 0.01 in. (0.25 mm). Upon the expiration of the bond-conditioning time place the specimen in the shearing tool so that the load may be applied as in Section 3 of Test Method D 905. Select the test environment. Tests may be performed in an environment equal to that in 8.2. Different environments can be selected according to parameters imposed by service conditions. Record the temperature and relative humidity during testing. Make a visual inspection of the failure mode and estimate the percentage of each failure type. Report failures as either substrate, adhesive, cohesive, or autohesive (contact). Failures are reported as autohesive when after the destructive test, previously contiguous areas of each autohesive film appear not to have fused and look undisturbed by the test. Record the breaking force in pounds (kilopascals).

8.14 *Calculation*—Calculate the shear stress at failure in pound-force per square inch (or megapascals) based on the bond area between the two laminations measured to the nearest 0.01 in.² (6 mm²) and record for each specimen.

8.15 *Report*—Include all items indicated in Test Method A in Fig. A1.1.

9. Strength Testing in Cleavage: Procedures for Making and Testing Specimens, Calculating, and Reporting of Results (See Test Method D 1062)

9.1 The selections of adherends and pressure modes available in this test mode are shown in Table 1 and in Appendix X1 and Appendix X2.

9.2 Select the relative humidity and temperature for conditioning the materials. (See also 7.2.)

9.2.1 These conditions may also be set by agreement between the user and the party requiring these tests. In the absence of specific requirements, use the standard conditions 23 ± 1°C (73 ± 2°F) and 50 ± 2 % relative humidity given in Practice D 1151.

9.2.2 Maintain this environment while performing the operations described in 8.5, 8.6 (temperature only), 8.7, 8.8, 8.9, and 8.10.

9.3 Materials:

9.3.1 Precondition materials in the selected environment to equilibrium moisture content.

9.3.2 For dimensions, see 7.1.1.

9.4 Surfacing, Precutting, Reassembling, and Reconditioning of Materials:

9.4.1 Follow procedures in 8.4-8.11 inclusive.

9.5 Mark the assembly for cutting as in Fig. 14, numbering each of the specimens in sequence. No more than 4 h prior to the expiration of the bond-conditioning time, cut the assembly as in Fig. 14.

9.6 *Procedure*—Measure the length and width of the bonded area of each specimen to the nearest 0.01 in. (0.25 mm). Upon the expiration of the bond-conditioning time place the specimen in the cleavage tool and apply a tensile load with the crosshead adjusted to 0.05 in. (1.27 mm)/min. Select the test environment. The test may be performed in an environment equal to that in 8.2. Different environments can be selected according to parameters imposed by service conditions. Record the temperature and relative humidity during testing. Make a visual inspection of the failure mode and estimate the percentage of each type of failure. Failures shall be reported as either substrate, adhesive, cohesive, or autohesive (contact). Failures are reported as autohesive when, after the destructive test, previously contiguous areas of each autohesive film appear not to have fused and look undisturbed by the test. Record the cleavage value in pounds per inch width (kilograms per centimetre width).

9.7 *Calculation*—Cleavage strength shall be the breaking load and shall be expressed in pounds per inch width (kilograms per centimetre width).

9.8 *Report*—Include all items indicated in Test Mode B in Fig. A1.1.

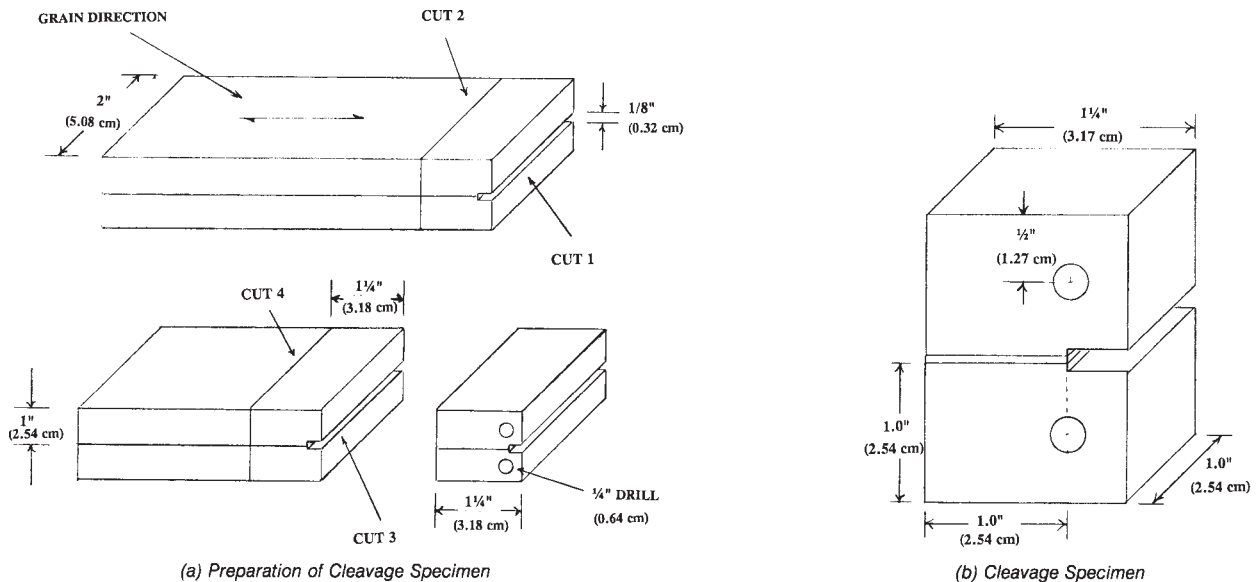

FIG. 14 Cutting and Drilling Schematic for Cleavage Assembly

10. Strength Testing in the Climbing-Drum-Peel Mode— Procedures for Making and Testing Specimens, Calculating, and Reporting of Results (See Test Method D 1781)

10.1 The selections of adherends and pressure modes available in this test mode are shown in Table 1, Table X1.1, Table X2.1 and in Appendix X1 and Appendix X2.

10.1.1 In this test mode one rigid and one flexible substrate are required. The combinations of adherends possible in this test mode are shown in Appendix X1. The strength of some of these materials may be inadequate for some autohesives under some test parameters. The materials rank as follows in decreasing order of strength: maple, Douglas-fir, and flakeboard. Plastic laminates can only be used in this test by first laminating the decorative face of the laminate to one of the above rigid materials, as in 7.7. The steel sheets prescribed for use as the rigid member are of the maximum thickness that can be held flat during application of the autohesive. Nevertheless, the climbing-drum-peel values sometimes encountered may exceed the capability of the rigid-steel member to withstand the test (Note 2).

NOTE 2—Steel is not recommended for testing water-borne adhesives due to flash oxidation.

10.2 Materials:

10.2.1 Precondition materials in the selected environment to equilibrium moisture content.

10.2.2 For dimensions see Table 1.

10.2.3 *Steel, Flexible, and Rigid Substrates*—See 7.5. The coating of each adherend requires one set of three sheets of identical thickness.

10.2.4 *Aluminum, Flexible Substrates*—See 7.6. In this mode it is recommended that aluminum be used only as the flexible substrate. Aluminum is too weak to withstand deformation and will pull out of the retaining lips of the fixture in Fig. 8 during the test.

10.3 Select the relative humidity and temperature for preconditioning of wood and flakeboard. (See also 8.2.)

10.3.1 These conditions may also be set by agreement between the user and the party requiring these tests. In the absence of any specific requirements, use the standard conditions $23 \pm 1^\circ\text{C}$ ($73 \pm 2^\circ\text{F}$) and $50 \pm 2\%$ relative humidity given in Practice D 1151.

10.3.2 Maintain this environment while performing the operations in 10.5, 10.6 (temperature only), 10.7, 10.8, 10.9, and 10.10.

10.4 *Surfacing of Wood and Precutting of Wood and Flakeboard, Reassembling of Materials*—Perform the operations in accordance with 8.4 and 8.4.1.

10.5 *Conditioning Materials Prior to Autohesive Application:*

10.5.1 *Wood and Flakeboard*—Perform the operations described in 8.5.

10.5.2 *Steel*—After cleaning or treating (see 7.5) condition sheets for 15 min in the environment selected in 10.3.

10.5.3 *Aluminum*—Prepare as in 7.6 and condition in the environment selected in 10.3 for a minimum of 15 min.

10.6 Condition the autohesive to the temperature as in 10.3.

10.7 *Autohesive Application, Beginning of the Open-Assembly Time:*

10.7.1 Apply to wood or flakeboard, or both, in accordance with 8.7.

10.7.2 *Application to Steel:*

10.7.2.1 *Application of Autohesive Using a Magnetic Table to Hold the Substrates Flat*—Use knife applicators as in Fig. 1. Coat the rigid member first. On a location free of air drafts, lay along the table three rigid sheets of identical thickness. Turn the magnet on. Apply the autohesive with a knife or bar applicator. Record the applicator's gap. Immediately after, turn the magnet off, separate the sheets, and lay along the table three flexible sheets of identical thickness. Bring all sheets tightly together edgewise. Turn the magnet on. With the same applicator, apply the autohesive to the flexible substrates as in the preceding step. The open-assembly time begins immediately after application to the flexible substrates. Note the time. Do not disturb the coated sheets for at least 5 min. Turn the magnet off. Very carefully separate the three sheets with a lateral pull to prevent edge defects (see 8.7). In these operations only the center sheets become adherends. Discard or clean the two other sheets for reuse. When a magnetic table is not available, the procedure in 10.7.2.2 can be used.

10.7.2.2 *Application of Autohesive in Wet-Film Thickness Up to 0.010 in. (0.025 mm) Using Glass Plate to Hold the Substrates Flat*—Use the wire-wound-rod applicators to hold the substrates flat during application. (For thicknesses > 0.010 in. (0.025 mm), knife applicators must be used.) Coat the rigid substrate first. On a location free of air drafts, lay one rigid sheet along the glass. Tape the leading edge of the sheet to the glass. Apply the autohesive. Record the type of applicator and wet-film thickness. Immediately after, lay along the glass three flexible sheets of identical thickness tightly together lengthwise. Tape all three sheets along the leading edges. Apply the autohesive with the same applicator to the flexible substrates as in the preceding step. The open-assembly time begins immediately after application to the flexible substrates. Note the time. Do not disturb the sheets for at least 5 min. Very carefully separate the three sheets with a lateral pull to prevent edge defects (see 8.7). In this operation, only the center sheet becomes the adherend. Discard or clean the two other sheets for reuse.

10.7.2.3 *Application of Autohesive in Wet-Film Thickness Up to and Greater Than 0.010 in. (0.025 mm) Using a Glass Plate to Hold the Substrates Flat*—Use only knife applicators similar to those in Fig. 1. Follow the same general procedure for rigid and flexible sheets as for the flexible sheets in 10.7.2.2, taking care that all sheets are taped down to the glass with double-coated pressure-sensitive tape so that all three sheets are in the same plane during application. Verify flatness as in 7.1.

10.7.3 *Application to Aluminum:*

10.7.3.1 *Application of Autohesive in Wet-Film Thickness Up to 0.010 in. (0.025 mm) Using Glass Plate to Hold the Substrates Flat*—Follow the procedure in 10.7.2.2 for the flexible sheets.

10.7.3.2 *Application of Autohesive in Wet-Film Thickness Up to and Greater Than 0.010 in. (0.025 mm) Using a Glass Plate to Hold the Substrates Flat*—Follow the procedure in 10.7.2.3.

10.8 *Conditioning the Coated Materials for the Duration of the Open-Assembly Time*—Place in an area protected from air drafts. Record the selected open-assembly time.

10.9 *Bonding the Coated Materials*—At the expiration of the open-assembly time lay the flexible sheet parallel to and onto the center of the rigid member, with the coated sides facing one another. Exert just enough hand pressure to make a handling bond. Record the selected open-assembly time.

10.10 *Application of Pressure:*

10.10.1 See the tables in Appendix X1 and Appendix X2. Pressure may be static, or applied by roller or impact.

10.10.1.1 *Roller Pressure*—Select one of the rollers specified in 6.6.2. Run the roller on the bonded assembly five times, taking care to keep the roller centered to the width of the assembly.

10.10.2 *Static Pressure*—Follow the procedure in 8.10.

10.10.3 *Impact*—Lay the specimen flat on the foot pad of the device prescribed in 6.6.3, and as shown in Fig. 4, Fig. 5. Adjust the air pressure on the impact device to the required impact energy. Record air pressure and impact energy. With the flexible adherend facing the impact pad, begin impacting at one end of the bonded section of the assembly. While the impact pad is lying on the assembly after the first impact, draw pencil marks on the assembly in a perpendicular direction to the length of the assembly, using the pad as a guide. Move the assembly to the next impact position, using the pencil marks as guides to prevent impacting on the same place twice. Calculate the energy of impact from the following formula:

$$\text{energy of impact per unit area} = \frac{P \times A \times D}{a} \quad (1)$$

where:

- P = air pressure, psi (N/cm²),
- A = cross-sectional area of the piston, in.² (cm²),
- D = stroke length, ft (m), and
- a = area impacted, in.² (cm²).

10.11 *Bond Conditioning*—Store the bonded assembly for the duration of the bond-conditioning time.

10.12 *Testing Procedure*—At the end of the bond-conditioning time perform the following:

10.12.1 Calibrate the test apparatus as in the applicable sections of Test Method D 1781.

10.12.2 If while peeling the specimen, the autohesive remains adhered to both the rigid and flexible adherends and as it strings-out, wraps itself around the drum, false readings will be obtained. The error can be minimized by cutting with a sharp knife close to the glue line as the specimen is peeled. Use quick strokes to avoid hitting the specimen itself and jarring the drum and load-measuring device.

10.12.3 If the strength of the autohesive causes the rigid-metal adherend to pull out of the fixture during the test, stop the test. Report the strength as greater than the peak autographic reading.

10.13 *Calculation*—Follow the applicable sections of Test Method D 1781.

10.14 *Report*—Include all items required in Test Mode C in Fig. A1.1.

11. Strength Testing in the T-Peel Mode—Procedures for Making and Testing Specimens, Calculating, and Reporting of Results (See Test Method D 1876)

11.1 The selections of adherends and pressure modes available in this test method are shown in Table 1 and in Appendix X1 and Appendix X2.

11.2 *Materials*—Twenty four pieces of the dimensions indicated in 7.1.1.

11.3 *Conditioning Materials Prior to Autohesive Application*—Select the relative humidity and temperature at which tests in 11.4, 11.5, 11.6, 11.7, and 11.8 shall be performed. These conditions may also be set by agreement between the user and the party requiring these tests. In the absence of any specific requirements, use the standard conditions 23 ± 1°C (73 ± 2°F) and 50 ± 2 % relative humidity given in Practice D 1151.

11.4 Condition the autohesive at the temperature in 10.3.

11.5 *Application of the Autohesive, Beginning of Open-Assembly Time:*

11.5.1 *Application to Steel and Aluminum*—Follow the instructions in 10.7.2 and 10.7.3 respectively.

11.6 *Conditioning the Coated Materials for the Duration of the Selected Open-Assembly Time*—Place in an area protected from air drafts. Maintain in this environment until the expiration of the open-assembly time.

11.7 *Bonding the Coated Materials*—At the expiration of the open-assembly time lay one sheet in perfect overlap to the other so that the coated sides make contact. Exert just enough finger pressure to make a handling bond. Record the selected open-assembly time.

11.8 *Application of Pressure*—Follow instructions in 10.10, 10.10.1, 10.10.2, and 10.10.3.

11.9 *Bond Conditioning*—Store the bonded assembly for the duration of the bond-conditioning time.

11.10 *Procedure and Calculation*—Perform the operations described in applicable sections of Test Method D 1876.

11.11 *Report*—Include all items indicated in Test Mode D in Fig. A1.1.

12. Keywords

12.1 autohesive; cleavage; climbing drum peel; compression shear; flexible-to-flexible adherends; flexible-to-rigid adherends; rigid-to-rigid adherends; T-peel

ANNEX**(Mandatory Information)****A1. CHARACTERIZATION OF AUTOADHESIVE BOND FORMATION**

A1.1 The bond-formation process of autohesives is characterized by the following unique differences: at the time when the bond is made, the autohesive exists as two distinct quasi-rigid films that cannot flow freely between the adherends, and their films are dry to the touch, not tacky, and are capable of bonding on contact only to like autohesive surfaces. The quasi-rigid nature of these films makes their topography of paramount importance in determining the degree of fit, the

extent to which the films coalesce at a given pressure and temperature, and consequently, the bond strength attained. Because the particular method used to apply the autohesive can, to a great extent, dictate the resulting topography of its films, the application method itself is one of the factors that determine the magnitude and reproducibility of the measured bond strength. Furthermore, the autohesive bonds, can be and often are formed by impacting the autohesive-coated materials.

| REPORT: <i>X= Requirements for each test mode</i> | (Mandatory Information) | | | | | |
|--|-------------------------|-----------------|-----------|----------|----------|--------|
| | UNITS | | TEST MODE | | | |
| | US | METRIC | Shear | Cleavage | CD -Peel | T-Peel |
| | | | A | B | C | D |
| Identification of the Adhesive Tested: manufacturers code numbers. | | | | | | |
| FORM | | | x | x | x | x |
| DATE RECEIVED | | | x | x | x | x |
| DATE TESTED | | | x | x | x | x |
| ADHEREND A: type, orientation, full description | | | x | x | x | x |
| ADHEREND B: type, orientation, full description | | | | | x | x |
| MECHANICAL SURFACE PREPARATION IF ANY | | | x | x | | |
| CHEMICAL SURFACE PREPARATION IF ANY | | | | | x | x |
| CONDITIONING PROCEDURE FOR MATERIALS PRIOR TO TESTING | | | x | x | x | x |
| TEMPERATURE During: application & open assembly time | | | x | x | x | x |
| bond-conditioning | | | x | x | x | x |
| testing | | | x | x | x | x |
| HUMIDITY During: application | | | x | x | x | x |
| bond-conditioning | | | x | x | x | x |
| testing | | | x | x | x | x |
| OPEN ASSEMBLY TIME | | | x | x | x | x |
| BOND CONDITIONING TIME | | | x | x | x | x |
| APPLICATOR TYPE | | | x | x | x | x |
| FILM THICKNESS APPLIED | | | x | x | x | x |
| METHOD USED FOR APPLICATION OF PRESSURE- One of the following: | | | x | x | x | x |
| a) Pressure applied -Hydraulic Press, time | psi, sec | MPa, sec | x | x | x | x |
| b) Impact energy | ft.lbf/sq.in. | Joules / sq. cm | | | x | x |
| c) Roller, state roller dimensions, -diameter, width, weight | in, lb | cm, kg | | | x | x |
| CROSSHEAD SPEED | in / sec | cm / sec | x | x | x | x |
| NUMBER OF SPECIMENS TESTED | | | x | x | x | x |
| SHEAR | | | | | | |
| Values for each specimen | psi | MPa | x | | | |
| Average, maximum and min. shear values | psi | MPa | x | | | |
| CLEAVAGE | | | | | | |
| Values for each specimen | lb/in width | k / cm width | | x | | |
| Average, maximum and min. values | lb/in width | k / cm width | | x | | |
| CLIMBING DRUM PEEL | | | | | | |
| Load Required to: | | | | | | |
| A) Wind drum and blank sheet up (CONTROL) | lb / in width | kg/mm width | | | x | |
| B) Wind drum and bonded sheet and peel adherend | lb / in width | kg/mm width | | | x | |
| C) Peel autohesive = B-A above. | lb / in width | kg/mm width | | | x | |
| D) Peel autohesive: Average, Max. and Min. for group of specimens | lb / in width | kg/mm width | | | x | |
| Torque Required for: | | | | | | |
| A) above (CONTROL) | in. lb / in | mm.kg / mm | | | x | |
| B) above | in. lb / in | mm.kg / mm | | | x | |
| C) above | in. lb / in | mm.kg / mm | | | x | |
| D) above | in. lb / in | mm.kg / mm | | | x | |
| T-PEEL | | | | | | |
| PEELING LOAD | | | | | | |
| Average max. and min. for each specimen | lb/in width | kg / cm width | | | | x |
| Average max. and min. for each group of specimens | lb/in width | kg / cm width | | | | x |
| STANDARD DEVIATION | | | x | x | x | x |
| REPORT FAILURE MODE AS A % FOR EACH SPECIMEN | | | | | | |
| Substrate | | | x | x | x | x |
| Adhesive | | | x | x | x | x |
| Cohesive | | | x | x | x | x |
| Autohesive (contact) | | | x | x | x | x |

FIG. A1.1 Reporting Requirements for Test Mode

APPENDIXES

(Nonmandatory Information)

X1. CHOICE OF ADHERENDS AVAILABLE IN EACH TEST MODE

X1.1 The possible combinations of adherends are limited to those shown in Table X1.1.

TABLE X1.1 Combinations of Adherends Available for Test Mode

| | Wood | Flakeboard | High-Pressure (HP) Laminates | Steel | Aluminum ^A |
|--------------|-------------------|------------|------------------------------|---------|-----------------------|
| Wood | Shear Cleavage | Shear | CD Peel ^A | CD Peel | CD Peel |
| Flakeboard | ... | Shear | Shear | CD Peel | CD Peel |
| HP Laminates | ... | ... | Shear Cleavage | CD Peel | CD Peel |
| Steel | ... | ... | ... | CD Peel | CD Peel |
| Aluminum | ... | ... | ... | T-Peel | T-Peel |

^AThe climbing-drum-peel test method (CD peel) requires that one of the two substrates be rigid and that when sheet materials are used, these should be sufficiently rigid to remain attached to the test fixture in Fig. 5 while the flexible member is peeled. Aluminum does not fulfill these conditions unless overly thick and costly sheets or blocks are used. Accordingly, it is used only as the flexible adherent.

X2. PRESSURE MODES AND SUBSTRATES AVAILABLE IN EACH TEST MODE

X2.1 For a particular combination of substrates, the means available for application of pressure are limited to those shown in Table X2.1: (Y = Yes).

TABLE X2.1 Means of Applying Pressure to Various Substrates for Test Mode

| Test Mode | ASTM Test Method | Pressure Mode | | | Substrates | | | | |
|--------------------|------------------|---------------|--------|--------|------------|------------|------------------|-------|----------|
| | | Static | Roller | Impact | Wood | Flakeboard | Plastic Laminate | Steel | Aluminum |
| Shear | D 905 | Y | ... | ... | Y | Y | Y | ... | ... |
| Cleavage | D 1062 | Y | ... | ... | Y | ... | Y | ... | ... |
| Climbing Drum Peel | D 1781 | Y | Y | Y | Y | Y | Y | Y | Y |
| T-Peel | D 1876 | Y | Y | Y | ... | ... | ... | Y | Y |

ASTM International takes no position respecting the validity of any patent rights asserted in connection with any item mentioned in this standard. Users of this standard are expressly advised that determination of the validity of any such patent rights, and the risk of infringement of such rights, are entirely their own responsibility.

This standard is subject to revision at any time by the responsible technical committee and must be reviewed every five years and if not revised, either reapproved or withdrawn. Your comments are invited either for revision of this standard or for additional standards and should be addressed to ASTM International Headquarters. Your comments will receive careful consideration at a meeting of the responsible technical committee, which you may attend. If you feel that your comments have not received a fair hearing you should make your views known to the ASTM Committee on Standards, at the address shown below.

This standard is copyrighted by ASTM International, 100 Barr Harbor Drive, PO Box C700, West Conshohocken, PA 19428-2959, United States. Individual reprints (single or multiple copies) of this standard may be obtained by contacting ASTM at the above address or at 610-832-9585 (phone), 610-832-9555 (fax), or service@astm.org (e-mail); or through the ASTM website (www.astm.org).