



Designation: D 3498 – 01

Standard Specification for Adhesives for Field-Gluing Plywood to Lumber Framing for Floor Systems¹

This standard is issued under the fixed designation D 3498; the number immediately following the designation indicates the year of original adoption or, in the case of revision, the year of last revision. A number in parentheses indicates the year of last reapproval. A superscript epsilon (ϵ) indicates an editorial change since the last revision or reapproval.

1. Scope

1.1 This specification covers minimum performance standards and test requirements for gap-filling construction adhesives for bonding plywood to lumber framing, particularly floor joists, at the construction site.

1.2 This specification provides a basis for ensuring the quality of the adhesives and is not intended as an application specification.

1.3 The values stated in inch-pound units are to be regarded as the standard. The values given in parentheses are for information only.

1.4 The following precautionary caveat pertains only to the test method portion, Section 11, of this specification: *This standard does not purport to address all of the safety concerns, if any, associated with its use. It is the responsibility of the user of this standard to establish appropriate safety and health practices and determine the applicability of regulatory limitations prior to use.*

2. Referenced Documents

2.1 ASTM Standards:

D 572 Test Method for Rubber—Deterioration by Heat and Oxygen²

D 905 Test Method for Strength Properties of Adhesive Bonds in Shear by Compression Loading³

D 907 Terminology of Adhesives³

D 1174 Test Method for Effect of Bacterial Contamination on Permanence of Adhesive Preparations and Adhesive Bonds⁴

D 1286 Test Method for Effect of Mold Contamination on Permanence of Adhesive Preparations and Adhesive Bonds⁴

¹ This specification is under the jurisdiction of ASTM Committee D14 on Adhesives and is the direct responsibility of Subcommittee D14.70 on Construction Adhesives.

Current edition approved Oct. 10, 2001. Published December 2001. Originally published as D 3498 – 76. Last previous edition D 3498 – 99.

² *Annual Book of ASTM Standards*, Vol 09.01.

³ *Annual Book of ASTM Standards*, Vol 15.06.

⁴ Discontinued; see *1983 Annual Book of ASTM Standards*, Vol 15.06.

D 2016 Test Methods for Moisture Content of Wood⁵

E 4 Practices for Force Verification of Testing Machines⁶

E 177 Practice for Use of the Terms Precision and Bias in ASTM Test Methods⁷

3. Terminology

3.1 *Definitions*—Many terms in this specification are defined in Terminology D 907.

3.1.1 *gap-filling adhesive, n*—an adhesive capable of forming and maintaining a bond between surfaces that are not close-fitting.

3.1.1.1 *Discussion*—Close-fitting is relative to a given material and industry; for example, standards in construction differ from standards in electronics. Some adhesives will bond by bridging without completely filling the gap; others by filling the gap completely.

3.1.2 *open assembly time, n*—the time interval between applying adhesive on the substrates and closing them together before bonding.

4. Significance and Use

4.1 This specification establishes test methods and performance requirements for adhesives bonding plywood to wood framing members.

4.2 This specification provides a basis for ensuring the quality of the adhesives.

4.3 The tests provide shear strength performance data when the substrates are conditioned to simulate various conditions that may occur during sub-floor adhesive application and curing.

4.4 The tests are suitable for product performance certification and quality control programs, and can be useful to the general public, adhesive manufacturers, distributors, specifiers, architects, contractors, testing laboratories and other businesses and professionals.

4.5 The results do not include all possible conditions, which

⁵ Discontinued; see *1989 Annual Book of ASTM Standards*, Vol 04.09.

⁶ *Annual Book of ASTM Standards*, Vol 03.01

⁷ *Annual Book of ASTM Standards*, Vol 14.02.



may occur during final assembly, but indicate a set of performance characteristics for laboratory controlled bonding variables.

5. Ordering Information

5.1 The adhesive may be furnished by the manufacturer in any suitable form agreeable to the purchaser.

6. Materials

6.1 The adhesive shall be a gap-filling construction adhesive that sets at temperatures as low as 40°F (4.4°C).

6.2 The adhesive shall not support mold or bacterial growth. If the adhesive contains any materials that will support mold or bacterial growth, such as amylaceous or protein fillers, the adhesive must not only pass requirements of this specification, but in addition, show no significant loss in strength at the 0.05 level of probability when tested for mold and bacterial contamination in accordance with Test Methods D 1174 and D 1286, and procedures contained in this specification. The adhesive manufacturer shall notify in writing the agency responsible for testing, certifying, and compliance labeling of the adhesive whether any such materials are present in the adhesive.

6.3 The adhesive, when completely set, shall form a resilient bond that shall be durable when protected from direct exposure to the weather, as defined by the requirements of this specification.

6.4 The adhesive shall be a uniform mixture suitable for extrusion by a caulking gun or other pressurized application equipment.

6.5 The adhesive shall permit an open assembly time of not less than 10 min when applied to the lumber framing in accordance with the manufacturer's instructions. It shall be functional, as defined in this specification, when applied to surfaces having a temperature range from 0 to 100°F (−17.8 to 37.8°C).

NOTE 1—Open assembly times that are less than 10 min as agreed upon between the manufacturer and user, are acceptable provided the adhesive

meets the requirements of Table 1.

6.6 The adhesive shall be functional when applied to lumber framing free of standing water, ice, or snow.

7. Requirements

7.1 The adhesive shall conform to the strength and durability properties shown in Table 1.

8. Sampling

8.1 A representative sample totaling not less than 1 qt (946 cm³) of the adhesive shall be taken from each lot to be tested.

8.2 For the purpose of sampling, a lot shall consist of material from the same batch or blending operation subject to the same processing operations and conditions.

9. Number of Tests

9.1 The number of test specimens shall be as specified in each test method designated in Section 11 and Table 1. The average result for the specimens tested shall conform to the requirements prescribed in this specification.

10. Specimen Preparation

10.1 *Materials*—Use the following materials for the tests outlined:

10.1.1 *Plywood*— $\frac{5}{8}$ -in. or ($\frac{19}{32}$ -in. (15.1-mm) thick, U.S. Product Standard PS-1-95 grade marked stamped, commercial plywood, Group 1 Species, exterior glue, or sanded exterior-grade plywood, underlayment type with A grade face ply for the adhesion surface. The plywood must be flat within $\frac{1}{16}$ in. (2 mm); that is, the maximum permissible bow for a 16-in. (406-mm) length of plywood shall be $\frac{1}{16}$ in. (2 mm). Make the measurement across the top surface of the plywood. Use bowed plywood only if it meets the limitation above and if the convexity occurs on the bottom surface that will contact the lumber. The plywood must be free of patches, core voids, and knot holes in the glue area.

10.1.2 *Lumber*—2-in. (51-mm) (nominal) Douglas-fir and southern pine; (Note 2) clear dry lumber (moisture content of

TABLE 1 Adhesive Strength and Durability Requirements

Test	Property	Number of Specimens	Requirement	Section Reference
Test A (wet lumber)				
Douglas-fir	shear strength	24	150 psi (1.035 MPa), min avg	11.2
Southern pine	shear strength	24	150 psi (1.035 MPa), min avg	11.2
Test B (frozen lumber)				
Douglas-fir	shear strength	24	100 psi (0.689 MPa), min avg	11.2
Southern pine	shear strength	24	100 psi (0.689 MPa), min avg	11.2
Test C (dry lumber)				
Douglas-fir	shear strength	24	150 psi (1.035 MPa), min avg	11.2
GAP-filling				
Douglas-fir	shear strength	24	100 psi (0.689 MPa), min avg	11.3
Durability (moisture resistance)				
Douglas-fir	delamination	24	a minimum of 22 of 24 specimens shall show no delamination.	11.4
	shear strength	24	150 psi (1.035 MPa), min avg	11.4
Durability (oxidation resistance)	flexibility	3	no fracture of free film on mandrel bend or visible signs of melting after exposure	11.5
Mold resistance				
Douglas-fir	shear strength	48	no significant loss in average strength at the 0.05 level of probability.	11.6
Bacterial resistance				
Douglas-fir	shear strength	48	no significant loss in average strength at the 0.05 level of probability.	11.7

12 to 19 %) (Note 3). The surface shall be free of bark, knots, splits, and pitch.

NOTE 2—Only the sapwood of loblolly, slash, longleaf, and shortleaf pine may be used.

NOTE 3—Test Methods D 2016 can be used to determine moisture content.

10.1.3 *Adhesive*—applied with a caulking gun.

10.2 *Number of Test Assemblies*—Prepare three wood-adhesive composite test assemblies as shown in Fig. 1 for each condition specified.

10.3 *Conditioning of Materials:*

10.3.1 Cut lumber and plywood to the required size as shown in Fig. 1. If the lumber must be reduced in height, retain at least one mill-finished surface as the surface to be bonded. If the lumber must be reduced in width to achieve a maximum 1½-in. (38-mm) dimension, plane both sides in equal amounts.

10.3.2 Predrill the plywood and lumber with a No. 37 (diameter 0.104 in. (2.64 mm)) to receive nails as shown in Fig. 1. Predrill the lumber to a depth of 1 in. (25 mm).

10.3.3 Condition the adhesive at 70 ± 5°F (21.1 ± 2.8°C) for a period of 48 h prior to use.

10.3.4 Condition the lumber and plywood in accordance with the schedules shown in Table 2, and the following procedures:

10.3.4.1 Run Test A (wet lumber) and Test B (frozen lumber) with both Douglas-fir and southern pine lumber.

10.3.4.2 Before fabricating samples with wet lumber surfaces (Test A), seal both ends of the lumber sections with paraffin. Completely submerge the lumber in water at 70 ± 5°F (21.1 ± 2.8°C) for 48 h for Douglas-fir, and for 2 h for southern pine. After submersion, wipe off visible surface water and expose the lumber for 48 h at 100 ± 5°F (37.8 ± 2.8°C), and 90 ± 5 % relative humidity. At the completion of the humidity cycle, submerge the lumber in water at 70 ± 5°F (21.1 ± 2.8°C) for 15 min. Wipe off visible surface water with a clean, dry cloth and immediately begin the fabrication procedure as outlined in 10.4.1.

10.3.4.3 Seal lumber for test assemblies with frozen lumber surfaces (Test B) at both ends with paraffin and submerge in water as described in Table 2. After submersion, wipe off visible surface water with a clean, dry cloth and store immediately at 0 ± 5°F (−17.8 ± 2.8°C) for 48 h.

NOTE 4—For safety, conditioning chambers should have no ignition sources within the vapor space.

10.4 *Preparation of Shear Strength Specimens:*

10.4.1 Apply an adhesive bead along the center line of a mill-finished surface of the lumber, such that the bead extends from one predrilled hole to the other, but not beyond. Apply sufficient adhesive to give 100 % coverage of the lumber surface, as evidenced by a “squeeze-out.” If it is necessary to apply the adhesive outside of the lumber conditioning chamber, remove only one piece of lumber at a time, apply the adhesive bead, then condition the lumber with adhesive applied for a minimum of 10 min and a maximum of 12 min in accordance with Table 3.

10.4.2 Before placing the plywood on the adhesive-covered surface, insert spacers, ¼ in. wide by 0.006 in. thick by 4 in. long (6 by 0.15 by 102 mm), at the midpoint of the lumber and at the outboard side of each nail, as shown in Fig. 2. Before the spacer is inserted at the midpoint, scrape away a 1-in. (25-mm) segment of the adhesive bead at the midpoint. Do not permit adhesive between the spacer and substrate.

NOTE 5—Aluminum embossing tape is suggested for use as spacers.

10.4.3 Position the plywood on the adhesive-covered surface with the aid of a positioning jig as shown in Fig. 3. Nail in place with 6-penny (2 in. (51 mm) in length) scaffold nails. Make the top of the lower head of a scaffold nail flush with the surface of the plywood.

10.4.4 Apply a uniform pressure of 4 ± 0.25 psi (28 ± 2 kPa) across the entire bonded area of the assembly for a period of 1 min at 70 ± 5°F (21.1 ± 2.8°C). Apply this pressure by any appropriate means, including a press with a suitable insert between the nails or a combination of uniformly distributed weights between the nails.

10.4.5 Set the adhesive in the assemblies in accordance with the schedules shown in Table 4.

10.4.6 After the specified setting time, remove the nails, but leave the spacers in place. Using a sharp saw, cut off the plywood flush with the side surfaces of the lumber, at the same time removing any excess adhesive. Cut eight block-shear specimens from each assembly as shown in Figs. 4 and 5.

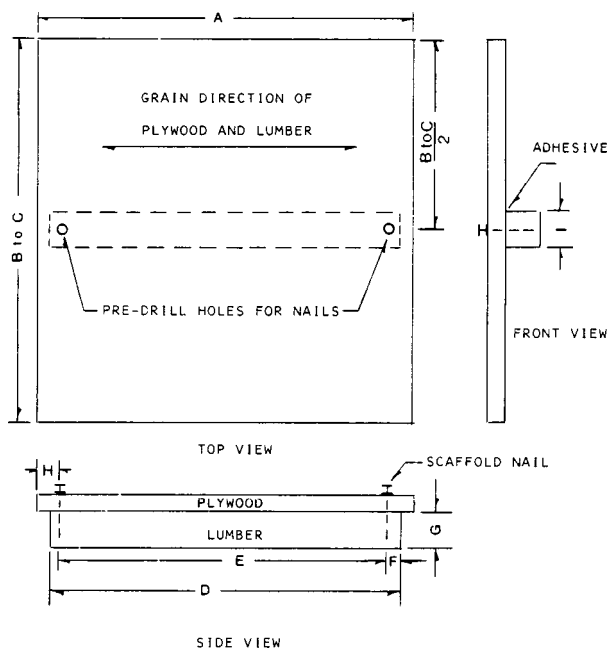

Table of Dimensions

	in.		mm	
	Dimension	Tolerance	Dimension	Tolerance
A	15¾	⅛	400	3
B	5½	...	140	...
C	16	...	406	...
D	15	⅛	381	3
E	13	⅛	330	3
F	1	⅛	25	3
G	1½min	⅛	38 min	2
H	1⅝	⅛	33	2
I	1½max	⅛	38 max	2

FIG. 1 Test Assembly

TABLE 2 Conditioning of Materials before Fabrication of Test Assemblies

Test	Lumber		Plywood
	Douglas-fir	Southern Pine	
Test A (wet lumber)	48 h soak in water at 70 ± 5°F (21.1 ± 2.8°C), then 48 h at 100 ± 5°F (37.8 ± 2.8°C) and 90 ± 5 % RH, then 15-min soak in water at 70 ± 5°F (21.1 ± 2.8°C)	2 h soak in water at 70 ± 5°F (21.1 ± 2.8°C), then 48 h at 100 ± 5°F (37.8 ± 2.8°C) and 90 ± 5 % RH, then 15 min soak in water at 70 ± 5°F (21.1 ± 2.8°C)	48 h at 100 ± 5°F (37.8 ± 2.8°C) and 90 ± 5 % RH
Test B (frozen lumber)	48 h soak in water at 70 ± 5°F (21.1 ± 2.8°C), then 48 h at 0 ± 5°F (-17.8 ± 2.8°C), with RH uncontrolled	2 h soak in water at 70 ± 5°F (21.1 ± 2.8°C), then 48 h at 0 ± 5°F (-17.8 ± 2.8°C), with RH uncontrolled	48 h at 0 ± 5°F (-17.8 ± 2.8°C), with RH uncontrolled
Test C (dry lumber)	48 h at 100 ± 5°F (37.8 ± 2.8°C) and RH max of 40 %	...	same as lumber
Gap-filling	48 h at 70 ± 5°F (21.1 ± 2.8°C) and 50 ± 10 % RH	...	same as lumber
Durability (moisture resistance)	48 h at 70 ± 5°F (21.1 ± 2.8°C) and 50 ± 10 % RH	...	same as lumber
Mold resistance	48 h at 70 ± 5°F (21.1 ± 2.8°C) and 50 ± 10 % RH	...	same as lumber
Bacterial resistance	48 h at 70 ± 5°F (21.1 ± 2.8°C) and 50 ± 10 % RH	...	same as lumber

TABLE 3 Open Assembly Time Conditions

Test	Temperature	Humidity
Test A (wet lumber)	70 ± 5°F (21.1 ± 2.8°C)	50 ± 10 % RH
Test B (frozen lumber)	0 ± 5°F (-17.8 ± 2.8°C)	RH uncontrolled
Test C (dry lumber)	100 ± 5°F (37.8 ± 2.8°C)	40 % RH max
Gap-filling	70 ± 5°F (21.1 ± 2.8°C)	50 ± 10 % RH
Durability (moisture resistance)	70 ± 5°F (21.1 ± 2.8°C)	50 ± 10 % RH
Mold resistance	70 ± 5°F (21.1 ± 2.8°C)	50 ± 10 % RH
Bacterial resistance	70 ± 5°F (21.1 ± 2.8°C)	50 ± 10 % RH

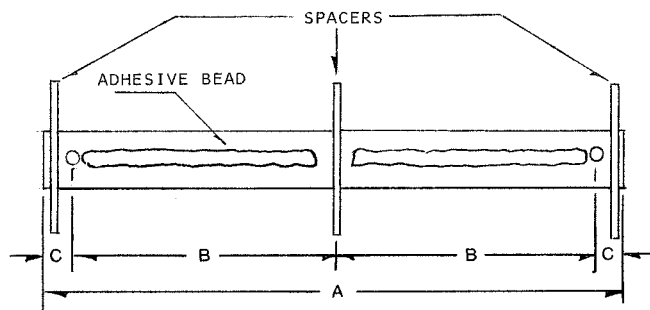

PLACEMENT OF ¼ IN. WIDE BY 0.006 IN. THICK BY 4 IN. LONG (6.00 X 0.15 X 102.00 MM) SPACERS FOR TESTS A, B, C AND DURABILITY (MOISTURE RESISTANCE) AND ¼ IN. WIDE BY 0.062 IN. THICK BY 4 IN. LONG (6.00 X 1.57 X 102.00 MM) SPACERS FOR GAP-FILLING TEST

Table of Dimensions

Dimension	in.		mm	
	Dimension	Tolerance	Dimension	Tolerance
A	15	1/8	381	3
B	6½	1/8	165	3
C	1	1/8	25	3
D	13	1/8	330	3

FIG. 2 Placement of Spacers in Test Assemblies

adhesive on top of the first film using the 0.100-in. (2.54-mm) gap of the spreader.

NOTE 7—For adhesives having solids contents in the range from 95 to 100 weight %, the wet film of adhesive may be cast in one step using the 0.100-in. (2.54-mm) gap of the spreader.

10.7.2 Set the completed casting of adhesive at the conditions shown in Table 4. After setting, cut three, 1 by 3-in. (25 by 76-mm) specimens from the free adhesive films.

10.8 Preparation of Specimens for Test of Mold Resistance—Prepare six test assemblies as described in 10.4.1-10.4.4. After the specified setting time (Table 4), remove the

10.5 Preparation of Specimens for Test of Gap-Filling Effect on Strength—Prepare assemblies as described in 10.4.1-10.4.4, except for thickness of spacers. Before placing the plywood on the adhesive-covered lumber surface, insert spacers, ¼ in. wide by 0.062 in. thick by 4 in. long (6 by 1.57 by 102 mm), as shown in Fig. 2. Avoid disturbing the location of the spacers. Do not permit adhesive between the spacer and substrate.

NOTE 6—TFE-fluorocarbon sheet is suggested for use as spacers.

10.5.1 After the specified setting time (Table 4), remove the nails and spacers before cutting eight block-shear specimens from each assembly, as shown in Figs. 4 and 5.

10.6 Preparation of Specimens for Test of Durability (Moisture Resistance)—Prepare assemblies as described in 10.4.1-10.4.4. After the specified setting time (Table 4), remove the nails, but leave the spacers in place. Cut eight specimens from each assembly as shown in Fig. 4 and Fig. 6.

10.7 Preparation of Specimens for Test of Durability (Oxidation Resistance).

10.7.1 Prepare specimens by casting wet films of adhesive lengthwise on silicone release paper or polyethylene sheet, as shown in Fig. 7. Control thickness and width of the castings with the spreader shown in Fig. 7. Cast the first film of adhesive using the 0.050-in. (1.27-mm) gap of the spreader. Condition this film for 3 h at 70 ± 5°F (21.1 ± 2.8°C) and 50 ± 10 % relative humidity. Then cast a second wet film of

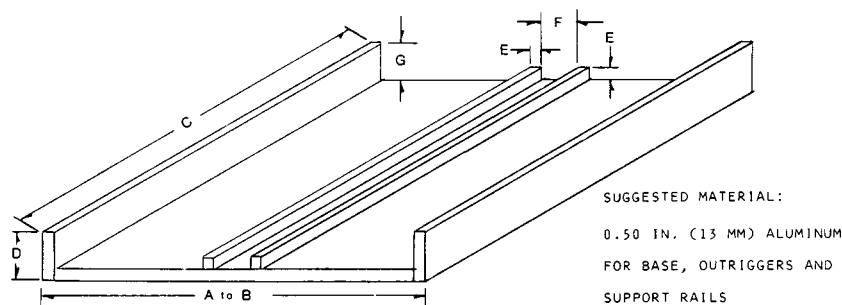

Table of Dimensions

Dimension	in.		mm	
	Dimension	Tolerance	Dimension	Tolerance
A	16	...	406	—
B	5½	...	140	—
C	15¾	⅛	400	3
D	2 max	¼₁₆	51 max	2
E	½	¼₁₆	13	2
F	1½min	¼₁₆	38 min	2
G	1½max	¼₁₆	38 max	2

FIG. 3 Aluminum Jig for Test Assembly

TABLE 4 Setting Conditions for Test Assemblies

Test	Setting Conditions	Section Reference
Test A (wet lumber)	28 days at 100 ± 5°F (37.8 ± 2.8°C) and 90 ± 5 % RH	10.4.5
Test B (frozen lumber)	7 days at 0 ± 5°F (-17.8 ± 2.8°C), RH uncontrolled, then 21 days at 40 ± 5°F (4.4 ± 2.8°C), RH uncontrolled, then 7 days at 70 ± 5°F (21.1 ± 2.8°C), and 50 ± 10 % RH	10.4.5
Test C (dry lumber)	28 days at 70 ± 5°F (21.1 ± 2.8°C) and 50 ± 10 % RH	10.4.5
Gap-filling	28 days at 70 ± 5°F (21.1 ± 2.8°C) and 50 ± 10 % RH	10.5
Durability (moisture resistance)	28 days at 70 ± 5°F (21.1 ± 2.8°C) and 50 ± 10 % RH	10.6
Durability (oxidation resistance)	3 days at 70 ± 5°F (21.1 ± 2.8°C) and 50 ± 10 % RH, then 2 days at 120 ± 5°F (49 ± 2.8°C) and RH max of 40 %	10.7
Mold resistance	28 days at 70 ± 5°F (21.1 ± 2.8°C) and 50 ± 10 % RH	10.8
Bacterial resistance	28 days at 70 ± 5°F (21.1 ± 2.8°C) and 50 ± 10 % RH	10.9

nails but leave the spacers in place. Cut eight block-shear specimens from each assembly as shown in Figs. 4 and 5. Randomly assign one half of the 48 specimens to a control group and the other half to a group for inoculation with mold fungi.

10.9 *Preparation of Specimens for Test of Bacterial Resistance*—Prepare six test assemblies as described in 10.4.1-10.4.4. After the specified setting time (Table 4), remove the nails but leave the spacers in place. Cut eight block-shear specimens from each assembly as shown in Fig. 4 and Fig. 5. Randomly assign one half of the 48 specimens to a control group and the other half to a group for inoculation with bacteria.

11. Test Methods

11.1 *Test Conditions*—Perform all tests of shear strength at 70 ± 5°F (21.1 ± 2.8°C) and 50 ± 10 % relative humidity. Maintain the specimens at these conditions after removal from the setting area, and test within 8 h after setting has been completed.

11.2 *Shear Strength (Tests A, B, and C)*— Test the specimens for shear strength by compression-shear loading in a testing machine that has an accuracy of ±1 % when calibrated in accordance with Practices E 4. Use a loading rate of 0.20 in.

(5 mm)/min. A shearing tool described in Test Method D 905 is recommended for these tests, but other equipment may be used, including loading devices that apply compression loads in tension testing machines. The ultimate load for each condition (Tests A and B, each wood species, and Test C) shall be read to the nearest 1 lbf (0.45 N) for each of the 24 specimens (three assemblies per test condition, eight specimens per assembly). After testing, determine the overall bonded area of each test specimen by measuring it, at least once in each dimension, to the nearest 0.010 in. (0.25 mm). Report the shear strengths in pounds-force per square inch (megapascals) for each specimen, together with the overall average of the 24 specimens for each test condition, and for each wood species in Tests A and B.

11.3 *Gap-Filling Effect on Strength*— Test the 24 specimens as described in 11.2. Report the shear strengths in pounds-force per square inch (megapascals) for each specimen, together with the overall average of the 24 specimens.

11.4 *Durability (Moisture Resistance)*— This test is to be run with Douglas-fir lumber only.

11.4.1 Place the specimens in a vacuum-pressure vessel and weight them. Introduce water at 110 ± 5°F (43 ± 2.8°C) until the specimens are completely submerged. Draw a vacuum of 15 in. (381 mm) Hg (51 kPa) and maintain it for 30 min. Release the vacuum and continue to soak the specimens in the

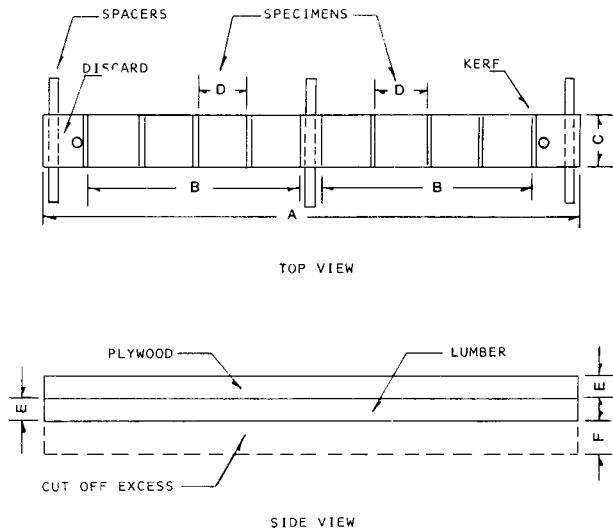

Table of Dimensions

in.		mm	
Dimension	Tolerance	Dimension	Tolerance
A	15	381	3
B	6	152	3
C	1½max	38 max	2
D	1¾	35	1
E	5/8	16	1
F	7/8	22	1

FIG. 4 Method of Cutting and Numbering Specimens in Assemblies

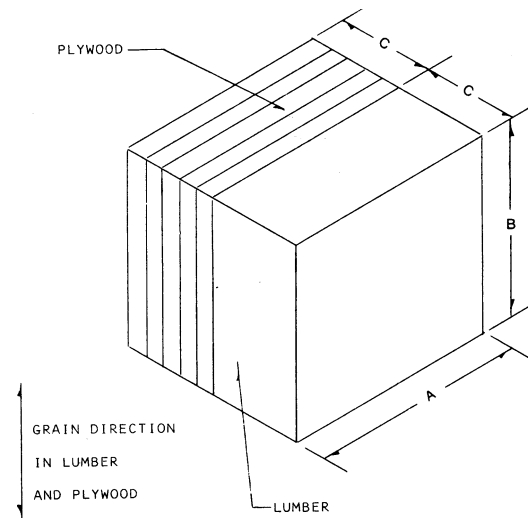

Table of Dimensions

in.		mm	
Dimension	Tolerance	Dimension	Tolerance
A	1½max	38 max	2
B	1¾	35	1
C	5/8	16	1

FIG. 6 Specimen for Test of Durability (Moisture Resistance)

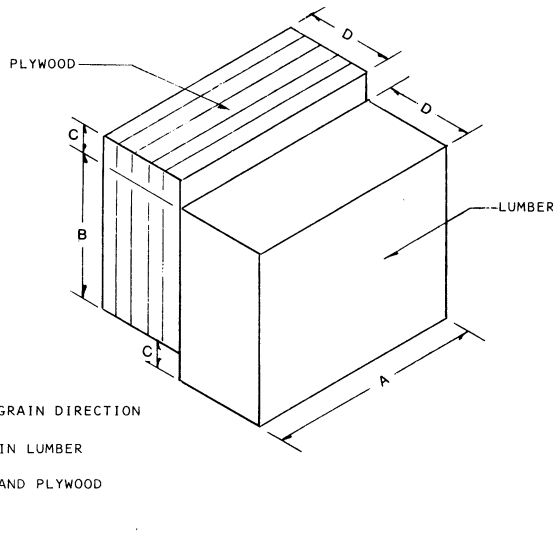

Table of Dimensions

in.		mm	
Dimension	Tolerance	Dimension	Tolerance
A	1½max	38 max	2
B	1	25	1
C	3/16	5	1
D	5/8	16	1

FIG. 5 Block-Shear Specimen

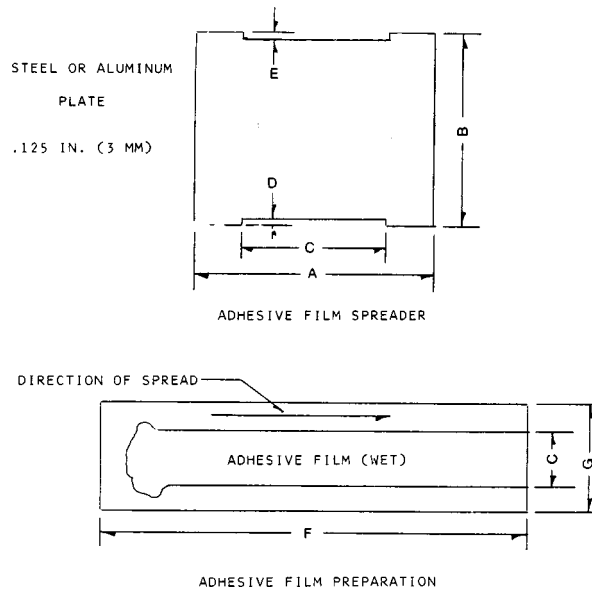

Table of Dimensions

in.		mm	
Dimension	Tolerance	Dimension	Tolerance
A	2½	63	2
B	2	51	2
C	1.50	38	1
D	0.100	2.54	0.05
E	0.050	1.27	0.05
F	12	305	13
G	3	76	6

FIG. 7 Specimen Preparation for Test of Durability (Oxidation Resistance)

same water at atmospheric pressure for 4½ h with no additional heating. Remove specimens from water, then dry them for 16 h in an oven at 150 ± 5°F (66 ± 2.8°C) with forced-air circulation at 45 to 50 air changes per minute.

11.4.2 Immediately after drying, examine the edges of the specimens for adhesive bond failure (delamination) to the plywood or lumber. Voids in the adhesive bond shall not be

considered delamination. Report the number of specimens with and without visible delamination.

11.4.3 After examining the specimens for adhesive bond failure, condition them at $70 \pm 5^\circ\text{F}$ ($21.1 \pm 2.8^\circ\text{C}$) and $50 \pm 10\%$ relative humidity for 7 days and prepare them as block-shear specimens as shown in Fig. 5. Test the specimens as described in 11.2 to evaluate any degradation in shear strength after exposure to moisture. Report the shear strength in pounds-force per square inch (megapascals) for each specimen, together with the overall average of the 24 specimens. The shear strength of any specimens that came apart during the moisture resistance test, report as 0 psi (0 MPa) and include in the average.

11.5 *Durability (Oxidation Resistance):*

11.5.1 Suspend the adhesive specimens vertically in an oxygen atmosphere at $158 \pm 2^\circ\text{F}$ ($70 \pm 1.1^\circ\text{C}$) and 300 ± 15 psi (2.07 ± 0.10 MPa) pressure for 500 h. Provide a separate test atmosphere for each adhesive. The apparatus and test procedure are described in Test Method D 572. Note that, in relieving the pressure from the oxygen pressure chamber preparatory to removing the specimens, it is essential that the release be slow and uniform, requiring at least 5 min, so as to avoid possible formation of porosity in the specimen.

11.5.2 After exposure, condition the specimens, with minimum handling, at $70 \pm 5^\circ\text{F}$ ($21.1 \pm 2.8^\circ\text{C}$) and $50 \pm 10\%$ relative humidity for 24 h before testing. Then, bend the specimens 180° around a 0.25-in. (6.4-mm) mandrel to test for brittleness.

11.5.3 None of the three specimens shall break to pass the requirements of this specification. Surface checks shall not constitute failure. In addition, none of the three specimens shall exhibit visible evidence of having melted during the exposure period.

11.6 *Mold Resistance*—Determine the effect of mold contamination on the permanence of adhesive bonds by comparing the average shear strengths of 24 uncontaminated (control) specimens with 24 contaminated (inoculated) specimens after 28 days of incubation. Prepare specimens in accordance with 10.8 of this specification. Prepare cultures of mold fungi in accordance with the Apparatus and Materials through Preservation of Cultures Sections in Test Method D 1286. Then inoculate and incubate specimens with cultures of mold fungi in accordance with the Inoculation of Specimens and Incubation Sections in Test Method D 1286. After 28 days of incubation of inoculated and control specimens in desiccators in the constant-temperature chamber, remove both groups of specimens and condition them separately for 1 week at $70 \pm 5^\circ\text{F}$ ($21.1 \pm 2.8^\circ\text{C}$) and $50 \pm 10\%$ relative humidity. Test the specimens for shear strength as directed in 11.2 of this specification. Using a “t” test for unpaired replicates, determine if there is any significant difference between the average shear strengths of inoculated and control specimens when tested at the 0.05 level of probability. Report the results of the “t” test along with the shear strengths in pounds-force per square inch (megapascals) for each specimen and the average of the 24 specimens in each group.

11.7 *Bacterial Resistance*—Determine the effect of bacterial contamination on the permanence of adhesive bonds by com-

paring the average shear strengths of 24 uncontaminated (control) specimens with 24 contaminated (inoculated) specimens after 28 days of incubation. Prepare specimens in accordance with 10.9 of the specification. Prepare cultures of bacteria in accordance with the Apparatus through Incubation Sections in Test Method D 1174. Then inoculate and incubate specimens with cultures of bacteria in accordance with the Conditioning of Test Specimens Before Inoculation and Inoculation of Specimens Sections in Test Method D 1174. After 28 days of incubation of inoculated and control specimens in desiccators in the constant-temperature chamber, remove both groups of specimens and condition them separately for 1 week at $70 \pm 5^\circ\text{F}$ ($21.1 \pm 2.8^\circ\text{C}$) and $50 \pm 10\%$ relative humidity. Test the specimens for shear strength as directed in 11.2 of this specification. Using a “t” test for unpaired replicates, determine if there is any significant difference between the average shear strengths of inoculated and control specimens when tested at the 0.05 level of probability. Report the results of the “t” test along with the shear strengths in pounds-force per square inch (megapascals) for each specimen and the average of the 24 specimens in each group.

12. Retest and Rejection

12.1 If the results of any test do not conform to the requirements prescribed in this specification, at the option of the manufacturer, that test shall be repeated on two additional sets of specimens from the same lot of adhesive, each of which shall conform to the requirements specified. If either of these two additional sets of specimens fails to meet the requirements, the lot or batch of material may be rejected at the option of the purchaser. Notice of failure of material based on tests made in accordance with this specification shall be reported to the manufacturer.

13. Certification

13.1 Upon request of the purchaser in the contract or order, a manufacturer’s certification that the adhesive was manufactured and tested in accordance with this specification together with a report of the test results shall be furnished at the time of shipment.

14. Packaging and Marking

14.1 *Packaging*—The material shall be packaged in standard commercial containers, so constructed as to ensure acceptance by common or other carrier for safe transportation at the lowest rate to the point of delivery, unless otherwise specified in the contract or order.

14.2 *Marking*—Shipping containers shall be marked with the following information:

14.2.1 Manufacturer’s name, product code number, and batch lot number,

14.2.2 Date of manufacture of the product,

14.2.3 Special handling instructions during product transfer, and

14.2.4 Special precautions required because of product toxicity, flammability, or such information pertinent to the proper handling and storage of the product.



15. Precision and Bias⁸

15.1 The precision information given below is in the units of measurement (psi), each of which is the average of ten test determinations:

Average	Sr ^A	SR ^B	r ^C	R ^D
464	127	138	354	386

^A Repeatability Standard Deviation.

^B Reproducibility Standard Deviation.

^C 95 % Repeatability Limit (within a laboratory).

^D 95 % Reproducibility Limit (between laboratories).

15.2 The table was calculated using the relationship:

$$95 \% \text{ Limit} = 2.8 \times \text{standard deviation.}$$

15.3 The term repeatability and reproducibility limits are used as specified in Practice E 177.

16. Keywords

16.1 adhesives; bacteria resistance; durability; gap-filling; mold-resistance; oxidation resistance; shear strength

⁸ Supporting data are available from ASTM International Headquarters. Request RR: D14-1009.

ASTM International takes no position respecting the validity of any patent rights asserted in connection with any item mentioned in this standard. Users of this standard are expressly advised that determination of the validity of any such patent rights, and the risk of infringement of such rights, are entirely their own responsibility.

This standard is subject to revision at any time by the responsible technical committee and must be reviewed every five years and if not revised, either reapproved or withdrawn. Your comments are invited either for revision of this standard or for additional standards and should be addressed to ASTM International Headquarters. Your comments will receive careful consideration at a meeting of the responsible technical committee, which you may attend. If you feel that your comments have not received a fair hearing you should make your views known to the ASTM Committee on Standards, at the address shown below.

This standard is copyrighted by ASTM International, 100 Barr Harbor Drive, PO Box C700, West Conshohocken, PA 19428-2959, United States. Individual reprints (single or multiple copies) of this standard may be obtained by contacting ASTM at the above address or at 610-832-9585 (phone), 610-832-9555 (fax), or service@astm.org (e-mail); or through the ASTM website (www.astm.org).