

This document is not an ASTM standard and is intended only to provide the user of an ASTM standard an indication of what changes have been made to the previous version. Because it may not be technically possible to adequately depict all changes accurately, ASTM recommends that users consult prior editions as appropriate. In all cases only the current version of the standard as published by ASTM is to be considered the official document.



Designation: D 3929 – 96^{€1}



Designation: D 3929 – 03

Standard Test Method for Evaluating Stress Cracking of Plastics by Adhesives Using the Bent-Beam Method¹

This standard is issued under the fixed designation D 3929; the number immediately following the designation indicates the year of original adoption or, in the case of revision, the year of last revision. A number in parentheses indicates the year of last reapproval. A superscript epsilon (ϵ) indicates an editorial change since the last revision or reapproval.

~~¹ Note—Editorial changes were made throughout in June 1997.~~

¹ This test method is under the jurisdiction of ASTM Committee D-14 on Adhesives and is the direct responsibility of Subcommittee D14.40 on Adhesives for Plastics

Current edition approved March 10, 1996; 2003. Published May 1996; 2003. Originally published as D 3929 – 80; approved in 1980. Last previous edition approved in 1996 as D 3929 – 93^{ε1}.

1. Scope

1.1 This test method describes a procedure for determining the compatibility of adhesives with plastics based on whether the adhesive causes cracking of stressed samples.

1.2 Specimen configurations and test fixture designs are given.

1.3 This test method is suitable for products in the form of sheet or strip. It can also be used on injection molded tensile specimens or flexural bars.

1.4 The values stated in inch-pound SI units are to be regarded as the standard. The ~~SI~~ inch-pound units given in parentheses are for information only.

1.5 *This standard does not purport to address all of the safety concerns, if any, associated with its use. It is the responsibility of the user of this standard to establish appropriate safety and health practices and determine the applicability of regulatory limitations prior to use.*

2. Referenced Documents

2.1 *ASTM Standards:*

D 638 Test Method for Tensile Properties of Plastics²

D 790 Test Methods for Flexural Properties of Unreinforced and Reinforced Plastics and Electrical Insulating Materials²

D 907 Terminology of Adhesives²

3. Terminology

3.1 *Definitions*—Many of the terms in this test method are defined in Terminology D 907.

3.2 *Definitions of Terms Specific to This Standard:*

3.2.1 *cracking, n*—a continuous localized failure of the plastic, leading to loss of structural integrity.

3.2.2 *crazing, n*—apparent fine cracks at or under the surface of a plastic.

3.2.2.1 *Discussion*—This is a form of localized yielding of the plastic due to the combined action of stress and an attacking medium. Initial crazing may be detectable only by inspection under magnification.

3.2.3 *failure, n*—an arbitrary point defined by the initial detection of cracks or crazes.

4. Summary of Test Method

4.1 This test method involves the qualitative determination of the compatibility of adhesives with plastics by observing the effect of adhesives applied in the liquid state on stressed plastic specimens. Bars of plastic are bent in a three-point loading fixture to cause a predetermined initial tensile stress on the surface of the bar. The liquid adhesive is then applied to the area of maximum stress which is checked periodically for crazing or cracking.

4.1.1 Due to the stress relaxation behavior of certain plastics, initial stress only can be determined and the stress level may decrease significantly during the course of the test.

5. Significance and Use

5.1 This test method is designed for obtaining a qualitative estimate of the compatibility of plastics and adhesives. Due to the

² Annual Book of ASTM Standards, Vol 08.01.

many process variables associated with the fabrication of plastic parts, it is not possible to use this test as a substitute for compatibility tests on actual parts.

5.2 The detection of cracks or crazes may be determined with or without optical aid. Make comparisons only among tests employing crack detection methods of equivalent sensitivity.

6. Apparatus

6.1 *Test Fixtures*— Bent beam test fixtures (see Fig. 1)³ are designed to place the specimen in three-point bending. The amount of deflection is adjustable as well as the loading span. Other fixtures may be used as long as specimen deflection is known.

6.2 The amount of deflection on the specimen is measured by use of a dial gage indicator or a vernier caliper having a depth indicator (see Fig. 2). Use a measuring device capable of reading to 0.001 in. (0.025 mm), 0.025 mm (0.001 in.).

7. Test Specimen

7.1 The preferred specimen is a flexural bar designed in accordance with Test Methods D 790.

| | |
|----------------------------------|-----------------------------|
| Depth $\frac{1}{4}$ in. (6.4 mm) | 6.4 mm ($\frac{1}{4}$ in.) |
| Depth | 6.4 mm ($\frac{1}{4}$ in.) |
| Width $\frac{1}{2}$ in. (13 mm) | 13 mm ($\frac{1}{2}$ in.) |
| Width | 13 mm ($\frac{1}{2}$ in.) |
| Length | 5 in. (130 mm) |
| Length | 130 mm (5 in.) |
| Loading Span | 4 in. (100 mm) |
| Loading Span | 100 mm (4 in.) |
| L/d | 16/1 |

Tensile bars, such as Type I in Test Method D 638, can also be used. Specimens of rectangular section may also be cut from sheets or molded plastic articles.

7.2 Mold specimens in a low-stress condition or anneal so that molded-in stresses will not have a significant effect.

7.3 Carefully cut or machine specimens in accordance with the plastic manufacturers' recommended procedures to avoid introducing stresses at machined surfaces.

8. Procedure

8.1 Place the plastic test specimen in the test fixture at the required loading (see Fig. 6).

8.2 Apply adhesive to be tested to the center point on the length of the loaded specimen. Cover a specimen length of approximately 1 in. (25 mm), 25 mm (1 in.). In general, apply the adhesive only once, as would be the case in an actual end-use application.

³ Detailed drawings are shown in Figs. 3-5. Also necessary to complete the test fixture are the following parts: 2 pieces at 6 by 38 mm ($\frac{1}{4}$ by 1½-in.) dowel pins and 2 pieces of $\frac{3}{8}$ M4-0.7 (8-32 unc) by 32 mm (1¼-in.) socket head cap screws.

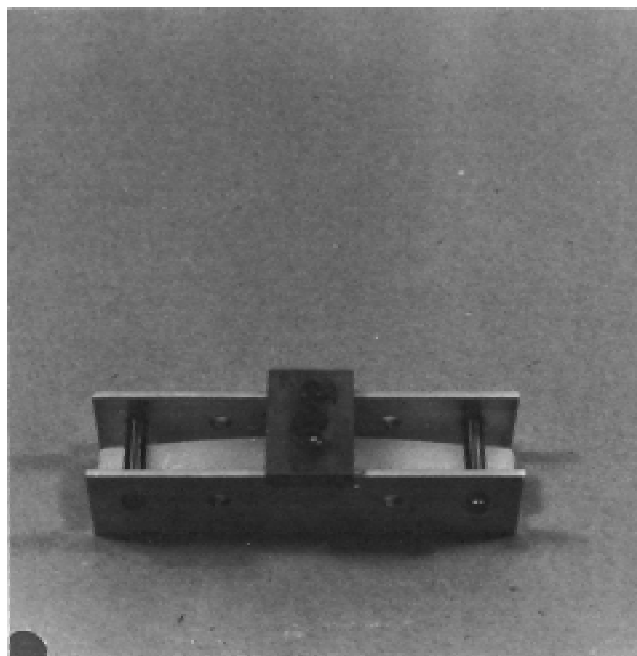

FIG. 1 Test Fixture with Plastic Bar in Place

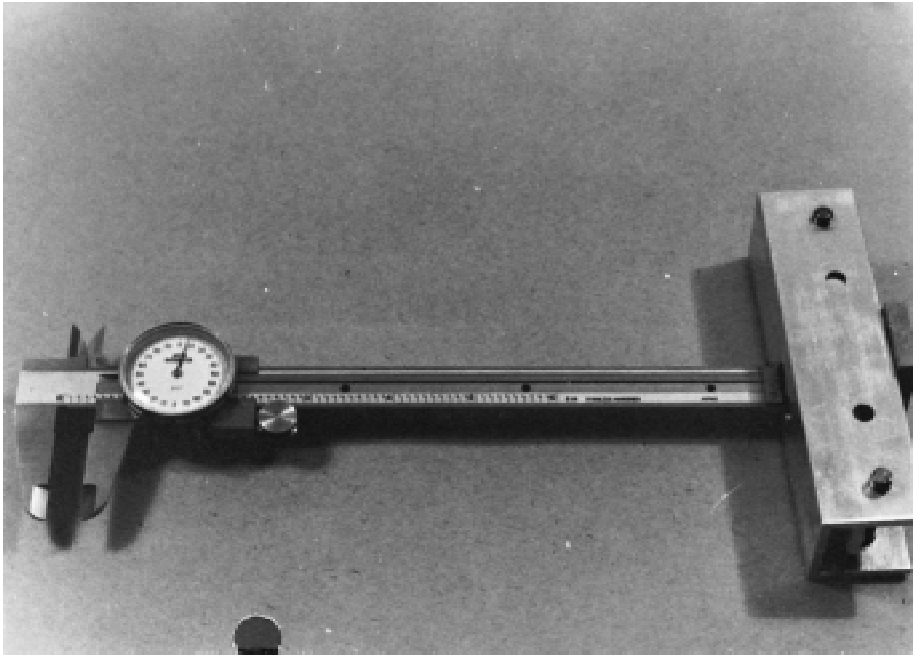

FIG. 2 Measurement of Test Bar Deflection with Depth Gauge of Vernier Caliper

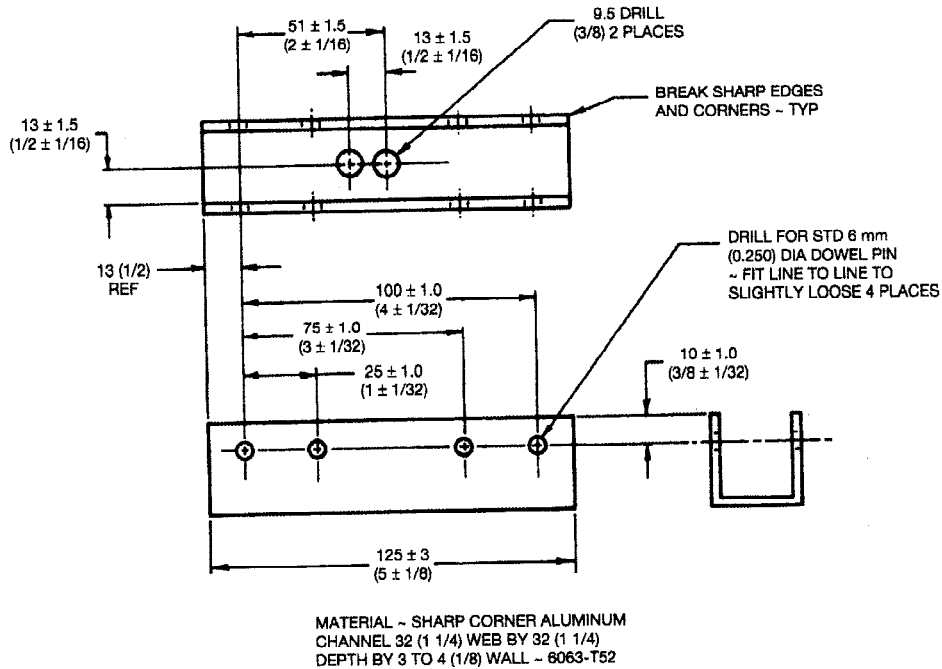

FIG. 3 Test Fixture Frame

8.2.1 If the adhesive contains a solvent, allow it to evaporate at a normal rate.

8.2.2 If the adhesive is a curing type, cure in a normal fashion.

8.2.3 If the adhesive is a hot melt, apply at the normal application temperature and then allow to cool. This is a less severe condition than would occur if the adhesive were continually applied, but is more consistent with situations that occur in actual adhesive use.

8.3 *Control Specimens*—Concurrently run one control specimen with the test specimens in the same location. Excessive molded-in stresses or airborne solvent vapors may cause stress cracking even without application of adhesive.

9. Stress Calculations

9.1 The equation given below is valid only for specimens of rectangular cross section at stresses below the elastic limit of the

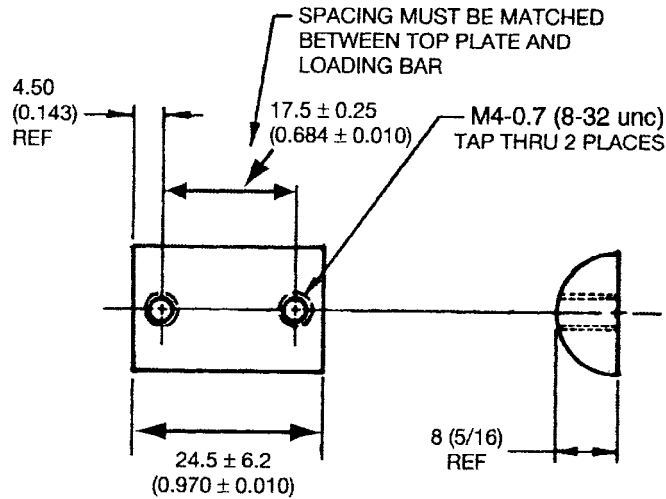

MATERIAL ~ 16 mm (5/8) HALF ROUND HOT ROLLED BAR

FIG. 4 Test Fixture Center Loading Bar

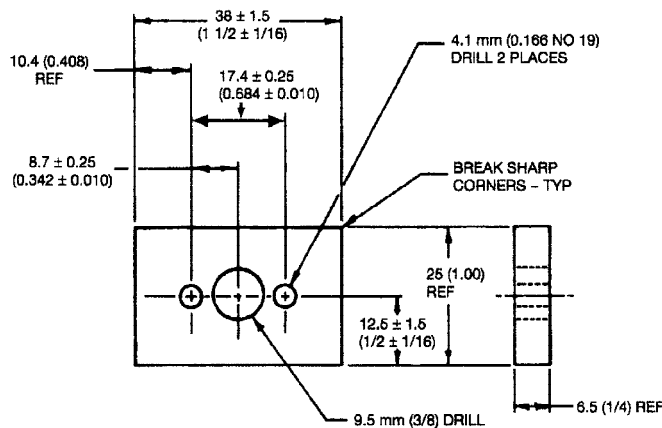

MATERIAL ~ 6.4 (1/4) BY 25 (1) COLD DRAWN FLAT

FIG. 5 Test Fixture Top Plate

material. The deflection is based on initial stress only. The level of stress will normally decrease with time as the plastic undergoes relaxation. Deflection is calculated based on the desired stress level as follows:

$$D = SL^2/6 d E \tag{1}$$

where:

- D = deflection, in. (m), m (in.),
- S = stress, psi (Pa), Pa (psi),
- L = loading span, in. (m), m (in.),
- d = specimen depth, in. (m), m (in.), and
- E = modulus of the plastic, psi (Pa), Pa (psi).

NOTE 1—This equation holds for rectangular specimens only.

9.2 If it is desired to run tests on the basis of constant strain, the following formula can be used:

$$D = \frac{rL^2}{6 d} \tag{2}$$

where r = strain, in./in. (m/m), m/m (in./in.).

9.3 Tensile stress and strain values represent the maximum level at the surface of the specimen in the area to which adhesive is applied. This is mid-span in the three-point loading arrangement.

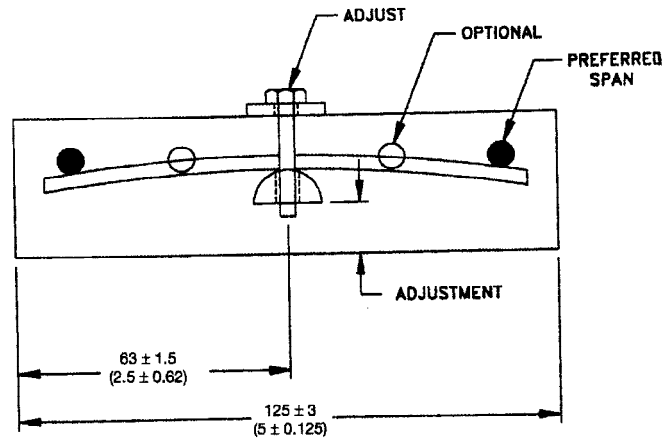

FIG. 6 Cut-Away View of Sample Mounted in Fixture

10. Choice of Test Conditions

10.1 Suggested stress levels for testing are 1000, 2000, and 3000 psi (7, 14, and 21 MPa (1000, 2000, and 3000 psi). For initial screening, 21 MPa (3000 psi) is recommended since incompatible adhesives will cause rapid crazing or cracking. Lower stress levels may be used for discerning finer differences in materials.

10.2 Testing can also be based on constant strain if this is more meaningful for particular end-use applications.

10.3 The test duration is 5 days for adhesives that harden or cure. For adhesives that remain in the liquid state on the specimens (for example, anaerobic adhesives), the test should be extended to 10 days.

10.4 Maintain environmental conditioning at $23 \pm 2^\circ\text{C}$ ($73 \pm 3.5^\circ\text{F}$), $50 \pm 5\%$ RH. Specify other conditions as agreed to by user and manufacturer.

10.5 Since stress cracking is more likely to occur immediately after application of the adhesive, it is desirable to observe the specimens at frequent intervals in the beginning of the test. A suggested observation schedule is as follows: 1 min, 5 min, 1 h, 24 h, and daily thereafter.

11. Inspection of Specimens

11.1 Determine the presence of cracks or crazes by careful visual observation.

NOTE 2—Magnification may be used upon agreement by user and manufacturer.

11.2 If adhesives are not transparent, remove sufficient adhesive to determine if cracks or crazes are present.

12. Report

12.1 Report the results of the test as the absence or presence of cracks or crazes at a given stress level. If cracks or crazes are present, the time required for their occurrence is also reported. Report the following specific items:

12.1.1 Specimen identification,

12.1.2 Material name or specification code,

12.1.3 Adhesive identification,

12.1.4 Stress level,

12.1.5 Type and orientation of specimen used and method of fabrication (injection molded, tensile specimen, annealed, etc.),

12.1.6 Detailed description of test environment (for example, temperature, humidity, exposure time), and

12.1.7 Remarks concerning the size and appearance of cracks or crazes may be included if significant.

NOTE 3—Indicate magnification techniques used for inspection, if any.

13. Precision and Bias

13.1 No information is presented about either the precision or bias of Test Method D 3929 for evaluating stress cracking of plastics by adhesives since the test result is ~~nonquantitative~~ nonquantitative.

14. Keywords

14.1 adhesive compatibility; bent-beam; cracking; crazing; liquid adhesive; stress cracking

 **D 3929 – 03**

ASTM International takes no position respecting the validity of any patent rights asserted in connection with any item mentioned in this standard. Users of this standard are expressly advised that determination of the validity of any such patent rights, and the risk of infringement of such rights, are entirely their own responsibility.

This standard is subject to revision at any time by the responsible technical committee and must be reviewed every five years and if not revised, either reapproved or withdrawn. Your comments are invited either for revision of this standard or for additional standards and should be addressed to ASTM International Headquarters. Your comments will receive careful consideration at a meeting of the responsible technical committee, which you may attend. If you feel that your comments have not received a fair hearing you should make your views known to the ASTM Committee on Standards, at the address shown below.

This standard is copyrighted by ASTM International, 100 Barr Harbor Drive, PO Box C700, West Conshohocken, PA 19428-2959, United States. Individual reprints (single or multiple copies) of this standard may be obtained by contacting ASTM at the above address or at 610-832-9585 (phone), 610-832-9555 (fax), or service@astm.org (e-mail); or through the ASTM website (www.astm.org).