



Standard Test Method for Heat and Moisture Resistance of Wood-Adhesive Joints¹

This standard is issued under the fixed designation D 4502; the number immediately following the designation indicates the year of original adoption or, in the case of revision, the year of last revision. A number in parentheses indicates the year of last reapproval. A superscript epsilon (ϵ) indicates an editorial change since the last revision or reapproval.

1. Scope

1.1 The purpose of this test method is to estimate the resistance of adhesive-bonded joints to thermal and hydrolytic degradation.

1.2 This test method is primarily for wood-to-wood joints but may be applied to joints of wood to other materials.

1.3 The effects of chemicals such as fire retardants, preservatives, and extractives in the wood upon joint degradation resistance can be estimated.

1.4 This test method does not account for the effects of stress, the other principal degrading factor, nor does it account for cyclic or variable temperature or moisture levels.

1.5 *This standard does not purport to address all of the safety concerns, if any, associated with its use. It is the responsibility of the user of this standard to establish appropriate safety and health practices and determine the applicability of regulatory limitations prior to use.*

2. Referenced Documents

2.1 ASTM Standards:²

D 897 Test Method for Tensile Properties of Adhesive Bonds

D 905 Test Method for Strength Properties of Adhesive Bonds in Shear by Compression Loading

D 907 Terminology of Adhesives

D 2304 Test Method for Thermal Endurance of Rigid Electrical Insulating Materials

D 2307 Test Method for Relative Thermal Endurance of Film-Insulated Round Magnet Wire

D 2339 Test Method for Strength Properties of Adhesives in Two-Ply Wood Construction in Shear by Tension Loading

2.2 IEEE Standard:

IEEE No. 1, General Principles for Temperature Limits in the Rating of Electrical Equipment³

3. Terminology

3.1 Definitions

3.1.1 For definitions of terms used in this test method, refer to Terminology D 907.

3.2 *shear strength, n*—in an adhesive joint, the maximum average stress when a force is applied parallel to the joint.

3.2.1 *Discussion*—In most adhesive test methods, the shear strength is actually the maximum average stress at failure of the specimen, not necessarily the true maximum stress in the material.

4. Summary of Test Method

4.1 The degradation of adhesive joints is a physicochemical process. The speed of degradation is related to the levels of temperature, moisture (and other chemicals), and physical stress to which the joint is exposed. This test method is based on the principles of chemical kinetics and uses the Arrhenius temperature dependence relationship to estimate the long-term effects of heat and moisture at the service temperature.

4.2 Specimens whose unaged properties have been estimated by control tests are subjected to an accelerated thermal or hydrolytic aging environment in groups. Aging is accelerated by using elevated temperature. Periodically, a group of specimens is removed from the aging environment and tested. The estimated property after aging and the time of aging are recorded. After several groups have been tested in this manner, the rate of property loss in the aging environment can be estimated. This basic experiment is repeated at several other elevated temperatures, and the rates of property loss at those temperatures estimated. The rate of property loss relationship to temperature is estimated. This relationship can be extrapolated to lower service temperatures for estimating service life.

4.3 This test method employs a smaller version of the Test Method D 905 block shear specimen, but other shear strength or tensile strength specimens may also be used.

¹ This test method is under the jurisdiction of ASTM Committee D14 on Adhesives and is the direct responsibility of Subcommittee D14.70 on Construction Adhesives.

Current edition approved April 1, 2004. Published April 2004. Originally approved in 1985. Last previous edition approved in 1992 as D 4502 – 92 (1998)¹.

² For referenced ASTM standards, visit the ASTM website, www.astm.org, or contact ASTM Customer Service at service@astm.org. For *Annual Book of ASTM Standards* volume information, refer to the standard's Document Summary page on the ASTM website.

³ Available from Institute of Electrical and Electronics Engineers, Inc. (IEEE), 445 Hoes Ln., P.O. Box 1331, Piscataway, NJ 08854-1331

5. Significance and Use

5.1 This test method can serve as a useful tool for durability assessment and service life forecasting.

5.1.1 This test method can be used to measure the effects of heat and moisture and the effect of their interaction on adhesives and bonded joints. Knowledge of these effects is useful to an adhesive formulator or manufacturer. Moist heat aging is particularly useful for determining the effects of acidic adhesive systems on the hydrolysis of wood adherends.

5.1.2 This test method provides a means of comparing the rate of degradation of an unknown adhesive-adherend combination to the rate of degradation of a known combination in thermal or hydrolytic aging environments. Such a comparison can be useful to adhesive manufacturers for introducing a new product to the market and for helping designers selecting adhesives.

5.1.3 This test method does not duplicate any natural service environment, but it does provide a means of estimating the service life of joints in similar environments. Service-life estimates are useful to designers of bonded structures or structures using bonded products.

5.2 Service-life estimates rely on the assumption that the chemical degradation mechanism is the same at the elevated aging temperatures as at the service temperature. However, this may not be true in every case. This possibility, together with the variability in specimen preparation, in the aging exposures, and in the strength measurements, require that caution be used in accepting the estimate of service life.

6. Apparatus

6.1 *Aging Ovens*—Ovens are required that are capable of control within $\pm 2\%$ of specified exposure temperature throughout the chamber for extended periods of time ($\pm 0.5^\circ\text{C}$ control is desirable).⁴ The ovens must be capable of operating at temperatures from 60 to 175°C. The oven must have an internal capacity for up to 100 specimens well-spaced and supported on racks to allow free air flow.

6.2 *Environmental Chambers*—Chambers for moist-heat aging must be capable of $\pm 0.5^\circ\text{C}$ temperature and 0.5 % relative humidity control uniformly throughout the chamber. The chamber must be capable of operating at temperatures from 60 to 90°C and relative humidity from 60 to 80 %. The chamber must have the capacity for up to 100 specimens well-spaced and supported on racks to allow free air flow.

6.3 *Moist Aging Jars*—Heat-resistant glass jars are required to expose specimens to constant relative humidity and temperature over saturated salt solutions. Wide-neck canning jars with volumes of 3½ L (1 gal), rubber gaskets, and clamp lids have proven satisfactory at temperatures of 100°C (212°F) and below. The jars must have a platform inside (without legs) to support specimens above the saturated salt solution. A 6-mm (¼-in.) diameter bead of silicone sealant around the inside surface of the jar and about 5 cm (2 in.) above the bottom provides a ledge to support the platform. The platform must be

perforated to permit free-flow of water vapor. It may be cut from any material that is resistant to corrosion, heat, and moisture. Perforated high-density hardboard has proven satisfactory. The platform must be cut in half to pass through the neck of the jar. An aging jar with platform is shown in Fig. 1. The jars must be placed in an aging oven, such as described in 5.1, to achieve the required temperature.

6.4 *Water Baths*—Constant-level water baths capable of control to within 0.5°C of the desired temperature are required. The baths must be able to contain 100 specimens.

6.5 *Testing Machine*—The testing machine shall have a capacity of not less than 3000 kg (6210 lbf) in compression. The machine shall be capable of maintaining a uniform rate of loading such that the load may be applied with a continuous motion of the movable head to the maximum load at a rate of 10.0 ± 5 mm/min (0.40 in./min) with a permissible variation of $\pm 0.5\%$.

6.6 *Shearing Tool*—A shearing tool similar to the tool pictured in Test Method D 905 is satisfactory. The tool must have a self-aligning seat to ensure uniform lateral distribution of the load.

7. Materials

7.1 *Adhesive to Be Tested:*

7.2 *Joints*—Wood for wood-to-wood joints or joints of wood to metal or plastic shall be free of defects such as knots, cracks, short-grain and sharp-grain deviations, or any discolorations or soft spots indicative of decay. Generally, a high-density uniform-textured wood is desirable so that the maximum stress will be placed on the adhesive joint during testing. The standard shall be hard maple (*Acer saccharum* or *Acer nigrum*) having a minimum specific gravity of 0.65 (based on oven-dry weight and volume). Other species may be used where evaluation of the adhesive's performance in contact with that species is a specific requirement.

7.3 *Saturated Salt Solutions*—A constant relative humidity at a given temperature can be maintained in sealed aging jars by a saturated aqueous solution in contact with an excess of the solid phase of a specific salt. Tables are available that show relative humidities at given temperatures for many salts.⁵ Sodium chloride is recommended. A saturated solution of sodium chloride will produce a relative humidity of 73 to 76 % over the temperature range from 40 to 100°C. This translates to wood moisture content in the approximate range from 9 to 13 %.

8. Test Specimens

8.1 A modified block shear specimen (Fig. 2) is suggested. The specimen is similar to the specimen of Test Method D 905, but its smaller size allows more specimens to fit in the aging chambers. Other specimens such as used in Test Method D 897 or Test Method D 2339 are also satisfactory. If a type from Test Method D 2339 is selected, then use 6.5-mm (¼-in.) lumber for each lamina, and increase the specimen length to 130 mm (5.1 in.) while maintaining the 25.4-mm (1-in.) overlap. Other

⁴ Millett, M. A., Western, L. J., and Booth, J. J., "Accelerated Aging of Cellulosic Materials: Design and Application of a Heating Chamber," TAPPI, Vol 50, No. 11, 1967, pp 74A–80A.

⁵ Dean, J. A., ed., *Lange's Handbook of Chemistry*, 12th ed., McGraw-Hill Book Co., Inc., 1978.

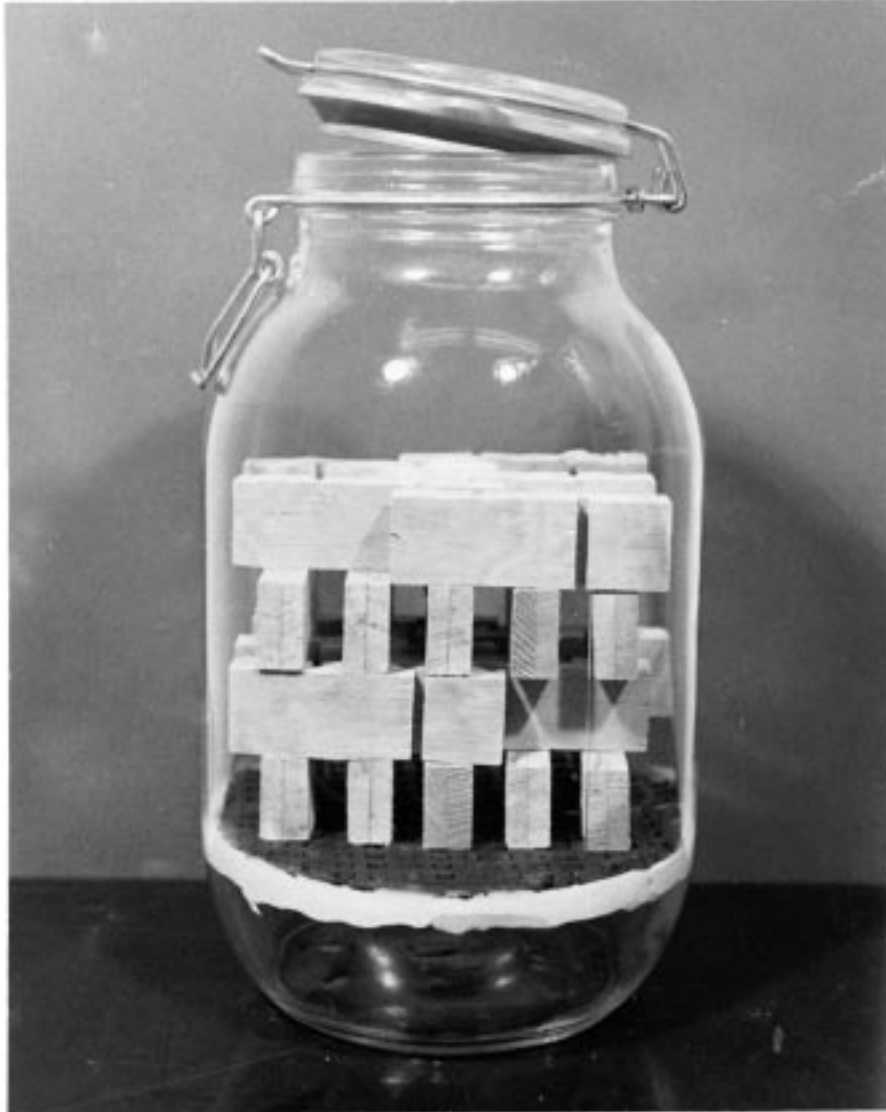

FIG. 1 Moist Aging Jar with a Shelf for Aging Specimens Over a Saturated Salt Solution

bonded joints or products may also be tested if a suitable specimen can be devised.

8.2 Condition the wood at $23 \pm 2^\circ\text{C}$ ($73.4 + 3.6^\circ\text{F}$) and relative humidity of either 30 or 65 %, or other conditions, depending on the adhesive manufacturer's requirement.

8.3 Prepare modified shear block specimens as described in Test Method D 905 with the following exceptions:

8.3.1 Cut rough 25.4-mm (1-in.) lumber into 127 or 63 by 305-mm (5 or 2½ by 12-in.) billets as required by Section 9. Saw each billet in half through the thickness using a bandsaw. Joint the surface of each half that is to be bonded and plane to 8-mm ($\frac{5}{16}$ -in.) thickness. (Note 1) Bond the billets as described in Test Method D 905.

NOTE 1—If during strength testing specimens fail in compression parallel to the grain at the ends, the laminae thickness should be increased from 8 mm ($\frac{5}{16}$ in.) to 9.5 mm ($\frac{3}{8}$ in.) or greater, as necessary.

8.3.2 After bonding, trim one edge and one end of each panel. Then cut two rows of five specimens each from the 63 by 305-mm (2½ by 12-in.) panels, as shown in Fig. 3, or four rows of five specimens each from the 127 by 305-mm (5 by 12-in.) panels.

NOTE 2—The adhesive should be thoroughly cured by hot pressing, oven heating, high-frequency heating, or whatever method is appropriate. Undercured adhesives cause unwanted results in the early stages of elevated temperature aging.

8.4 Mark each specimen using a templet before cutting to indicate the panel and position in the panel.

9. Sampling

9.1 Sample Size:

9.1.1 If using the modified block shear specimen, prepare the following numbers and sizes of panels, depending on the

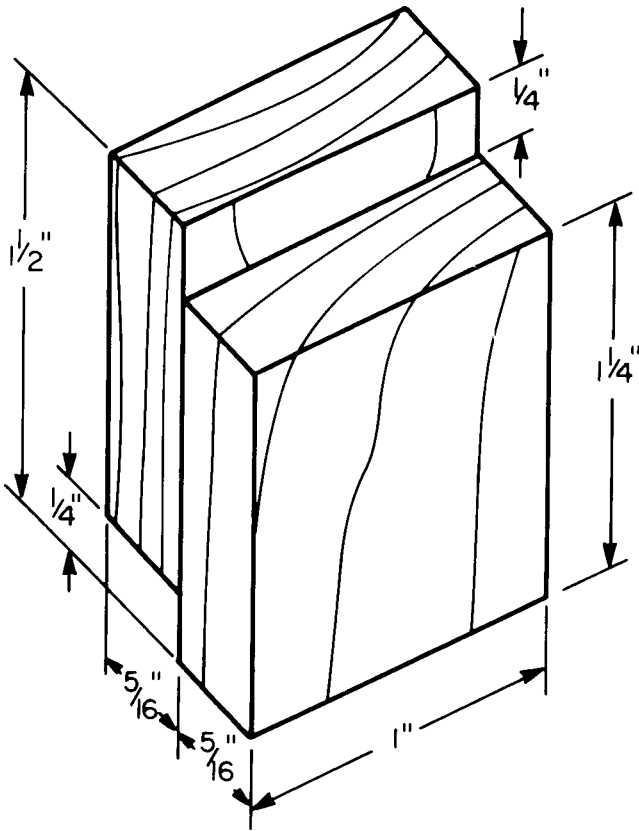

FIG. 2 Modified Block Shear Specimen

9.2.3 The distribution of specimens for subsequent data analysis is summarized by the block experimental designs shown in Table 4 for each of the experiments.

10. Procedure

10.1 Initial Strength:

10.1.1 Condition the control specimens to equilibrium moisture content (EMC) at 23 + 2°C and 50 ± 2 % relative humidity or other conditions as agreed upon by the parties involved. One to four weeks may be required to reach EMC, depending on the beginning moisture content.

10.1.2 Test the specimens (after they reach EMC) in the shear tool with the universal test machine crosshead moving at 10 + 0.05 mm/min (0.400 ± 0.002 in./min). Store the specimens in a plastic bag, or remove them one at a time from the conditioned environment during testing. Record the strength and estimated percentage of wood failure for each specimen.

10.2 Service Life Estimate:

10.2.1 Aging temperatures are given in Table 4. For a given temperature/moisture condition, mount five groups (10 specimens per group) on suitable racks for dry aging, place in jars for moist aging, or string each group on stainless steel wire for wet aging.

10.2.2 Estimate five aging intervals that will produce approximately equal strength decrements to a total strength loss of 25 to 30 % from the initial strength for each of the five aging temperatures. Previous aging experience may not be available, especially for new adhesives. If this is the case, use the approximate times given in Table 5.

NOTE 3—Twenty-five percent strength loss is a convenient level. Any amount of loss can be defined as failure as long as it is agreeable to the parties requiring this test and it is defined in the report. Higher percentages of loss require longer exposure times.

10.2.3 Place the five groups (see Note 4) in the aging exposure. At the end of the first aging interval, withdraw the first group of specimens, recondition to EMC, and test as described in 10.1.1 and 10.1.2. Based on this test, project the time to reach 25 % loss. If necessary, adjust the remaining intervals to provide approximately equal strength decrements to the 25 to 30 % strength loss (from the initial value). Repeat this projection and adjustment after each of the first four aging intervals.

NOTE 4—When the aging intervals are shorter than the time necessary to recondition the aged specimens to EMC at 23°C and 50 % relative humidity before testing, then all five groups should not be placed in the aging exposure at once. Instead, place only one or two groups on exposure. In this way specimens will still be available for shorter aging intervals in case the strength degraded too far in the first interval.

10.3 Degradation Rate Comparison:

10.3.1 Aging may be dry, moist, or wet depending on the aging conditions of the adhesive to which the test adhesive is to be compared. Select three temperatures from Table 1 for the chosen moisture level. If the adhesive is thought to be very durable, use the three highest temperatures. If the adhesive is thought to be less durable, use the three lower temperatures. For a given temperature, use five groups (20 specimens per group). Prepare for aging as described in 9.2.1.

type of experiment to be performed (service life, rate comparison, or quality control):

- Service life estimation 10 panels, 127 by 305 mm
- Rate comparison:
 - One adhesive/different exposures (10 panels, 127 by 305 mm)
 - Two adhesives/same exposure (10 panels, 63 by 305 mm) (for each adhesive)
- Quality control (10 panels, 63 by 305 mm)

9.1.2 If using some other specimen, prepare 10 panels, each panel large enough to yield the following minimum number of specimens depending on the type of experiments to be performed:

Service life	26
Rate comparison:	
One adhesive/different exposure	22
Two adhesives/same exposure	12
Quality control	3

9.2 Sampling Method:

9.2.1 In a given experiment (service life, rate comparison, or quality control) pair the 6.5 by 127 (or 63) by 305-mm billets randomly for bonding into panels.

9.2.2 Distribute the specimens from each panel according to the plan shown in the appropriate table for the experiment.

Service-life estimation	Table 1
Rate comparison	Table 2
Quality control	Table 3

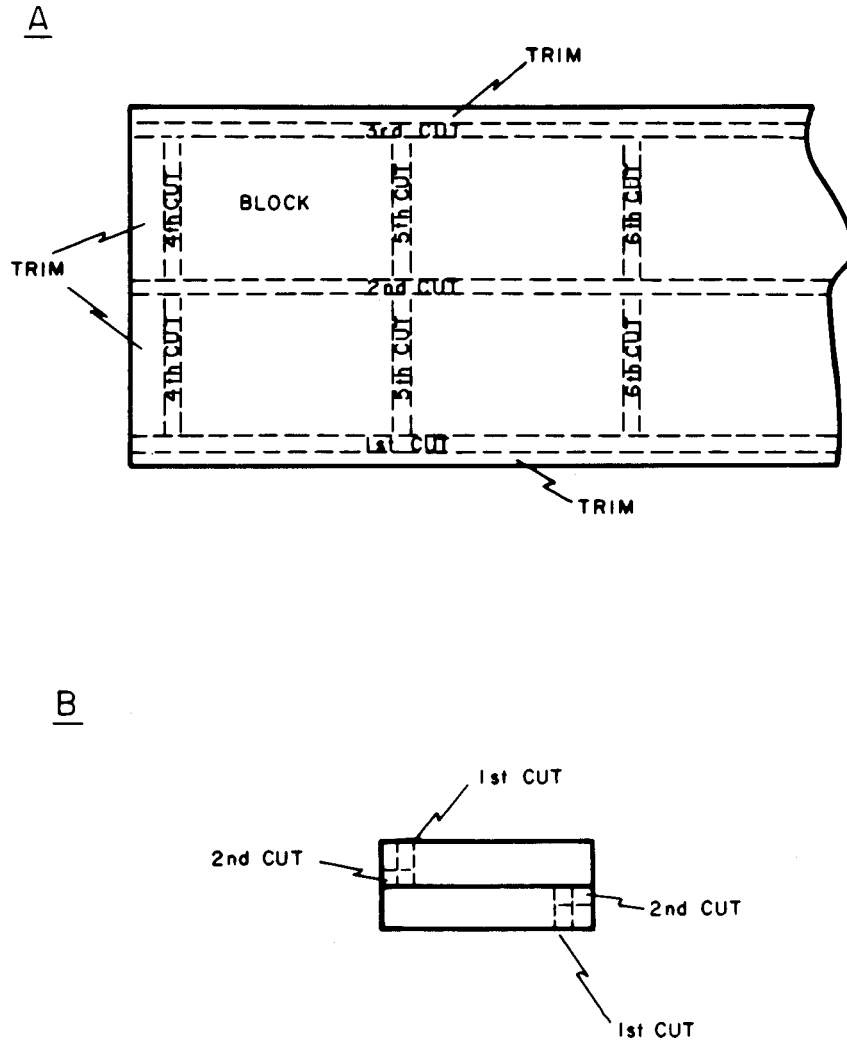

FIG. 3 (A) Top View of One End of a Panel Showing Trim and Individual Blocks for Specimens, and (B) Side View Showing Two Cuts on Each End of a Block to Form the Offset

10.3.2 Estimate five aging intervals to 25 to 30 % strength loss as described in 10.2.2, 10.2.3, and Note 4.

10.3.3 After aging, recondition the specimens to EMC and test as described in 10.1.1 and 10.1.2.

10.4 *Quality Control:*

10.4.1 Normally the quality control test will be applied to adhesives previously evaluated by the service life or degradation rate procedures. Select one temperature for dry and one temperature for wet aging from Table 4 that should cause a 25 to 30 % strength loss in less than 48 h, based on the previous aging experience. If previous experience is not available, select a temperature/time from Table 5 as a starting point.

10.4.2 Age the group of specimens for a time that is the same as one of the times used in the previous evaluation and that should cause about 25 to 30 % strength loss. After aging, recondition to EMC and test in accordance with 10.1.1 and 10.1.2.

11. **Calculations**

11.1 *Service Life Estimate:*

11.1.1 Make a visual estimate of the expected service life as follows:

11.1.1.1 Calculate the average values of the residual shear strength from the 10 specimens at each aging interval, for each temperature.

11.1.1.2 Prepare rate curves for each temperature by plotting the log of the average residual strength at a given aging interval as a function of the aging time.

11.1.1.3 Determine the estimate of the initial strength (y axis intercept) and the aging time at which each rate curve intersects the 75 % residual strength line (Fig. 4).

11.1.1.4 For the wet and dry aging conditions, plot the aging times to 75 % residual strength as a function of temperature in the Arrhenius convention of log time versus reciprocal temperature (Fig. 5). Visually fit a straight line through the five temperature data points for the wet or dry condition.

11.1.1.5 Project this line to the temperature at which the expected service life is to be estimated but not more than 50°C lower than the lowest accelerated aging temperature.

TABLE 1 Specimen Distribution for Service Life Estimation Experiment at a Single Moisture Level Using Ten 127 by 305-mm (5 by 12-in.) Bonded Panels Yielding 2 Specimens Each

Test group		Panel										Total
Temperature	Aging interval	1	2	3	4	5	6	7	8	9	10	
Control		1	1	1	1	1	1	1	1	1	1	10
1	1	1	1	1	1	1	1	1	1	1	1	10
1	3	1	1	1	1	1	1	1	1	1	1	10
1	4	1	1	1	1	1	1	1	1	1	1	10
1	5	1	1	1	1	1	1	1	1	1	1	10
2	1	1	1	1	1	1	1	1	1	1	1	10
2	2	1	1	1	1	1	1	1	1	1	1	10
2	3	1	1	1	1	1	1	1	1	1	1	10
2	4	1	1	1	1	1	1	1	1	1	1	10
2	5	1	1	1	1	1	1	1	1	1	1	10
3	1	1	1	1	1	1	1	1	1	1	1	10
3	2	1	1	1	1	1	1	1	1	1	1	10
3	3	1	1	1	1	1	1	1	1	1	1	10
3	4	1	1	1	1	1	1	1	1	1	1	10
3	5	1	1	1	1	1	1	1	1	1	1	10
4	1	1	1	1	1	1	1	1	1	1	1	10
4	2	1	1	1	1	1	1	1	1	1	1	10
4	3	1	1	1	1	1	1	1	1	1	1	10
4	4	1	1	1	1	1	1	1	1	1	1	10
4	5	1	1	1	1	1	1	1	1	1	1	10
5	1	1	1	1	1	1	1	1	1	1	1	10
5	2	1	1	1	1	1	1	1	1	1	1	10
5	3	1	1	1	1	1	1	1	1	1	1	10
5	4	1	1	1	1	1	1	1	1	1	1	10
5	5	1	1	1	1	1	1	1	1	1	1	10
Total		26	26	26	26	26	26	26	26	26	26	260
Leftover		2	2	2	2	2	2	2	2	2	2	20

TABLE 2 Specimen Distribution for the Experiment to Compare Degradation Rates of a Single Adhesive^A in Two Exposures Using 127 by 305-mm (5 by 12-in.) Bonded Panels Yielding 28 Specimens Each

Test Group	Aging Interval	Panel										Total
		1	2	3	4	5	6	7	8	9	10	
		Exposure I										
Control		2	2	2	2	2	2	2	2	2	2	20
	1	2	2	2	2	2	2	2	2	2	2	20
	2	2	2	2	2	2	2	2	2	2	2	20
	3	2	2	2	2	2	2	2	2	2	2	20
	4	2	2	2	2	2	2	2	2	2	2	20
	5	2	2	2	2	2	2	2	2	2	2	20
		Exposure II										
Control		2	2	2	2	2	2	2	2	2	2	20
	1	2	2	2	2	2	2	2	2	2	2	20
	2	2	2	2	2	2	2	2	2	2	2	20
	3	2	2	2	2	2	2	2	2	2	2	20
	4	2	2	2	2	2	2	2	2	2	2	20
	5	2	2	2	2	2	2	2	2	2	2	20
Total		24	24	24	24	24	24	24	24	24	24	240
Leftover		4	4	4	4	4	4	4	4	4	4	40

^ATo compare two different adhesives in a single exposure prepare ten 63 by 305-mm (2½ by 12-in.) panels (yielding 14 specimens each) with each adhesive. If comparing two adhesives, a group of control specimens is also required for the second adhesive.

11.1.2 Make a statistical estimate of the service life in a given moisture condition. Detailed procedures are given in Annex A2 or Annex A3 (Version I or II).

11.1.2.1 First, for data at the moisture condition, fit the strength-aging time data obtained at each aging temperature to the following equation:

$$\log_{10}y = \log_{10}a + kt \quad (1)$$

TABLE 3 Specimen Distribution for Wet and Dry Quality Control Tests Using Ten 63 by 305-mm (2½ by 12-in.) Bonded Panels Yielding 14 Specimens Each

Test group	Panel										Total	
	1	2	3	4	5	6	7	8	9	10		
Dry control	2	2	2	2	2	2	2	2	2	2	2	20
Dry exposure	2	2	2	2	2	2	2	2	2	2	2	20
Wet control	2	2	2	2	2	2	2	2	2	2	2	20
Wet exposure	2	2	2	2	2	2	2	2	2	2	2	20
Total	8	8	8	8	8	8	8	8	8	8	8	80
Leftover	6	6	6	6	6	6	6	6	6	6	6	60

TABLE 4 Block Experimental Designs for Service Life Estimation, Rate Comparison, and Quality Control Experiments

Test Group	Aging Temperature	Aging Interval					Control
		1	2	3	4	5	
Service Life Estimation ^A							
Control	1	10	10	10	10	10	10
Dry	2	10	10	10	10	10	10
	3	10	10	10	10	10	10
	4	10	10	10	10	10	10
	5	10	10	10	10	10	10
Wet	1	10	10	10	10	10	10
	2	10	10	10	10	10	10
	3	10	10	10	10	10	10
	4	10	10	10	10	10	10
	5	10	10	10	10	10	10
Rate Comparison ^B							
Control							20
Exposure I		20	20	20	20	20	20 ^C
Control							20 ^C
Exposure II or different adhesive in the same exposure		20	20	20	20	20	
Quality Control ^D							
Dry control							20
Dry exposure		20					
Wet control							20
Wet exposure		20					

^AEach block in the table includes 1 specimen from each of 10 panels (see Table 1).
^BEach block in the table includes 2 specimens from each of 10 panels (see Table 2).
^CThis set of control specimens is required only if comparing 2 different adhesives.
^DEach block in the table includes 2 specimens from each of 10 panels (see Table 3).

TABLE 5 Aging Temperatures and Approximate^A Time Required for 25 % Strength Loss in Solid Wood and Adhesive-bonded Joints

Condition	Temperature, °C	Solid Wood/Durable Adhesive, days	Less Durable Adhesive, days
Wet	60	146	5.3
	70	50	1.25
	77.5	21.6	0.42
	85	10.8	0.17
	100	2.3	0.10
Dry	120	130	58
	130	55	17
	145	10.3	3.4
	160	2.4	0.85
	170	0.85	0.33

^AThe times are only guidelines intended to be used as a starting point for durable adhesives. They may change with species or the adhesive.

where:

- y = strength,
- t = aging time,
- a = estimated initial strength, and
- k = degradation rate constant.

11.1.2.2 Next, use the fitted strength versus aging time equations to determine the time required for the adhesive (specimen) to degrade to 75 % residual strength (75 % of the estimated initial strength) ($t_{0.75}$) at each aging temperature.

NOTE 5—The choice of 25 % strength loss as the criteria for failure is convenient but arbitrary. Any percentage may be chosen based on the consent of those parties involved.

11.1.2.3 Finally, fit the estimated failure time versus temperature data to the following equation:

$$\log_{10}y = A + B/T \quad (2)$$

where:

- y = estimated failure time ($t_{0.75}$),
- T = absolute aging temperature in degrees Kelvin ($^{\circ}\text{C} + 273$),
- A = fitted regression constant, and
- B = fitted regression coefficient (temperature dependence).

11.1.2.4 Finally, calculate the estimated mean failure time at service temperature ($SL_{0.75}$) and the lower confidence limit for individual estimates of service life.

11.2 Rate Comparison:

11.2.1 This procedure may be used to compare two adhesives aged at the same temperature/moisture condition or one adhesive at two different temperature levels (one moisture level) or two moisture levels (one temperature level).

11.2.2 Fit the strength versus time data for each adhesive or condition to be compared to the linear regression equation. Use the same equation and procedure as for the first portion of the service life estimation.

11.2.3 Test the two fitted equations for differences in their slope or level in accordance with the procedure outlined in Annex A2 or Annex A3.

11.3 Quality Control:

11.3.1 The quality control test requires that the adhesive has previously been tested at the same temperature/moisture level and the same aging time. These are the baseline tests.

11.3.2 For the baseline tests and the current tests, calculate the mean initial strengths and the mean strengths after dry and wet aging. Determine the differences between the corresponding baseline and current test means.

11.3.3 Calculate the corrected sums of squares for every set of data as follows:

$$SS = \Sigma X^2 - \left(\frac{(\Sigma X)^2}{n} \right) \quad (3)$$

where:

- SS = sums of squares,
- X = individual specimen strength, and
- n = number of specimens in the data set (normally 20 in this test method).

11.3.4 Calculate the pooled within-group variance for corresponding sets of specimens, for example, baseline and current initial strength as follows:

$$s^2 = \frac{SS_{\text{baseline}} + SS_{\text{current}}}{(n_{\text{baseline}} - 1) + (n_{\text{current}} - 1)} \quad (4)$$

11.3.5 Calculate the “t” statistic for the corresponding sets of specimens as follows:

$$t_{\text{calc}} = \frac{\text{Difference between means}}{\sqrt{\frac{s^2(n_{\text{baseline}} + n_{\text{current}})}{(n_{\text{baseline}})(n_{\text{current}})}} \quad (5)$$

11.3.6 Compare the calculated t value with the expected value of t (two-sided test) ($n_{\text{baseline}} - 1$) + ($n_{\text{current}} - 1$) degrees of freedom (df) and 95 % probability. The expected value of t (for a two-sided test) may be found in tabular form in most basic statistics textbooks.

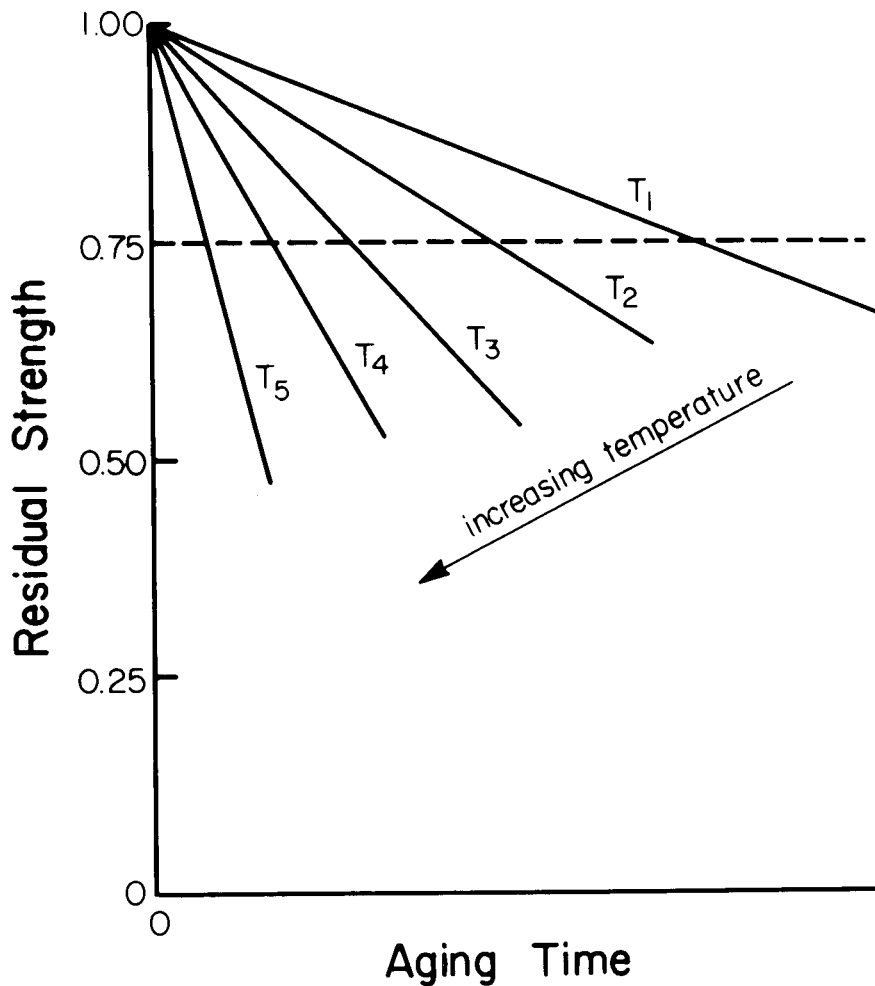

FIG. 4 Schematic Representation of Ideal Residual Strength Versus Aging Time at Five Temperatures

11.3.6.1 If $t_{calc} < t_{exp}$, the strengths of the corresponding tests are not significantly different at the 95 % level of confidence.

11.3.6.2 If $t_{calc} > t_{exp}$, the strengths of the corresponding tests are significantly different at the 95 % level of confidence.

12. Interpretation of Results

12.1 Four factors may confuse a rate process analysis, three pertaining to the strength-time relationship and one pertaining to the time-temperature relationship. They are illustrated in Fig. 6 and described in the following paragraphs.

12.2 Joint strength may increase or decrease rapidly upon the first exposure to elevated temperature (Fig. 6a). This response may be due to driving off lingering solvents, chemical crosslinking, chemical degradation, internal stress relief, or some other short-term response to a temperature rise.

12.3 The long-term degradation rate may change during the aging period (Fig. 6b). Both the wood and the adhesive degrade in the aging exposure, most likely at different rates. If the wood is initially stronger, as is usually the case with mastic adhesive joints, the rate of change in joint strength reflects the degradation rate of the adhesive. But as sometimes happens, the wood may be degrading faster than the adhesive and eventually become less strong than the adhesive. Then the rate of change in joint strength reflects the wood degradation rate.

12.4 Statistical variability creates unusual and confusing patterns of strength versus time (Fig. 6c). The strength test is, of course, destructive. The strength of one or a group of specimens cannot be followed sequentially through the entire aging exposure. Instead, separate groups of specimens must be exposed and tested at several different aging times. This introduces variability that can be confused with one of the previous factors.

12.5 The aging mechanism may change with temperature (Fig. 6d). Just as the visible degradation rate may change with time, the visible degradation mechanism may change with temperature. Thus the temperature dependence of strength loss may be different at the elevated accelerated lower service temperature. Extrapolation of the shear strength bond-life relationship from the aging temperatures to the service temperature would be misleading. This error can be minimized by checking the linearity of the service life-temperature relationship using a statistical test, and by restricting the extrapolation to not more than 50°C from the lowest accelerated aging temperature.

13. Report

- 13.1 The report shall include the following information:
- 13.2 Description of the adhesive and the adherends.
- 13.3 Date of bonding.

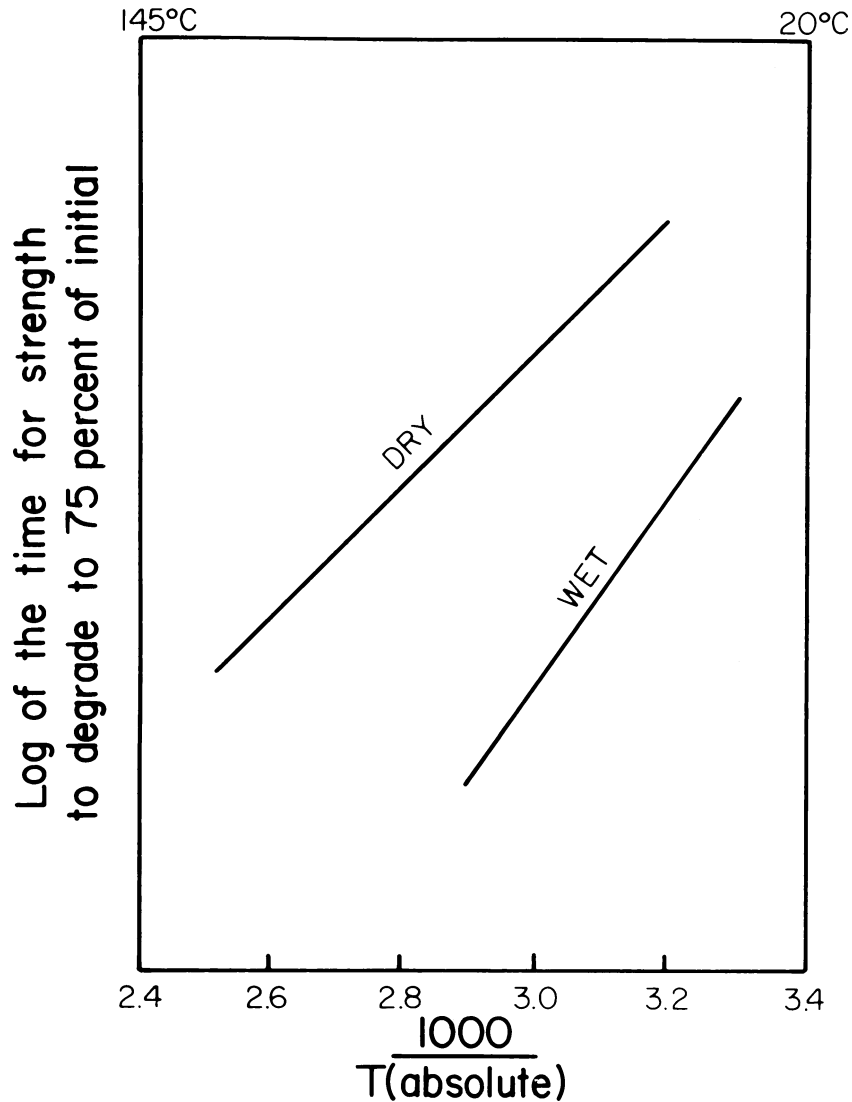
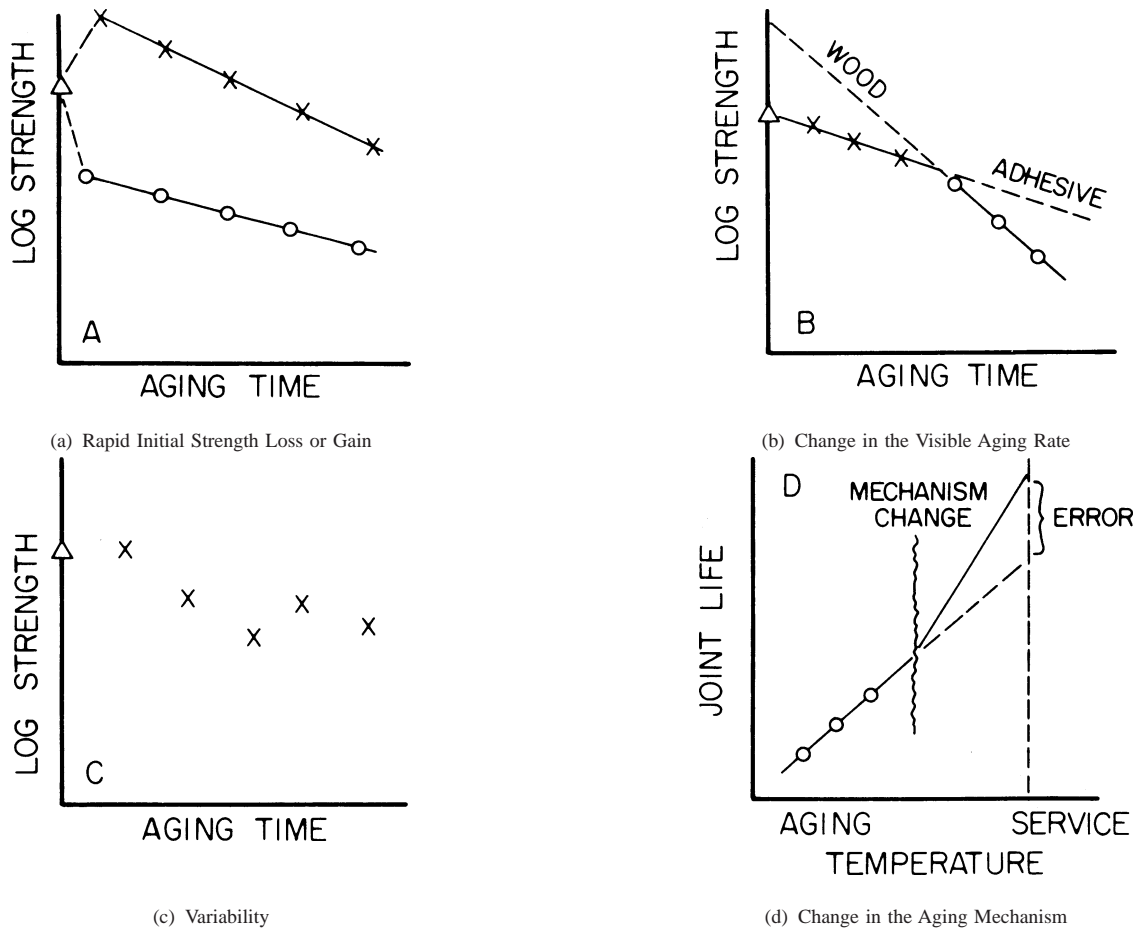

FIG. 5 Schematic Representation of Ideal Log of Time Versus Reciprocal Aging Temperature (T) (Arrhenius Relationship)

- 13.4 Bonding conditions.
 - 13.4.1 Wood moisture content.
 - 13.4.2 Adhesive spread rate.
 - 13.4.3 Open and closed assembly time.
 - 13.4.4 Pressure.
 - 13.4.5 Cure temperature.
 - 13.4.6 Cure time.
- 13.5 Type of test (service life, rate comparison, quality control).
- 13.6 Temperature/moisture levels and aging intervals.
- 13.7 Starting date for each aging exposure.
- 13.8 Results.
 - 13.8.1 Service life tests.
 - 13.8.1.1 $t_{(0.75)}$ for each temperature/moisture condition.
 - 13.8.1.2 The mean percent wood failure for each temperature/moisture condition.
 - 13.8.1.3 Arrhenius equation for each moisture level.
 - 13.8.1.4 Service temperature for each moisture level.
 - 13.8.1.5 Predicted mean service life for each moisture level.
 - 13.8.1.6 The lower 95 % confidence level for service life at each moisture level.

- 13.8.1.7 Result of the plot of residuals to test linearity of the Arrhenius equation at each moisture level.
- 13.8.2 Rate comparison test.
 - 13.8.2.1 Regression equation for the test adhesive and for the standard adhesive.
 - 13.8.2.2 Degradation rate for each adhesive.
 - 13.8.2.3 Average wood failure at each aging interval.
 - 13.8.2.4 Result of the “ F ” test for significance of the difference between the fitted degradation rate equation of the two adhesives.
- 13.8.3 Quality control test.
 - 13.8.3.1 Initial strengths of test and standard adhesives.
 - 13.8.3.2 Wet and dry aging temperatures and aging intervals.
 - 13.8.3.3 Mean strength and wood failure after wet and dry aging.
 - 13.8.3.4 Differences between the strengths of the baseline adhesive and the current adhesive in corresponding tests (such as initial strength).
 - 13.8.3.5 Results of the “ t ” tests for significance of the differences in each pair of strength tests.



ML85 5210

FIG. 6 Schematic Representations of Some Deviations From Ideal Aging Behavior

14. Precision and Bias

14.1 *Precision*—The precision of the degradation rate k or time ($t_{0.75}$) estimates can be checked by standard statistical procedures such as the standard error of the regression coefficient or the standard error of the estimate. There is no standard method for determining the precision of the service life estimate ($SL_{0.75}$) however. The reason is that the Arrhenius relationship (from which the $SL_{0.75}$ is determined) is based on data points ($t_{0.75}$) that are variable and not necessarily independent. Confidence bands on the Arrhenius relationship can be calculated and the lower confidence limit at the service temperature provides a positive estimate of the minimum expected service life,⁶ but this measure of precision may not be acceptable in a rigorous statistical sense.⁶

14.2 Bias:

14.2.1 The bias of the degradation rate, time, or service life estimate can only be determined by actual experience. In the

case of very durable adhesives, the bias may be impossible to determine because degradation is unmeasurable at service temperatures within a reasonable time period.

14.2.2 Little bias was found with certain elastomer-based construction adhesives in exposure to accelerated wet aging and wet aging at service temperature for 11 years.⁷ Some types of adhesives have service lives that equal or exceed wood. The service life of wood ranges from hundreds of years wet to thousands of years dry. Accelerated aging service-life estimates of these adhesives are in reasonable agreement with information about the strength of very old wood.⁸

15. Keywords

15.1 heat resistance; moisture resistance; shear strength

⁶ Millett, M. A., Gillespie, R. H., and Baker, A. J., "Precision of the Rate-Process Method for Predicting Durability of Adhesive Bonds," *Durability of Building Materials and Components, ASTM STP 691*, P. J. Sereda and G. G. Litvan, eds., ASTM, 1980, pp. 913–923.

⁷ River, B. H., "Accelerated Real-Time Service Life Estimates of Elastomer-based Construction Adhesives," *Adhesives Age*, February 1984.

⁸ Gillespie, R. H., "Evaluating Durability of Adhesive-Bonded Wood Joints," *Proceeding Symposium, Wood Adhesives—Research, Application, and Needs*, USDA, Forest Service, Forest Products Laboratory, and Washington State University, Madison, WI, Sept. 23–25, 1980.

ANNEXES

(Mandatory Information)

A1. PROCEDURE FOR USING AGING JARS

A1.1 Pour 125 to 150 mL of the selected saturated salt solution through a long-stem funnel into the aging jar. Add excess salt to the solution to ensure saturation at the aging temperature. Do not spatter or slosh the solution, otherwise salt crystals will form on the side of the jar during aging and may contact the specimens.

A1.2 Place the platform on the silicone rubber ledge. Stack a group of 20 specimens so the bondlines are freely exposed to water vapor.

A1.3 Place the jar in a preheated constant-temperature oven such as described in 6.3.1. Leave the lid open slightly while the jar and its contents heat to oven temperature. After about 15 min of heating, clamp or tighten the lid.

A1.4 When the aging period is over, remove the jar and allow it to cool before opening. It may be necessary to break the rubber seal with a knife point.

A2. PROCEDURES FOR CALCULATING RATE COMPARISONS AND SERVICE-LIFE (VERSION I)

A2.1 *Basic Symbols:*

- Σ = sum of individual values in a group.
- Y = individual log strength value.
- X = individual aging time.
- n = number of values in a group.
- k = number of aging temperatures at a given moisture condition.
- W = \log_{10} failure time ($\log_{10}t_{0.75}$) at given temperature/moisture condition.
- Z = reciprocal of aging temperature $1/(\text{°C} + 273)$.
- pooling = summing calculated values from two sets of regression data.

NOTE A2.1—Refer to Appendix X1 for assistance with the following calculations.

A2.2 *Strength versus Time*—For a given moisture condition, calculate the regression equation $Y = a + bX$ of \log_{10} strength versus aging time for each aging temperature.

A2.2.1 Mean \log_{10} strength:

$$(\bar{Y}) = (\Sigma Y/n)$$

A2.2.2 Mean aging time:

$$(\bar{X}) = (\Sigma X/n)$$

A2.2.3 Corrected total sum of squares for \log_{10} strength (Y TOT SS):

$$Y \text{ TOT SS} = \Sigma Y^2 - \frac{(\Sigma Y)^2}{n}$$

A2.2.4 Corrected sum of squares for aging time (X TOT SS):

$$X \text{ TOT SS} = \Sigma X^2 - \frac{(\Sigma X)^2}{n}$$

A2.2.5 Corrected sum of products for \log_{10} strength and aging time (XY TOT SP):

$$XY \text{ TOT SP} = \Sigma XY - \frac{\Sigma X \Sigma Y}{n}$$

A2.2.6 The regression coefficient (b):

$$b = \frac{XY \text{ TOT SP}}{X \text{ TOT SS}}$$

A2.2.7 The regression constant (a):

$$a = \bar{Y} - b\bar{X}$$

A2.2.8 Let 0.75 (10^a) represent 75 % residual strength, and determine the time to failure ($t_{0.75}$) of the specimens as follows:

$$t_{0.75} = \frac{-0.125}{b}$$

A2.3 *Two Equation Comparison*—Compare two \log_{10} strength versus time regression equations (REG_I and REG_{II}) for the degradation rates of one adhesive at two exposure levels (or for two adhesives at one exposure level) by calculating the following quantities:

A2.3.1 The regression sum of squares (REG SS) for each set of data:

$$REG \text{ SS} = \frac{(XY \text{ TOT SP})^2}{X \text{ TOT SS}}$$

A2.3.2 The error sum of squares (ERR SS) for each set of data:

$$ERR \text{ SS} = Y \text{ TOT SS} - REG \text{ SS}$$

A2.3.3 The degrees of freedom (df) for error sum of squares (ERR SS df) for each set of data:

$$ERR \text{ SS df} = n - 2$$

A2.3.4 The combined error mean square (cERR MS) for the two sets of data:

$$cERR \text{ MS} = \frac{ERR \text{ SS}_{REG I} + ERR \text{ SS}_{REG II}}{ERR \text{ SS df}_{REG I} + ERR \text{ SS df}_{REG II}}$$

A2.3.5 The pooled total sums of squares (p Y TOT SS) for log of strength:

$$p \text{ } Y \text{ TOT SS} = Y \text{ TOT SS}_{REG I} + Y \text{ TOT SS}_{REG II}$$

A2.3.6 The pooled total sums of products (p XY TOT SP):

$$p \text{ } XY \text{ TOT SP} = XY \text{ TOT SP}_{REG I} + XY \text{ TOT SP}_{REG II}$$

A2.3.7 The pooled total sums of squares (p X TOT SS) for aging time:

$$p X \text{ TOT SS} = X \text{ TOT SS}_{\text{REG I}} + X \text{ TOT SS}_{\text{REG II}}$$

A2.3.8 The pooled error sums of squares (p ERR SS):

$$p \text{ ERR SS} = p Y \text{ TOT SS} - \frac{(p XY \text{ TOT SP})^2}{p X \text{ TOT SS}}$$

A2.3.9 The pooled degrees of freedom for error:

$$p \text{ ERR SS df} = (n_{\text{REG I}} + n_{\text{REG II}}) - 3$$

A2.3.10 The pooled error mean squares (p ERR MS):

$$p \text{ ERR MS} = \frac{p \text{ ERR SS}}{p \text{ ERR SS df}}$$

A2.3.11 The difference error mean square for testing the difference in slope of REG I and REG II (SLOPE ERR MS):

$$\text{SLOPE ERR MS} = \frac{c \text{ ERR SS} - p \text{ ERR SS}}{1 \text{ df for slope}}$$

A2.3.12 “F” value attributable to slope:

$$F_{\text{calc}} = \frac{\text{SLOPE ERR MS}}{c \text{ ERR MS}}$$

A2.3.13 Determine the expected value of $F(F_{\text{exp}})$ from a table of the F distribution found in most statistics textbooks. The expected value is located by entering the table at number of degrees of freedom associated with the combined and slope error mean squares. Choose F at 1 df for the slope error mean square and $(n_{\text{REG I}} + n_{\text{REG II}}) - 4$ df for the combined error mean square. Choose the F value corresponding to the 95 % level of probability, and compare it to the F value calculated in A2.3.12.

IF: $F_{\text{exp}} > F_{\text{calc}}$, the slopes of the two regression equations are the same and the levels of the two equations should be tested next.

IF: $F_{\text{exp}} < F_{\text{calc}}$, the slopes are different, so the equations are different and there is no need to test for level.

If the slopes are the same, continue with A2.3.14.

A2.3.14 Combine the individual data from the two original sets of data used for regression Eqs I and II.

A2.3.15 Proceed as if calculating a third regression equation (REG III), and determine its error sum squares (ERR SS_{REG III}) using A2.2.2-A2.2.7 and A2.3.1 to A2.3.2.

A2.3.16 The degrees of freedom for ERR SS_{REG III} (ERR SS df_{REG III}):

$$\text{ERR SS df}_{\text{REG III}} = (n_{\text{REG I}} + n_{\text{REG II}}) - 2$$

A2.3.17 The error mean square for REG III (ERR MS_{REG III}):

$$\text{ERR MS}_{\text{REG III}} = \frac{\text{ERR SS}_{\text{REG III}}}{\text{ERR SS df}_{\text{REG III}}}$$

A2.3.18 The difference error sum of squares for the difference in the levels of REG I and REG II (LEVEL ERR MS):

$$\text{LEVEL ERR MS} = \frac{\text{ERR SS}_{\text{REG III}} - p \text{ ERR SS}}{1 \text{ df for level}}$$

A2.3.19 F value attributable to LEVEL:

$$F_{\text{calc}} = \frac{\text{LEVEL ERR MS}}{p \text{ ERR MS}}$$

A2.3.20 Determine the expected value of $F (F_{\text{exp}})$ as described in A2.3.12 at 1 df for the level error mean square and $(n_{\text{REG I}} + n_{\text{REG II}}) - 3$ df for the pooled error mean square. Select F corresponding to the 95 % level of probability and compare to the value of F calculated above.

IF: $F_{\text{exp}} > F_{\text{calc}}$, the levels are the same and the two groups have the same regressions.

IF: $F_{\text{exp}} < F_{\text{calc}}$, the levels are different and the two groups have different regressions.

A2.4 Arrhenius Equation—Determine the Arrhenius regression equation for time and temperature for a given moisture level as follows:

A2.4.1 Calculate the quantities, regression equation, and time to failure for each temperature for the given moisture level as described in A2.2.1-A2.2.8.

A2.4.2 The reciprocal of the aging temperatures in degrees Kelvin (Z): $Z =$

$$\frac{1}{\text{aging temperature in } ^\circ\text{C} + 273}$$

A2.4.3 The mean of \log_{10} failure time (\bar{W}) (where: $W = t_{0.75}$): (from A2.2.8)

$$\bar{W} = \frac{\sum W}{k}$$

A2.4.4 The mean reciprocal aging temperature (\bar{Z}):

$$\bar{Z} = \frac{\sum Z}{k}$$

A2.4.5 The corrected total sum of squares ($W \text{ TOT SS}$) for log of failure time:

$$W \text{ TOT SS} = \sum W^2 - \frac{(\sum W)^2}{k}$$

A2.4.6 The corrected total sum of squares for reciprocal of aging temperature ($Z \text{ TOT SS}$):

$$Z \text{ TOT SS} = \sum Z^2 - \frac{(\sum Z)^2}{k}$$

A2.4.7 The corrected sum of products for log failure time and reciprocal of aging temperature ($WZ \text{ TOT SP}$):

$$WZ \text{ TOT SP} = \sum WZ - \frac{(\sum W)(\sum Z)}{k}$$

A2.4.8 The regression coefficient (B):

$$B = \frac{WZ \text{ TOT SP}}{Z^2}$$

A2.4.9 The regression constant (A):

$$A = \bar{W} - B\bar{Z}$$

A2.5 Check the fitted Arrhenius equation for linearity.

A2.5.1 Determine predicted failure time \hat{W} at each aging temperature as follows:

$$\hat{W} = A + BZ$$

A2.5.2 Determine residuals at each aging temperature residual = $W - \hat{W}$

A2.5.3 Plot residuals versus aging temperature.

A2.5.4 If points plotted form a pattern (line or curve), the behavior may not fit the Arrhenius relation properly and the

equation should not be extrapolated to a lower service temperature. If points plotted fall at random, the data fit the Arrhenius equation and the fitted equation can be extrapolated to a short distance.

A2.6 Calculate the predicted mean failure time and the lower 95 % confidence limit for a single failure time at the service temperature.

A2.6.1 The predicted mean failure time ($\hat{W}_{service}$) at some service temperature ($Z_{service}$) not more than 50°C lower than the lowest aging temperature.

$$\hat{W}_{service} = A + BZ_{service}$$

A2.6.2 Calculate the lower 95 % confidence limit (lower C.L.) for a single measurement of failure time at the service temperature as follows:

$$\text{lower C.L.} = \hat{W}_{service} - t \sqrt{\text{ERR MS} \left(1 + \frac{1}{k} \frac{(Z_{service} - \bar{Z})^2}{\sum Z^2 - k\bar{Z}^2} \right)}$$

A3. PROCEDURES FOR CALCULATING RATE COMPARISONS AND SERVICE-LIFE (VERSION II)

A3.1 Basic Symbols:

Variables X, Y

Subscripts i, j

$$\sum_{i=1}^n \text{ summation over indices } i = 1, 2, \dots, n$$

A3.2 *Strength versus Time*—Calculate the regression equation as follows:

$$Y_i = a + bX_i$$

A3.2.1 Calculate the regression coefficients a, b using a standard statistical computer package or by hand using the following equations:

$$X_i, Y_i \quad i = 1, \dots, n \text{ data}$$

(read as the mean \bar{X} is equal to the sum of the individual values of X divided by the number of values of X)

$$\bar{X} = \sum_{i=1}^n X_i/n$$

$$\bar{Y} = \sum_{i=1}^n Y_i/n$$

$$b = \left(\sum_{i=1}^n X_i Y_i - n\bar{X}\bar{Y} \right) / \left(\sum_{i=1}^n X_i^2 - n\bar{X}^2 \right)$$

$$a = \bar{Y} - b\bar{X}$$

A3.3 *Aging Time*—Estimate of aging time which represents 25 % strength loss from the following equation:

$$X = (Y - a)/b$$

where:

- X = $X_{0.75}$, the time required for 25 % strength loss,
- Y = \log_{10} (75 % initial strength) = $\log_{10}(0.75 \cdot 10^a)$,
- a = \log_{10} (initial strength), note initial strength = 10^a , and
- b = degradation rate constant.

then:

$$X_{0.75} = -0.125/b$$

A3.4 *Comparing Two Regression Lines*—Fill in the analysis of variance table (Table A3.1) using a standard statistical computer package or by hand, using the following equations:

A3.4.1 Calculate the mean of two $i = 1, 2$ individual groups of data with n specimens per group

$j = 1, 2 \dots, n_i$; where X_{ij}, Y_{ij} is the data set, X = time, Y = \log_{10} (residual strength)

TABLE A3.1 Analysis of Variance Table

Source	Sum of Squares	Degrees of Freedom
Overall regression	(1)	1
Additional intercept	(2)-(1)-(3)+(4)	1
Additional slope	(5)-(4)	1
Error	(3)-(5)	$m - 4$
Total	(2)	$m - 1$

$$\bar{X}_i = \sum_{j=1}^{n_i} X_{ij}/n_i$$

$$\bar{Y}_i = \sum_{j=1}^{n_i} Y_{ij}/n_i$$

and, for the combined groups calculate as follows:

$$\bar{X} = \sum_{i=1}^2 \sum_{j=1}^{n_i} X_{ij}/m$$

where:

$$m = n_1 + n_2$$

$$\bar{Y} = \sum_{i=1}^2 \sum_{j=1}^{n_i} Y_{ij}/m$$

A3.4.2 Calculate slopes and intercepts individual slopes b_i where: $i = 1, 2$

$$b_i = \left(\sum_{j=1}^{n_i} X_{ij} Y_{ij} - n_i \bar{X}_i \bar{Y}_i \right) / \left(\sum_{j=1}^{n_i} X_{ij}^2 - n_i \bar{X}_i^2 \right)$$

and individual intercepts a_i where: $i = 1, 2$

$$a_i = \bar{Y}_i - b_i \bar{X}_i$$

combined slope:

$$b = \left(\sum_{i=1}^2 \sum_{j=1}^{n_i} X_{ij} Y_{ij} - m \bar{X} \bar{Y} \right) / \left(\sum_{i=1}^2 \sum_{j=1}^{n_i} X_{ij}^2 - m \bar{X}^2 \right)$$

and combined intercept:

$$a = \bar{Y} - b \bar{X}$$

A3.4.3 Calculate the following values and enter in analysis of variance table (Table A3.1).

$$b \left(\sum_{i=1}^2 \sum_{j=1}^{n_i} X_{ij} Y_{ij} - m \bar{X} \bar{Y} \right)$$

$$\sum_{i=1}^2 \sum_{j=1}^{n_i} Y_{ij}^2 - m \bar{Y}^2$$

$$\frac{\sum_{i=1}^2 (\sum_{j=1}^{n_i} Y_{ij}^2 - n_i \bar{Y}_i^2)}{(\sum_{i=1}^2 (\sum_{j=1}^{n_i} X_{ij} Y_{ij} - n_i \bar{X}_i \bar{Y}_i))^2 / (\sum_{i=1}^2 (\sum_{j=1}^{n_i} X_{ij}^2 - n_i \bar{X}_i^2))}$$

$$\sum_{i=1}^2 b_i (\sum_{j=1}^{n_i} X_{ij} Y_{ij} - n_i \bar{X}_i \bar{Y}_i)$$

A3.4.4 Analysis of variance:

(i) Test if both slopes are equal

$$F = ((5) - (4)) / [((3) - (5)) / (m - 4)] \text{ compare to } F_{1,m-4}$$

NOTE A3.1—Obtain *F* from a table of “*F*” for 1 and *m* – 4 df.

(ii) If both slopes equal, test for both intercepts equal

$$F = ((2) - (1) - (3) + (4)) / [((3) - (5)) / (m - 4)] \text{ compare to } F_{1,m-4}$$

A3.5 95 % lower confidence band for an observation.

$$X_p, Y_i \quad i = 1, \dots, n \text{ data}$$

where:

$$Y = a + bX \text{ regression line}$$

$$t = t_{n-2}^{0.95} = \text{upper 0.95 value of } t \text{ distribution with } n - 2 \text{ df}$$

$$(\text{ = 1.645 as } n \rightarrow \infty)$$

$$Y_L = \text{lower bound at } X = X_0$$

$$Y_L = a + bX_0 - t \sqrt{(6)}$$

where:

$$(6) = 1 + \frac{1}{n} + (X_0 - \bar{X})^2 (\sum_{i=1}^n X_i^2 - n\bar{X}^2)$$

APPENDIX

(Nonmandatory Information)

X1. TABLE FOR REGRESSION ANALYSIS

X1.1 Strength-time Regression Calculation

- X1.1.1 \bar{Y}
- X1.1.2 \bar{X}
- X1.1.3 *Y* TOT SS
- X1.1.4 *X* TOT SS
- X1.1.5 *XY* TOT SP
- X1.1.6 *b*
- X1.1.7 *a*
- X1.1.8 Eq $Y = a + bX$
- X1.1.9 $t_{0.75}$

X1.2 Comparison of Two Regression Equations

- X1.2.1 REG SS
- X1.2.2 ERR SS
- X1.2.3 ERR SS df
- X1.2.4 *c* ERR MS
- X1.2.5 *p Y* TOT SS
- X1.2.6 *p XY* TOT SP
- X1.2.7 *p X* TOT SS
- X1.2.8 *p* ERR SS
- X1.2.9 *p* ERR SS df
- X1.2.10 *p* ERR MS
- X1.2.11 SLOPE ERR MS
- X1.2.12 *F* for SLOPE
- X1.2.13 *Y* TOT SS for REG III
- X1.2.14 *XY* TOT SP for REG III
- X1.2.15 *X* TOT SS for REG III
- X1.2.16 ERR SS for REG III
- X1.2.17 ERR SS df for REG III

- X1.2.18 ERR MS for REG III
- X1.2.19 LEVEL ERR MS
- X1.2.20 *F* for LEVEL (or ADHESIVE)

X1.3 Arrhenius Equation

X1.3.1 Determine the Arrhenius regression equation at a given moisture level.

- X1.3.1.1 *W* for each temperature _ _ _ _ _
- X1.3.1.2 *Z* for each temperature _ _ _ _ _
- X1.3.1.3 \bar{W}
- X1.3.1.4 \bar{Z}
- X1.3.1.5 *W* TOT SS
- X1.3.1.6 *Z* TOT SS
- X1.3.1.7 *WZ* TOT SP
- X1.3.1.8 *B*
- X1.3.1.9 *A*
- X1.3.1.10 Equation $W = A + BZ$

X1.4 Linearity of Arrhenius Equation

- X1.4.1 Check linearity of fitted Arrhenius equation.
- X1.4.1.1 \hat{W} at each aging temperature _ _ _ _ _
- X1.4.1.2 Residuals _ _ _ _ _

X1.5 Mean Failure Time

- X1.5.1 Calculate predicted mean failure time and lower 95 % confidence limit at some service temperature.
- X1.5.1.1 *Z* service.
- X1.5.1.2 \hat{W} service.
- X1.5.1.3 Lower C.L.

 **D 4502 – 92 (2004)**

ASTM International takes no position respecting the validity of any patent rights asserted in connection with any item mentioned in this standard. Users of this standard are expressly advised that determination of the validity of any such patent rights, and the risk of infringement of such rights, are entirely their own responsibility.

This standard is subject to revision at any time by the responsible technical committee and must be reviewed every five years and if not revised, either reapproved or withdrawn. Your comments are invited either for revision of this standard or for additional standards and should be addressed to ASTM International Headquarters. Your comments will receive careful consideration at a meeting of the responsible technical committee, which you may attend. If you feel that your comments have not received a fair hearing you should make your views known to the ASTM Committee on Standards, at the address shown below.

This standard is copyrighted by ASTM International, 100 Barr Harbor Drive, PO Box C700, West Conshohocken, PA 19428-2959, United States. Individual reprints (single or multiple copies) of this standard may be obtained by contacting ASTM at the above address or at 610-832-9585 (phone), 610-832-9555 (fax), or service@astm.org (e-mail); or through the ASTM website (www.astm.org).