



Standard Test Method for Fracture Strength in Cleavage of Adhesives in Bonded Joints¹

This standard is issued under the fixed designation D 5041; the number immediately following the designation indicates the year of original adoption or, in the case of revision, the year of last revision. A number in parentheses indicates the year of last reapproval. A superscript epsilon (ϵ) indicates an editorial change since the last revision or reapproval.

1. Scope

1.1 This test method covers the determination of fracture strength in cleavage of adhesive bonds when tested on standard reinforced plastic specimens and under specified conditions of preparation and testing (Note 1).

NOTE 1—While this test method is intended for use in reinforced plastic applications, it may be used for measuring fracture properties of adhesives using other plastic adherends, provided consideration is given to the thickness and should be of equal rigidity to the plastic adherends.

1.2 The values stated in SI units are to be regarded as the standard. The values given in parentheses are for information only.

1.3 *This standard does not purport to address all of the safety concerns, if any, associated with its use. It is the responsibility of the user of this standard to establish appropriate safety and health practices and determine the applicability of regulatory limitations prior to use.*

2. Referenced Documents

2.1 ASTM Standards:²

- D 618 Practice for Conditioning Plastics for Testing
- D 907 Terminology of Adhesives
- D 2093 Practice for Preparation of Surfaces of Plastics Prior to Adhesive Bonding
- D 5573 Practice for Classifying Failure Modes in Fiber-Reinforced-Plastic (FRP) Joints
- E 4 Practices for Force Verification of Testing Machines

3. Terminology

3.1 *Definitions*—Many of the terms used in this test method are defined in Terminology D 907.

3.2 *Definitions of Terms Specific to This Standard:*

3.2.1 *failure initiation energy, E_i* —the area under the load deflection curve where the first significant load drop occurs

after the start of the test, showing the onset of permanent damage to the bonded assembly (see Fig. 1).

3.2.2 *failure propagation energy, E_p* —the area under the load-deflection curve beginning at the failure initiation energy and ending at the catastrophic failure of the bonded assembly. (See Fig. 1).

3.2.3 *semirigid*—indicates that the adherends shall have such dimensions and physical properties as to permit bending them through any angle of up to 30° without breaking or cracking.

3.2.4 *semirigid adherend, n* —an adherend that has dimensions and physical properties that permit bending at designated test temperature through any angle up to 30° without breaking or cracking.

3.2.5 *total energy*—failure initiation energy plus failure propagation energy.

4. Significance and Use

4.1 This test method provides a means of measuring the cleavage forces and energies required to fail adhesively bonded reinforced flat bonded specimens. It also offers a semi-quantitative observation of failure mode.

4.2 This test method has found application in screening structural adhesives for bonding reinforced plastics where simple lap shear testing has proven to be inadequate in distinguishing differences between adhesives.

4.3 It is important to note that the test method measures performance properties of the total bonded system (for example, reinforced plastic and adhesive) but will not yield fundamental properties of the adhesive alone.

5. Apparatus

5.1 *Testing Machine*, any suitable testing machine capable of control of constant-rate-of-crosshead movement and comprising essentially the following:

5.1.1 *Drive Mechanism*, a mechanism for imparting to the cross-head movable member, a uniform, controlled velocity with respect to the base (fixed member); this velocity is to be regulated as specified in Section 10.

5.1.2 *Load Indicator*, a mechanism capable of showing the total compressive load carried by the test specimen. The mechanism is to be essentially free from inertia-lag at the specified rate of testing and indicate the load with an accuracy

¹ This test method is under the jurisdiction of ASTM Committee D14 on Adhesives and is the direct responsibility of Subcommittee D14.40 on Adhesives for Plastics.

Current edition approved April 1, 2004. Published April 2004. Originally approved in 1990. Last previous edition approved in 1998 as D 5041 – 98.

² For referenced ASTM standards, visit the ASTM website, www.astm.org, or contact ASTM Customer Service at service@astm.org. For *Annual Book of ASTM Standards* volume information, refer to the standard's Document Summary page on the ASTM website.

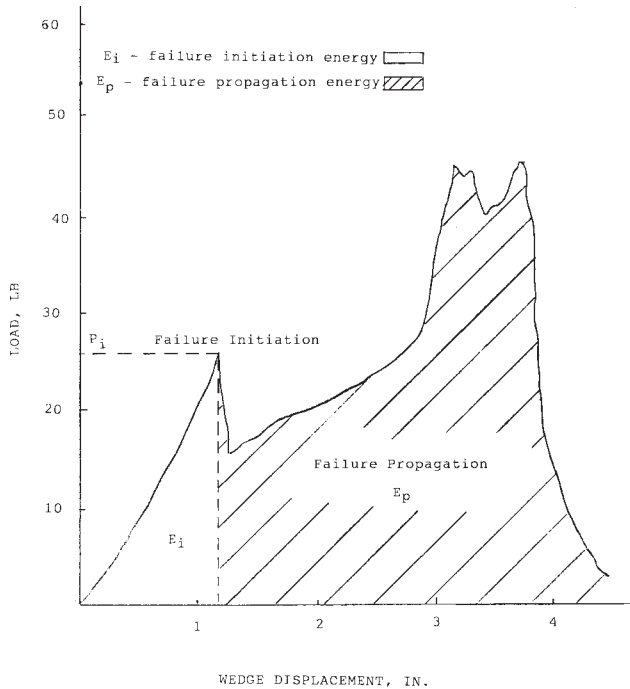

FIG. 1 A Typical Load versus Deflection Curve for Wedge Test

of $\pm 1\%$ of the maximum indicated value of the test (load). Verify the accuracy of the testing machine at least once a year in accordance with Practices E 4.

5.2 *Wedge*, made of either aluminum or steel with an included angle of 45° . The sides of the wedge are machined smooth with the edge having a radius not to exceed 0.02 mm (0.01 in).

NOTE 2—A stainless steel wedge is recommended, has been found to work well, and is very durable. Due to the weight of a steel wedge, the removal of excess metal, which does not adversely affect the stiffness of the wedge, is recommended.

5.3 *Removable Tip (Optional)*—In some cases, the tip of the traveling wedge will strike the adhesive before catastrophic failure. This phenomenon will lead to grossly distorted test data. Should this be a problem in some adhesively bonded assemblies, a removable tip wedge of the design shown in Fig. 2 is suggested.

5.4 *Support Fixture*, an adjustable fixture used to support and center the bonded assembly under the tip of the wedge. See Fig. 3.

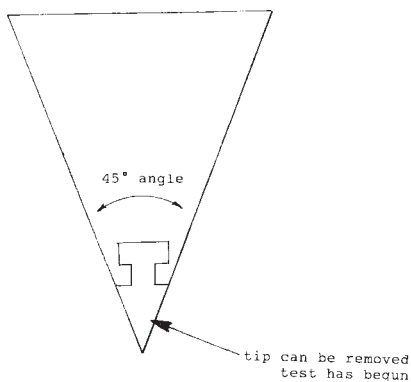

FIG. 2 Wedge with Removable Tip

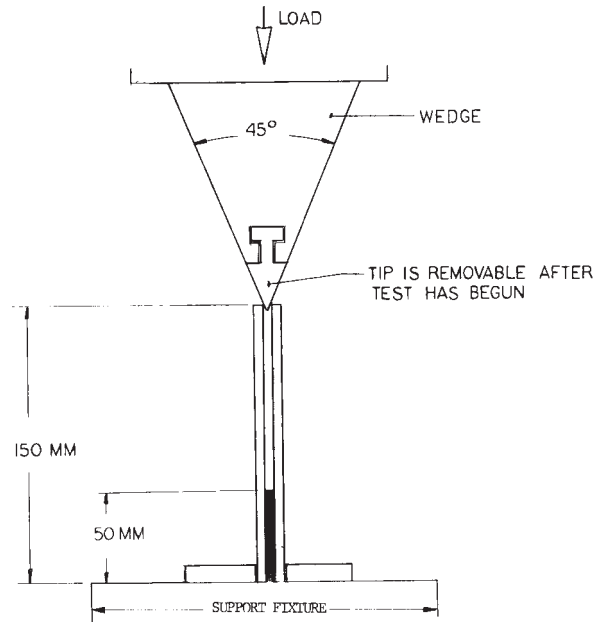

FIG. 3 Test Setup

5.5 *Integrator*, a mechanical or electronic device or computer for the determination of failure energies.

5.6 *Bond Fixture*, any suitable fixture with temperature- and pressure-controlled platens, capable of bonding test assemblies in accordance with the adhesive manufacturer's recommendations.

6. Test Assemblies

6.1 *Flat Adherend*, unless otherwise specified in material specifications, make the test adherends in conformance to the form and dimensions shown in Fig. 4. Cut them from flat semirigid plastic panels having a nominal thickness of 2.54 mm (0.1 in.) $\pm 0.5\%$. Cut adherends into sections, 150 by 150 mm (6 by 6 in.), $\pm 0.5\%$. (See appendix for optional specimen sizes.)

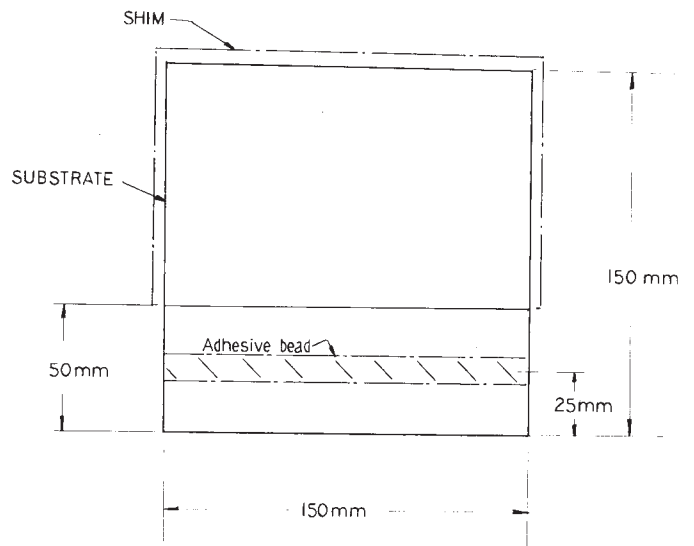

FIG. 4 Placement of Adhesive Bead

7. Preparation

7.1 Laminated test assemblies (Fig. 5) consist of two adherends of similar stiffness properly prepared and bonded together.

NOTE 3—If the bonded test assembly is constructed with adherends of different stiffness, the result is a peel rather than a cleavage test. (For example, higher stiffness promotes cleavage; lower stiffness, peel.)

7.2 Prepare the surface of the substrate prior to bonding in accordance with the adhesive suppliers' recommendations. Typical surface preparations include solvent scrubbing, application of primers and, in some cases, only a dry rag wipe.

NOTE 4—It is important to be aware of potential substrate surface differences. Frequently reinforced plastics have a preferred bonding side. Contact the substrate supplier if there is any doubt.

7.3 Prepare and dispense the adhesive in accordance with adhesive manufacturer's recommendations, or as specified or agreed upon between the buyer and the seller.

7.4 An adhesive bead is applied to the center of the bond area across the full width of the adherend (see Fig. 4). The bondline thickness and flow are controlled by a combination of shims and glass beads. Apply a uniform light coating of 0.76-mm (0.03-in.) glass beads onto the adhesive and position TFE-fluorocarbon or release coated steel shim, as shown, to control final adhesive thickness.

7.5 Mate the two halves of the cleavage assembly as soon as possible after applying the glass beads to form the test assembly shown in Fig. 5. The entire bonded assembly may be wrapped in aluminum foil to protect the heated platens used to cure the adhesive. Cure the adhesive in accordance with the adhesive suppliers' recommendation. Immediately after curing, remove the shims from the bonded assemblies and trim the adhesive squeeze-out. Allow the bonded assemblies to cool and then condition at 23 ± 2°C (73.4 ± 3.6°F) for 24 h and 50 ± 4 % relative humidity prior to postbaking or testing.

7.6 Postbake assemblies (as required) as experienced in end-use (production) or in accordance with the adhesive manufacturer's recommendation.

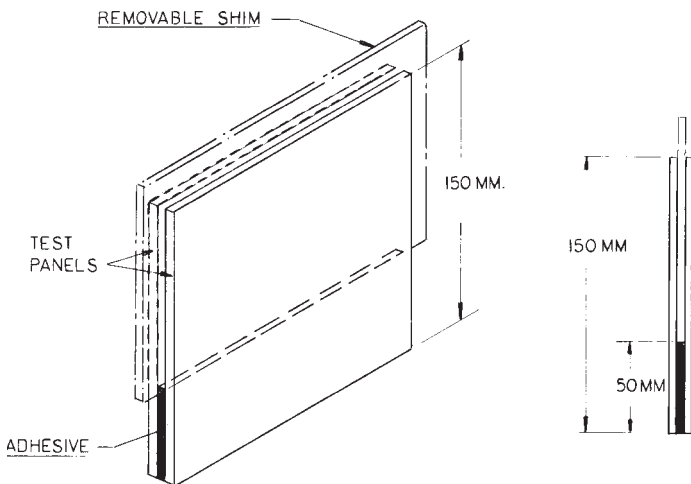

FIG. 5 Test Specimen

8. Number of Test Specimens

8.1 Test at least five specimens for each condition (for example, adhesive, adherend, or specimen preconditioning).

8.2 Discard specimens that break at some obvious flaw and make retests, unless such flaws constitute a variable to be studied.

9. Conditioning

9.1 *Conditioning*— Condition the test specimens at 23 ± 2°C (73.4 ± 3.6°F) and 50 ± 5 % relative humidity for not less than 14 h prior to test in accordance with Procedure A of Practice D 618 for those tests where conditioning is required. In cases of disagreement, the tolerances shall be ±1°C (±1.8°F) and ±2 % relative humidity.

9.2 *Test Conditions*— Conduct tests in the standard laboratory atmosphere of 23 ± 2°C (73.4 ± 3.6°F) and 50 ± 5 % relative humidity, unless otherwise specified. In cases of disagreement, the tolerances shall be ±1°C (±1.8°F) and ±2 % relative humidity.

10. Speed of Testing

10.1 Speed of testing is the relative rate of motion of the test fixtures during the test. Rate of motion of the driven fixture, when the machine is running idle, may be used if it can be shown that the resulting speed of testing is within the limits of variation allowed.

10.2 The standard speed of testing is 127 ± 0.5 mm/min (5.0 in./min),

10.3 The standard chart speed is 250 mm/min (10.0 in./min).

NOTE 5—Direct comparisons of different adhesives can be made only when specimen construction and test conditions are identical.

NOTE 6—Within the limitations imposed by Note 5 other specimen widths may be used, (see appendix) provided the test machine is capable of applying the load uniformly across the width of the adherends.

11. Procedure

11.1 Rigidly fix the wedge and support fixture in the testing machine so that the bonded assembly is vertically aligned between the wedge and support fixture as shown in Fig. 3. The slot in the support fixture must be adjusted to allow for deflection of the adherends and must be at least 0.125 in. greater than the thickness of the test assembly.

11.2 Set speed control to 127 mm/min (5 in./min).

11.3 Set the chart speed to 250 mm/min (10 in./min).

11.4 Set electronic data gathering instrumentation to automatically record the complete load-deformation curve.

11.5 Apply compressive load to the bonded assembly at the specified rate and plot the load-deformation curve.

11.6 When the wedge has penetrated beyond the removable tip, gently remove the tip from the wedge as the test continues until the assembly fails (optional).

11.7 Two areas of interest on the load-deformation curve are failure initiation and failure propagation. The first load drop along the curve shows the onset of permanent damage and is referred to as the failure initiation point. Since this point is sometimes hard to identify, for consistency between laboratories, the first significant drop in load is normally used for the failure initiation point (see Fig. 1).

11.7.1 The failure propagation area begins at the failure initiation point and continues until catastrophic failure of the test assembly. During this time energy is being absorbed by the bonded assembly as the wedge separates the two adherends.

12. Calculation

12.1 In the absence of electronics instrumentation, calculate the failure initiation energy and failure propagation energy by determining the area under the load-deformation curve.

12.2 For the test parameters specified in this test method, the energy/in.² of the chart, beneath the curve, is 0.5 mm/min (5.0 in.-lb/in.²) Energy for subdivisions is determined by the grid size.

13. Report

13.1 Report the following information:

13.1.1 Complete identification of the adhesive tested, including type, source, manufacturer code number, batch or lot number, form, etc.

13.1.2 Complete identification of adherends used, including material, thickness, surface preparation, and orientation.

13.1.3 Description of bonding process, including method of application of adhesive, glue-line thickness, drying or precuring conditions (where applicable), curing time, temperature, and pressure.

13.1.4 Average thickness of adhesive layer after formation of the joint, within 0.025 mm (0.001 in.). Describe the method of obtaining the thickness of the adhesive layer including procedure, location of measurement, and range of measurements.

13.1.5 Complete description of test specimens, including dimensions and construction of test assemblies conditions used for cutting individual test adherends, number of test panels represented, and number of individual test assemblies.

13.1.6 Conditioning procedure used for assemblies prior to testing including any post-bake conditions.

13.1.7 Type of test machine and crosshead rate and chart speed used.

13.1.8 Environmental test conditions.

13.1.9 Type of failure for each individual specimen. For fiber-reinforced-plastic (FRP) adherends such as sheet molding compound (SMC), evaluate failure in accordance with Practice D 5573.

13.1.10 Failure initiation energy and failure propagation energy.

14. Precision and Bias

14.1 Table 1 lists data generated at six different laboratories using a single adhesive, a standard FRP and individual laboratory test apparatus. All bonding was done in Laboratory No. 2 with bonded parts sent to other laboratories. Raw data is on file at ASTM International Headquarters.

15. Keywords

15.1 adhesive; cleavage; fiber-reinforced-plastic; wedge

TABLE 1 Round-Robin Data Conducted at Six Laboratories

Laboratory	Fiber Tear, %	Peak Load, lb	Total Energy, in.-lb	In.-lb Energy at 1-in. Intervals				
				1 in.	2 in.	3 in.	4 in.	Break
1	95	44.6	116.0	12.1	40.6	75.2	108.7	116.0
2	100	41.6	110.7	12.7	43.0	76.6	110.8	110.7
3	80	41.8	109.6	109.6
4	94	46.6	111.2	11.6	42.3	74.6	76.3	111.3
5	100	44.8	118.3	14.6	45.6	...	77.7	117.1
6	96	39.5	120.8	15.7	51.0	87.0	120.8	120.8

APPENDIX

(Nonmandatory Information)

X1. OPTIONAL SPECIMEN SIZES

X1.1 In many cases it is desirable to test parts smaller than 150 by 150 mm (6 by 6 in.). This need could arise from limited availability of substrate, limited access to sufficiently large flat surfaces or real parts, etc. Consequently, reduced size parts may sometimes be tested. Provided test part size is not reduced to less than 50 by 150 mm (2 by 6 in.), the graph (Fig. X1.1),

shown below, illustrates that energy measurements are linear over various part sizes with 50-mm (2-in.) wide bond areas.

X1.2 For proper interpolation of energies, the slope of the line should be determined since it has been established that the relationship is linear (Fig. X1.1 and Fig. X1.2).

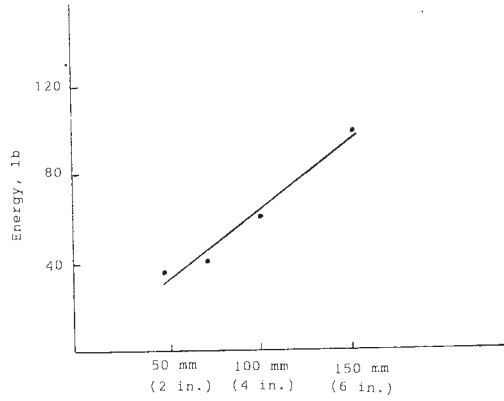

FIG. X1.1 Relationship of Energy to Sample Size

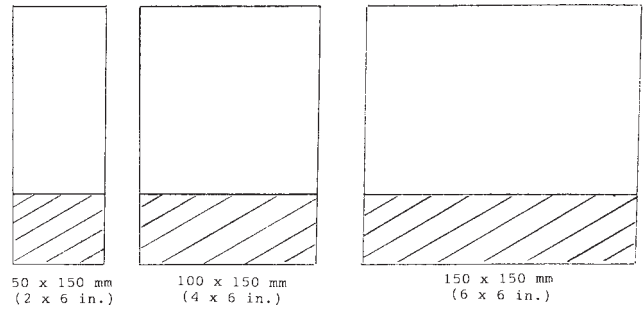

FIG. X1.2 Specimen Sizes

ASTM International takes no position respecting the validity of any patent rights asserted in connection with any item mentioned in this standard. Users of this standard are expressly advised that determination of the validity of any such patent rights, and the risk of infringement of such rights, are entirely their own responsibility.

This standard is subject to revision at any time by the responsible technical committee and must be reviewed every five years and if not revised, either reapproved or withdrawn. Your comments are invited either for revision of this standard or for additional standards and should be addressed to ASTM International Headquarters. Your comments will receive careful consideration at a meeting of the responsible technical committee, which you may attend. If you feel that your comments have not received a fair hearing you should make your views known to the ASTM Committee on Standards, at the address shown below.

This standard is copyrighted by ASTM International, 100 Barr Harbor Drive, PO Box C700, West Conshohocken, PA 19428-2959, United States. Individual reprints (single or multiple copies) of this standard may be obtained by contacting ASTM at the above address or at 610-832-9585 (phone), 610-832-9555 (fax), or service@astm.org (e-mail); or through the ASTM website (www.astm.org).