



Standard Test Method for Strength Properties of Adhesive Bonds in Shear by Compression Loading¹

This standard is issued under the fixed designation D 905; the number immediately following the designation indicates the year of original adoption or, in the case of revision, the year of last revision. A number in parentheses indicates the year of last reapproval. A superscript epsilon (ϵ) indicates an editorial change since the last revision or reapproval.

This standard has been approved for use by agencies of the Department of Defense.

INTRODUCTION

The accuracy of the results of strength tests of adhesive bonds will depend on the conditions under which the bonding process is carried out. Unless otherwise agreed upon by the manufacturer and the purchaser, the bonding conditions shall be prescribed by the manufacturer of the adhesive. In order to ensure that complete information is available to the individual conducting the tests, the manufacturer of the adhesive shall furnish numerical values and other specific information for each of the following variables:

- (1) The moisture content of the wood at the time of gluing.
- (2) Complete mixing directions for the adhesive.
- (3) Conditions for applications of the adhesive including the rate of spread or thickness of film, number of coats to be applied, whether to be applied to one or both surfaces, and the conditions of drying where more than one coat is required.
- (4) Assembly conditions before application of pressure, including the room temperature, length of time, and whether open or closed assembly is to be used.
- (5) Curing conditions, including the amount of pressure to be applied, the length of time under pressure and the temperature of assembly when under pressure. It should be stated whether this temperature is that of the glue line, or of the atmosphere at which the assembly is to be maintained.
- (6) Conditioning procedure before testing, unless a standard procedure is specified, including the length of time, temperature, and relative humidity.

A range may be prescribed for any variable by the manufacturer of the adhesive if it can be assumed by the test operator that any arbitrarily chosen value within such a range or any combination of such values for several variables will be acceptable to both the manufacturer and the purchaser of the adhesive.

1. Scope

1.1 This test method covers the determination of the comparative shear strengths of adhesive bonds used for bonding wood and other similar materials, when tested on a standard specimen under specified conditions of preparation, conditioning, and loading in compression. This test method is intended primarily as an evaluation of adhesives for wood.

1.2 The values stated in SI units are to be regarded as the standard. The values given in parentheses are provided for information purposes only.

1.3 *This standard does not purport to address all of the safety concerns, if any, associated with its use. It is the responsibility of the user of this standard to establish appropriate safety and health practices and determine the applicability of regulatory limitations prior to use.*

2. Referenced Documents

2.1 ASTM Standards:

- D 143 Methods of Testing Small Clear Specimens of Timber²
- D 907 Terminology of Adhesives³

¹ This test method is under the jurisdiction of ASTM Committee D-14 on Adhesives and is the direct responsibility of Subcommittee D14.30 on Wood Adhesives.

Current edition approved April 10, 1998. Published February 1999. Originally published as D 905 – 47 T. Last previous edition D 905 – 94.

² Annual Book of ASTM Standards, Vol 04.10.

³ Annual Book of ASTM Standards, Vol 15.06.

3. Terminology

3.1 *Definitions*—Many terms in this test method are defined in Terminology D 907.

4. Significance and Use

4.1 It cannot be assumed that this test method measures the true shear strength of the adhesive bond. Many factors interfere or bias the measurement including the strength of the wood, the specimen, the shear tool designs themselves, and the rate of loading.

4.1.1 Wood failure is very common in joints made with strong adhesives. Although high wood failure is normally desired, when it occurs the measured strength is lower than the true adhesive bond strength.

4.1.2 Stress concentrations at the notches of the specimen tend to lower the measured strength. In a similar test for the shear strength of solid wood, Methods D 143, these effects are self correcting so that the measured strength is close to the true shear strength of the wood. By analogy the same may be true in this test method, however, other factors are also involved and may alter the relationship.

4.1.3 The rate of loading affects the strength of an adhesive bond according to the adhesive's rheological properties. The more viscoelastic or plastic the adhesive, the greater effect. Thermosetting adhesives like urea- and phenol-formaldehyde are elastic. Their bond strengths can be measured over a range of loading rate from 0.038 to 1.27 cm/min (0.015 to 0.5 in./min) with no apparent affect. Thermoplastic adhesives like polyvinyl acetate, hot melts, and elastomer-based adhesives exhibit a broad range of elastic, viscoelastic, and plastic behaviors. Their bond strengths will be affected to varying degrees by changing the loading rate. Generally, increasing the rate, increases the measured strength.

4.2 This test method is suitable for product research and development, qualifying adhesives in accordance with certain product or performance specifications, and monitoring bonding process control. This test method may be suitable for comparing and selecting adhesives, however, such comparisons must be made with caution since the measured strength of some

adhesives may be different in different types of joints. Strength values obtained by this test method are not suitable as design shear strengths values without adjustment by certain engineering design factors.

5. Apparatus

5.1 The testing machine shall have a capacity of not less than 6810 kg (15 000 lb) in compression and shall be fitted with a shearing tool containing a self-aligning seat to ensure uniform lateral distribution of the load. The machine shall be capable of maintaining a uniform rate of loading such that the load may be applied with a continuous motion of the movable head to maximum load at a rate of 5 mm (0.20 in.)/min with a permissible variation of $\pm 25\%$. The shearing tool shown in Fig. 1 has been found satisfactory. The testing machine shall be located in an atmosphere such that the moisture content of the specimens developed under the conditions prescribed in Section 8 is not noticeably altered during testing.

6. Test Specimens

6.1 Test specimens shall conform to the form and dimensions shown in Fig. 2. The specimens shall be cut from test joints prepared as described in Sections 7 and 8.

6.2 At least 20 specimens shall be tested, representing at least four different joints.

7. Preparation of Test Joints

7.1 Hard maple blocks (*Acer saccharum* or *Acer nigrum*), having a minimum sp gr of 0.65 based on oven-dry weight and volume shall be selected (see Note). These blocks shall be of straight grain and free from defects including knots, birdseye, short grain, decay, and any unusual discolorations within the shearing area. The blocks shall be of suitable size preferably so that five test specimens may be cut from one test joint as shown in Fig. 3. Blocks approximately 19 by 63.5 by 304 mm ($\frac{3}{4}$ by 2½ by 12 in.) have been found to be satisfactory for this purpose. The grain direction shall be parallel to the longest dimension of the block. The blocks shall be at the equilibrium moisture content recommended by the manufacturer of the

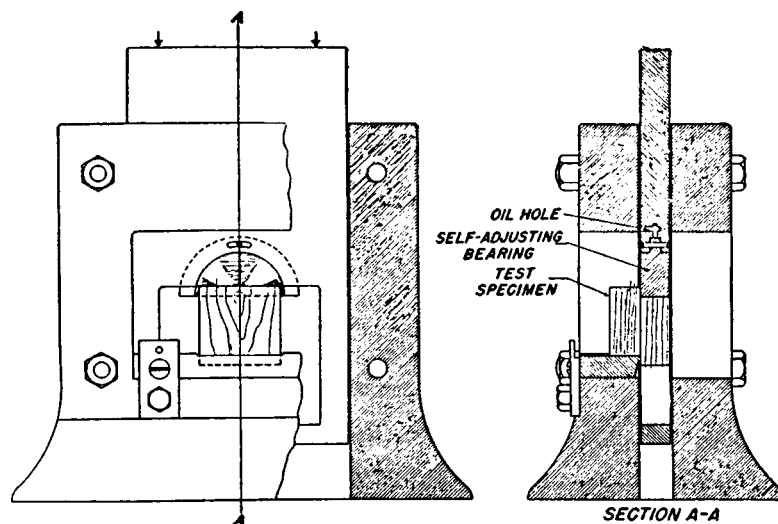
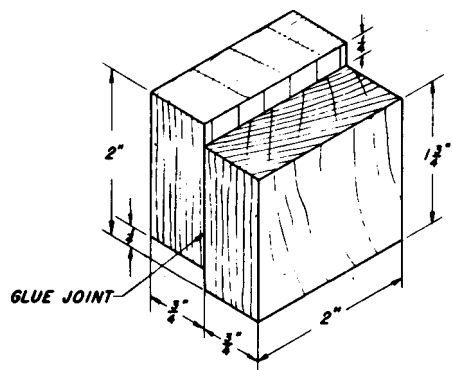

FIG. 1 Shearing Tool



Metric Equivalents

in.	1/4	3/4	1 3/4	2
mm	6.3	19	44.4	50.8

FIG. 2 Form and Dimensions of Test Specimen

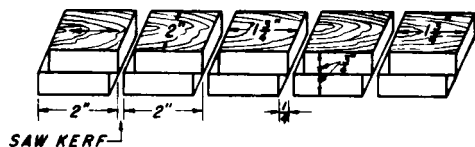

Metric Equivalents

in.	1/4	3/4	1 3/4	2
mm	6.3	19	44.4	50.8

FIG. 3 Test Joint Showing Method of Cutting Five Test Specimens

adhesive. In the absence of such recommendation, the moisture content shall be from 10 to 12 % based on oven-dry weight as determined on representative samples in accordance with the "Moisture Determination" section of Methods D 143. The blocks shall be surfaced, just prior to gluing, preferably with a hand-feed jointer, and the blocks weighed and assembled in pairs so that blocks of approximately the same specific gravity are glued together. The surfaces shall remain unsanded and shall be free from dirt.

NOTE 1—A method for selecting maple blocks of satisfactory specific gravity is described in the Appendix to this method. For referee tests, the specific gravity of blocks may be determined in accordance with the procedure described in the "Specific Gravity and Shrinkage in Volume" section of Methods D 143.

7.2 The adhesive shall be prepared and applied to the blocks in accordance with the procedure recommended by the manufacturer of the adhesive. The glue-coated blocks shall then be assembled and pressed, likewise in accordance with the recommendations of the manufacturer of the adhesive.

8. Conditioning of Test Joints

8.1 The joints, upon removal from pressure shall be conditioned at a relative humidity of $50 \pm 2\%$ and at a temperature of $23 \pm 1^\circ\text{C}$ ($73.4 \pm 2^\circ\text{F}$) either for a period of 7 days or until specimens reach equilibrium as indicated by no progressive changes in weight, whichever is the shorter period. The length of this period of conditioning may be extended beyond this limit by written agreement between the purchaser and the

manufacturer of the adhesive.

9. Preparation of Specimens

9.1 Cut the specimens as shown in Fig. 3 so that the grain direction is parallel to the direction of loading during test. Take care in preparing the test specimens to make the loaded surfaces smooth and parallel to each other and perpendicular to the height. Take care also in reducing the lengths of the laminations to 44.4 mm ($1\frac{3}{4}$ in.) to ensure that the saw cuts extend to, but not beyond, the glue line. Measure the width and length of the specimen at the glue line to the nearest 0.25 mm (0.010 in.) to determine the shear area.

9.2 Retain specimens in the conditioning atmosphere described in Section 8 until tested, except during the cutting operations.

10. Procedure

10.1 Place the test specimen in the shearing tool so that the load may be applied as described in Section 5. The position of the specimen in one type of shearing tool is shown in Fig. 1. Apply the loading with a continuous motion of the movable head at a rate of 5 mm (0.20 in.)/min to failure as prescribed in Section 5.

11. Calculation

11.1 Calculate the shear stress at failure in pounds-force per square inch (or kilopascals) based on the glue line area between the two laminations measured to the nearest 0.06 cm^2 (0.01 in.^2), and report for each specimen together with the estimated percentage of wood failure.

12. Report

12.1 The report shall include the following:

- 12.1.1 Complete identification of the adhesive tested, including type, source, manufacturer's code numbers, form, etc.
- 12.1.2 Application and bonding conditions used in preparing the specimens.
- 12.1.3 Conditioning procedure used for the specimens.
- 12.1.4 Temperature and relative humidity in the test room.
- 12.1.5 Number of specimens tested.
- 12.1.6 Number of joints represented.
- 12.1.7 Maximum and minimum shear stresses at failure and percentages of wood failure. The standard deviation or all individual test values, or both, for the failing load values and wood failure values may be included in the report at the option of either the purchaser or the manufacturer of the adhesive.
- 12.1.8 The average shear stress at failure and the average percentage of wood failure.

13. Precision and Bias

13.1 Precision:

13.1.1 Precision has two components: repeatability at a given test site and reproducibility between test sites. The precision of this test method is affected by many factors including, but not limited to: (1) the wood species, (2) the boards selected, (3) grain direction, (4) growth ring orientation, (5) the quality of the bonded joint, (6) the condition of the shear tool, (7) the precision on the testing machine, and (8) the operator. When the specimen fails primarily in the wood, the

 **D 905**

normally variability of the wood strength affects the precision. The coefficient of variation of shear strength parallel to the grain is 14 % for a given species of wood.

13.1.2 Repeatability at a Given Site:

13.1.2.1 In a study in which all the above factors were closely controlled and the specimens were bonded with phenol-resorcinol formaldehyde adhesive, the coefficient of variation ranged from 2.4 up to 13.0 %, with most values in the range of 3 to 6 %.

13.1.2.2 In a study in which all the above factors, except board and growth ring orientation, were controlled, the coefficients of variation ranged from 8 to 11 % for casein bonded specimens, 4 to 12 % for two polyvinyl acetates, 22 to 27 % for an elastomer-based, and 14 to 21 % for phenol-resorcinol

formaldehyde adhesive bonded specimens.

13.1.3 Reproducibility from site to site:

13.1.3.1 The reproducibility of this test method has not been established.

13.2 *Bias*—Bias is the difference between the true shear strength of the adhesive bond and the strength measured by a method that is repeatable. Bias arises from the design, method, rate of loading the specimen, and from the strength of the wood.

14. Keywords

14.1 adhesive; bond; compression; compression loading; shear; strength properties

APPENDIX

(Nonmandatory Information)

X1. METHOD FOR SELECTING MAPLE BLOCKS OF SATISFACTORY SPECIFIC GRAVITY

X1.1 Cut the hard maple blocks into some standard size such as 19 by 63.5 by 304 mm (¾ by 2½ by 12 in.) after conditioning. Measure the linear dimensions of the blocks in inches, using a suitable caliper or other measuring device. Determine the percentage moisture content of the blocks in accordance with the “Moisture Determination” section of Methods D 143. Do not use these samples in further tests.

X1.2 Calculate the volume of the blocks to the nearest 1 cm³ (0.1 in.³) and express the average percentage moisture content to the nearest whole number. Determine the numerical value of the factor for this moisture content by reference to Table X1.1, which is based on hard maple blocks that have a specific gravity of 0.65 on the oven-dry weight and volume basis and which were conditioned to various moisture content values.

X1.3 Multiply the factor in Table X1.1 by the volume of the block in cubic inches to obtain the weight of the block in grams which would have a specific gravity of 0.65 on the oven-dry

TABLE X1.1 Factors for Corrected Weight in Grams

Moisture Content, %	Factor ^A
4	10.83
5	10.88
6	10.92
7	10.96
8	11.00
9	11.03
10	11.08
11	11.12
12	11.15
13	11.20
14	11.23
15	11.27

^AThese values are the weights of 1 in.³ in sugar maple in grams, at the moisture content values indicated, which would have a sp gr of 0.65 on the oven-dry weight and volume basis.

Weight all blocks to be used in the test at this moisture content; do not use those blocks having a weight less than the above calculated value.

weight and volume basis.

The American Society for Testing and Materials takes no position respecting the validity of any patent rights asserted in connection with any item mentioned in this standard. Users of this standard are expressly advised that determination of the validity of any such patent rights, and the risk of infringement of such rights, are entirely their own responsibility.

This standard is subject to revision at any time by the responsible technical committee and must be reviewed every five years and if not revised, either reapproved or withdrawn. Your comments are invited either for revision of this standard or for additional standards and should be addressed to ASTM Headquarters. Your comments will receive careful consideration at a meeting of the responsible technical committee, which you may attend. If you feel that your comments have not received a fair hearing you should make your views known to the ASTM Committee on Standards, 100 Barr Harbor Drive, West Conshohocken, PA 19428.