



**PDHonline Course S133 (4 PDH)**

---

# **Post-Tensioned Concrete Design Spreadsheet Program**

*Instructor: Matthew Stuart, PE, SE*

**2012**

**PDH Online | PDH Center**

5272 Meadow Estates Drive  
Fairfax, VA 22030-6658  
Phone & Fax: 703-988-0088  
[www.PDHonline.org](http://www.PDHonline.org)  
[www.PDHcenter.com](http://www.PDHcenter.com)

An Approved Continuing Education Provider

**DOCUMENTATION  
FOR  
POST-TENSION  
SPREADSHEET  
PROGRAM**

**BY  
D. MATTHEW STUART**

# TABLE OF CONTENTS

- SCOPE OF PROGRAM
- DESIGN ASSUMPTIONS
- DESIGN METHODOLOGY
- PROGRAM LIMITATIONS
- DESCRIPTION OF INPUT
- DESCRIPTION OF OUTPUT
- HARDWARE REQUIREMENTS
- VARIABLE LIST
- DESIGN EXAMPLE
- MANUAL CALCULATION CHECKS

## DESCRIPTION AND SCOPE OF POST-TENSION SPREADSHEET PROGRAM

.....

THIS SPREADSHEET PROGRAM PROVIDES FOR THE DESIGN AND ANALYSIS OF POST-TENSIONED ONE-WAY BEAM AND SLAB SYSTEMS AND TWO-WAY FLAT PLATE SLAB SYSTEMS. THE PROGRAM IS DIVIDED INTO THREE SEPARATE SCREENS WHICH CORRESPOND TO THE THREE MAJOR AREAS OF CONCERN IN THE DESIGN OF A POST-TENSIONED MEMBER. THESE CATEGORIES ARE SERVICE STRESS ANALYSIS, ULTIMATE MOMENT STRENGTH AND ULTIMATE BEAM SHEAR ANALYSIS. THIS LAST CATEGORY IS FURTHER SUBDIVIDED INTO A SUPPLEMENTAL SCREEN FOR THE DESIGN AND ANALYSIS OF COMBINED ULTIMATE BEAM SHEAR AND TORSION. ALTHOUGH THE SERVICE STRESS AND ULTIMATE MOMENT STRENGTH PORTIONS OF THE PROGRAM ARE CAPABLE OF ANALYZING BOTH ONE-WAY BEAMS AND SLABS AS WELL AS TWO-WAY FLAT PLATES, THE ULTIMATE SHEAR AND SHEAR/TORSION PORTIONS OF THE PROGRAM ARE INTENDED FOR ANALYSIS OF ONE-WAY BEAMS ONLY. ANALYSIS OF THE ULTIMATE SHEAR CAPACITY OF ONE-WAY AND TWO-WAY SLABS IS NOT INCLUDED AS A PART OF THIS PROGRAM. IN ADDITION, ALL ULTIMATE STRENGTH ANALYSIS PORTIONS OF THE PROGRAM ARE INTENDED FOR UNBONDED POST-TENSIONING SYSTEMS ONLY.

THE POST-TENSION SERVICE STRESS PORTION OF THE PROGRAM PROVIDES THE USER WITH THE MINIMUM NUMBER OF STRANDS REQUIRED TO SATISFY THE MAXIMUM ALLOWABLE SERVICE TENSILE STRESS AT THE TENSION FACE OF THE MEMBER UNDER INVESTIGATION. THE USER CAN THEN INPUT THE ACTUAL NUMBER OF STRANDS DESIRED BASED ON THE NUMBER OF STRAND REQUIRED OUTPUT WHILE TAKING INTO CONSIDERATION THE OTHER DESIGN PARAMETERS DISPLAYED. THESE OTHER PARAMETERS INCLUDE THE MINIMUM ALLOWABLE AVERAGE PRESTRESS ( $P/A$ ) AND THE MAXIMUM ALLOWABLE SERVICE COMPRESSIVE STRESS AT THE COMPRESSION FACE OF THE MEMBER. IN ADDITION, INITIAL SERVICE STRESS LEVELS, BOTH ACTUAL AND ALLOWABLE, ARE DISPLAYED AND AUTOMATICALLY COMPARED IN ORDER TO PROMPT A DISPLAY AS REQUIRED FOR BONDED AUXILIARY TENSILE REINFORCING REQUIRED IN THE COMPRESSION FACE OF THE SECTION OR THE MINIMUM  $f'_{ci}$  REQUIRED TO SATISFY THE ACI CODE. IT SHOULD BE NOTED THAT SERVICE STRESSES REFER TO THE CONDITION OF THE MEMBER UNDER FULL SERVICE OR UNFACTORED LOADING WHILE INITIAL STRESSES PERTAIN TO THE CONDITION OF THE MEMBER WHILE IT SUPPORTS ONLY THOSE SERVICE OR UNFACTORED LOADS PRESENT ON THE MEMBER AT THE TIME OF STRESS TRANSFER.

THE UNBONDED ULTIMATE STRENGTH PORTION OF THE PROGRAM PROVIDES THE USER WITH THE MINIMUM BONDED CONVENTIONAL REINFORCING REQUIRED TO SATISFY THE ACI CODE. THE DESIGNER CAN THEN INPUT THE ACTUAL CROSS-SECTIONAL AREA OF BONDED REINFORCING DESIRED BASED ON THE MINIMUM BONDED VALUE OUTPUT WHILE TAKING INTO CONSIDERATION THE OTHER DESIGN PARAMETERS DISPLAYED. THESE OTHER PARAMETERS INCLUDE THE FACTORED NOMINAL MOMENT STRENGTH, THE PURE FLEXURAL CRACKING STRENGTH AND THE REINFORCEMENT RATIOS OF THE SECTION BASED ON BOTH THE NUMBER OF STRANDS DESIRED AS INPUT IN THE SERVICE STRESS PORTION OF THE PROGRAM AND THE DESIRED BONDED REINFORCING INPUT IN THIS PORTION OF THE PROGRAM. THE USER IS PROMPTED TO INCREASE THE REFERENCED DESIRED INPUT VALUES IF ANY OF THESE LATTER PARAMETERS ARE NOT SATISFIED. IN ADDITION SUPPLEMENTAL VARIABLES USED IN THE COMPUTATION OF THE ULTIMATE MOMENT STRENGTH CAPACITY OF THE MEMBER ARE DISPLAYED FOR REFERENCE PURPOSES ONLY. THESE INCLUDE EFFECTIVE AND NOMINAL STRESS LEVELS OF THE POST-TENSIONED STRAND AND SECONDARY EFFECTS INDUCED BY THE PRIMARY POST-TENSIONING MOMENTS. THE ULTIMATE STRENGTH PORTION OF THE PROGRAM CAN BE THOUGHT OF AS A SUBSECTION OF THE SERVICE STRESS PROGRAM PORTION IN THAT INPUT VALUES FROM THIS LATTER PORTION ARE ALSO USED IN THE ULTIMATE STRENGTH CALCULATIONS OF THIS SEGMENT OF THE SPREADSHEET. IT SHOULD ALSO BE NOTED THAT VALUES DISPLAYED FOR MINIMUM BONDED REINFORCEMENT REQUIRED AND THE FACTORED NOMINAL MOMENT STRENGTH,  $\Phi M_n$ , DO NOT INCLUDE ANY BONDED AUXILIARY TENSILE REINFORCEMENT CALLED FOR IN THE SERVICE STRESS PORTION OF THE PROGRAM.

THE ULTIMATE BEAM SHEAR PORTION OF THIS PROGRAM FIRST DETERMINES THE REQUIREMENT FOR SHEAR REINFORCEMENT, IF ANY, FOR THE SECTION IN QUESTION. WITH THE EXCEPTION OF  $d_p$ , SECTION PROPERTIES ARE DERIVED FROM THE APPLICABLE INPUT PARAMETERS FROM

BOTH THE SERVICE STRESS AND ULTIMATE MOMENT PORTIONS OF THE PROGRAM. THE USER IS ABLE TO DETERMINE THE SHEAR REINFORCING REQUIREMENTS AT SIX DIFFERENT SPAN LOCATIONS SIMULTANEOUSLY BY INPUTTING THE CORRESPONDING VALUES OF  $V_u$ ,  $M_u$  AND  $d_p$  FOR THE SEPARATE SPAN LOCATIONS UNDER CONSIDERATION. THE PROGRAM RESPONDS BY DISPLAYING IF SHEAR REINFORCEMENT IS REQUIRED, IF MINIMUM SHEAR REINFORCEMENT IS REQUIRED OR IF NO STIRRUPS ARE REQUIRED. THE USER THEN INPUTS THE BAR SIZE DESIRED AT EACH SPAN LOCATION AND THE PROGRAM RESPONDS BY DISPLAYING THE STIRRUP SPACING REQUIRED TO SATISFY THE ACI CODE BASED ON  $A_{fy}$  OF 60 ksi. THE STIRRUP TYPE ASSUMED BY THE PROGRAM IN CALCULATING THE SPACING REQUIREMENTS IS DISPLAYED GRAPHICALLY ON THE SPREAD SHEET SCREEN AND INCLUDES ONLY TWO VERTICAL LEGS OF THE BAR SIZE INPUT AT EACH STIRRUP LOCATION. THE SCREEN ALSO DISPLAYS MINIMUM STIRRUP SPACING AND MINIMUM  $A_v$  REQUIRED BY CODE. IN ADDITION, SUPPLEMENTAL VARIABLES USED IN THE SHEAR ANALYSIS CALCULATIONS ARE DISPLAYED FOR REFERENCE PURPOSES ONLY. THESE INCLUDE  $V_c$ ,  $V_s$  AND  $\Phi V_n$  AS DEFINED BY ACI 318-83.

THE PROGRAM USER IS DIRECTED TO THE ULTIMATE BEAM SHEAR/TORSION ANALYSIS PORTION OF THE SPREADSHEET FOR THOSE MEMBERS RESISTING APPLIED TORSIONAL MOMENTS. WITH THE EXCEPTION OF MINIMUM AREA AND SPACING OF SHEAR/TORSION REINFORCEMENT REQUIRED BY THE ACI CODE, THIS PORTION OF THE PROGRAM IS BASED ON DESIGN RECOMMENDATIONS OF THE PCI DESIGN HANDBOOK, THIRD EDITION. THIS PROGRAM FIRST DETERMINES IF THE MINIMUM FLEXURAL REINFORCEMENT REQUIREMENTS ARE SATISFIED BASED ON THE DATA INPUT BY COMPARING  $M_u$ ,  $\Phi M_n$  AND  $1.2 M_{ocr}$ . WITH THE EXCEPTION OF INFORMATION PERTAINING TO THE POST-TENSIONING STRANDS OTHER THAN STRAND POSITION, THIS DATA, IS DERIVED FROM THE APPLICABLE PARAMETERS INPUT BY THE USER FOR EACH OF THE SIX SEPARATE SPAN LOCATIONS UNDER CONSIDERATION. FOR BEAM SECTIONS THAT DO NOT MEET THE MINIMUM FLEXURAL REINFORCEMENT REQUIREMENTS, THE USER IS DIRECTED TO INCREASE EITHER THE UNBONDED POST-TENSIONING REINFORCEMENT OR THE BONDED CONVENTIONAL REINFORCEMENT PREVIOUSLY INPUT. THE PROGRAM THEN DETERMINES IF ANY TORSIONAL REINFORCEMENT IS REQUIRED BY COMPARING  $T_u$  INPUT TO THE FACTORED PURE TORSIONAL STRENGTH,  $\Phi * .67 * T_{ocr}$ , OF THE SECTION UNDER REVIEW. IF NO TORSIONAL REINFORCEMENT IS REQUIRED, THE USER IS DIRECTED BACK TO THE BEAM SHEAR PORTION OF THE PROGRAM. FOR BEAMS REQUIRING TORSIONAL REINFORCEMENT, THE PROGRAM EVALUATES THE ANGLE OF INCLINATION TO THE LONGITUDINAL AXIS OF THE MEMBER OF THE DIAGONAL COMPRESSION STRESS. FOR BEAM SECTIONS INPUT THAT DO NOT MEET THE SPECIFIED CRITERIA FOR THE ACCEPTABLE RANGE OF THIS ANGLE ( $\theta$ ), THE USER IS DIRECTED TO INCREASE THE BEAM SECTION. FOR ACCEPTABLE BEAM SECTIONS, THE PROGRAM DETERMINES WHETHER ADEQUATE CONTROL OF DIAGONAL CRACKING AT SERVICE LOADS IS PROVIDED BY THE SECTIONAL PROPERTIES INPUT. THE USER IS AGAIN DIRECTED TO INCREASE THE BEAM SECTION IF THIS CRITERIA IS NOT MET. WHEN ALL OF THE ABOVE DESIGN PARAMETERS ARE SATISFIED, THE PROGRAM CALCULATES AND DISPLAYS THE REQUIRED TORSIONAL AND SHEAR REINFORCEMENT REQUIRED TO SATISFY THE REQUIREMENTS OF THE PCI DESIGN HANDBOOK IN THE FORM OF  $IN^2$  PER FOOT OF BEAM BASED ON  $A_{fy}$  OF 60 ksi. THE USER IS THEN REQUIRED TO INPUT THE BAR SIZE AND STIRRUP TYPE (SEE DISCUSSION OF OUTPUT FOR DESCRIPTION OF STIRRUP TYPE) DESIRED THAT WILL MOST EFFICIENTLY SATISFY THE REINFORCING REQUIREMENTS INDICATED PER FOOT OF BEAM. THE PROGRAM THEN RESPONDS WITH THE STIRRUP SPACING THAT WILL SATISFY THE REQUIRED REINFORCING BASED ON THE STIRRUP SIZE AND TYPE INPUT. FINALLY, THE PROGRAM DETERMINES WHETHER THE LONGITUDINAL FLEXURAL REINFORCEMENT INPUT IS ADEQUATE TO RESIST THE APPLIED MOMENT,  $M_u$ , AND THE AXIAL TENSION CAUSED BY THE SHEAR AND TORSION. FOR SECTIONS THAT DO NOT SATISFY THIS DESIGN REQUIREMENT, THE PROGRAM WILL INDICATE THAT SUPPLEMENTAL LONGITUDINAL REINFORCEMENT IS REQUIRED. THE TYPE AND QUANTITY OF SUPPLEMENTAL REINFORCEMENT REQUIRED IS BEYOND THE SCOPE OF THIS PROGRAM. HOWEVER, THE USER HAS THE OPTION TO INCREASE THE MAIN LONGITUDINAL FLEXURAL REINFORCEMENT AND REITERATE THE SPREAD SHEET INPUT FOR A REVISED DESIGN SOLUTION. IN ADDITION TO THE DISPLAY OUTPUTS DESCRIBED ABOVE, SUPPLEMENTAL VARIABLES USED IN THE SHEAR/TORSION ANALYSIS CALCULATIONS ARE DISPLAYED FOR REFERENCE ONLY. THESE INCLUDE  $A_{oh}$ ,  $\phi$ ,  $f_{ps}$ ,  $t_n$ ,  $V_{ocr}$ ,  $a_o$ ,  $A_o$ ,  $\Delta T_u$  AND  $MIN M_n$  AS DEFINED IN THE PCI DESIGN HANDBOOK.

## DESIGN ASSUMPTIONS

.....

THE FOLLOWING DESIGN ASSUMPTIONS PROVIDE THE BASIS FOR THE ABILITY OF THE USER TO SUCCESSFULLY USE THE POST-TENSIONED SPREADSHEET PROGRAM.

IT IS ASSUMED THAT THE USER HAS ACCESS TO A FRAME ANALYSIS PROGRAM IN ORDER TO PROVIDE MAXIMUM POSITIVE AND NEGATIVE MOMENTS AS WELL AS SHEAR AND MOMENT VALUES AT TENTH POINTS ALONG THE LENGTH OF THE FRAME MEMBERS FOR BOTH GRAVITY AND BALANCING LOADS. IN ADDITION, MAXIMUM NEGATIVE MOMENT VALUES, IF APPLICABLE, SHOULD BE REDUCED TO THE FACE OF THE SUPPORTING MEMBER.

THE USER SHOULD ALSO HAVE AN UNDERSTANDING OF THE LOAD-BALANCING METHOD OF POST-TENSIONING ANALYSIS. BALANCING LOADS USED IN THE FRAME ANALYSIS OF THE STRUCTURE SHOULD BE INPUT AS UNITY ,i.e. FOR ONE STRAND.

THE USER SHOULD HAVE AN UNDERSTANDING OF THE SEPARATE CALCULATIONS REQUIRED TO DETERMINE ALL POST-TENSIONING LOSSES. THIS WOULD INCLUDE FRICTION AND WEDGESET LOSSES AS WELL AS OTHER LONG- AND SHORT-TERM PRESTRESS LOSSES SUCH AS ELASTIC SHORTENING , CREEP AND SHRINKAGE OF CONCRETE AND RELAXATION OF TENDON STRESS. THE USER MUST ALSO BE ABLE TO DETERMINE THE VERTICAL STRAND POSITION WITHIN THE BEAM OR SLAB DUE TO THE PARABOLIC DRAPE NECESSARY TO IMPART THE LOAD-BALANCING EFFECT OF THE POST-TENSIONING STRAND.

SEPARATE CALCULATIONS ARE ALSO REQUIRED TO DETERMINE THE SECTIONAL PROPERTIES OF EACH MEMBER TO BE DESIGNED. THIS WOULD INCLUDE  $S_b$ ,  $S_t$ ,  $A_g$ ,  $h$ ,  $y_b$  AND  $y_t$ .

FINALLY, THE USER SHOULD HAVE ACCESS TO THE THIRD EDITION OF THE PCI DESIGN HANDBOOK IN ORDER TO UNDERSTAND THE TORSIONAL SECTION PROPERTIES REQUIRED FOR INPUT FOR A COMBINED SHEAR/TORSION ANALYSIS.

## DESIGN METHODOLOGY AND APPROACH

.....

THE FORMAT AND SEQUENCE OF THIS PROGRAM HAVE BEEN BASED ON DESIGN EXPERIENCE DERIVED FROM MANUAL CALCULATIONS AND ANALYSES FOR A VARIETY OF POST-TENSIONED STRUCTURES AND MEMBERS I HAVE ENCOUNTERED DURING MY CAREER AS A STAFF AND PROJECT ENGINEER AT ROSS BRYAN ASSOCIATES INCORPORATED. BECAUSE OUR FIRM TYPICALLY HAS BEEN INVOLVED WITH THE DESIGN AND OR ANALYSIS OF ATYPICAL STRUCTURES, IT HAS BEEN OUR EXPERIENCE THAT CANNED PROGRAMS AVAILABLE ON THE MARKET TODAY FOR THE DESIGN OF POST-TENSIONED STRUCTURAL FRAMES ARE NOT FLEXIBLE ENOUGH TO ENABLE ADEQUATE ANALYSIS OF THE WIDE RANGE OF FRAMING CONDITIONS ENCOUNTERED . BECAUSE OF THIS, OUR FIRM RELIES ON A "STRU DL" STRUCTURAL DESIGN LANGUAGE PROGRAM FOR THE MATRIX ANALYSIS OF BUILDING FRAMES AS A SOURCE OF DESIGN ENVELOPES FOR MOMENT, SHEAR AND TORSION APPLIED TO THE RESPECTIVE INDIVIDUAL FRAME MEMBERS. THESE LOADING CRITERIA ARE THEN USED TO DESIGN AND ANALYZE THE BEAM AND SLAB SECTIONS INVOLVED USING THE SPREADSHEET POST-TENSIONING PROGRAM. THE SPREADSHEET FORMAT WAS CHOSEN BECAUSE OF THE ABILITY TO RETAIN INPUT PARAMETERS THAT REMAIN THE SAME FOR DIFFERENT MEMBERS AND DIFFERENT LOCATIONS WITHIN THE SAME SPAN DURING THE DESIGN PROCESS, THEREBY MINIMIZING THE TIME REQUIRED TO SET UP EACH DESIGN RUN. BECAUSE OF THE INTERRELATION AMONG THE THREE MAIN AREAS OF POST-TENSION DESIGN - SERVICE STRESS, ULTIMATE MOMENT AND SHEAR/TORSION STRENGTH ANALYSIS - THE SPREADSHEET FORMAT PROVIDES FOR THE RAPID REVISION OF THE INITIAL INPUT VALUES WHEN ANALYSIS IN A SUBSEQUENT PORTION OF THE SPREADSHEET SCREEN REQUIRES A CHANGE IN THESE SAME INITIAL INPUT PARAMETERS. AN ADVANTAGE OF THE SPREADSHEET FORMAT ALSO IS THE FLEXIBILITY OF THE USER TO CONTROL INPUT VALUES AS REQUIRED TO MEET THE VARYING ASPECTS OF DIFFERENT STRUCTURAL CONSIDERATIONS AS THEY OCCUR IN ADJACENT SPANS AND LOCATIONS WITHIN THE SAME SPAN UNDER CONSIDERATION. THE INSTANTANEOUS OUTPUT RESULTS DISPLAYED AS A RESULT OF INPUT VALUES THAT DEVIATE FROM THE REQUIRED PARAMETERS ARE AN INVALUABLE AID IN QUICKLY ANALYZING THE EFFECTS OF UNUSUAL SITUATIONS THAT ARE IMPOSED FROM ADJACENT SPAN CONSIDERATIONS, REQUIREMENTS OF SEPARATE LOCATIONS WITHIN THE SAME SPAN OR MINIMUM DESIGN REQUIREMENTS OF THE ACI CODE.

TYPICALLY THE NUMBER OF STRANDS REQUIRED TO SATISFY ALLOWABLE SERVICE STRESS LEVELS CONTROLS POST-TENSIONED DESIGN. BECAUSE OF THIS FACT, THE PROGRAM FIRST DETERMINES THE NUMBER OF POST-TENSIONING STRANDS REQUIRED BASED ON THE INITIAL DATA INPUT. THE NEXT AREA OF DESIGN CONCERN THAT TYPICALLY IS ESTABLISHED DURING POST-TENSIONED ANALYSIS IS THE ULTIMATE MOMENT STRENGTH OF THE SECTION UNDER INVESTIGATION. THE SECOND PORTION OR SCREEN OF THE PROGRAM DEALS WITH THE ULTIMATE MOMENT STRENGTH OF MEMBERS REINFORCED WITH UNBONDED POST-TENSIONING TENDONS. THE ANALYSIS OF BONDED POST-TENSIONING SYSTEMS IS NOT INCLUDED AS A PORTION OF THIS PROGRAM BECAUSE THE MAJORITY OF POST-TENSIONED STRUCTURES CONSTRUCTED IN THIS COUNTRY USE UNBONDED STRAND. THE USE OF BONDED STRAND IS TYPICALLY RESTRICTED TO LARGE TRANSFER GIRDERS OR MEMBERS EXPOSED TO CORROSIVE OR EXTREME ENVIRONMENTS, THE FREQUENCY OF WHICH DID NOT JUSTIFY THE INCORPORATION OF THIS SEPARATE TYPE OF ANALYSIS INTO THE PROGRAM. THE SERVICE STRESS AND ULTIMATE MOMENT STRENGTH PORTIONS OF THE PROGRAM WERE DEVELOPED TO INCORPORATE ANALYSIS AT ONLY ONE SPAN LOCATION AT A TIME. THIS RESTRICTION IS DUE TO THE INSUFFICIENT SPACE AVAILABLE ON THE SCREEN MONITOR; HOWEVER THIS IS MORE THAN COMPENSATED FOR BY THE FLEXIBILITY OF THE SPREADSHEET FORMAT AS INDICATED ABOVE.

THE ANALYSIS OF THE ULTIMATE BEAM SHEAR CAPACITY OF THE SECTION IN QUESTION IS DETERMINED IN THE THIRD PORTION OR SCREEN OF THE PROGRAM. AS THIS DESIGN PARAMETER IS THE LEAST LIKELY TO AFFECT THE PREVIOUSLY ESTABLISHED SERVICE STRESS AND ULTIMATE MOMENT STRENGTH CAPACITY OF THE MEMBER, IT IS PLACED NEAR THE CONCLUSION OF THE PROGRAM. AS THE DESIGN REQUIREMENTS FOR A GIVEN BEAM TYPICALLY VARY ACROSS THE SPAN LENGTH OF THE MEMBER BECAUSE OF CHANGING VALUES OF  $V_u$ ,  $M_u$  AND  $d_p$ , THE SCREEN FORMAT WAS SET UP TO INCORPORATE DESIGN CHECKS AT AT A MINIMUM OF SIX DIFFERENT LOCATIONS WITHIN THE SAME SPAN. THE DESIGN OF THE

ULTIMATE SHEAR CAPACITY OF TWO-WAY FLATE PLATE FRAMES IS NOT INCLUDED AS A PORTION OF THIS PROGRAM DUE TO THE COMPLEXITIES OF THE ANALYSIS FOR SUCH A STRUCTURAL SYSTEM.

FOR BEAMS SUBJECTED TO A TORSIONAL MOMENT,THE PROGRAM PROVIDES FOR THE ANALYSIS AND DESIGN OF COMBINED SHEAR AND TORSIONAL LOADING.ALTHOUGH THE ANALYSIS MAY REQUIRE REVISIONS TO THE ORIGINAL INPUT VALUES FOR BOTH POST-TENSIONED AND BONDED REINFORCEMENT,THIS PORTION OF THE PROGRAM OCCURS AT THE CONCLUSION OF THE SPREADSHEET BECAUSE OF THE ADDITIONAL SCREEN/PAGE SPACE REQUIRED BY THE ANALYSIS.AS WITH THE SHEAR ANALYSIS PORTION OF THE PROGRAM,THIS SCREEN ALLOWS FOR THE INPUT OF THE APPROPRIATE DESIGN PARAMETERS AT SIX SEPARATE LOCATIONS WITHIN THE SAME SPAN.

WITH A FEW EXCEPTIONS,THE DESIGN REQUIREMENTS FOR THE SHEAR/TORSION ANALYSIS SECTION OF THE PROGRAM UTILIZE THE COMPRESSION FIELD THEORY PROCEDURES PROVIDED IN THE THIRD EDITION OF THE PCI DESIGN HANDBOOK.DESIGN PROCEDURES IN ALL OTHER SUBSECTIONS OF THE PROGRAM (SERVICE STRESS AND ULTIMATE MOMENT AND SHEAR ANALYSIS) ADHERE TO THE REQUIREMENTS OF ACI 318-83.THE EXCEPTION TO THIS WOULD BE THE MAXIMUM ALLOWABLE SERVICE TENSILE STRESS AT THE EXTREME TENSION FIBER OF THE SECTION IN REVIEW.THE ACI CODE SPECIFIES A VALUE OF  $6*(f'c)^{1/2}$  WHILE THIS PROGRAM USES A LIMIT OF  $7.5*(f'c)^{1/2}$ ,THE RUPTURE MODULUS OF THE CONCRETE.

## PROGRAM LIMITATIONS

.....

MOST OF THE PROGRAM LIMITATIONS ARE A RESULT OF THE LIMITS OF NOT ONLY SPREADSHEET PROGRAMMING BUT ALSO THE SIZE OF THE SCREEN PAGE AVAILABLE FOR VIEWING ON THE COMPUTER TERMINAL.

THE SPREADSHEET PROGRAMMING LANGUAGE USED FOR THE DEVELOPMENT OF THIS PROGRAM DID NOT PROVIDE FOR THE USE OF FOR-NEXT LOOPS. BECAUSE OF THIS, IF-THEN -ELSE STATEMENTS PROVIDED THE BULK OF THE DECISION-MAKING PROCESS IN THE DESIGN LOGIC OF THE PROGRAM. THE SIZE OF INDIVIDUAL CELLS USED FOR IF-THEN-ELSE STATEMENTS ALSO LIMITED THE COMPLEXITY OF ANY PARTICULAR DESIGN CALCULATION. FOR THIS REASON, INDEPENDENT VARIABLES USED IN DESIGN CALCULATIONS ARE OFTEN DETERMINED IN A PORTION OF THE SPREADSHEET NOT NORMALLY VIEWED DURING THE USE OF THE PROGRAM. THESE ISOLATED CELLS OF CALCULATIONS ARE THEN SIMPLY REFERRED TO BY THEIR SPREADSHEET ADDRESS FOR CELL CALCULATIONS THAT RESULT IN DISPLAYS WITHIN THE MAIN SCREEN PORTIONS OF THE PROGRAM, i.e. CELLS A0 THROUGH J114. OTHER THAN THE CELL AUDIT LIST FILE WHICH IS PROVIDED AS A PORTION OF THE PROGRAM DOCUMENTATION, THERE IS NO DISCUSSION OF THE ISOLATED CELLS USED FOR THE CALCULATION OF THE REFERENCED INDEPENDENT VARIABLES.

AS WITH ANY SPREADSHEET PROGRAM, ERROR MESSAGES MAY APPEAR ON THE SCREEN UNTIL ALL APPROPRIATE DATA IS INPUT FOR A PARTICULAR MEMBER TO BE DESIGNED.

OTHER PROGRAM DESIGN LIMITATIONS HAVE BEEN PREVIOUSLY MENTIONED AND ELABORATED ON IN THE PROGRAM OUTPUT AND SCOPE DOCUMENTATION. THIS WOULD INCLUDE NO DESIGN PROVISIONS FOR BONDED POST-TENSIONING STRAND OR THE SHEAR ANALYSIS FOR SLAB SECTIONS.

DESCRIPTION OF INPUT PARAMETERS  
 .....

SCREEN REFERENCE

DESCRIPTION

SPREADSHEET SECTION: POST-TENSION SERVICE STRESS

---

REFERENCE CODE:            BEAM MARK NUMBER OR SPAN LOCATION REFERENCE INFORMATION.

SPAN (ft)=                LENGTH OF SPAN IN FEET UNDER INVESTIGATION.

S<sub>b</sub> (in<sup>3</sup>) =                SECTION MODULUS WITH RESPECT TO BOTTOM OF MEMBER.

S<sub>t</sub> (in<sup>3</sup>) =                SECTION MODULUS WITH RESPECT TO TOP OF MEMBER.

A<sub>g</sub> (in<sup>2</sup>) =                TOTAL CROSS-SECTIONAL AREA OF MEMBER INCLUDING ANY SLAB  
 LOCATED ON EITHER SIDE OF THE BEAM IN QUESTION WITH  
 RESPECT TO ONE-HALF THE CLEAR DISTANCE TO THE NEXT  
 ADJACENT BEAM. THIS VALUE MAY OR MAY NOT COINCIDE WITH THE  
 CROSS-SECTIONAL VALUE USED IN CALCULATING OTHER SECTIONAL  
 PROPERTIES SUCH AS S<sub>b</sub>, S<sub>t</sub>, y<sub>b</sub> AND y<sub>t</sub>.

h (in) =                 TOTAL DEPTH OR THICKNESS OF MEMBER.

y<sub>b</sub> (in) =                DISTANCE FROM CENTROIDAL AXIS OF MEMBER TO EXTREME  
 BOTTOM FIBER OF SECTION.

y<sub>t</sub> (in) =                DISTANCE FROM CENTROIDAL AXIS OF MEMBER TO EXTREME  
 TOP FIBER OF SECTION.

M<sub>s</sub> (KF) =                TOTAL SERVICE MOMENT IN KIP-FEET AT SPAN LOCATION UNDER  
 INVESTIGATION. INPUT POSITIVE VALUE FOR POSITIVE MOMENT  
 REGION OR NEGATIVE VALUE FOR NEGATIVE MOMENT REGION.

M<sub>sDLi</sub>(KF)=                INITIAL SERVICE DEAD LOAD PORTION OF TOTAL MOMENT IN KIP-  
 FEET UNDER INVESTIGATION. INPUT POSITIVE VALUE FOR POSITIVE  
 MOMENT REGION OR NEGATIVE VALUE FOR NEGATIVE MOMENT REGION.  
 INCLUDE ONLY THOSE LOADS PRESENT AT THE TIME OF STRESS  
 TRANSFER.

f'c(psi) =                SPECIFIED 28-DAY COMPRESSIVE STRENGTH OF CONCRETE.

f'ci(psi)=                COMPRESSIVE STRENGTH OF CONCRETE AT TIME OF INITIAL STRESS  
 TRANSFER.

M<sub>b</sub> (KF) =                BALANCING LOAD MOMENT IN KIP-FEET FOR ONE STRAND AT SAME  
 SPAN LOCATION UNDER INVESTIGATION FOR TOTAL SERVICE MOMENT.  
 TYPICALLY VALUE WILL BE NEGATIVE AT POSITIVE SERVICE MOMENT  
 REGIONS OR POSITIVE AT NEGATIVE SERVICE MOMENT REGIONS.

P/T(kips)=                EFFECTIVE POST-TENSIONING FORCE FOR ONE STRAND AT SPAN  
 LOCATION IN QUESTION. VALUE TO INCLUDE ALL LOSSES AS  
 DESCRIBED IN ACI 318-83 (18.6).

A<sub>ps</sub> (in<sup>2</sup>)=                CROSS-SECTIONAL AREA OF ONE STRAND.

INITIAL LOSSES(%)= LOSS OF POST-TENSIONING FORCE BEFORE TIME-DEPENDENT LOSSES. INITIAL ELASTIC SHORTENING AND TENDON RELAXATION WOULD BE EXAMPLES OF ANTICIPATED LOSSES TO BE EXPECTED.

LONGTERMLOSSES(K)= TOTAL LOSSES AS DESCRIBED IN ACI 318-83 (18.6) IN KIPS.

DESIRED NO# OF STRANDS= INPUT TOTAL NUMBER OF STRANDS DESIRED USING NUMBER OF STRANDS REQ'D AND P/A OUTPUT AS GUIDELINES.

SPREADSHEET SECTION: UNBONDED ULTIMATE STRENGTH

---

ONE-WAY BM/SLAB INDICATES STRUCTURE TYPE.0=NO;1=YES

TWO-WAY PLATE INDICATES STRUCTURE TYPE.0=NO;1=YES

ULTIMATE LOAD FACTOR=RATIO OF TOTAL ULTIMATE MOMENT TO TOTAL SERVICE MOMENT AT SPAN LOCATION UNDER INVESTIGATION.

bw(in) = WEB WIDTH FOR BEAMS,PANEL WIDTH FOR SLABS.

bf(in) = WIDTH OF EFFECTIVE T-BEAM FLANGE,WIDTH OF RECTANGULAR BEAM OR PANEL WIDTH FOR SLABS.

dp(in) = DISTANCE FROM EXTREME FIBER IN COMPRESSION TO CENTROID OF POST-TENSIONING STRAND.

d (in) = DISTANCE FROM EXTREME FIBER IN COMPRESSION TO CENTROID OF CONVENTIONAL TENSION REINFORCEMENT.

e (in) = DISTANCE BETWEEN CENTROIDAL AXIS OF MEMBER AND CENTROID OF POST-TENSIONING STRAND.INPUT ABSOLUTE VALUE OF STRAND ECCENTRICITY.

hf(in) = THICKNESS OF FLANGE FOR T-BEAM SECTION.INPUT VALUE OF ZERO FOR RECTANGULAR BEAMS AND SLAB SECTIONS.INPUTTING A VALUE EQUAL TO h FOR RECTANGULAR BEAMS AND SLABS WILL RESULT IN OUTPUT DATA FOR REINFORCING RATIOS.

DESIRED REINF. As(in2) = INPUT DESIRED TOTAL AREA OF CONVENTIONAL TENSION REINFORCING AT fy OF 60 ksi.

SPREADSHEET SECTION: ULTIMATE BEAM SHEAR ANALYSIS

---

DISTANCE DIMENSIONAL REFERENCE INFORMATION.DISTANCE FROM LEFT OR RIGHT SUPPORT POINT TO SPAN LOCATION UNDER INVESTIGATION.

Vu(kips) FACTORED TOTAL ULTIMATE SHEAR FORCE AT SPAN LOCATION UNDER CONSIDERATION.

Mu(KF) FACTORED TOTAL ULTIMATE MOMENT IN KIP-FEET AT SPAN LOCATION CORRESPONDING TO Vu UNDER CONSIDERATION.INPUT NEGATIVE OR POSITIVE VALUE FOR REFERENCE ONLY.

dp(in) DISTANCE FROM EXTREME FIBER IN COMPRESSION TO CENTROID OF POST-TENSIONING STRAND AT SPAN LOCATION CORRESPONDING

TO  $V_u$  UNDER CONSIDERATION.

BAR SIZE                   ASTM STANDARD REINFORCING BAR SIZE.INPUT RANGE;#3-#6.

SPREADSHEET SECTION: ULTIMATE BEAM SHEAR/TORSION ANALYSIS

---

DISTANCE                   DIMENSIONAL REFERENCE INFORMATION.DISTANCE FROM LEFT OR RIGHT SUPPORT POINT TO SPAN LOCATION UNDER INVESTIGATION.

$V_u$ (kips)                   FACTORED TOTAL ULTIMATE SHEAR FORCE AT SPAN LOCATION UNDER CONSIDERATION.

$M_s$ (KF)                   TOTAL SERVICE MOMENT IN KIP-FEET AT THE SPAN LOCATION CORRESPONDING TO  $V_u$  UNDER CONSIDERATION.INPUT POSITIVE VALUE FOR POSITIVE MOMENT REGION OR NEGATIVE VALUE FOR NEGATIVE MOMENT REGION.

$T_u$ (KF)                   FACTORED TOTAL ULTIMATE TORSIONAL MOMENT IN KIP-FEET AT THE SPAN LOCATION CORRESPONDING TO  $V_u$  UNDER INVESTIGATION.

$M_b$ (KF)                   THE TOTAL BALANCING LOAD MOMENT IN KIP-FEET AT THE SPAN LOCATION CORRESPONDING TO  $V_u$  UNDER INVESTIGATION.

$A_c$ (in<sup>2</sup>)                   THE AREA ENCLOSED BY THE PERIMETER OF THE CONCRETE CROSS SECTION AS DEFINED BY  $P_c$ .THIS GROSS AREA SHOULD INCLUDE THE AREA OF ANY ENCLOSED VOIDS.

$P_c$ (in)                   THE OUTSIDE PERIMETER OF THE CONCRETE CROSS SECTION.FOR T-BEAM SECTIONS THIS IS AS DEFINED IN ACI 318-83 (11.6.1).

$b_v$ (in)                   THE MINIMUM EFFECTIVE WEB WIDTH WITHIN DEPTH  $d_v$ .THIS VALUE ASSUMES SPALLING OF THE UNRESTRAINED CONCRETE COVER AS SHOWN IN Fig. 4.4.1 OF THE PCI DESIGN HANDBOOK,THIRD EDITION.

$d_v$ (in)                   EFFECTIVE SHEAR DEPTH EQUAL TO THE VERTICAL DISTANCE BETWEEN THE CENTERS OF THE LONGITUDINAL BARS IN THE CORNERS OF THE CLOSED BEAM STIRRUPS.SEE Fig. 4.4.1 OF THE PCI DESIGN HANDBOOK.

$d_p$ (in)                   DISTANCE FROM EXTREME FIBER IN COMPRESSION TO CENTROID OF POST-TENSIONING STRAND AT THE SPAN LOCATION CORRESPONDING TO  $V_u$  UNDER CONSIDERATION.

$e$ (in)                   DISTANCE BETWEEN CENTROIDAL AXIS OF MEMBER AND CENTROID OF POST-TENSIONING STRAND.INPUT ABSOLUTE VALUE OF STRAND ECCENTRICITY.

$V_p$ (kips)                   VERTICAL COMPONENT OF THE EFFECTIVE POST-TENSIONING FORCE AT THE SPAN LOCATION CORRESPONDING TO  $V_u$  IN CONSIDERATION.

$A_s$ (in<sup>2</sup>)                   INPUT THE TOTAL AREA OF CONVENTIONAL TENSION REINFORCING PROVIDED AT THE CORRESPONDING SPAN LOCATION OF  $V_u$  UNDER INVESTIGATION.

d(in) DISTANCE FROM EXTREME FIBER IN COMPRESSION TO CENTROID OF CONVENTIONAL TENSION REINFORCING AT THE SPAN LOCATION CORRESPONDING TO  $V_u$  UNDER CONSIDERATION.

BAR SIZE ASTM STANDARD REINFORCING BAR SIZE.INPUT RANGE;#3-#6.

BAR TYPE INPUT A,B OR C.TYPE A;SINGLE STIRRUP LEG CONTINUOUS AROUND PERIMETER OF BEAM SECTION.  
TYPE B;SINGLE STIRRUP LEG CONTINUOUS AROUND PERIMETER OF BEAM SECTION WITH TWO ADDITIONAL INTERIOR VERTICAL STIRRUP LEGS FOR SHEAR CAPACITY ONLY.  
TYPE C;DOUBLE STIRRUP LEGS CONTINUOUS AROUND PERIMETER OF BEAM SECTION WITH TWO ADDITIONAL INTERIOR STIRRUP LEGS FOR SHEAR CAPACITY ONLY.

.....

DESCRIPTION OF OUTPUT

SCREEN REFERENCE

DESCRIPTION  
(DISCUSSION AND MATHEMATICAL FORMULAS)

SPREADSHEET SECTION: POST-TENSION SERVICE STRESS

NUMBER OF STRANDS REQ'D= THE NUMBER OF STRANDS REQUIRED TO PROVIDE A NET TENSILE STRESS EQUAL TO THE RUPTURE MODULUS OF THE SPECIFIED CONCRETE STRENGTH AT THE TENSION FACE OF THE SECTION IN QUESTION.

$$= ((Ms*12)-(St*7.5*(f'c)^{1/2}))/((Mb*12)+((St*Fp)/Ag))$$

WHERE: St=SECTION MODULUS WITH RESPECT TO THE FLEXURAL TENSION FACE OF SECTION.  
Fp=EFFECTIVE POST-TENSIONING FORCE;P/T.

fa(P/A) (psi) = THE EFFECTIVE COMPRESSIVE STRESS OF THE THE SECTION DUE TO THE AXIAL LOADING THAT RESULTS FROM THE POST-TENSION COMPRESSION FORCE AT SERVICE LOADS.

$$= Fp/Ag$$

WHERE: Fp=EFFECTIVE POST-TENSION FORCE;P/T.

NOTE: THE PROGRAM ALSO DISPLAYS THE MINIMUM ALLOWABLE 'P/A' SPECIFIED BY ACI 318-83 (18.12.4).THE USER SHOULD REFER TO SECTION (7.12.3.1) OF THE ACI CODE FOR SECTIONS WHERE SHRINKAGE AND TEMPERATURE REQUIREMENTS CONTROL HOWEVER.

STRESS AT fb (psi) = THE ACTUAL SERVICE AND INITIAL STRESS LEVELS AT THE EXTREME BOTTOM FIBER OF THE SECTION IN QUESTION BASED ON THE DESIRED NUMBER OF STRANDS INPUT.THE SERVICE STRESS VALUE SHOULD BE COMPARED TO THE APPROPRIATE ALLOWABLE STRESS LEVEL TO VERIFY THAT THE NUMBER OF STRANDS INPUT IS ADEQUATE.THE INITIAL STRESS VALUE CALCULATED IS AUTOMATICALLY COMPARED TO THE APPROPRIATE ALLOWABLE STRESS .VALUES THAT EXCEED THE ALLOWABLE WILL PROMPT A SCREEN DISPLAY INDICATING EITHER THE BONDED AUXILIARY TENSILE REINFORCEMENT REQUIRED AS PER ACI 318-83 (18.4.1) OR THE MINIMUM f'ci REQUIRED TO SATISFY THE SAME REFERENCED CODE SECTION.

$$SERVICE = ((DNS*Fp*1000)/Ag)-((Ms*12000)/Sb)-((Mb*DNS*12000)/Sb)$$

$$INITIAL = (DNS*((Fp+LTL)*(1-(IL/100)))*(1000/Ag))-((MsDLi*12000)/Sb)-(Mb*((Fp+LTL)/Fp)*(1-(IL/100)))*DNS*12000/Sb)$$

WHERE: DNS=DESIRED NUMBER OF STRANDS INPUT.  
Fp=EFFECTIVE POST-TENSIONING FORCE;P/T.

LTl=LONGTERMLOSSES.  
IL=INITIAL LOSSES.

STRESS AT ft (psi) = THE ACTUAL SERVICE AND INITIAL STRESS LEVELS AT THE EXTREME TOP FIBER OF THE SECTION IN QUESTION BASED ON THE DESIRED NUMBER OF STRANDS INPUT. THE SERVICE STRESS VALUE SHOULD BE COMPARED TO THE APPROPRIATE ALLOWABLE STRESS LEVEL TO VERIFY THAT THE NUMBER OF STRANDS INPUT IS ADEQUATE. THE INITIAL STRESS VALUE CALCULATED IS AUTOMATICALLY COMPARED TO THE APPROPRIATE ALLOWABLE STRESS. VALUES THAT EXCEED THE ALLOWABLE WILL PROMPT A SCREEN DISPLAY INDICATING EITHER THE BONDED AUXILIARY TENSILE REINFORCEMENT REQUIRED AS PER ACI 318-83 (18.4.1) OR THE MINIMUM  $f'_{ci}$  REQUIRED TO SATISFY THE SAME REFERENCED CODE SECTION.

$$\text{SERVICE} = ((\text{DNS} * \text{Fp} * 1000) / \text{Ag}) + ((\text{Ms} * 12000) / \text{St}) + ((\text{Mb} * \text{DNS} * 12000) / \text{St})$$

$$\text{INITIAL} = (\text{DNS} * ((\text{Fp} + \text{LTL}) * (1 - (\text{IL} / 100))) * (1000 / \text{Ag})) + ((\text{MsDLi} * 12000) / \text{St}) + (\text{Mb} * ((\text{Fp} + \text{LTL}) / \text{Fp}) * (1 - (\text{IL} / 100))) * \text{DNS} * 12000 / \text{St}$$

WHERE: DNS=DESIRED NUMBER OF STRANDS INPUT.  
Fp=EFFECTIVE POST-TENSIONING FORCE;P/T.  
LTl=LONGTERMLOSSES.  
IL=INITIAL LOSSES.

#### ALLOWABLE STRESS:

SERVICE:f/tension(psi)= TENSILE STRESS EQUAL TO RUPTURE MODULUS OF SPECIFIED CONCRETE STRENGTH.

$$= 7.5 * (f'c)^{1/2}$$

f/comp.(psi) = MAXIMUM COMPRESSIVE STRESS SPECIFIED BY ACI 318-83 (18.4.2 (a)).

$$= .45 * f'c$$

INITIAL:f/tension(psi)= MAXIMUM TENSILE STRESS SPECIFIED BY ACI 318-83 (18.4.1 (b)).

$$= 3 * (f'ci)^{1/2}$$

f/comp.(psi) = MAXIMUM COMPRESSIVE STRESS SPECIFIED BY ACI 318-83 (18.4.1 (a)).

$$= .60 * f'ci$$

Asreq'd = BONDED AUXILIARY TENSION REINFORCEMENT REQUIRED WHEN COMPUTED INITIAL TENSILE STRESSES EXCEED THE ALLOWABLE.

$$\text{w/ RESPECT TO BOTTOM} = (((|f_{bi}| / ((|f_{bi}| + |f_{ti}|) / h)) * |f_{bi}|) / 2) * b_w) / 30000$$

$$\text{w/ RESPECT TO TOP} = (((|f_{ti}| / ((|f_{ti}| + |f_{bi}|) / h)) * |f_{ti}|) / 2) * b_f) / 30000$$

WHERE:  $f_{bi}$ =INITIAL STRESS AT EXTREME BOTTOM FIBER.  
 $f_{ti}$ =INITIAL STRESS AT EXTREME TOP FIBER.

NOTE:FOR T-BEAM SECTIONS, WHEN THE DEPTH OF THE TENSILE STRESS BLOCK EXCEEDS THE FLANGE THICKNESS AT NEGATIVE MOMENT REGIONS OR THE DEPTH OF THE BEAM LESS THE FLANGE THICKNESS AT POSITIVE MOMENT REGIONS A SCREEN DISPLAY OF 'NOT CALC' IS PROMPTED INDICATING MANUAL CALCULATION OF  $A_{sreq'd}$  IS REQUIRED.

$f'_{cimin}$  = THE MINIMUM  $f'_{ci}$  REQUIRED WHEN COMPUTED INITIAL COMPRESSIVE STRESS EXCEEDS THE ALLOWABLE.

w/ RESPECT TO BOTTOM =  $f_{bi}/.60$

w/ RESPECT TO TOP =  $f_{ti}/.60$

WHERE:  $f_{bi}$ =INITIAL STRESS AT EXTREME BOTTOM FIBER.  
 $f_{ti}$ =INITIAL STRESS AT EXTREME TOP FIBER.

#### SPREADSHEET SECTION: UNBONDED ULTIMATE STRENGTH

---

SPAN/DEPTH RATIO = RATIO OF THE SPAN LENGTH TO THE TOTAL DEPTH OF THE MEMBER IN QUESTION.

=  $(l \cdot 12)/h$

WHERE:  $l$ =SPAN (ft).

MINIMUM BONDED  $A_s(in^2)$  = THE MINIMUM AREA OF BONDED REINFORCEMENT REQUIRED BY ACI 318-83 (18.9) AT A SPECIFIED YIELD STRENGTH OF 60 ksi .

ONE-WAY BEAM/SLAB= SEE ACI 318-83 EQUATION (18-6).

TWO-WAY FLAT PLATE= SEE ACI 318-83 EQUATION (18-7) FOR POSITIVE MOMENT REGION OR EQUATION (18-8) FOR NEGATIVE MOMENT REGION.

$P_{ps}$ = RATIO OF POST-TENSIONING REINFORCEMENT.

=  $A_{ps}/b \cdot d_p$

WHERE:  $A_{ps}$ =TOTAL AREA OF POST-TENSIONING REINFORCEMENT  
 $b$ =WIDTH OF COMPRESSION FACE OF MEMBER.

$f_{se}$  (ksi) = EFFECTIVE STRESS IN POST-TENSIONING REINFORCEMENT AFTER ALLOWANCE FOR ALL LOSSES.

=  $F_p/A_{ps}$

WHERE:  $F_p$ =EFFECTIVE POST-TENSIONING FORCE;P/T.

$f_{ps}$  (ksi) = STRESS IN POST-TENSIONING REINFORCEMENT AT NOMINAL STRENGTH.

= SEE ACI 318-83 EQUATION (18-4) FOR SPAN-TO-DEPTH RATIO OF 35 OR LESS OR EQUATION (18-5) FOR SPAN-TO-DEPTH RATIO GREATER THAN 35.

$w$  = AS DEFINED IN ACI 318-83 CHAPTER 18.

$$= p \cdot f_y / f'c$$

WHERE:  $p$ =RATIO OF BONDED TENSILE REINFORCEMENT.

$$w_p =$$

AS DEFINED IN ACI 318-83 CHAPTER 18.

$$= P_{ps} \cdot f_{ps} / f'c$$

$$w + w_p =$$

AS DEFINED IN ACI 318-83 CHAPTER 18.

$$= w + w_p$$

$$\text{MAX } w + w_p =$$

SEE ACI 318-83 (18.8.1).

$$= .36 \cdot B_1$$

WHERE:  $B_1$ =FACTOR DEFINED IN ACI 318-83 (10.2.7.3).

NOTE: IF THE RATIO OF POST-TENSIONED AND BONDED REINFORCEMENT EXCEEDS THE MAXIMUM ALLOWED BY ACI 318-83 (18.8.1) THEN THE SCREEN IS PROMPTED TO DISPLAY A MESSAGE THAT THE SECTION IS OVERREINFORCED. THIS IN TURN PROMPTS THE PROGRAM TO DISPLAY THE VALUE FOR THE MAXIMUM FACTORED ULTIMATE MOMENT STRENGTH OF THE SECTION BASED ON THE COMPRESSION PORTION OF THE MOMENT COUPLE. THIS VALUE IS CALCULATED FROM FORMULAS PROVIDED IN SECTION 18.8.2 OF THE COMMENTARY ON ACI 318-83 AND IS EXPRESSED IN TERMS OF KIP-FEET ADJACENT TO THE DISPLAY 'MAX  $\Phi M_n$  = '.

$$\text{SECONDARY EFFECT (KF)} =$$

IN CONTINUOUS ,OR INDETERMINATE POST-TENSIONED STRUCTURES, THE MOMENTS DUE TO POST-TENSIONING ARE USUALLY NOT DIRECTLY PROPORTIONAL TO THE TENDON ECCENTRICITY WITH RESPECT TO THE NEUTRAL AXIS OF THE MEMBER AS THEY ARE WITH SIMPLE SPAN MEMBERS. THIS DIFFERENCE OCCURS BECAUSE THE DEFORMATIONS IMPOSED BY POST-TENSIONING ARE RESISTED BY THE CONTINUOUS MEMBERS AT THE POINTS OF INTERSECTION (BEAM/COLUMN JOINTS) WITH OTHER MEMBERS IN THE STRUCTURE. THIS RESTRAINT MODIFIES THE REACTIONS AND THEREBY AFFECTS THE ELASTIC MOMENTS AND SHEARS RESULTING FROM THE POST-TENSIONING. THE MOMENTS RESULTING FROM THIS RESTRAINT ARE COMMONLY REFERRED TO AS SECONDARY MOMENTS. THIS TERM IS USED BECAUSE THE MOMENTS ARE INDUCED BY THE PRIMARY POST-TENSIONING MOMENTS,  $P_e$ , AND NOT BECAUSE THE SECONDARY MOMENT IS NEGLIGIBLE OR SMALLER THAN THE PRIMARY MOMENT.

$$+ \text{ MOMENT REGION } = ((e/12) \cdot F_p \cdot D_{NS}) + (M_b \cdot D_{NS})$$

$$- \text{ MOMENT REGION } = (M_b \cdot D_{NS}) - ((e/12) \cdot F_p \cdot D_{NS})$$

WHERE:  $F_p$ =EFFECTIVE POST-TENSION FORCE;  $P/T$   
 $D_{NS}$ =DESIRED NUMBER OF STRANDS INPUT.

$$M_u \text{ (KF)} =$$

THE TOTAL FACTORED ULTIMATE MOMENT INCLUDING ALL SECONDARY EFFECTS IN KIP-FEET.

$$= (M_s * ULF) + SE$$

WHERE: ULF=ULTIMATE LOAD FACTOR INPUT.

SE=SECONDARY EFFECT CALCULATED BY PROGRAM.

$\Phi M_n$  (KF) =

THE FACTORED ULTIMATE MOMENT CAPACITY IN KIP- FEET OF THE SECTION UNDER INVESTIGATION BASED ON THE DESIRED NUMBER OF STRANDS AND BONDED REINFORCEMENT INPUT BY THE USER.

= THIS VALUE IS CALCULATED FROM FORMULAS PROVIDED IN SECTION 18.7.1 (A) OF THE COMMENTARY ON ACI 318-83.

NOTE: IF  $M_u$  EXCEEDS  $\Phi M_n$  THEN THE PROGRAM PROMPTS THE SCREEN TO DISPLAY A MESSAGE INDICATING THAT THE BONDED AND OR POST-TENSIONING REINFORCEMENT MUST BE INCREASED. IF  $\Phi M_n$  IS GREATER THAN OR EQUAL TO  $M_u$  THEN THE MESSAGE DISPLAYED INDICATES THAT THE REINFORCEMENT INPUT IS ADEQUATE.

$1.2 * M_{ocr}$  (KF) =

1.2 \* THE PURE FLEXURAL CRACKING STRENGTH AS DEFINED BY ACI 318-83 (18.8.3).

= SEE EQUATION (4.4.2) OF THE PCI DESIGN HANDBOOK THIRD EDITION.

NOTE: AS WITH  $\Phi M_n$  THE PROGRAM IS PROMPTED TO DISPLAY MESSAGES OF COMPLIANCE WITH OR DEVIATION FROM THE REQUIREMENTS OF ACI 318-83 (18.8.3) IN ORDER TO DIRECT THE USER TO INCREASE THE REINFORCEMENT INPUT OR NOT.

#### SPREADSHEET SECTION: ULTIMATE BEAM SHEAR ANALYSIS

---

$V_c$ (kips)

NOMINAL SHEAR STRENGTH PROVIDED BY THE CONCRETE SECTION AT SPAN LOCATION UNDER INVESTIGATION.

= SEE ACI 318-83 EQUATION (11-10).

$V_{cMIN}$ (K)

MINIMUM NOMINAL SHEAR STRENGTH IN KIPS OF CONCRETE SECTION AS PER ACI 318-83 (11.4.1).

$$= 2 * (f'c)^{1/2} * b_w * d$$

WHERE:  $d = d_p$  OR  $(.8 * h)$ , WHICHEVER IS GREATER.

$V_{cMAX}$ (K)

MAXIMUM NOMINAL SHEAR STRENGTH IN KIPS OF CONCRETE SECTION AS PER ACI 318-83 (11.4.1).

$$= 5 * (f'c)^{1/2} * b_w * d$$

WHERE:  $d = d_p$  OR  $(.8 * h)$ , WHICHEVER IS GREATER.

STIRRUPS

PROGRAM CALCULATIONS PROMPT ONE OF THE FOLLOWING SCREEN DISPLAYS; REQ'D, MIN, OR N/R. THESE DISPLAYS CORRESPOND TO; SHEAR REINFORCEMENT IS REQUIRED, MINIMUM SHEAR REINFORCEMENT IS REQUIRED AND NO SHEAR REINFORCEMENT IS REQUIRED RESPECTIVELY. THE

DETERMINATION OF WHICH DISPLAY IS APPROPRIATE FOR THE SPAN LOCATION UNDER INVESTIGATION IS BASED ON THE REQUIREMENTS OF ACI 318-83 (11.1.1) IN CONJUNCTION WITH THE MINIMUM SHEAR REINFORCING REQUIREMENTS OF SECTION (11.5.5.1).HOWEVER THE EXCEPTIONS ALLOWED BY ARTICLES (b) and (c) OF THIS SAME CODE SECTION ARE NOT INCLUDED WITHIN THE CALCULATION PARAMETERS OF THIS PROGRAM.

= SEE ACI 318-83 EQUATIONS (11-1) AND (11-2).

BAR AREA

BASED ON THE STANDARD ASTM REINFORCING BAR SIZE INPUT THE PROGRAM DISPLAYS THE APPROPRIATE CROSS-SECTIONAL AREA OF ONE BAR (in<sup>2</sup>).

= .11 FOR #3,.20 FOR #4,.31 FOR #5 AND .44 FOR #6 BAR.

NOTE:THE PROGRAM WILL PROMPT A DISPLAY OF 'N/A' IF A BAR SIZE OTHER THAN #3,#4,#5 OR #6 IS USED AS THE BAR SIZE INPUT VALUE.

MIN SPCG

SPACING LIMITS FOR SHEAR REINFORCEMENT SPECIFIED IN ACI 318-83 ARE DISPLAYED IN INCHES.

= SEE ACI 318-83 (11.5.4.1).

REQ'D SPCG(in)

BASED ON THE REQUIREMENTS OF ACI 318-83 (11.1.1) THE PROGRAM CALCULATES THE REQUIRED SPACING OF THE STIRRUP SIZE INPUT BY THE USER .IF THE PROGRAM HAS DETERMINED PREVIOUSLY THAT NO SHEAR REINFORCEMENT IS REQUIRED OR THAT MINIMUM SHEAR REINFORCEMENT REQUIREMENTS APPLY AT THE SPAN LOCATION IN CONSIDERATION THEN THE MINIMUM SPACING REQUIREMENTS OF CODE SECTION (11.5.4.1) ARE DISPLAYED.A DISPLAY OF 'REQ'D' IN THE 'STIRRUP' DISPLAY ROW AT THE SPAN LOCATION UNDER REVIEW WILL RESULT IN THE PROGRAM CALCULATING THE REQUIRED STIRRUP SPACING IN INCHES.

= SEE ACI 318-83 EQUATION (11-17),(11-2) AND (11-1).

NOTE:IF SHEAR REINFORCEMENT IS REQUIRED AS INDICATED BY THE 'REQ'D' DISPLAY THEN THE SPACING VALUE DISPLAYED MAY OR MAY NOT BE GREATER THAN THE MINIMUM SPACING REQUIRED BY THE ACI 318-83 CODE. THE USER IS DIRECTED TO COMPARE THE SPACING VALUE DISPLAYED TO THE MINIMUM SPACING REQUIREMENTS THAT ARE ALSO DISPLAYED TO INSURE THAT THE ACTUAL STIRRUP SPACING USED ON CONTRACT DOCUMENTS CONFORMS TO THE ACI CODE.

AvMIN(in<sup>2</sup>)

TO SATISFY THE REQUIREMENTS OF ACI 318-83 (11.5.5.4) THE PROGRAM CALCULATES AND DISPLAYS THE MINIMUM AREA OF SHEAR REINFORCING ,Av AS DEFINED IN CHAPTER 11 OF THE REFERENCED CODE BASED ON THE SPACING VALUE DISPLAYED IN THE 'REQ'D SPCG(in)' ROW.

= SEE ACI 318-83 EQUATION (11-15).

Vs(kips) THE PROGRAM CALCULATES AND DISPLAYS THE VALUE FOR Vs AS DEFINED IN CHAPTER 11 OF ACI 318-83 BASED ON THE BAR SIZE INPUT AND THE SPACING VALUE DISPLAYED IN THE 'REQ'D SPCG(in)' ROW.

= SEE ACI 318-83 EQUATION (11-17).

PhiVn(K) THE PROGRAM DISPLAYS THE VALUE FOR THE FACTORED NOMINAL SHEAR STRENGTH AS DEFINED IN ACI 318-83 (11.1.1) FOR THE SECTION UNDER INVESTIGATION.

= SEE ACI 318-83 EQUATION (11-2) .

SPREADSHEET SECTION: ULTIMATE BEAM SHEAR/TORSION ANALYSIS

---

Aoh(in<sup>2</sup>) THE AREA ENCLOSED BY THE STIRRUP CENTERLINE.SEE Fig. 4.4.1 OF THE PCI DESIGN HANDBOOK THIRD EDITION.

=  $bv \cdot dv$

ph(in) THE PERIMETER OF THE STIRRUP CENTERLINE.SEE Fig. 4.4.1 OF THE PCI DESIGN HANDBOOK.

=  $(2 \cdot bv) + (2 \cdot dv)$

fps(ksi) STRESS IN POST-TENSIONING REINFORCEMENT AT NOMINAL STRENGTH AT THE SPAN LOCATION UNDER REVIEW.

= SEE ACI 318-83 EQUATION (18-4) FOR SPAN-TO-DEPTH RATIO OF 35 OR LESS OR EQUATION (18-5) FOR SPAN-TO-DEPTH RATIO GREATER THAN 35.

Mu(KF) THE TOTAL FACTORED ULTIMATE MOMENT INCLUDING ALL SECONDARY EFFECTS IN KIP-FEET AT THE SPAN LOCATION UNDER INVESTIGATION.

=  $(Ms \cdot ULF) + SE$

WHERE: ULF=ULTIMATE LOAD FACTOR INPUT IN THE UNBONDED ULTIMATE STRENGTH SPREAD SHEET SECTION.  
SE=SECONDARY EFFECT CALCULATED BY PROGRAM AT SPAN LOCATION UNDER CONSIDERATION.

PhiMn(KF) THE FACTORED ULTIMATE MOMENT CAPACITY IN KIP-FEET OF THE SECTION IN QUESTION AT THE SPAN LOCATION UNDER INVESTIGATION BASED ON THE DESIRED NUMBER OF STRANDS AND BONDED REINFORCEMENT INPUT BY THE USER.

= THIS VALUE IS CALCULATED FROM FORMULAS PROVIDED IN SECTION 18.7.1 (A) OF THE COMMENTARY ON ACI 318-83.

1.2\*Mocr(KF) 1.2 \* THE PURE FLEXURAL CRACKING STRENGTH AS DEFINED BY ACI 318-83 (18.8.3).

= SEE EQUATION (4.4.2) OF THE PCI DESIGN HANDBOOK THIRD EDITION.

\*INCREASE REINF. PROGRAM CALCULATIONS PROMPT ONE OF THE FOLLOWING

SCREEN DISPLAYS;YES OR NO.THESE DISPLAYS CORRESPOND TO ;ADDITIONAL REINFORCEMENT IS REQUIRED OR ADDITIONAL REINFORCEMENT IS NOT REQUIRED TO SATISFY THE REQUIREMENTS OF ACI 318-83 (18.8.3) AT THE SPAN LOCATION UNDER CONSIDERATION.THE ASTERISK TO THE LEFT OF THE ROW HEADING 'INCREASE REINF.' REFERS TO THE DISPLAY AT THE FAR RIGHT OF THE SAME ROW INDICATING THE INCREASED REINFORCING REQUIRED IS '(FLEXURAL)'.

= SEE ACI 318-83 (18.8.3) FOR THE CRITERIA OF EVALUATION BETWEEN  $\Phi$  AND  $1.2M_{ocr}$ .

$\Phi \cdot .67 T_{ocr}(KF)$

IN A STATICALLY INDETERMINATE STRUCTURE WHERE REDUCTION OF TORSIONAL MOMENT IN A MEMBER CAN OCCUR DUE TO REDISTRIBUTION OF INTERNAL FORCES THE MAXIMUM FACTORED TORSIONAL MOMENT  $T_u$ , AT WHICH TORSION MAY BE NEGLECTED MAY BE REDUCED TO THE STRENGTH REDUCTION FACTOR  $\Phi$ ,  $\cdot (.67 T_{ocr})$  PROVIDED THAT THE CORRESPONDING ADJUSTMENTS TO THE MOMENTS AND SHEARS IN ADJOINING MEMBERS ARE MADE. $T_{ocr}$  EQUALS THE PURE TORSIONAL CRACKING STRENGTH OF THE MEMBER IN QUESTION.

= SEE EQUATION (4.4.4) OF THE THIRD EDITION OF THE PCI DESIGN HANDBOOK.

$T_u$  REINF. REQ'D

PROGRAM CALCULATIONS PROMPT ONE OF THE FOLLOWING SCREEN DISPLAYS;YES OR NO.THESE DISPLAYS CORRESPOND TO; TORSIONAL REINFORCING IS OR IS NOT REQUIRED TO SATISFY THE REQUIREMENTS OF SECTION 4.4.2 OF THE THIRD EDITION OF THE PCI DESIGN HANDBOOK AT THE SPAN LOCATION IN CONSIDERATION.THE ASTERISK TO THE LEFT OF THE ROW HEADING ' $T_u$  REINF. REQ'D' REFERS TO THE DISPLAY AT THE FAR RIGHT OF THE SAME ROW INDICATING THE TORSIONAL REINFORCING REFERRED TO IS CLOSED '(STIRRUPS).

= SEE SECTION 1.5 OF THE "PROPOSED DESIGN RECOMMENDATIONS FOR BEAMS IN SHEAR AND TORSION" FROM COLLINS AND MITCHELL, "SHEAR AND TORSION DESIGN OF PRESTRESSED AND NON-PRESTRESSED BEAMS", PCI JOURNAL, V.25, NO.5, SEPT-OCT, 1980.

$t_n$ (ksi)

NOMINAL SHEAR STRESS AT THE SPAN LOCATION IN QUESTION.

= SEE EQUATION (4.4.8) OF THE THIRD EDITION OF THE PCI DESIGN HANDBOOK.

THETA MIN

MINIMUM ANGLE OF INCLINATION TO LONGITUDINAL AXIS OF MEMBER (IN DEGREES) OF DIAGONAL COMPRESSION STRESS.

= SEE EQUATION (4.4.11) OF THE PCI DESIGN HANDBOOK.

THETA MAX

MAXIMUM ANGLE OF INCLINATION TO LONGITUDINAL AXIS OF MEMBER (IN DEGREES) OF DIAGONAL COMPRESSION STRESS.

= SEE EQUATION (4.4.12) OF THE PCI DESIGN HANDBOOK.

INCREASE SECTION

PROGRAM CALCULATIONS PROMPT ONE OF THE FOLLOWING SCREEN DISPLAYS;YES OR NO.THESE DISPLAYS CORRESPOND TO ;YES ,INCREASE THE SIZE OF THE SECTION UNDER REVIEW

OR NO, THE SECTIONAL SIZE AS INPUT IS ADEQUATE. THE DETERMINATION OF ADEQUACY OF THE SECTION UNDER CONSIDERATION IS BASED ON THE RECOMMENDATIONS OF SECTION 4.4.2 OF THE THIRD EDITION OF THE PCI DESIGN HANDBOOK.

= IF THETA MIN > THETA MAX THEN DIAGONAL CRUSHING OF THE CONCRETE SECTION INDICATES THAT THE CROSS-SECTIONAL SIZE OF THE MEMBER IN QUESTION IS INADEQUATE TO CARRY THE APPLIED TORSION.

NOTE: THE DISPLAY AT THE FAR RIGHT OF THIS ROW, (SEE NOTE 1), REFERS TO THE NOTE THAT APPEARS AT THE BOTTOM OF THIS SPREAD SHEET SECTION. THIS NOTE REFERS TO SECTION 4.4.2 OF THE PCI DESIGN HANDBOOK WHICH REQUIRES A COMPARISON OF THETA MAX AND MIN TO ENSURE THAT THE TRANSVERSE REINFORCEMENT WILL YIELD BEFORE DIAGONAL CRUSHING OF THE CONCRETE SECTION OCCURS.

\*THETA (DEGREES)

WHEN THETA MIN IS LESS THAN OR EQUAL TO THETA MAX A VALUE OF THETA SHOULD BE CHOSEN SUCH THAT THETA MIN < THETA < THETA MAX. SELECTING A LOWER VALUE OF THETA WILL RESULT IN LESS STIRRUP REINFORCEMENT BUT MORE LONGITUDINAL REINFORCEMENT. THEREFORE THE PROGRAM SELECTS THE AVERAGE VALUE OF THETA MIN AND THETA MAX THEREBY ENSURING A PRUDENT PORTIONING OF TRANSVERSE TO LONGITUDINAL REINFORCING. THE ASTERISK TO THE LEFT OF THE ROW HEADING 'THETA (DEGREES)' REFERS TO THE DISPLAY AT THE FAR RIGHT OF THE SAME ROW WHICH INDICATES THAT THE THETA VALUE CALCULATED IS IN FACT THE AVERAGE OF THETA MIN AND MAX.

= (THETA MIN + THETA MAX) / 2

Vocr (kips)

PURE SHEAR CRACKING STRENGTH.

= SEE EQUATION (4.4.3) OF THE THIRD EDITION OF THE PCI DESIGN HANDBOOK.

INCREASE SECTION

PROGRAM CALCULATIONS PROMPT ONE OF THE FOLLOWING SCREEN DISPLAYS; YES OR NO\*. THESE DISPLAYS CORRESPOND TO; YES, INCREASE THE SIZE OF THE SECTION UNDER REVIEW OR NO THE SECTIONAL SIZE AS INPUT IS ADEQUATE. THE DETERMINATION OF ADEQUACY OF THE SECTION UNDER CONSIDERATION IS BASED ON THE RECOMMENDATIONS OF SECTION 4.4.2 OF THE PCI DESIGN HANDBOOK.

= TO ENSURE ADEQUATE CONTROL OF DIAGONAL CRACKING AT SERVICE LOADING THE CRACKING LOAD SHOULD EXCEED THE SERVICE LOAD. IF THE CRACKING LOAD DOES NOT EXCEED THE SERVICE LOAD, ADEQUATE CONTROL OF DIAGONAL CRACKING AT SERVICE LOAD WILL BE PROVIDED IF THE STRAIN IN THE TRANSVERSE REINFORCEMENT IS NOT EXCESSIVE. THE RELATIONSHIP BETWEEN THE CRACKING LOAD,  $V_{cr}$ , AND THE SERVICE LOAD,  $(V_u/ULF)$  IS FIRST COMPARED BY THE PROGRAM WHERE  $V_{cr}$  IS DETERMINED FROM EQUATION (4.4.1) OF THE PCI DESIGN HANDBOOK AND  $(V_u/ULF)$  ARE CALCULATED FROM THE INPUT VALUE FOR  $V_u$  AT THE APPROPRIATE SPAN LOCATION AND  $ULF$ , ULTIMATE LOAD FACTOR, IS DERIVED FROM

THE UNBONDED ULTIMATE STRENGTH PORTION OF THE PROGRAM. IF  $V_{cr}$  IS GREATER THAN OR EQUAL TO  $(V_u/ULF)$  THEN THE PROGRAM PROMPTS THE 'NO\*' DISPLAY. THE ASTERISK REFERS TO THE DISPLAY AT THE FAR RIGHT OF THE SAME ROW WHICH INDICATES ' $V_{cr} > V_s$ ' WHERE  $V_s$  EQUALS THE SERVICE LOAD OR SHEAR,  $(V_u/ULF)$ , AT THE SPAN LOCATION UNDER INVESTIGATION. IF  $V_{cr} < V_s$  THEN THE PROGRAM CHECKS FOR EXCESSIVE STRAIN IN TRANSVERSE REINFORCEMENT BY COMPARING  $\tan(\theta)$  TO THE FORMULA PROVIDED IN STEP 5 (a.) OF SECTION 4.4.2 OF THE PCI DESIGN HANDBOOK FOR  $f_y=60$  ksi. IF THIS PORTION OF THE ANALYSIS IS ALSO SATISFIED THEN THE PROGRAM AGAIN PROMPTS THE 'NO\*' DISPLAY. IF  $\tan(\theta)$  IS LESS THAN THE REFERENCED FORMULA THEN THE PROGRAM COMPARES  $\theta_{MAX}$  TO THE SAME FORMULA. IF  $\tan(\theta_{MAX})$  IS GREATER THAN OR EQUAL TO THE REFERENCED FORMULA THEN THE PROGRAM PROMPTS A DISPLAY OF '\*NO'. THIS VARIATION OF A 'NO' DISPLAY SHOULD ALERT THE USER TO THE FACT THAT THE  $\theta$  ASSUMED BY THE PROGRAM IN SUBSEQUENT CALCULATIONS EQUALS  $\theta_{MAX}$  RATHER THAN  $(\theta_{MIN} + \theta_{MAX})/2$ . A FINAL CONDITION THAT MUST ALSO BE MET TO SATISFY THE RECOMMENDATIONS OF THE PCI DESIGN HANDBOOK IS THE REQUIREMENT THAT THE SPACING OF ALL TRANSVERSE AND LONGITUDINAL REINFORCING NOT EXCEED 12 INCHES. MINIMUM SPACING REQUIREMENTS OF TRANSVERSE REINFORCEMENT ARE DISPLAYED IN ANOTHER PORTION OF THIS PART OF THE PROGRAM. A DISPLAY OF 'YES' DIRECTS THE USER TO INCREASE THE SECTION UNDER REVIEW AS THE RECOMMENDATIONS OF THE PCI DESIGN HANDBOOK ARE NOT SATISFIED.

THETA/ACTUAL

IF THE DISPLAY IN THE ABOVE ROW IS '\*NO' THEN THE VALUE OF  $\theta$  IS REVISED TO EQUAL  $\theta_{MAX}$  AS DESCRIBED IN THE ABOVE PARAGRAPH. IF HOWEVER THE DISPLAY IN THE ABOVE ROW IS 'NO\*' THEN THE VALUE FOR  $\theta$  REMAINS EQUAL TO  $\theta_{AVERAGE}$ .

$$= \theta_{MAX} = 80 - (122.58 * (t_n / f'c)); \theta_{AVERAGE} = (\theta_{MIN} + \theta_{MAX}) / 2.$$

ao(in)

EQUIVALENT DEPTH OF COMPRESSION IN TORSION.

$$= \text{SEE EQUATION (4.4.14) OF THE THIRD EDITION OF THE PCI DESIGN HANDBOOK.}$$

Ao(in<sup>2</sup>)

AREA ENCLOSED BY SHEAR FLOW PATH.

$$= \text{SEE EQUATION (4.4.15) OF THE PCI DESIGN HANDBOOK.}$$

At(in<sup>2</sup>/ft)

AREA OF ONE LEG OF CLOSED STIRRUP; INCHES<sup>2</sup> PER FOOT OF BEAM SPAN REQUIRED AT LOCATION UNDER INVESTIGATION. IF THE DISPLAY IN THE '\* $T_u$  REINF. REQ'D' ROW WITHIN THE SAME SPAN LOCATION COLUMN UNDER REVIEW IS 'NO' THEN THE PROGRAM IS PROMPTED TO DISPLAY 'N/R' INDICATING NO TORSIONAL REINFORCEMENT IS REQUIRED. THE USER SHOULD RETURN TO THE ULTIMATE BEAM SHEAR ANALYSIS PORTION OF THE SPREAD SHEET PROGRAM TO SIZE THE APPROPRIATE SHEAR REINFORCEMENT REQUIRED. A DISPLAY OF 'YES' IN THE REFERENCED '\* $T_u$  REINF. REQ'D' ROW WILL RESULT IN THE PROGRAM CALCULATING THE APPROPRIATE AMOUNT OF TORSIONAL REINFORCING REQUIRED.

= SEE EQUATION (4.4.16) OF THE PCI DESIGN HANDBOOK.

Av(in<sup>2</sup>/ft)

AREA OF SHEAR REINFORCEMENT; INCHES<sup>2</sup> PER FOOT OF BEAM SPAN REQUIRED AT THE LOCATION UNDER INVESTIGATION. AS INDICATED ABOVE, IF NO TORSIONAL REINFORCEMENT IS REQUIRED AS DETERMINED BY CALCULATIONS THEN THE PROGRAM PROMPTS A '\*' DISPLAY WHICH IN TURN REFERS TO THE DISPLAY AT THE FAR RIGHT OF THIS ROW INDICATING TO '(SEE ABOVE)'. THIS DIRECTS THE USER TO RETURN TO THE ULTIMATE BEAM SHEAR ANALYSIS PORTION OF THE PROGRAM. IF TORSIONAL REINFORCEMENT IS REQUIRED THEN THE APPROPRIATE AMOUNT OF SHEAR REINFORCING REQUIRED IS DISPLAYED.

= SEE EQUATION (4.4.17) OF THE PCI DESIGN HANDBOOK.

Av+2At(in<sup>2</sup>/ft)

FOR PRESTRESSED MEMBERS WITH AN EFFECTIVE PRESTRESS FORCE NOT LESS THAN 40% OF THE TENSILE STRENGTH OF THE FLEXURAL REINFORCEMENT, A MINIMUM AREA OF SHEAR REINFORCEMENT SHALL BE PROVIDED AS PER ACI 318-83 (11.5.5.4).

= SEE EQUATION (11-15) OF ACI 318-83. SPACING ASSUMED IN THIS EQUATION EQUALS 12 INCHES THEREFORE THE VALUE DISPLAYED IS IN INCHES<sup>2</sup> PER FOOT OF BEAM AT THE SPAN LOCATION UNDER REVIEW.

BAR AREA

BASED ON THE STANDARD ASTM REINFORCING BAR SIZE INPUT THE PROGRAM DISPLAYS THE APPROPRIATE CROSS-SECTIONAL AREA OF ONE BAR (in<sup>2</sup>).

= .11 FOR #3, .20 FOR #4, .31 FOR #5 AND .44 FOR #6 BAR.

REQ'D SPACING

BASED ON THE REQUIREMENTS OF SECTION 4.4.2 OF THE THIRD EDITION OF THE PCI DESIGN HANDBOOK THE PROGRAM CALCULATES THE REQUIRED SPACING OF THE STIRRUP SIZE AND TYPE INPUT BY THE USER. IF NO TORSIONAL REINFORCEMENT IS REQUIRED AS CALCULATED BY THE PROGRAM THEN THE DISPLAY VALUE IS '0'.

= THE PROGRAM CALCULATES THE SPACING REQUIRED BASED ON THE STIRRUP SIZE AND TYPE INPUT TO SATISFY TORSIONAL AND SHEAR REINFORCING REQUIREMENTS ESTABLISHED BY THE PROGRAM. STIRRUP SPACING IS ALSO CALCULATED BASED ON MINIMUM AND MAXIMUM ACI CODE SPECIFICATIONS AND PCI DESIGN HANDBOOK RECOMMENDATIONS. FROM THIS CRITERIA THE PROGRAM PROMPTS THE DISPLAY OF THE SMALLEST VALUE IN INCHES.

DELTA Nu(kips)

EQUIVALENT FACTORED AXIAL LOAD CAUSED BY SHEAR AND TORSION.

= SEE EQUATION (4.4.19) OF THE PCI DESIGN HANDBOOK.

MIN Mn(KF)

NOMINAL MOMENT STRENGTH OF SECTION IN KIP-FEET.

= SEE EQUATIONS (4.4.20), (4.4.21) AND (4.4.23) OF THE THIRD EDITION OF THE PCI DESIGN HANDBOOK.

LONG.REINF.REQ'D

THE TOTAL AMOUNT OF LONGITUDINAL REINFORCEMENT PROVIDED IN A BEAM TYPICALLY INCLUDES SIDE BARS IN EACH FACE OF THE BEAM AND ALL TOP AND BOTTOM FLEXURAL REINFORCEMENT. THE INTENT OF THIS PORTION OF THE PROGRAM IS TO DETERMINE THE CAPACITY OF THE LONGITUDINAL REINFORCEMENT INPUT TO RESIST ALL APPLIED MOMENTS AND AXIAL TENSION CAUSED BY THE SHEAR AND TORSION AT THE SPAN LOCATION UNDER INVESTIGATION. THIS CAPACITY IS CALCULATED BASED ONLY ON THE TOTAL AMOUNT OF FLEXURAL REINFORCEMENT INPUT BY THE USER. IF THE CAPACITY OF THE SECTION AS REINFORCED IS ADEQUATE THEN THE PROGRAM PROMPTS A DISPLAY OF 'NO' INDICATING NO INCREASE IN THE MAIN FLEXURAL REINFORCEMENT IS REQUIRED TO SATISFY THE REQUIREMENTS OF THE PCI DESIGN GUIDELINES. HOWEVER A MINIMUM AMOUNT OF SIDE BARS SHOULD BE PROVIDED IN THE SECTION UNDER REVIEW SPACED AT A MAXIMUM OF 12 INCHES VERTICALLY IN ORDER TO HELP CONTROL DIAGONAL CRACKING OF THE BEAM IN QUESTION. THE PROGRAM DOES NOT QUANTIFY THE AMOUNT OF SIDE BARS REQUIRED IN THIS SITUATION. THE DESIGNER SHOULD USE HIS OR HER OWN DISCRETION IN SPECIFYING SUCH REINFORCEMENT. IF THE CAPACITY OF THE SECTION AS REINFORCED IS INADEQUATE THEN THE PROGRAM PROMPTS A DISPLAY OF 'YES\*' INDICATING ADDITIONAL FLEXURAL REINFORCEMENT AND OR LONGITUDINAL SIDE BARS ARE REQUIRED. THE ASTERISK REFERS TO THE DISPLAY AT THE FAR RIGHT OF THE SAME ROW WHICH INDICATES THAT  $MINMn > (\Phi Mn / .90)$ . AGAIN THE PROGRAM DOES NOT QUANTIFY THE AMOUNT OF SUPPLEMENTAL LONGITUDINAL REINFORCING REQUIRED IN THIS SITUATION. HOWEVER, THE DESIGNER IS DIRECTED BY THIS DISPLAY TO REITERATE THE SPREAD SHEET INPUT WITH AN INCREASED AMOUNT OF POST-TENSIONING STRAND AND OR BONDED REINFORCING BARS.

= SEE EQUATIONS (4.4.20, 21 AND 23) OF THE PCI DESIGN HANDBOOK FOR VALUES OF  $MINMn$ .  $\Phi Mn$  IS AN OUTPUT VALUE DESCRIBED ABOVE.

.....

OPERATING INSTRUCTIONS AND HARDWARE REQUIREMENTS  
.....

THIS PROGRAM WAS ORIGINALLY WRITTEN FOR USE WITH THE 20/20 INTEGRATED SPREAD-SHEET MODELING PROGRAM, RELEASE 2 FOR DEC VAX AND MICROVAX COMPUTERS. THE PROGRAM HAS BEEN CONVERTED FOR USE WITH A LOTUS 1-2-3 TYPE SPREADSHEET FOR SUBMITTAL IN THE 1990 CRSI SOFTWARE DEVELOPMENT COMPETITION.

DATA ENTRY REQUIREMENTS ARE DESCRIBED IN THE DESCRIPTION OF INPUT PARAMETERS.

THE CELL ADDRESS RANGE REQUIREMENTS FOR THE PROPER HARDCOPY REPRODUCTION OF THE MAJOR DESIGN SCREENS ARE AS FOLLOWS;

POST-TENSION SERVICE STRESS	A0..I20
UNBONDED ULTIMATE STRENGTH	A21..I41
ULTIMATE BEAM SHEAR ANALYSIS	A42..I62
ULTIMATE BEAM SHEAR/TORSION ANALYSIS	A63..J114

LIST OF VARIABLES AND DEFINITIONS

.....

- Ac (in<sup>2</sup>) THE AREA ENCLOSED BY THE OUTSIDE PERIMETER OF THE CONCRETE CROSS SECTION, INCLUDING ANY ENCLOSED VOIDS, AS DEFINED BY Pc.
- Ag (in<sup>2</sup>) THE TOTAL CROSS-SECTIONAL AREA OF CONCRETE NOT INCLUDING ANY ENCLOSED VOIDS. FOR BEAM SECTIONS, THIS INCLUDES ANY SLAB LOCATED ON EITHER SIDE OF THE WEB WITH RESPECT TO ONE-HALF THE CLEAR DISTANCE TO THE NEXT ADJACENT BEAM.
- Ao (in<sup>2</sup>) THE AREA ENCLOSED BY THE SHEAR FLOW PATH.
- ao (in) THE EQUIVALENT DEPTH OF COMPRESSION IN TORSION.
- Aoh (in<sup>2</sup>) THE AREA ENCLOSED BY THE OUTSIDE PERIMETER FORMED BY THE CENTERLINE OF A CLOSED STIRRUP.
- Aps (in<sup>2</sup>) THE CROSS-SECTIONAL AREA OF ONE POST-TENSIONING STRAND.
- As (in<sup>2</sup>) THE CROSS-SECTIONAL AREA OF CONVENTIONAL BONDED TENSION REINFORCEMENT.
- Asreq'd (in<sup>2</sup>) THE CROSS-SECTIONAL AREA OF CONVENTIONAL BONDED AUXILIARY TENSION REINFORCEMENT LOCATED IN THE COMPRESSION FACE OF THE MEMBER .
- At (in<sup>2</sup>/ft) THE CROSS-SECTIONAL AREA OF ONE LEG OF A CLOSED STIRRUP REQUIRED PER FOOT OF BEAM SPAN.
- Av (in<sup>2</sup>/ft) THE CROSS-SECTIONAL AREA OF SHEAR REINFORCEMENT REQUIRED PER FOOT OF BEAM SPAN.
- AvMIN (in<sup>2</sup>) THE CROSS-SECTIONAL AREA OF THE MINIMUM SHEAR REINFORCEMENT REQUIRED AT THE "REQ'D SPCG" CALCULATED BY THE PROGRAM TO SATISFY ACI 318-83 (11.5.5.4).
- bf (in) THE WIDTH OF THE EFFECTIVE T-BEAM FLANGE FOR SUCH SECTIONS ,THE WEB WIDTH FOR RECTANGULAR BEAM SECTIONS OR THE DESIGN TOP WIDTH FOR SLAB SECTIONS.
- bv (in) THE MINIMUM EFFECTIVE WEB WIDTH WITHIN DEPTH dv ASSUMING SPALLING OF THE UNRESTRAINED CONCRETE COVER AS SHOWN IN Fig. 4.4.1 OF THE THIRD EDITION OF THE PCI DESIGN HANDBOOK.
- bw (in) THE WEB WIDTH FOR BEAM SECTIONS OR THE DESIGN SOFFIT WIDTH FOR SLAB SECTIONS.
- d (in) THE DISTANCE FROM THE EXTREME FIBER IN COMPRESSION TO THE CENTROID OF THE CONVENTIONAL BONDED TENSION REINFORCEMENT.
- DeltaNu (kips) THE EQUIVALENT FACTORED AXIAL LOAD CAUSED BY SHEAR AND TORSION.
- dp (in) THE DISTANCE FROM THE EXTREME FIBER IN COMPRESSION TO

THE CENTROID OF THE POST-TENSIONING REINFORCEMENT.

dv (in) THE EFFECTIVE SHEAR DEPTH EQUAL TO THE VERTICAL DISTANCE BETWEEN THE CENTERS OF THE LONGITUDINAL BARS LOCATED IN THE CORNERS OF THE CLOSED STIRRUPS.

e (in) THE DISTANCE OR ECCENTRICITY BETWEEN THE CENTROIDAL AXIS OF THE MEMBER AND THE CENTROID OF THE POST-TENSIONING STRAND.

fa(P/A) (psi) THE EFFECTIVE COMPRESSIVE STRESS OF THE SECTION DUE TO THE AXIAL LOADING THAT RESULTS FROM THE POST-TENSION COMPRESSION FORCE.

fb (psi) THE NET SERVICE STRESS AT THE EXTREME BOTTOM FIBER OF THE SECTION DUE TO FLEXURAL BENDING AND AXIAL LOADING AS A RESULT OF GRAVITY AND BALANCING LOADS AND POST-TENSION COMPRESSION FORCE, P/A.

f'c (psi) THE SPECIFIED 28-DAY COMPRESSIVE STRENGTH OF CONCRETE.

f'ci (psi) THE COMPRESSIVE STRENGTH OF CONCRETE AT THE TIME OF INITIAL POST-TENSION STRESS TRANSFER.

f'cimin (psi) THE MINIMUM f'ci REQUIRED WHEN THE COMPUTED INITIAL COMPRESSIVE STRESS EXCEEDS THE ALLOWABLE.

f/comp. (psi) THE MAXIMUM COMPRESSIVE STRESS SPECIFIED BY ACI 318-83 (18.4.2(a)) AT SERVICE LOADS AND (18.4.1(a)) AT TIME OF INITIAL POST-TENSION STRESS TRANSFER.

fps (ksi) THE STRESS IN THE POST-TENSIONING REINFORCEMENT AT NOMINAL STRENGTH.

fse (ksi) THE EFFECTIVE STRESS IN THE POST-TENSIONING REINFORCEMENT AFTER ALLOWANCE FOR ALL LOSSES.

ft (psi) THE NET SERVICE STRESS AT THE EXTREME TOP FIBER OF THE SECTION DUE TO FLEXURAL BENDING AND AXIAL LOADING AS A RESULT OF GRAVITY AND BALANCING LOADS AND POST-TENSION COMPRESSION FORCE, P/A.

f/tension (psi) THE MAXIMUM TENSILE STRESS SPECIFIED BY ACI 318-83 (18.4.1(b)) AT TIME OF INITIAL POST-TENSION STRESS TRANSFER. THE TENSILE STRESS EQUAL TO THE RUPTURE MODULUS OF THE SPECIFIED CONCRETE STRENGTH AT SERVICE LOADS.

fy (ksi) THE YIELD STRENGTH ASSUMED BY THE PROGRAM FOR ALL CONVENTIONAL BONDED REINFORCEMENT INCLUDING AUXILIARY TENSILE BARS AND FLEXURAL AND SHEAR REINFORCEMENT; 60 ksi.

h (in) THE TOTAL DEPTH OR THICKNESS OF THE DESIGN MEMBER.

hf (in) THE THICKNESS OF THE FLANGE OR SLAB PORTION OF A T-BEAM SECTION.

Mb (KF) THE BALANCING LOAD MOMENT IN KIP-FEET.

MinMn (KF) THE NOMINAL MOMENT STRENGTH IN KIP-FEET AT WHICH SUPPLEMENTAL LONGITUDINAL REINFORCEMENT IS REQUIRED.

Mocr (KF) THE PURE FLEXURAL CRACKING STRENGTH IN KIP-FEET OF THE DESIGN MEMBER.

Ms (KF) THE TOTAL SERVICE OR UNFACTORED MOMENT IN KIP-FEET OF THE DESIGN MEMBER.

MsDLi (KF) THE INITIAL SERVICE OR UNFACTORED DEAD LOAD PORTION OF Ms IN KIP-FEET.

Mu (KF) THE TOTAL FACTORED OR ULTIMATE MOMENT IN KIP-FEET OF THE DESIGN MEMBER.

Pc (in) THE OUTSIDE PERIMETER OF THE CONCRETE CROSS SECTION AS DEFINED IN ACI 318-83 (11.6.1).

ph (in) THE PERIMETER OF A CLOSED STIRRUP AS DEFINED BY THE CENTERLINE OF THE REINFORCING BAR.

PhiMn (KF) THE FACTORED ULTIMATE MOMENT STRENGTH CAPACITY IN KIP-FEET OF THE DESIGN MEMBER.

PhiVn (K) THE FACTORED ULTIMATE SHEAR STRENGTH CAPACITY IN KIPS OF THE DESIGN MEMBER.

Pps THE RATIO OF THE POST-TENSION REINFORCEMENT;  $A_{ps}/(b \cdot d_p)$ .

P/T (kips) THE EFFECTIVE POST-TENSIONING FORCE PER STRAND.

Sb (in<sup>3</sup>) THE SECTION MODULUS WITH RESPECT TO THE BOTTOM OF THE DESIGN MEMBER.

St (in<sup>3</sup>) THE SECTION MODULUS WITH RESPECT TO THE TOP OF THE DESIGN MEMBER.

THETA THE ANGLE OF INCLINATION TO THE LONGITUDINAL AXIS OF THE MEMBER IN DEGREES OF THE DIAGONAL COMPRESSION STRESS.

tn (ksi) THE NOMINAL SHEAR STRESS OF THE DESIGN MEMBER.

Tocr (KF) THE PURE TORSIONAL CRACKING STRENGTH IN KIP-FEET OF THE DESIGN MEMBER.

Tu (KF) THE TOTAL FACTORED OR ULTIMATE TORSIONAL MOMENT IN KIP- FEET OF THE DESIGN MEMBER.

Vc (kips) THE NOMINAL SHEAR STRENGTH PROVIDED BY THE CONCRETE SECTION.

VcMAX (kips) THE MAXIMUM NOMINAL SHEAR STRENGTH OF THE CONCRETE SECTION AS PER ACI 318-83 (11.4.1).

VcMIN (kips) THE MINIMUM NOMINAL SHEAR STRENGTH OF THE CONCRETE SECTION AS PER ACI 318-83 (11.4.1)

Vocr (kips) THE PURE SHEAR CRACKING STRENGTH OF THE DESIGN MEMBER.

Vp (kips) THE VERTICAL COMPONENT OF THE EFFECTIVE POST-TENSIONING FORCE.

Vs (kips) THE NOMINAL SHEAR STRENGTH PROVIDED BY SHEAR REINFORCEMENT.

Vu (kips) THE TOTAL FACTORED OR ULTIMATE SHEAR ON THE DESIGN MEMBER.

w THE RATIO OF CONVENTIONAL BONDED REINFORCEMENT,  $A_s/(b*d)$ , MULTIPLIED BY THE RATIO  $f_y/f'_c$ .

wp THE RATIO OF POST-TENSIONING REINFORCEMENT,  $P_{ps}$ , MULTIPLIED BY THE RATIO  $f_{ps}/f'_c$ .

yb (in) THE DISTANCE FROM THE CENTROIDAL AXIS OF THE MEMBER TO THE EXTREME BOTTOM FIBER OF THE SECTION.

yt (in) THE DISTANCE FROM THE CENTROIDAL AXIS OF THE MEMBER TO THE EXTREME TOP FIBER OF THE SECTION.

DESIGN EXAMPLE

- DESIGN ASSUMPTIONS:
- ONE-STORY BRACED PARKING GARAGE STRUCTURE.  
NO LATERAL LOADS.
  - LIVE LOAD = 50 PSF.
  - REGULAR WEIGHT CONCRETE;  $f'c = 4000$  psi.
  - POST-TENSION REINFORCEMENT; 1/2"-270K LO-LAX STRAND.
  - DESIGN TYPICAL 18"x30" BEAM AND 48"x30" TRANSFER BEAM.

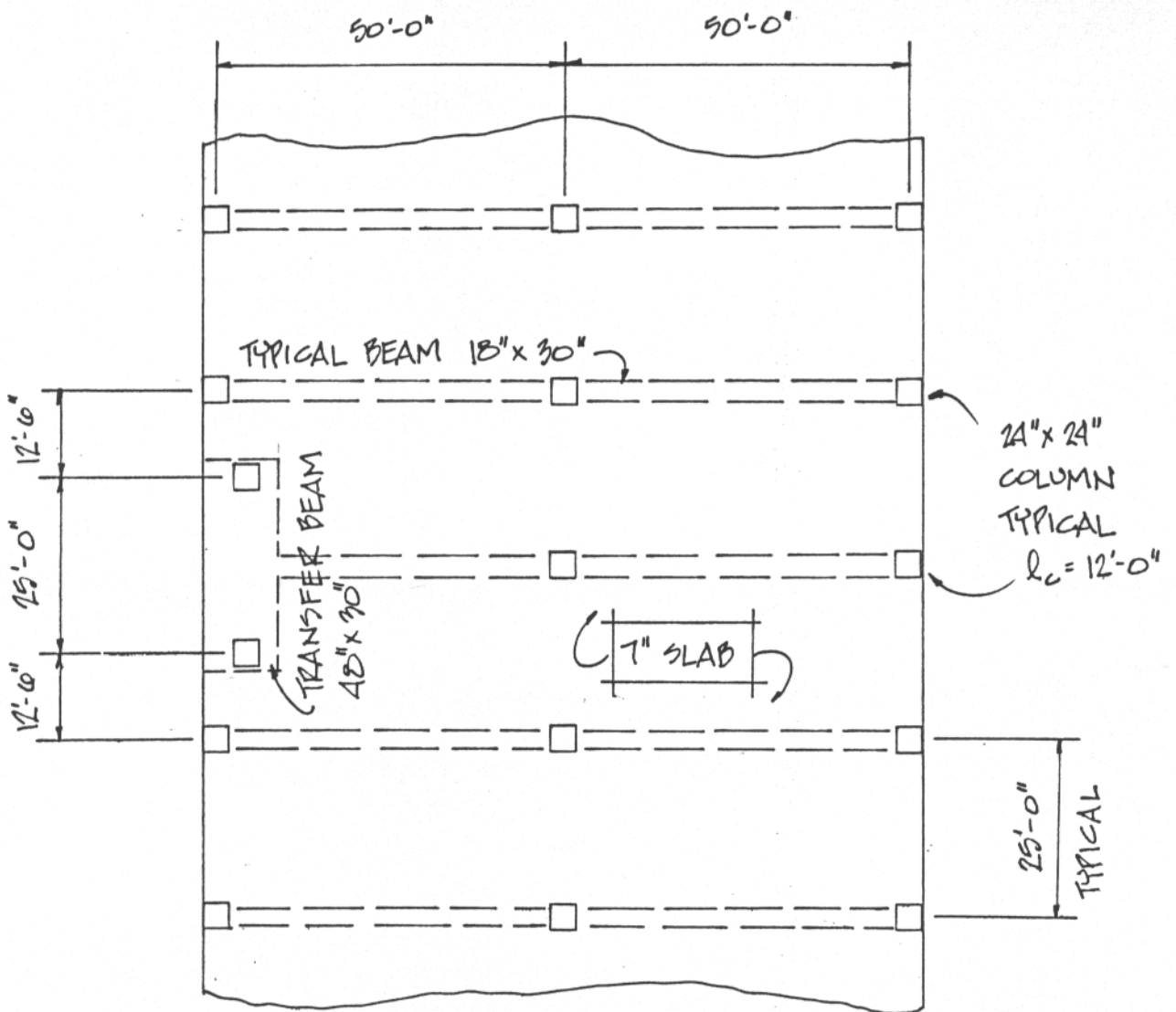

PLAN VIEW

DESIGN EXAMPLE

TYPICAL BEAM 18"x30"

SECTION PROPERTIES:

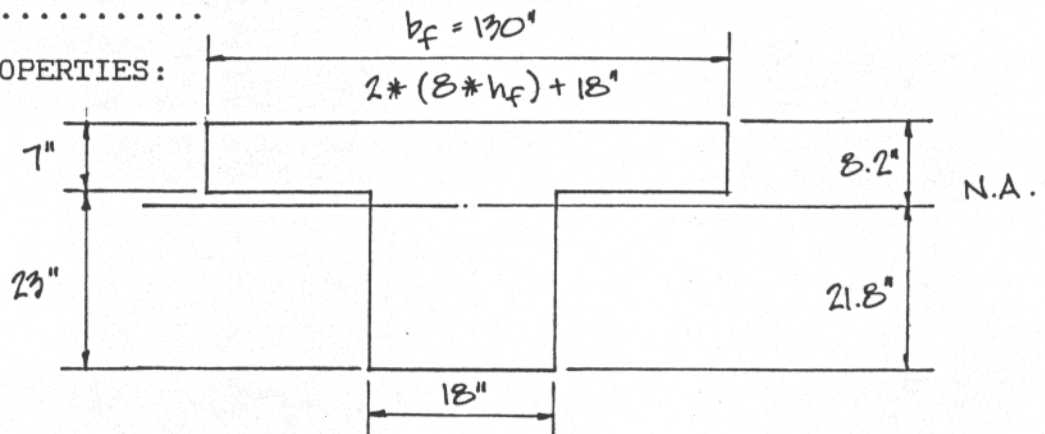

$$y_b = ((130 \times 7 \times 26.5) + (23 \times 18 \times 11.5)) / (910 + 414) = 21.8"; \quad y_t = 8.2"$$

$$I_g = [((130 \times (7)^3) / 12) + (910 \times (4.7)^2)] + [((18 \times (23)^3) / 12) + (414 \times (10.3)^2)] = 85989.5 \text{ in}^4$$

$$S_b = 3944.5 \text{ in}^3; \quad S_t = 10486.5 \text{ in}^3$$

$$A_g = (25 \times 12 \times 7) + (23 \times 18) = 2514 \text{ in}^2$$

STRAND DRAPE/BEAM DIAGRAM:

COVER REQUIRED = CODE MINIMUM + #4 STIRRUP DIAMETER + ONE-HALF STRAND DIAMETER.

$$= 1.5 + .5 + .25 = 2.25"$$

(USE 2.5" FOR BONDED REINFORCEMENT)

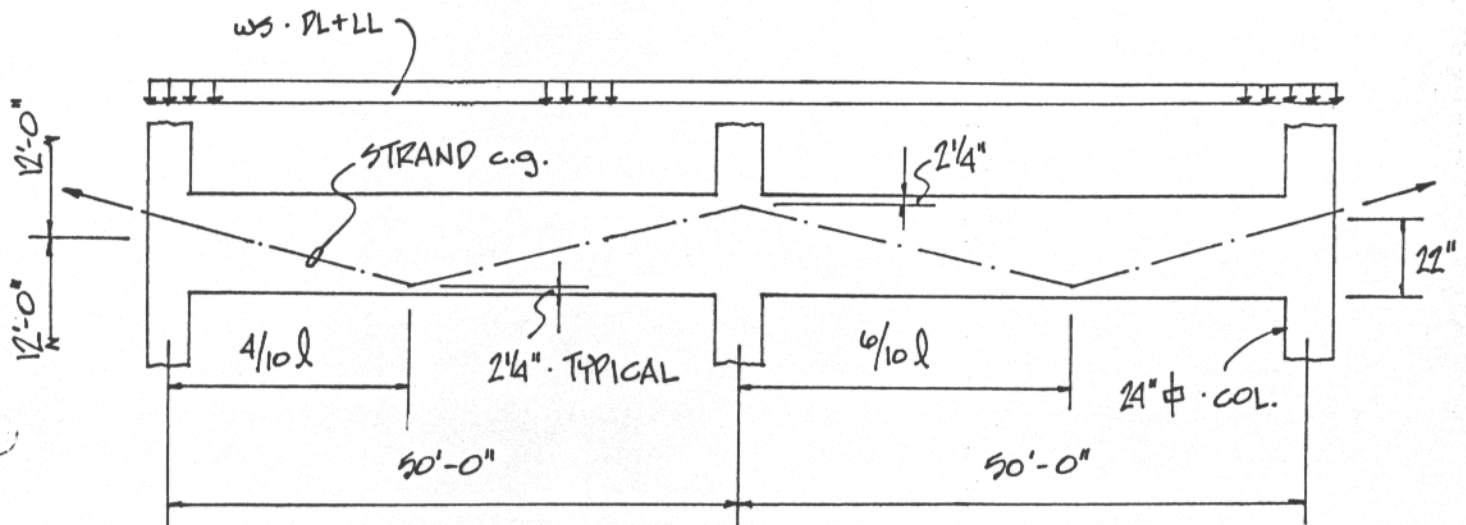



-----  
 TYPICAL BEAM 18"x 30"/CRSI DESIGN EXAMPLE

JACKING FROM EACH END; SPANS NUMBERED RIGHT TO LEFT

NUMBER OF SPANS = 2  
 LEFT CANTILEVER NO  
 RIGHT CANTILEVER NO  
 STRAND SIZE = 1/2inch  
 fpu = 270 ksi  
 Aps = .153 in<sup>2</sup>  
 E = 28500 ksi  
 WEDGE SET = .25 inch  
 FRICTION COEFFICIENT(u) = .07  
 WOBBLE FACTOR(k) = .0014  
 LOW-LAX STRAND YES  
 STRESS-RELIEVED STRAND NO  
 SLAB SECTION NO  
 BEAM OR JOIST SECTION YES

SPAN	LENGTH (ft)	LEFT SUPPORT ECC.(inch)	MIDSPAN ECC.(in.)	RIGHT SUPPORT ECC.(inch)
1	50	0	-19.75	5.75
2	50	5.75	-19.75	0

JACKING FORCE= .8 fpuAps = 33.048 kips  
 ANCHOR SET LOSS = 4.69823 kips  
 LIVE END ANCHORED FORCE = 28.3498 kips  
 MAXIMUM LE ANCHORAGE FORCE=.70fpuAps = 28.917 kips  
 LENGTH OF STRAND INFLUENCED BY ANCHOR SET= 38.6714 ft.  
 DEAD END ANCHORED FORCE = 26.9734 kips  
 TOTAL ANGULAR CHANGE = .895833 radians

LONGTERM LOSSES= 3.06 kips

BALANCING LOADS

SPAN	h(inch)	P/T(kips) (AVE.NET)	wb(klf)
1	22.625	28.45	.171
2	22.625	28.45	.171

STRAND LOCATION  
(PARABOLIC DRAPE)

[AS MEASURED FROM N.A.:+ ABOVE/- BELOW (inches)]

SPAN NO#	FACE OF LEFT SUPPORT	h/2 FROM FOS	2/10	3/10	4/10	5/10
----------	----------------------	--------------	------	------	------	------

1	-1.93	-4.20	-14.82	-18.52	-19.75	-18.66
2	5.64	5.23	-2.26	-9.91	-15.38	-18.66

SPAN NO#	6/10	7/10	8/10	h/2 FROM FOS	FACE OF RIGHT SUPPORT
----------	------	------	------	--------------	-----------------------

1	-15.38	-9.91	-2.26	5.23	5.64
2	-19.75	-18.52	-14.82	-4.20	-1.93

## DESIGN EXAMPLE

## ONE-STORY FRAME ANALYSIS:

TYPICAL BEAM/CRSI *w<sub>g</sub> · D+LL*

E= 3605 KSI

SPAN	LENGTH	INERTIA
1	50	85989.5
2	50	85989.5

JOINT NO.	LENGTH ft.	INERTIA in <sup>4</sup>
ALL	12	27648
ALL	12	27648

+I=FIXED -I=PINNED

## LOAD OPTIONS

- 1=UNIFORM LOAD (5)  
 2=CONCENTRATED LOAD (12)  
 3=TRIANGULAR LOAD (5)  
 4=CONCENTRATED MOMENT(5)  
 5=DUPLICATE LOADS  
 6=END LOADING

( ) INDICATES THE MAX. NO. OF LOADS(D+L)PER SPAN

LOAD	BEGIN	ENDS
K/K/FT	FT	FT
SPAN: 1		
W	3.37	0.00 50.00
SPAN: 2		
W	3.37	0.00 50.00

JOINT 0  
 COLUMN ABOVE 255.63 kft  
 COLUMN BELOW 255.63 kft  
 CLOCKWISE +

## SPAN 1

X	SHEAR	MOMENT
0.00	78.53	-511.27
5.00	61.68	-160.77
10.00	44.83	105.49
15.00	27.98	287.49
20.00	11.13	385.24
25.00	-5.72	398.74
30.00	-22.57	328.00
35.00	-39.42	173.00
40.00	-56.27	-66.25
45.00	-73.12	-389.75
50.00	-89.97	-797.49

INFLECTION POINTS:  
 0.02 ft 38.62 ft  
 MAX. DEFLECTION=  
 0.389 in +↓

JOINT 1  
 COLUMN ABOVE -0.00 kft  
 COLUMN BELOW -0.00 kft

## SPAN 2

X	SHEAR	MOMENT
0.00	89.97	-797.49
5.00	73.12	-389.75
10.00	56.27	-66.25
15.00	39.42	173.00
20.00	22.57	328.00
25.00	5.72	398.74
30.00	-11.13	385.24
35.00	-27.98	287.48
40.00	-44.83	105.48
45.00	-61.68	-160.77
50.00	-78.53	-511.27

INFLECTION POINTS:  
 11.38 ft 41.98 ft  
 MAX. DEFLECTION=  
 0.389 in +↓

JOINT 2  
 COLUMN ABOVE -255.64 kft  
 COLUMN BELOW -255.64 kft

TYPICAL BEAM/CRSI *w<sub>g</sub>*

E= 3605 KSI

SPAN	LENGTH	INERTIA
1	50	85989.5
2	50	85989.5

JOINT NO.	LENGTH ft.	INERTIA in <sup>4</sup>
ALL	12	27648
ALL	12	27648

+I=FIXED -I=PINNED

## LOAD OPTIONS

- 1=UNIFORM LOAD (5)  
 2=CONCENTRATED LOAD (12)  
 3=TRIANGULAR LOAD (5)  
 4=CONCENTRATED MOMENT(5)  
 5=DUPLICATE LOADS  
 6=END LOADING

( ) INDICATES THE MAX. NO. OF LOADS(D+L)PER SPAN

LOAD	BEGIN	ENDS
K/K/FT	FT	FT
SPAN: 1		
W	-0.17	0.00 50.00
SPAN: 2		
W	-0.17	0.00 50.00

JOINT 0  
 COLUMN ABOVE -12.97 kft  
 COLUMN BELOW -12.97 kft  
 CLOCKWISE +

## SPAN 1

X	SHEAR	MOMENT
0.00	-3.98	25.94
5.00	-3.13	8.16
10.00	-2.27	-5.35
15.00	-1.42	-14.59
20.00	-0.56	-19.55
25.00	0.29	-20.23
30.00	1.15	-16.64
35.00	2.00	-8.78
40.00	2.86	3.36
45.00	3.71	19.78
50.00	4.57	40.47

INFLECTION POINTS:  
 38.62 ft 8.02 ft  
 MAX. DEFLECTION=  
 -0.020 in +↓

JOINT 1  
 COLUMN ABOVE 0.00 kft  
 COLUMN BELOW 0.00 kft

## SPAN 2

X	SHEAR	MOMENT
0.00	-4.57	40.47
5.00	-3.71	19.78
10.00	-2.86	3.36
15.00	-2.00	-8.78
20.00	-1.15	-16.64
25.00	-0.29	-20.23
30.00	0.56	-19.55
35.00	1.42	-14.59
40.00	2.27	-5.35
45.00	3.13	8.16
50.00	3.98	25.94

INFLECTION POINTS:  
 41.98 ft 11.38 ft  
 MAX. DEFLECTION=  
 -0.020 in +↓

JOINT 2  
 COLUMN ABOVE 12.97 kft  
 COLUMN BELOW 12.97 kft

POST-TENSION SERVICE STRESS

SHEET NO# 7

REFERENCE CODE: TYP. BM. 18"X30"/MAX POSITIVE MOMENT/CRSI

SPAN (ft)=	50	h (in) =	30
Sb (in3) =	3944.5	yb (in) =	21.8
St (in3) =	10486.5	yt (in) =	8.2
Ag (in2) =	2514		
Ms (KF) =	398.74	MsDLi (KF)=	309.82
f'c(psi) =	4000	f'ci(psi) =	2400

FOR 1 STRAND:

Mb (KF) =	-20.23	INITIAL LOSSES(%)=	3
P/T(kips)=	28.45	LONGTERMLOSSES(K)=	3.06
Aps(in2) =	0.153		

NUMBER OF STRANDS REQ'D = 10.1387 [7.5\*SQRT f'c]  
 DESIRED NO# OF STRANDS = 12 fa(P/A)= 135.8 P/Amin= 125psi

		SERVICE	INITIAL
STRESS AT	fb (psi) =	-338.72	-3.2221
12 STRANDS:	ft (psi) =	314.292	201.983
ALLOWABLE	f/tension (psi)=	-474.34	-146.97
STRESS:	f/comp. (psi) =	1800	1440

UNBONDED ULTIMATE STRENGTH

	ONE-WAY BM/SLAB	TWO-WAY PLATE
NO=0;YES=1	1	0
ULTIMATE LOAD FACTOR	= 1.47	SPAN/DEPTH RATIO = 20
	bw(in) = 18	
	bf(in) = 130	
	dp(in) = 26.66	
	d (in) = 27.5	
	e (in) = 18.66	
	hf (in)= 7	
MINIMUM BONDED	As(in2)= 1.5696	fy(ksi)= 60
DESIRED REINF.	As(in2)= 1.76	w = 0.00738
Pps =	0.00053	wp = 0.03595
fse (ksi)=	185.948	w + wp = 0.04334
fps (ksi)=	271.455	MAX w + wp = 0.306
SECONDARY EFFECT(KF) =	288.117	
Mu (KF) =	874.265	
PhiMn (KF) =	1183.38	ADEQ. REINF. PROVIDED
1.2*Mocr (KF) =	531.982	ADEQ. REINF. PROVIDED

POST-TENSION SERVICE STRESS

SHEET NO# 8

REFERENCE CODE: TYP. BM. 18"X30"/-Ms @ FACE OF INT.SUPPORT/CRSI

SPAN (ft)=	50	h (in) =	30
Sb (in3) =	3944.5	yb (in) =	21.8
St (in3) =	10486.5	yt (in) =	8.2
Ag (in2) =	2514		
Ms (KF) =	-709.21	MsDLi (KF)=	-551.1
f'c(psi) =	4000	f'ci(psi) =	2400
FOR 1 STRAND:			
Mb (KF) =	35.98	INITIAL LOSSES(%)=	3
P/T(kips)=	28.45	LONGTERMLOSSES(K)=	3.06
Aps(in2) =	0.153		
NUMBER OF STRANDS REQ'D =	6.42455 [7.5*SQRT f'c]		
DESIRED NO# OF STRANDS =	12	fa(P/A)=	135.8 P/Amin= 125psi
		SERVICE	INITIAL
STRESS AT fb (psi) =	979.846		411.318
12 STRANDS:ft (psi) =	-181.69		46.0542
ALLOWABLE f/tension (psi)=	-474.34		-146.97
STRESS: f/comp. (psi) =	1800		1440

UNBONDED ULTIMATE STRENGTH

	ONE-WAY BM/SLAB	TWO-WAY PLATE
NO=0;YES=1	1	0
ULTIMATE LOAD FACTOR =	1.47	SPAN/DEPTH RATIO = 20
bw(in) =	18	
bf(in) =	130	
dp(in) =	27.64	
d (in) =	27.5	
e (in) =	5.64	
hf (in)=	7	
MINIMUM BONDED As(in2)=	3.7264	fy(ksi)= 60
DESIRED REINF. As(in2)=	3.96 / 9.#6	w = 0.12
Pps =	0.00369	w <sub>p</sub> = 0.19078
fse (ksi)=	185.948	w + w <sub>p</sub> = 0.31078
fps (ksi)=	206.787	MAX w + w <sub>p</sub> = 0.306
SECONDARY EFFECT(KF) =	271.302	OVERREINFORCED SECTION
Mu (KF)	= -771.23	MAX PhiMn = -1023.9 > -771.23 ✓
PhiMn (KF)	= -1043.6	
1.2*Mocr (KF)	= -1157.9	INCREASE SECTION !

N.A. - SECTION WOULD FAIL AT POSITIVE MOMENT REGION DUE TO OVERLOAD PRIOR TO FAILURE AT SUPPORT. AS SECTION MEETS THIS CRITERIA AT POSITIVE REGION, SAY O.K.

ULTIMATE BEAM SHEAR ANALYSIS

SHEET NO# 9

LOCATION	1	2	3	4	5	6	
DISTANCE	47.75	45	40	35	30	25	
Vu(kips)	121.11	107.49	82.72	57.95	33.18	8.41	
Mu(KF)	-887.27	-572.93	-97.38	254.31	482.16	586.14	
dp(in)	27.23	22	19.74	17.91	23.38	26.66	
Vc(kips)	124.869	120.407	318.793	119.239	56.9376	28.9181	
VcMIN(K)	61.9984	54.6442	54.6442	54.6442	54.6442	60.7006	
VcMAX(K)	154.996	136.61	136.61	136.61	136.61	151.751	
STIRRUPS	REQ'D	REQ'D	MIN	MIN	MIN	N/R	fy
BAR SIZE	4	4	4	4	4	4	60ksi
BAR AREA	0.2	0.2	0.2	0.2	0.2	0.2	
MIN SPCG	22.5	22.5	22.5	22.5	22.5	22.5	
REQ'D SPCG(in)	37.1	95.17	22.5	22.5	22.5	22.5	
AvMIN(in2)	0.17306	0.47288	0.1118	0.1118	0.1118	N/A	(@SPCG)
STIRRUP TYPE	[_]	[_]	[_]	[_]	[_]	[_]	
Vs(kips)	17.6151	6.05233	25.6	25.6	25.6	28.4373	
PhiVn(K)	121.112	107.49	137.879	123.113	70.157	75.7672	

POST-TENSION SERVICE STRESS

SHEET NO# 10

REFERENCE CODE: TYP. BM. 18"X30"/-Ms @ FACE OF EXT.SUPPORT/CRSI

SPAN (ft)=	50	h (in) =	30
Sb (in3) =	3944.5	yb (in) =	21.8
St (in3) =	10486.5	yt (in) =	8.2
Ag (in2) =	2514		
Ms (KF) =	-434.43	MsDLi (KF)=	-337.6
f'c(psi) =	4000	f'ci(psi) =	2400

FOR 1 STRAND:

Mb (KF) =	22.05	INITIAL LOSSES(%)=	3
P/T(kips)=	28.45	LONGTERMLOSSES(K)=	3.06
Aps(in2) =	0.153		

NUMBER OF STRANDS REQ'D = 0.62352 [7.5\*SQRT f'c]

DESIRED NO# OF STRANDS = 12 fa(P/A)= 135.8 P/Amin= 125psi

		SERVICE	INITIAL
STRESS AT fb (psi) =		652.458	308.141
12 STRANDS:ft (psi) =		-58.542	84.864
ALLOWABLE f/tension (psi)=		-474.34	-146.97
STRESS: f/comp. (psi) =		1800	1440

UNBONDED ULTIMATE STRENGTH

	ONE-WAY BM/SLAB	TWO-WAY PLATE
NO=0;YES=1	1	0
ULTIMATE LOAD FACTOR =	1.47	SPAN/DEPTH RATIO = 20
bw(in) =	18	
bf(in) =	130	
dp(in) =	20.07	
d (in) =	27.5	
e (in) =	0	
hf (in)=	7	
MINIMUM BONDED As(in2)=	3.7264	fy(ksi)= 60
DESIRED REINF. As(in2)=	3.96	w = 0.12
Pps =	0.00508	wp = 0.25896
fse (ksi)=	185.948	w + wp = 0.37896
fps (ksi)=	203.818	MAX w + wp = 0.306
SECONDARY EFFECT(KF) =	264.6	OVERREINFORCED SECTION
Mu (KF) =	-374.01	MAX PhiMn = -539.87 > -374.01 ✓
PhiMn (KF) =	-823.97	
1.2*Mocr (KF) =	-957.34	ADEQ. REINF. PROVIDED

ULTIMATE BEAM SHEAR ANALYSIS

SHEET NO# 11

LOCATION	1	2	3	4	5	6	
DISTANCE	2.25	5	10	15	20	25	
Vu(kips)	104.3	90.67	65.9	41.13	16.36	8.41	
Mu(KF)	-504.37	-236.33	155.1	422.61	566.3	586.14	
dp(in)	17.8	12.49	22.82	26.52	27.75	26.66	
Vc(kips)	109.152	137.149	260.731	89.9858	42.3136	28.9181	
VcMIN(K)	54.6442	54.6442	54.6442	60.3818	63.1823	60.7006	
VcMAX(K)	136.61	136.61	136.61	150.954	157.956	151.751	
STIRRUPS	REQ'D	MIN	MIN	MIN	N/R	N/R	fy
BAR SIZE	4	4	4	4	4	4	60ksi
BAR AREA	0.2	0.2	0.2	0.2	0.2	0.2	
MIN SPCG	22.5	22.5	22.5	22.5	22.5	22.5	
REQ'D SPCG(in)	42.5	22.5	22.5	22.5	22.5	22.5	
AvMIN(in <sup>2</sup> )	0.21117	0.1118	0.1118	0.10635	N/A	N/A	(@SPCG)
STIRRUP TYPE	[_]	[_]	[_]	[_]	[_]	[_]	
Vs(kips)	13.5529	25.6	25.6	28.288	29.6	28.4373	
PhiVn(K)	104.299	137.879	137.879	100.533	78.865	75.7672	

DESIGN EXAMPLE

TRANSFER BEAM 48"x30"

SECTION PROPERTIES:

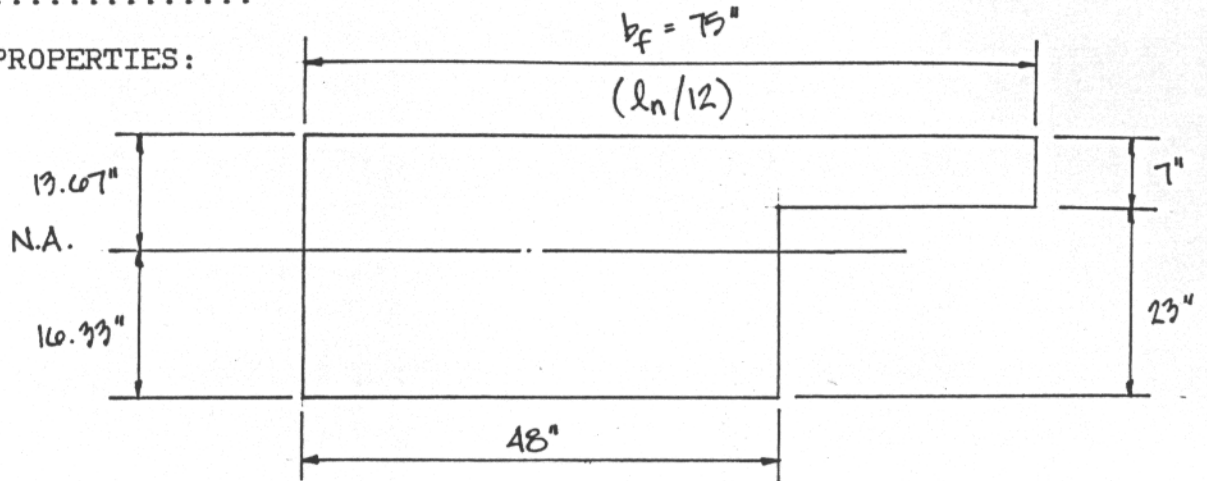

$$y_b = ((75 \times 7 \times 26.5) + (48 \times 23 \times 11.5)) / (525 + 1104) = 16.33; \quad y_t = 13.67$$

$$I_g = [((75 \times (7)^3) / 12) + (525 \times (10.17)^2)] + [((48 \times (23)^3) / 12) + (1104 \times (2.17)^2)] = 110310.5 \text{ in}^4$$

$$S_b = 6755.1 \text{ in}^3; \quad S_t = 8069.5 \text{ in}^3$$

THE 7" SLAB IS POST-TENSIONED PARALLEL TO THIS BEAM THEREFORE;  $A_g = (525 + 1104) = 1629 \text{ in}^2$ .

STRAND DRAPE/BEAM DIAGRAM:

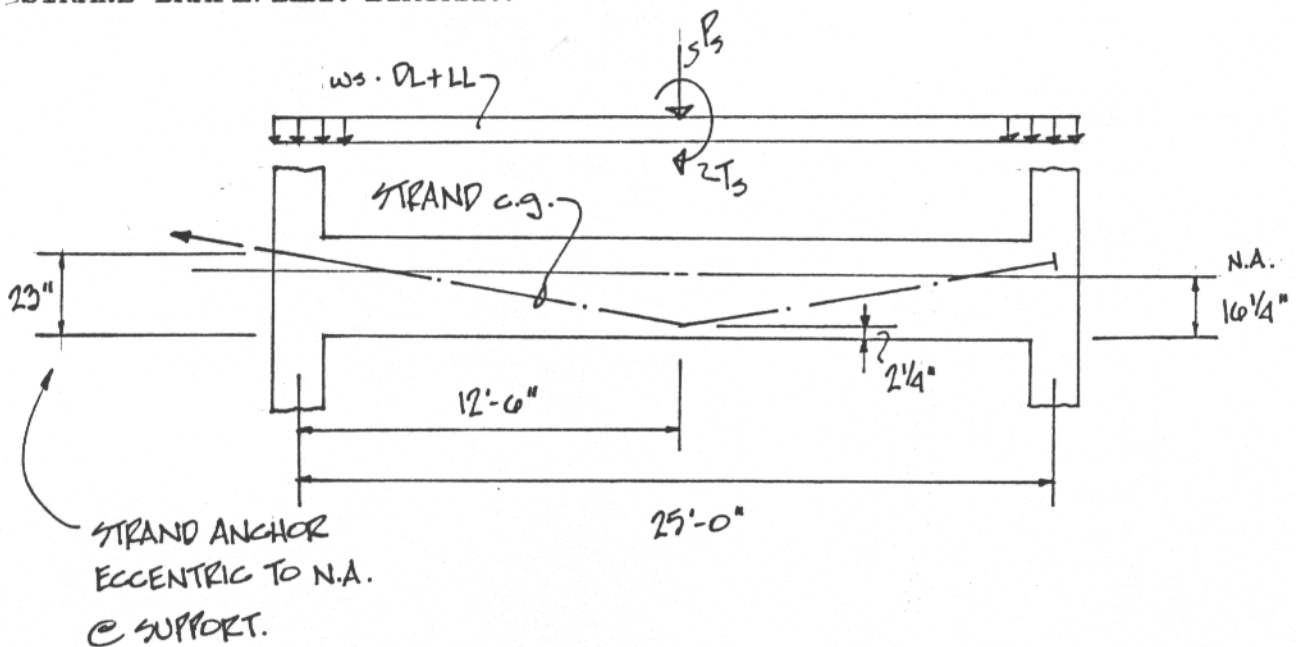

## DESIGN EXAMPLE

## LOADING:

$$w_s\text{-DL} = ((1629/144) * 150 \text{ PCF}) = 1.7 \text{ KLF}$$

beam

$$LL = (75/12) * 30 \text{ PSF} = .1875 \text{ KLF}$$

ASSUME: BEAM REACTION IS THE SAME AS TYPICAL BEAM AT EXTERIOR COLUMN.

$$P_s\text{-DL} = 78.53 * 77.7\% = 61.02 \text{ KIPS}$$

$$LL = 78.53 * 22.3\% = 17.51 \text{ KIPS}$$

$$T_s\text{-DL} = 511.27 * 77.7\% = 397.26 \text{ KF}$$

$$LL = 511.27 * 22.3\% = 114.01 \text{ KF}$$

ASSUME: UNIFORM DISTRIBUTION OF  $T_s$  TO SUPPORTING COLUMNS.

$$T_u = (1.47 * 511.27) / 2 = 375.78 \text{ KF}$$

## NOTES:

- SEE POST-TENSION LOSS PROGRAM PRINTOUT FOR ALL P/T LOSSES,  $w_b$  AND STRAND DRAPE LOCATION. (SHEET NO# 14&15)
- SEE ONE STORY FRAME ANALYSIS PROGRAM PRINTOUT FOR ALL GRAVITY AND BALANCING LOAD MOMENTS AND SHEARS. (SHEET NO# 16)

## POST TENSION LOSS PROGRAM

-----

TRANSFER BEAM 48"x 30"/CRSI

NUMBER OF SPANS = 1  
 LEFT CANTILEVER NO  
 RIGHT CANTILEVER NO  
 STRAND SIZE = 1/2inch  
 fpu = 270 ksi  
 Aps = .153 in<sup>2</sup>  
 E = 28500 ksi  
 WEDGE SET = .25 inch  
 FRICTION COEFFICIENT(u) = .07  
 WOBBLE FACTOR(k) = .0014  
 LOW-LAX STRAND YES  
 STRESS-RELIEVED STRAND NO  
 SLAB SECTION NO  
 BEAM OR JOIST SECTION YES

SPAN	LENGTH (ft)	LEFT SUPPORT ECC.(inch)	MIDSPAN ECC.(in.)	RIGHT SUPPORT ECC.(inch)
1	25	6.75	-14	6.75

JACKING FORCE= .75 fpuAps = 30.9825 kips  
 ANCHOR SET LOSS = 3.63375 kips  
 LIVE END ANCHORED FORCE = 27.3487 kips  
 MAXIMUM LE ANCHORAGE FORCE=.70fpuAps = 28.917 kips  
 LENGTH OF STRAND INFLUENCED BY ANCHOR SET > 25 ft.  
 DEAD END ANCHORED FORCE = 27.943 kips  
 TOTAL ANGULAR CHANGE = .276667 radians

LONGTERM LOSSES= 3.06 kips

## BALANCING LOADS

SPAN	h(inch)	P/T(kips) (AVE.NET)	wb(klf)
1	20.75	24.58	.544

STRAND LOCATION  
(PARABOLIC DRAPE)

[AS MEASURED FROM N.A.:+ ABOVE/- BELOW (inches)]						
SPAN NO#	FACE OF LEFT SUPPORT	h/2 FROM FOS	2/10	3/10	4/10	5/10
1	3.56	-0.05	-6.53	-10.68	-13.17	-14.00

SPAN NO#	6/10	7/10	8/10	h/2 FROM FOS	FACE OF RIGHT SUPPORT
1	-13.17	-10.68	-6.53	-0.05	3.56

## DESIGN EXAMPLE

## ONE STORY FRAME ANALYSIS:

TRANSFER BEAM/CRSI *ws-pl*

E= 3605 KSI  
SPAN LENGTH INERTIA  
1 25 110311

JOINT LENGTH INERTIA  
NO. ft. in<sup>4</sup>  
ALL 12 27648  
ALL 12 27648  
+I=FIXED -I=PINNED

LOAD OPTIONS  
1=UNIFORM LOAD (5)  
2=CONCENTRATED LOAD (12)  
3=TRIANGULAR LOAD (5)  
4=CONCENTRATED MOMENT(5)  
5=DUPLICATE LOADS  
6=END LOADING  
( ) INDICATES THE MAX. NO.  
OF LOADS(D+L)PER SPAN

LOAD	BEGIN	ENDS
K/K/FT	FT	FT
SPAN: 1		
W	1.70	0.00 25.00
P	61.02	12.50

JOINT 0  
COLUMN ABOVE 94.41 kft  
COLUMN BELOW 94.41 kft  
CLOCKWISE +

SPAN 1	X	SHEAR	MOMENT
	0.00	51.76	-188.82
	2.50	47.51	-64.74
	5.00	43.26	48.73
	7.50	39.01	151.56
	10.00	34.76	243.78
	12.50	30.51	325.36
	15.00	-34.76	243.78
	17.50	-39.01	151.56
	20.00	-43.26	48.73
	22.50	-47.51	-64.74
	25.00	-51.76	-188.82

INFLECTION POINTS:  
3.93 ft 21.07 ft  
MAX. DEFLECTION=  
0.060 in +4

JOINT 1  
COLUMN ABOVE -94.41 kft  
COLUMN BELOW -94.41 kft

TRANSFER BEAM/CRSI *ws-LL*

E= 3605 KSI  
SPAN LENGTH INERTIA  
1 25 110311

JOINT LENGTH INERTIA  
NO. ft. in<sup>4</sup>  
ALL 12 27648  
ALL 12 27648  
+I=FIXED -I=PINNED

LOAD OPTIONS  
1=UNIFORM LOAD (5)  
2=CONCENTRATED LOAD (12)  
3=TRIANGULAR LOAD (5)  
4=CONCENTRATED MOMENT(5)  
5=DUPLICATE LOADS  
6=END LOADING  
( ) INDICATES THE MAX. NO.  
OF LOADS(D+L)PER SPAN

LOAD	BEGIN	ENDS
K/K/FT	FT	FT
SPAN: 1		
W	0.19	0.00 25.00
P	17.51	12.50

JOINT 0  
COLUMN ABOVE 21.80 kft  
COLUMN BELOW 21.80 kft  
CLOCKWISE +

SPAN 1	X	SHEAR	MOMENT
	0.00	11.10	-43.61
	2.50	10.63	-16.45
	5.00	10.16	9.54
	7.50	9.69	34.36
	10.00	9.22	58.01
	12.50	8.75	80.48
	15.00	-9.22	58.01
	17.50	-9.69	34.36
	20.00	-10.16	9.54
	22.50	-10.63	-16.45
	25.00	-11.10	-43.61

INFLECTION POINTS:  
4.08 ft 20.92 ft  
MAX. DEFLECTION=  
0.014 in +4

JOINT 1  
COLUMN ABOVE -21.80 kft  
COLUMN BELOW -21.80 kft

TRANSFER BEAM/CRSI *wp*

E= 3605 KSI  
SPAN LENGTH INERTIA  
1 25 110311

JOINT LENGTH INERTIA  
NO. ft. in<sup>4</sup>  
ALL 12 27648  
ALL 12 27648  
+I=FIXED -I=PINNED

LOAD OPTIONS  
1=UNIFORM LOAD (5)  
2=CONCENTRATED LOAD (12)  
3=TRIANGULAR LOAD (5)  
4=CONCENTRATED MOMENT(5)  
5=DUPLICATE LOADS  
6=END LOADING  
( ) INDICATES THE MAX. NO.  
OF LOADS(D+L)PER SPAN

LOAD	BEGIN	ENDS
K/K/FT	FT	FT
SPAN: 1		
W	-0.54	0.00 25.00

JOINT 0  
COLUMN ABOVE -9.58 kft  
COLUMN BELOW -9.58 kft  
CLOCKWISE +

SPAN 1	X	SHEAR	MOMENT
	0.00	-6.80	19.16
	2.50	-5.44	3.86
	5.00	-4.08	-8.04
	7.50	-2.72	-16.54
	10.00	-1.36	-21.64
	12.50	0.00	-23.34
	15.00	1.36	-21.64
	17.50	2.72	-16.54
	20.00	4.08	-8.04
	22.50	5.44	3.86
	25.00	6.80	19.16

INFLECTION POINTS:  
21.69 ft 3.31 ft  
MAX. DEFLECTION=  
-0.006 in +4

JOINT 1  
COLUMN ABOVE 9.58 kft  
COLUMN BELOW 9.58 kft

$$\text{ULTIMATE LOAD FACTOR} = (1A * 325.30 + 1.7 * 80.48) / 409.8A = 1.40$$

POST-TENSION SERVICE STRESS

SHEET NO# 17

REFERENCE CODE: TRANSFER BEAM/MAX POSITIVE MOMENT/CRSI

SPAN (ft)=	25	h (in) =	30
Sb (in3) =	6755.1	yb (in) =	16.33
St (in3) =	8069.5	yt (in) =	13.67
Ag (in2) =	1629		
Ms (KF) =	405.84	MsDLi (KF)=	325.36
f'c(psi) =	4000	f'ci(psi) =	2400

FOR 1 STRAND:

Mb (KF) =	-23.34	INITIAL LOSSES(%)=	3
P/T(kips)=	24.58	LONGTERMLOSSES(K)=	3.06
Aps(in2) =	0.153		

NUMBER OF STRANDS REQ'D = 4.36079 [7.5\*SQRT f'c]

DESIRED NO# OF STRANDS = 9 fa(P/A)= 135.801 P/Amin= 125psi

		SERVICE	INITIAL
STRESS AT fb (psi) =	-211.99		-22.83
9 STRANDS:ft (psi) =	426.942		291.236
ALLOWABLE f/tension (psi)=	-474.34		-146.97
STRESS: f/comp. (psi) =	1800		1440

UNBONDED ULTIMATE STRENGTH

	ONE-WAY BM/SLAB	TWO-WAY PLATE
NO=0;YES=1	1	0
ULTIMATE LOAD FACTOR =	1.46	SPAN/DEPTH RATIO = 10
bw(in) =	48	
bf(in) =	75	
dp(in) =	27.75	
d (in) =	27.5	
e (in) =	14	
hf (in)=	7	
MINIMUM BONDED As(in2)=	3.13536	fy(ksi)= 60
DESIRED REINF. As(in2)=	3.52	w = 0.0256
Pps =	0.00066	wp = 0.03823
fse (ksi)=	160.654	w + wp = 0.06383
fps (ksi)=	231.111	MAX w + wp = 0.306
SECONDARY EFFECT(KF) =	48.03	
Mu (KF) =	640.556	
PhiMn (KF) =	1056.72	ADEQ. REINF. PROVIDED
1.2*Mocr (KF) =	664.23	ADEQ. REINF. PROVIDED

/B.#6

POST-TENSION SERVICE STRESS

SHEET NO# 18

REFERENCE CODE: TRANSFER BEAM/-Ms @ FACE OF SUPPORT/CRSI

SPAN (ft)=	25	h (in) =	30
Sb (in3) =	6755.1	yb (in) =	16.33
St (in3) =	8069.5	yt (in) =	13.67
Ag (in2) =	1629		
Ms (KF) =	-170.51	MsDLi (KF)=	-137.91
f'c(psi) =	4000	f'ci(psi) =	2400

FOR 1 STRAND:

Mb (KF) =	12.63	INITIAL LOSSES(%)=	3
P/T(kips)=	24.58	LONGTERMLOSSES(K)=	3.06
Aps(in2) =	0.153		

NUMBER OF STRANDS REQ'D = -6.5183 [7.5\*SQRT f'c]

DESIRED NO# OF STRANDS = 9    fa(P/A)= 135.801    P/Amin= 125psi

		SERVICE	INITIAL
STRESS AT fb (psi) =		236.774	172.86
9 STRANDS:ft (psi) =		51.2754	127.42
ALLOWABLE f/tension (psi)=	-474.34		-146.97
STRESS: f/comp. (psi) =	1800		1440

UNBONDED ULTIMATE STRENGTH

	ONE-WAY BM/SLAB	TWO-WAY PLATE
NO=0;YES=1	1	0
ULTIMATE LOAD FACTOR =	1.46	SPAN/DEPTH RATIO = 10
bw(in) =	48	
bf(in) =	75	
dp(in) =	19.81	
d (in) =	27.5	
e (in) =	3.56	
hf (in)=	7	
MINIMUM BONDED As(in2)=	3.38064	fy(ksi)= 60
DESIRED REINF. As(in2)=	3.52	w = 0.04
Pps =	0.00145	wp = 0.07178
fse (ksi)=	160.654	w + wp = 0.11178
fps (ksi)=	198.275	MAX w + wp = 0.306
SECONDARY EFFECT(KF) =	48.0414	
Mu (KF) =	-200.9	
PhiMn (KF) =	-787.37	ADEQ. REINF. PROVIDED
1.2*Mocr (KF) =	-628.76	ADEQ. REINF. PROVIDED

*1/8" #6*

## DESIGN EXAMPLE

TORSIONAL SECTION PROPERTIES:

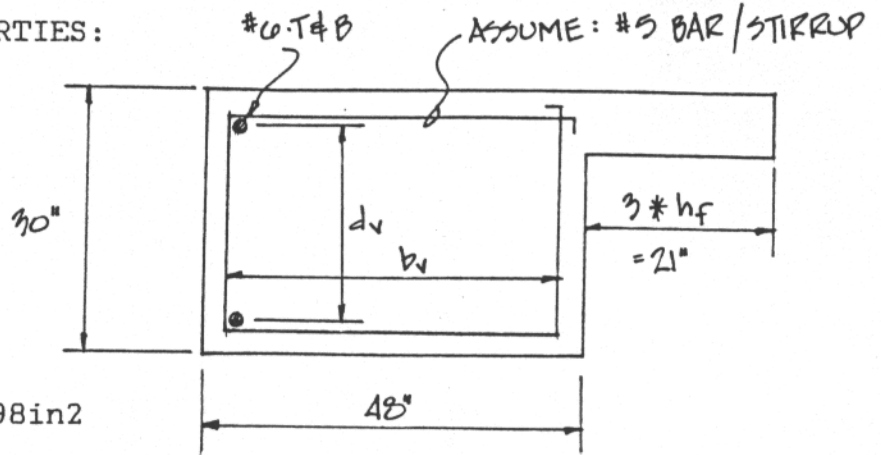

$$P_c = (48 + 30 + 69 + 7 + 21 + 23) = 198 \text{ in}^2$$

$$A_c = (48 * 30) + (21 * 7) = 1587 \text{ in}^2$$

$$d_v = 30 - [(2 * 1.5) + (2 * .625) + .75] = 25 \text{ in}$$

$$b_v = 48 - (2 * 1.5) = 45 \text{ in}$$

DETERMINE  $V_p$ :

$$\tan \theta = 20.75" / 150" = .1383; \theta = 7.876 \text{ DEGREES}$$

$$V_p = (9 * 24.58) * \sin \theta = 30.313 \text{ KIPS}$$

ULTIMATE BEAM SHEAR/TORSION ANALYSIS

SHEET NO# 20

LOCATION	1	2	3	4	5	6
DISTANCE	2.25	2.5	5	7.5	10	12.5
Vu(kips)	85.26	84.56	77.84	71.09	64.34	57.59
M <sub>s</sub> (KE)	-95.76	-81.19	58.27	185.92	301.79	405.84
Tu(KE)	375.78	375.78	375.78	375.78	375.78	375.78
(TOTAL) Mb(KE)	47.13	34.74	-72.36	-148.86	-194.76	-210.36
Ac(in <sup>2</sup> )	1587	1587	1587	1587	1587	1587
Pc(in)	198	198	198	198	198	198
bv(in)	45	45	45	45	45	45
dv(in)	25	25	25	25	25	25
Aoh(in <sup>2</sup> )	1125	1125	1125	1125	1125	1125
ph(in)	140	140	140	140	140	140
dp(in)	16.2	16.1	20.28	24.43	26.92	27.75
e(in)	0	0	6.53	10.68	13.17	14
Vp(kips)	30.313	30.313	30.313	30.313	30.313	30.313
f <sub>ps</sub> (ksi)	193.242	193.102	214.837	223.878	229.303	231.111
A <sub>s</sub> (in <sup>2</sup> )	3.52	3.52	3.52	3.52	3.52	3.52
d(in)	27.5	27.5	27.5	27.5	27.5	27.5
Mu(KE)	-92.68	-83.797	133.095	319.469	488.642	640.256
PhiM <sub>n</sub> (KE)	-706.56	-704.37	847.752	960.761	1032.26	1056.72
1.2M <sub>ocr</sub> (KE)	-548.91	-534.04	498.99	590.79	645.87	664.59
*INCREASE REINF.	NO	NO	NO	NO	NO	NO *(FLEXURAL)
Phi* <sub>67</sub> T <sub>ocr</sub> (KE)	189.322	189.322	189.322	189.322	189.322	189.322
*Tu REINE. REQ'D	YES	YES	YES	YES	YES	YES *(STIRRUPS)
tn(KSI)	0.64905	0.64832	0.6413	0.63424	0.62718	0.62012
THETA MIN	23.5896	23.5743	23.4271	23.2793	23.1315	22.9837
THETA MAX	60.1097	60.1321	60.3475	60.5638	60.7801	60.9965
INCREASE SECTION	NO	NO	NO	NO	NO	NO (SEE NOTE 1)
ATHETA(degrees)	41.8496	41.8532	41.8873	41.9216	41.9558	41.9901*(AVERAGE)
V <sub>ocr</sub> (kips)	391.599	391.599	391.599	398.072	435.556	448.05
INCREASE SECTION	NO*	NO*	NO*	NO*	NO*	NO* *(V <sub>cr</sub> >V <sub>s</sub> )
THETA/ACTUAL	41.8496	41.8532	41.8873	41.9216	41.9558	41.9901
ao(in)	1.54366	1.54364	1.54341	1.54319	1.54296	1.54275
Ao(in <sup>2</sup> )	1016.94	1016.95	1016.96	1016.98	1016.99	1017.01
At(in <sup>2</sup> /ft)	0.46724	0.4673	0.46785	0.46841	0.46897	0.46952
Av(in <sup>2</sup> /ft)	0.50152	0.49568	0.43955	0.38304	0.32638	0.26959*(SEE ABOVE)
Av+2At(in <sup>2</sup> /ft)	0.02738	0.02738	0.02738	0.02714	0.02586	0.02547 (MIN)
.....						
STIRRUP TYPES:	A;[ ]		B;[ ]		C;[ ]	[ ]
BAR SIZE	5	5	5	5	5	5
BAR AREA	0.31	0.31	0.31	0.31	0.31	0.31 (in <sup>2</sup> /LEG)
BAR TYPE	B	B	B	B	B	B
REQ'D SPACING	10.36	10.4	10.82	11.27	11.77	12 (in.)
.....						
DELTA Nu(kips)	337.864	337.668	335.885	334.261	332.805	331.519
MIN M <sub>n</sub> (KE)	-508.95	-499.02	559.507	764.599	950.786	1117.67
LONG. REINE. REQ'D	NO	NO	NO	NO	NO	NO *(MIN M <sub>n</sub> >Phi M <sub>n</sub> / .90)

NOTE 1: CHECK TO INSURE THAT THE TRANSVERSE REINFORCEMENT YIELDS BEFORE BEFORE DIAGONAL CRUSHING OF THE CONCRETE.

DESIGN EXAMPLE : TRANSFER BEAM 48" x 30" / -M<sub>3</sub> @ FACE OF SUPPORT

NOTE: SEE SHEET NO# 18, 19 & 20 FOR PROGRAM OUTPUT VALUES CORRESPONDING TO FOLLOWING HAND CALCULATIONS.

$$\text{NUMBER OF STRANDS REQ'D} = \frac{(((-170.51 \text{ KF} * 12) - (8009.5 * 7.5 * \sqrt{4000}) / 1000) - 6.52)}{((12.63 * 12) + ((8009.5 * 24.58) / 1629))}$$

$$f_a = (24.58 \text{ K} * 9) / 1629 * 1000 = 139.8 \text{ psi}$$

$$f_b = ((24.58 * 9 * 1000) / 1629) - ((-170.51 * 12000) / 6755.1) - ((12.63 * 9 * 12000) / 6755.1)$$

$$= 236.77 \text{ psi (SERVICE)}$$

$$f_b = (9 * ((24.58 + 3.06) * (1 - (3.0/100)))) * (1000 / 1629) - ((-137.91 * 12000) / 6755.1)$$

$$- (12.63 * (((24.58 + 3.06) / 24.58) * (1 - (3.0/100)))) * 9 * 12000 / 6755.1$$

$$= 172.86 \text{ psi (INITIAL)}$$

$$f_t = ((24.58 * 9 * 1000) / 1629) + ((-170.51 * 12000) / 8009.5) + ((12.63 * 9 * 12000) / 8009.5)$$

$$= 51.27 \text{ psi (SERVICE)}$$

$$f_t = (9 * ((24.58 + 3.06) * (1 - (3.0/100)))) * (1000 / 1629) + ((-137.91 * 12000) / 8009.5)$$

$$+ (12.63 * (((24.58 + 3.06) / 24.58) * (1 - (3.0/100)))) * 9 * 12000 / 8009.5$$

$$= 127.42 \text{ psi (INITIAL)}$$

ALLOWABLE STRESSES:

$$f_{\text{tension}} = 7.5 * \sqrt{4000} = 474.94 \text{ psi (SERVICE)}$$

$$= 3 * \sqrt{2400} = 146.97 \text{ psi (INITIAL)}$$

$$f_{\text{comp.}} = .45 * 4000 = 1800 \text{ psi (SERVICE)}$$

$$= .60 * 2400 = 1440 \text{ psi (INITIAL)}$$

$$\text{SPAN/DEPTH RATIO} = (25 * 12) / 30 = 10$$

$$\text{MINIMUM BONDED } A_s = .004 * ((7 * 75") + ((13.67" - 7") * 48")) = 3.38 \text{ IN}^2$$

$$e_{ps} = (9 * .153) / (48 * 19.81) = .00145$$

$$f_{se} = 24.58 / .153 = 160.65 \text{ KSI} ; f_{ps} = 160.65 + 10 + \frac{(4000/100 * e_{ps})}{1000} = 198.27 \text{ KSI}$$

$$w = ((3.52) / (48 * 27.5)) * 600 \text{ KSI} / 4 \text{ KSI} = .04$$

$$w_p = e_{ps} * f_{ps} / 4 \text{ KSI} = .0718$$

$$.1118 = w + w_p < .36 * \beta_1 = .36 * .85 = .306$$

$$\text{SECONDARY EFFECT} = (12.63 * 9) - ((9.56/12) * 24.58 * 9) = 48.04 \text{ KF}$$

$$M_u = (1.46 * -170.51) + 48.04 = -200.9 \text{ KF}$$

$$\text{Phi}M_n \Rightarrow F_t = (.153 * 9 * f_{ps}) + (3.52 * 60 \text{ ksi}) = 484.22 \text{ K}$$

$$a = (F_t * 1000) / (.25 * 4000 * 48) = 2.967''$$

$$\phi M_n = (-.90 * ((.153 * 9 * f_{ps} * (d_p - a/2)) + (3.52 * 60 * (d - a/2)))) / 12$$

$$= -787.97 \text{ KF}$$

$$1.2 * M_{ocr} = 1.2 * \left( \left( \frac{-8069.5}{12000} \right) * \left( (7.5 * \sqrt{4000}) + \left( \frac{(24.58 * 9)}{1629} \right) + \left( \frac{(12.63 * 9 * 12)}{8069.5} \right) * 1000 \right) \right)$$

$$= -628.76 \text{ KF}$$

### ULTIMATE BEAM SHEAR/TORSION ANALYSIS

$$A_{oh} = (45'' * 25'') = 1125 \text{ in}^2$$

$$p_h = (2 * 45'') + (2 * 25'') = 140''$$

$f_{ps} \Rightarrow$  CALCULATED THE SAME AS THAT SHOWN ON SHEET #1; SUBSTITUTE  $d_p = 16.2''$

$$e_{ps} = .0018; f_{ps} = 193.24 \text{ ksi}$$

$$M_u = (1.46 * -95.76) + (47.13 \text{ KF} - ((-0-12) * 24.58 * 9)) = -92.68 \text{ KF}$$

$\text{Phi}M_n \Rightarrow$  CALCULATED THE SAME AS  $\text{Phi}M_n$  ABOVE; SUBSTITUTE  $d_p = 16.2''$

$$F_t = 477.29 \text{ K}; a = 2.925''; \phi M_n = -706.55 \text{ KF}$$

$1.2 * M_{ocr} \Rightarrow$  CALCULATED THE SAME AS  $1.2 * M_{ocr}$  ABOVE; SUBSTITUTE  $M_b = 47.13 \text{ KF}$

$$= -548.91 \text{ KF}$$

$$\text{Phi} * .67 * T_{ocr} = .25 * .67 * \left( \frac{((1987^2) / 198) * (4 * \sqrt{4000})}{\left( \sqrt{1 + \left( \frac{((24.58 * 9) / 1629) * 1000}{(4 * \sqrt{4000})} \right)} \right)} \right) / 12000$$

$$= 189.32 \text{ KF}$$

$$t_n = \left( \frac{((25.26 / .25 - 30.313) / (45 * 25)) + \left( \frac{((375.78 / .25) * 12 * 140)}{1125^2} \right)}{.6491 \text{ ksi}} \right) = .6491 \text{ ksi}$$

$$\text{THETA MIN} = 10 + (39.75 * (t_n / (4000/1000))) = 23.589^\circ$$

$$\text{THETA MAX} = 80 - (122.58 * (t_n / (4000/1000))) = 60.11^\circ$$

$$\frac{39.7}{2} = 41.85^\circ \text{ AVE}$$

$$V_{out} = \frac{(((48 * 24 * (4 * \sqrt{4000}))) * (\sqrt{1 + (((24.98 * 9) / 1629) * 1000) / (4 * \sqrt{4000}))))}{1000}$$

$$= 361.27 + 30.313 = 391.60 \text{ K}$$

$$a_0 = \frac{(1125 / 140) * (1 - \sqrt{1 - (((375.78 / .85) * 12000 * 140) / (.85 * 4000 * 1125^2))}}{((\tan 41.85^\circ) + (1 / (\tan 41.85^\circ))))}$$

$$= 1.9437$$

$$A_0 = 1125 - ((a_0 * 140) / 2) = 1016.94$$

$$A_{\pm} = 12 * (((375.78 / .85) * 12 * (\tan 41.85^\circ)) / (2 * A_0 * 60)) = .4673 \text{ IN}^2 / \text{FT}$$

$$A_r = 12 * (((.85 * 26 / .85) - 30.313) * (\tan 41.85^\circ)) / (60 * 25) = .9015 \text{ IN}^2 / \text{FT}$$

$$\text{(MIN)} A_r + 2A_{\pm} = ((.153 * 9) / 80) * (270 / 60) * (12 / 24) * \sqrt{24 / 48} = .0274 \text{ IN}^2 / \text{FT}$$

$$\text{REQ'D SPACING} = .91 \text{ IN}^2 / (((.9015 / 24) + (.4673 / 12)) / 2) = 10.36"$$

(TYPE "B" STIRRUP)

$$\text{DELTA} \cdot N_u = \frac{(1 / (\tan 41.85^\circ)) * \sqrt{(((.85 * 26 - (.85 * 30.313))^2) + (((375.78 * 12 * (140 - (4 * a_0))) / (2 * A_0))^2))}}{1000}$$

$$= 337.86 \text{ K}$$

$$\text{MIN} M_n = (((25 * 375.78 * 12 * (140 - (4 * a_0))) / (2 * (\tan 41.85^\circ) * .85 * 2 * A_0)) - (12 * (-92.6796 / .90))) / 12$$

$$= 508.94 \text{ KF}$$

CHECK: SERVICE STRESS PORTION OF PROGRAM FOR CALCULATION OF BONDED AUXILIARY TENSION REINFORCEMENT AND  $f'_{ci}$  MIN. SEE SHT. # 5 FOR CORRESPONDING PROGRAM PRINTOUT OF ADAPTATION OF EXAMPLE USED ON SHT. # 1.

INITIAL STRESS  $e f_b >$  ALLOWABLE

$$A_{s \text{ req'd}} = \frac{((|-147.71|) / ((|-147.71| + |1005.21|) / 30'')) * |-147.71| / 2 * 48''}{30000 \text{ psi}}$$

$$= .2987 \text{ in}^2$$

$e f_t >$  ALLOWABLE

$$f'_{ci \text{ min}} = 1005.71 / .60 = 2675.35 \text{ psi}$$

POST-TENSION SERVICE STRESS

SHEET NO# 5

REFERENCE CODE: TRANSFER BEAM/-Ms @ FACE OF SUPPORT/CRSI			
SPAN (ft)=	25	h (in) =	30
Sb (in3) =	6755.1	yb (in) =	16.33
St (in3) =	8069.5	yt (in) =	13.67
Ag (in2) =	1629		
Ms (KF) =	-170.51	MsDLi (KF)=	-137.91
f'c(psi) =	4000	f'ci(psi) =	2400
FOR 1 STRAND:			
Mb (KF) =	12.63	INITIAL LOSSES(%)=	3
P/T(kips)=	24.58	LONGTERMLOSSES(K)=	3.06
Aps(in2) =	0.153		
NUMBER OF STRANDS REQ'D =		-6.5183 [7.5*SQRT f'c]	
DESIRED NO# OF STRANDS =	49	fa(P/A)= 739.362	P/Amin= 125psi
		SERVICE	INITIAL
STRESS AT fb (psi) =	-57.121	-147.71	Asreq'd 0.29871
49 STRANDS:ft (psi) =	1406.11	1605.21	f'cimin 2675.36
ALLOWABLE f/tension (psi)=	-474.34	-146.97	
STRESS: f/comp. (psi) =	1800	1440	

CHECK: ULTIMATE BEAM SHEAR PORTION OF PROGRAM. SEE SHT #7 FOR CORRESPONDING PROGRAM PRINTOUT FOR DESIGN EXAMPLE USED ON SHT. #1 ASSUMING  $T_U = -0$  AND  $V_U$  AT  $h/2$  FROM THE FACE OF THE SUPPORT EQUALS 341.04 K.

$$V_c \Rightarrow V_{udp} / M_U = (341.04 * 16.2) / |(-139.81 * 12)| = 3.29 > 1.0$$

$$= \frac{((.60 * \sqrt{4000}) + (700 * 1)) (24 * 48)}{1000} = 850.12 \text{ K} \quad \text{WHERE: } d_{\text{MIN}} = .80h = 24"$$

$$V_c \text{ MIN} = (2 * \sqrt{4000} * 24 * 48) / 1000 = 145.72 \text{ K}$$

$$\text{MAX} = 5 \sqrt{f'_c} b_w d = 364.29 \text{ K}$$

ARE STIRRUPS REQ'D?  $.85 * V_c \text{ MAX} = 309.65 \text{ K} < V_U$  YES/REQ'D

REQ'D SPACING  $\Rightarrow$  MIN SPACING =  $.75 * h = 22.5" < 24"$

$$= \frac{((.20 * 2) * 60 * 24)}{((341.04 / .85) - 364.29)} = 15.59", \text{ FOR \#4 STIRRUP}$$

$$A_v \text{ MIN} = ((9 * .159) / 80) * (270 / 60) * (15.59 / 24) * \sqrt{24 / 48} = .03596 \text{ IN}^2$$

$$V_s = ((.20 * 2) * 60 * 24) / 15.59 = 36.92 \text{ K}$$

$$\phi V_n = .85 * (36.92 + 364.29) = 341.04 \text{ K}$$

ULTIMATE BEAM SHEAR ANALYSIS

SHEET NO# 7

LOCATION	1	2	3	4	5	6	
DISTANCE	2.25	2.5	5	7.5	10	12.5	
Vu(kips)	341.04	84.56	77.84	71.09	64.34	57.59	
Mu(KF)	-139.81	-118.54	85.07	271.44	440.61	592.53	
dp(in)	16.2	16.1	20.28	24.43	26.92	27.75	
Vc(kips)	850.115	815.498	850.115	482.161	345.336	260.112	
VcMIN(K)	145.718	145.718	145.718	148.329	163.447	168.486	
VcMAX(K)	364.294	364.294	364.294	370.821	408.617	421.215	
STIRRUPS	REQ'D	N/R	N/R	N/R	N/R	N/R	fy
BAR SIZE	4	4	4	4	4	4	60ksi
BAR AREA	0.2	0.2	0.2	0.2	0.2	0.2	
MIN SPCG	22.5	22.5	22.5	22.5	22.5	22.5	
REQ'D SPCG(in)	15.6	22.5	22.5	22.5	22.5	22.5	
AvMIN(in <sup>2</sup> )	0.0356	N/A	N/A	N/A	N/A	N/A	(@SPCG)
STIRRUP TYPE	[_]	[_]	[_]	[_]	[_]	[_]	
Vs(kips)	36.9231	25.6	25.6	26.0587	28.7147	29.6	
PhiVn(K)	341.035	331.41	331.41	337.348	317.943	246.255	

CHECK: MAX  $\phi M_n$  FOR OVERREINFORCED SECTION CALCULATED ON SHT. #8  
OF DESIGN EXAMPLE; TYP. BM. 18" x 20" / -M<sub>s</sub> @ FACE OF INT. SUPPORT.

$w + w_p > \text{MAX ALLOWABLE}$

$$\phi M_n \cdot \text{MAX} = \frac{(-90 * ((4000/1000) * 18 * (21.64)^2 * ((.36 * .25) - (.08 * .252))))}{12}$$

=-1023.93 KF