

PWEagle

Wastewater Access & Cleanout/Sampling Chambers



Innovative
Polymer Products
for the Utilities
Industry

PWEagle

Waterworks
Products

A Long-Lasting, Cost-Effect

Introduction

The basic concept of a manhole has remained unchanged for more than 150 years. The original function was to provide an access point into the sanitary sewer system large enough to allow two men to enter and perform inspection and cleaning procedures manually. Over time, due to technology advances, the need for human entry into a manhole to perform routine maintenance operations has almost disappeared.

The latest developments follow the technological advances in both function and materials. PW Eagle has provided products consistent with the materials used in most sanitary sewer systems - plastics. For many years, Europeans have been developing and utilizing polymer technology to manufacture chambers to replace conventional manholes. In 1990, the introduction of the Wastewater Access Chamber (WAC) in Dallas, Texas, began the transition of the U.S. market away from conventional pre-cast or poured-in-place concrete manholes. Since the long-term performance of concrete, particularly in corrosive environments, has not met expectations,

the time is right! PVC sewer pipe has gained the major portion of the new and rehabilitation collection system market, so it's only natural to make the change to plastic access chambers. They not only provide a long lasting, cost effective alternative to concrete, but they are also effective in minimizing the dangers involved in human entry into confined spaces. What a winning combination!



The Concept

The Wastewater Access Chamber (WAC) and the Cleanout/Sampling Chamber (CSC) are rotational-molded polyethylene chambers designed to provide access into various locations in sanitary or storm drain systems for inspection, sampling and cleaning. The differentiation in the products are the physical size, the pipe sizes they connect to and the conditions in which they will be installed.

General Features

Heavy Wall Polyethylene Construction

- Lightweight for easy handling at job site
- Light color, better visibility on interior
- Lower installation costs
- Water tight
- Corrosion resistant
- Flexibility under earth load
- Excellent flow characteristics (n=.009)
- Economical compared to conventional manholes
- Adaptable to all pipe materials
- Smooth interior reduces cleaning frequency
- One-piece, molded construction
- Eliminates man entry for maintenance purposes
- Reusable in other locations
- Resistant to shipping damage
- Resistant damage from mechanical cleaning equipment
- Proven material history
- Excellent Environmental Stress Crack Resistance (ESCR)

Inlets/Outlets Designed To Accommodate Standard Pipe Connections With Flexible Connectors

- Conventional installation procedures
- Water tight joints
- No special components required
- No special tools required

ive Alternative to Concrete

Wastewater Access Chamber Features

Chamber Body

- Sturdy, 3/8" thick, one-piece construction - no welds!
- Smooth interior improves the flow ($n=.009$) through molded inverts
- Large enough for easy insertion of CCTV equipment and high pressure cleaning equipment
- Design resists floating in high ground water conditions
- Light color allows for excellent internal visibility

15" Riser Pipe On WAC

- Large enough to allow equipment entry, too small for human entry
- Water tight lid with gasket installs on top of riser
- Extends or shortens easily
- Eliminates need for confined space entry procedures and equipment
- Due to 15" size, riser remains independent of standard ring and cover

Surface Treatment

- Standard ring and cover installed on concrete base remains independent of riser pipe - no traffic loading transferred to riser or chamber
- Polyethylene lid with gasket installed in riser, under ring and cover to eliminate inflow into the system - no "dish" or casting to chimney sealing devices required!
- Freeze/Thaw cycle effect minimized
- Street paving adjustments made independently of chamber

WAC Installation

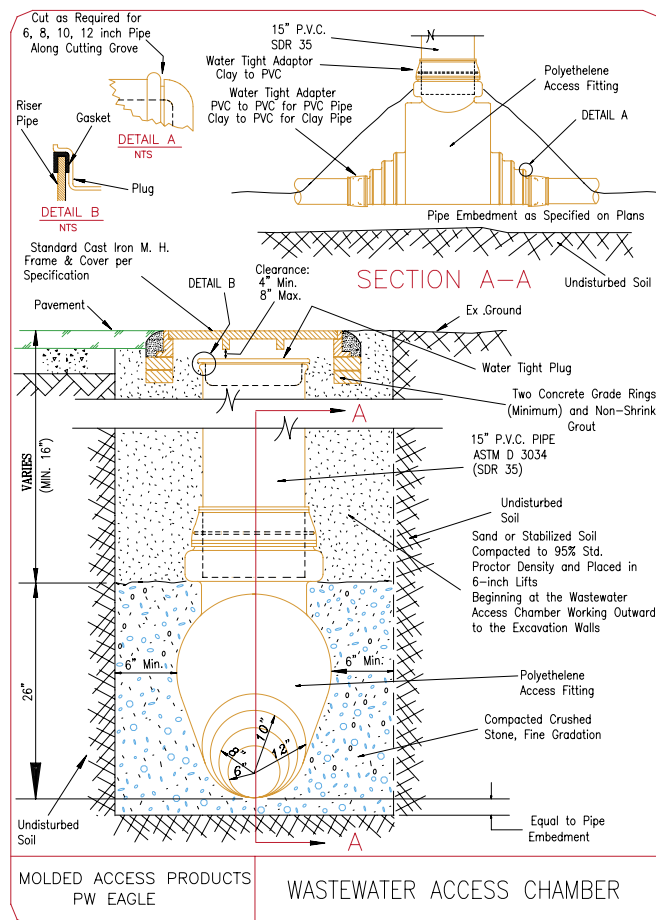

Dimensions Of Body

- Length 43.75" +/- 0.50"
- Height 37.75" +/- 0.50"
- Width 18" +/- 0.50"
- Thickness 0.375" average

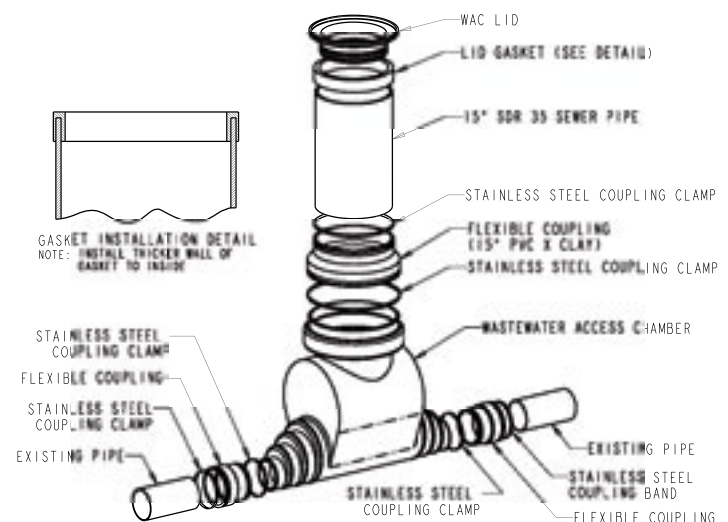

Exploded View of WAC 15

15" WAC Product Specifications

General

The Wastewater Access Chamber (WAC) may be used in place of standard concrete manholes, cleanouts, dead-end manholes, or sampling ports, or used in any location in a sewage or storm drainage collection system that requires access for maintenance

and inspection equipment, without man entry. The chamber shall be a one-piece, rotational molded polyethylene unit that is corrosion resistant, lightweight and designed for use in both traffic and non-traffic locations where the sewer pipe is 6-, 8-, 10- or 12 inches in diameter. The chamber shall be adaptable to

clay, cast iron, ductile iron, PVC or concrete pipe through use of flexible couplings.

Physical Dimensions

- Length of body shall be 43.75" +/- 0.50"
- Height shall be 37.75" +/- 0.50"
- Width shall be 18.75" +/- 0.50"
- Thickness shall be an average of 0.375"

Cleanout/Sampling Chamber Features

Chamber Body

- Sturdy 1/4" thick, one-piece construction - no welds!
- Smooth interior improves the flow (n=.009) through molded inverts
- Sized to allow access by pressure cleaning equipment and push-rod CCTV equipment
- Riser spigot designed to utilize 12" SDR 35 as well as 12" Ultra-Rib pipe
- 4" and 6" inlets and outlets connected to SDR 35 with flexible couplings
- Designed as a "Crow's Foot" to allow two services to be connected through one chamber, cutting main connections in half!

Dimensions of Chamber

- Length - 26.425" +/- 0.50"
- Height - 14.50" +/- 0.50"
- Width - 21.00" +/- 0.50"
- Thickness - 0.250" average

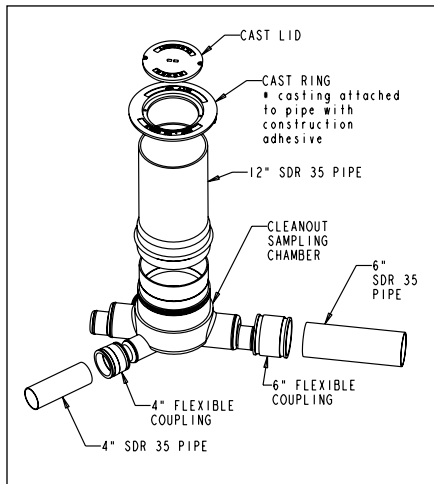

CSC Assembled Configuration

12" Riser Pipe On CSC

- Sized to keep opening large enough to accept standard pressure cleaning equipment and push-rod CCTV equipment
- Small enough to be installed in sidewalk, yard or easement relatively inconspicuously
- Polyethylene lid with gasket installs in top of riser to provide water tight seal
- SDR 35 or Ultra-Rib may be used as a riser
- Surface opening may be reduced through use of reducing couplings (rigid or flexible)
- Riser is cut to proper length at job site by installer

Surface Treatment

- Standard ring and cover set on a poured concrete pad may be used to gain access
- Smaller rings and covers are available for sidewalk, yard or easement applications
- Sealed polyethylene lid may be buried without ring and cover where complete concealment is desired

Common Uses

- Property line house cleanout (1-2 houses)
- Commercial grease trap sampling port



Cut-Away CSC



CSC Installation



CSC Installation

PWEagle manufactures PVC pipe for a variety of applications servicing the potable water, well casing, sewer, agriculture, turf, plumbing, communications and electrical markets.

PWEagle products are available from distributors throughout the United States and parts of Western Canada. Our eleven facilities in Washington, Oregon, California, Utah, Nebraska, Texas, Missouri and West Virginia assure on-time delivery.

P.O. Box 10049, Eugene, OR 97440 • (800) 347-0200 • (541) 343-0200 • FAX (541) 686-9257 • www.pweagleinc.com

