

ACCA Friction Rate Reference Chart

Table of Contents

Instructions		Pg. 2
ADC Compression gauge	Compress O Graph	Pg. 3
Friction Rate Worksheet	Simple Friction Rate Chart	Pg. 4
Group 1	Supply Air Fittings at Air Handler Equipment	Pg. 5
Group 2	Branch Takeoff Fitting at the Supply Trunk	Pg. 9
Group 3	Reducing Trunk Takeoff Fittings	Pg.12
Group 4	Supply Air Boot and Stack Head Fittings	Pg. 14
Group 5	Return Air Fittings at the Air Handler Equipment	Pg. 15
Group 6	Branch Return Air Fittings at the Return Trunk	Pg. 18
Group 7	Panned Joist and Panned Stud Return Air Fittings	Pg. 21
Group 8	Elbows and Offsets	Pg. 22
Group 9	Supply Trunk Junction Fittings	Pg. 24
Group 10	Return Trunk Junction Fittings	Pg.26
Group 11	Flexible Duct Junction Boxes and Radius Bends	Pg. 27
Group 12	Transitions	Pg. 28
Group 13	Manual Balancing Dampers	Pg. 31

ACCA Friction Rate Reference Chart

Instructions

Use this reference chart to help determine the Total Effective Length (TEL) of your duct system.

To use this system for design or troubleshooting, you must follow the steps below to find the Friction Rate based on the Total Available Static. NOTE: A ductulator only measures to 100ft. of duct.

1. Obtain a copy of the Room to Room load calculation for the complete zone the system serves.
2. Obtain a copy of the equipment Blower data sheet. (usually in the Installation Instructions of the equipment used)
3. Measure the length of the longest physical return and supply run to the equipment and add them together (A+B = Total physical length). Note the turns, bends, and sags, as well as the type of duct work used along the way for determining the TEL.
4. Utilizing this reference chart, add the correct added length for each turn, bend, and type of duct used for both return and supply runs you physically measured in the last step and add this to the total length. See example below (NOTE: use multiplier for flex duct sag per ADC compression gauge (pg. 3))

Measured length of duct (A to B) = 65 feet

Equivalent lengths of turns and fittings between A and B = 190 feet

Total effective length = 255 feet

5. Determine the External Static Pressure of the equipment from the Blower Data section, for the fan speed desired. (typically 0.5 for standard PSC motor @ high speed) (NOTE: CFM/Ton)
6. Add in the DSP (Device Pressure Losses) for filter resistance, electric heat strips, wet coil, dampers, registers, and grilles to find the Available Static Pressure. See Example below.

External static pressure of air handler @ 100 cfm	0.5" w.c
wet coil	-0.10" w.c.
Air filter	-0.15" w.c.
registers	-0.03" w.c
.Grille	-0.03" w.c.
Total Available Static Pressure	-0.19" w.c.

7. To find the Friction Rate of the duct system, use the formula $\frac{ASP \times 100}{TEL}$ see example

$$\text{Friction Rate} = \frac{.19 \times 100}{255}$$

= .075" w.c. (Size all ducts at this friction rate)

Your target Friction Rate is 0.08

ACCA Friction Rate Reference Chart

To determine TEL for flex duct with sag. NOTE: Code requires = $< \frac{1}{2}$ "per FT. supported every 5 FT.

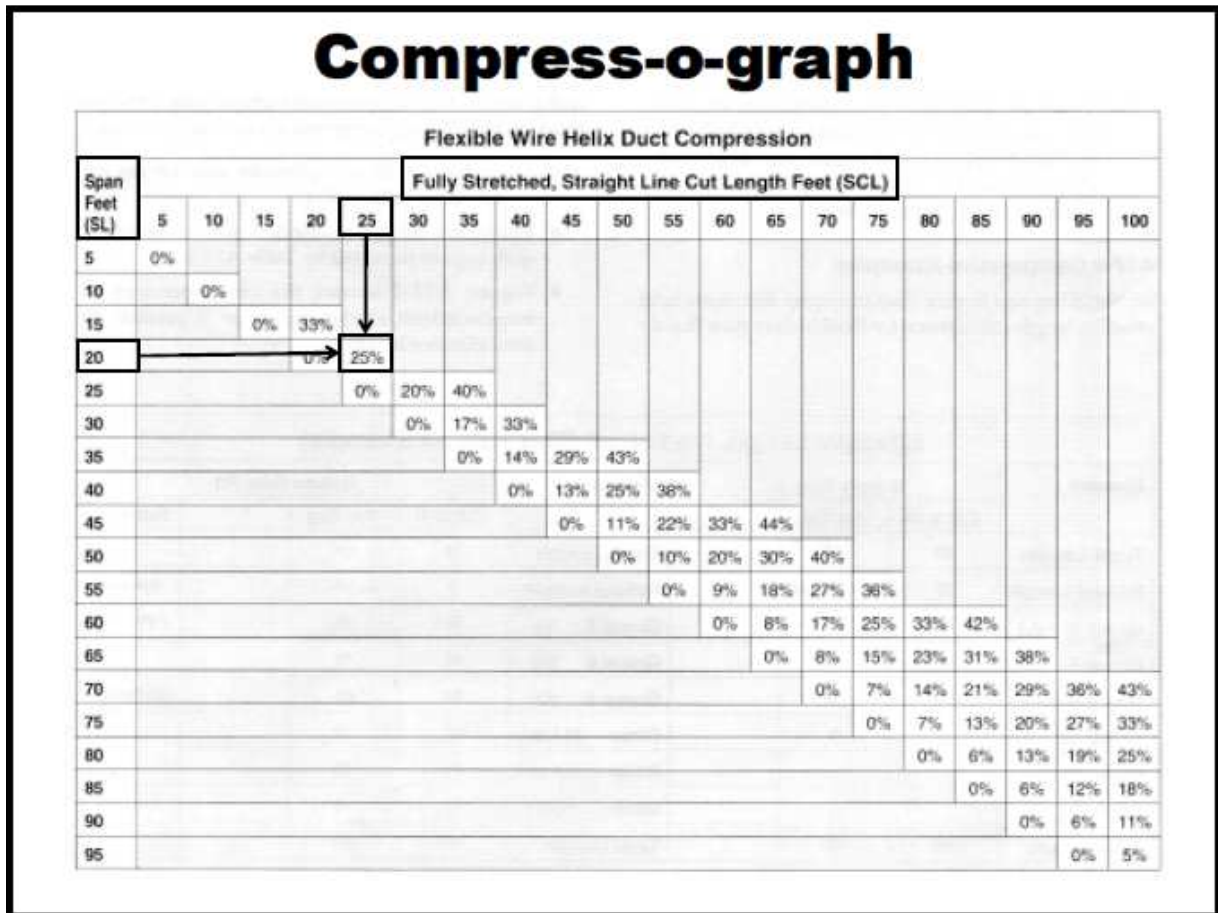

Equivalent Length Multipliers¹ for Wire Helix Duct with Compression and Sag

Compression ?	Superimposed Sag		
	Negligible	1-Inch / Ft	2-Inch / Ft
0% to 4%	1.0		1.1
15%	2.0		2.2
30%	3.4		3.7
45%	5.2		5.7
Bagged	Excess length should not be stored in a bag.		
Coiled	Excess length should not be coiled.		

ACCA Friction Rate Reference Chart

Step 1) Manufacturer's Blower Data

External static pressure (ESP) = _____ IWC CFM = _____

Step 2) Device Pressure Losses

Direct expansion refrigerant coil	_____
Electric resistance heating coil	_____
Hot water coil	_____
Heat exchanger	_____
Low efficiency filter	_____
High or mid-efficiency filter	_____
Electronic filter	_____
Humidifier	_____
Supply outlet	_____
Return grille	_____
Balancing damper	_____
Other device	_____
Total device losses (DPL)	_____

Step 3) Available Static Pressure

ASP = ESP - DPL = (_____ - _____) = _____ IWC

Step 4) Total Effective Length (TEL)

Supply-side TEL + Return-side TEL = (_____ + _____) = _____ FEET

Step 5) Friction Rate Design Value (FR) $\frac{ASP \times 100}{TEL}$

FR value from friction rate chart = _____

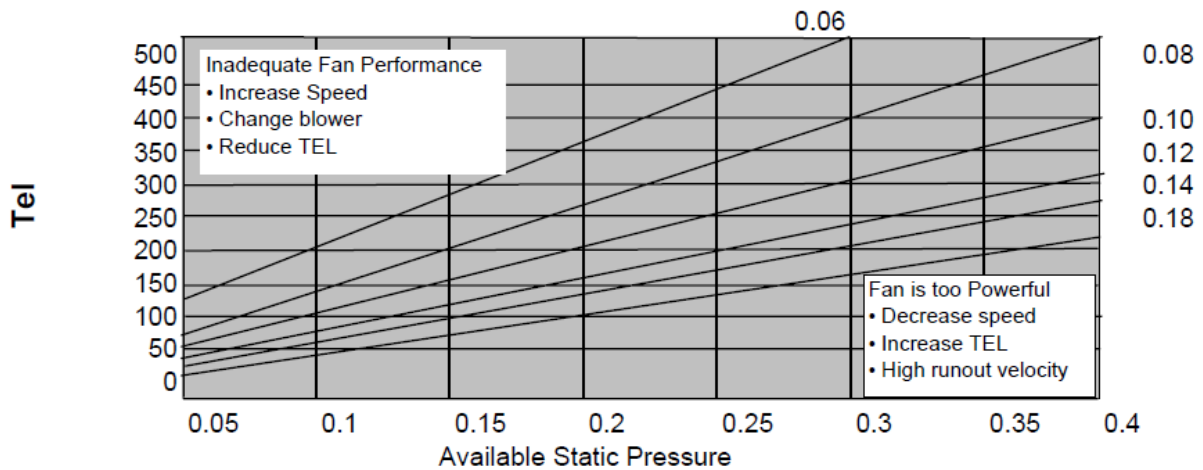

To determine the Required CFM for a particular supply drop, use the following formula;

From the Room to Room Load, obtain the required BTU / Total System Output X 1000 = CFM

Example: 3000 / 28,000 X 1000 = 107 CFM

ACCA Friction Rate Reference Chart

Appendix 3

Group 1
Supply Air Fittings at the Air Handling Equipment
 Reference Velocity = 900 Fpm
 Reference Friction Rate = 0.08 IWC per 100 Feet

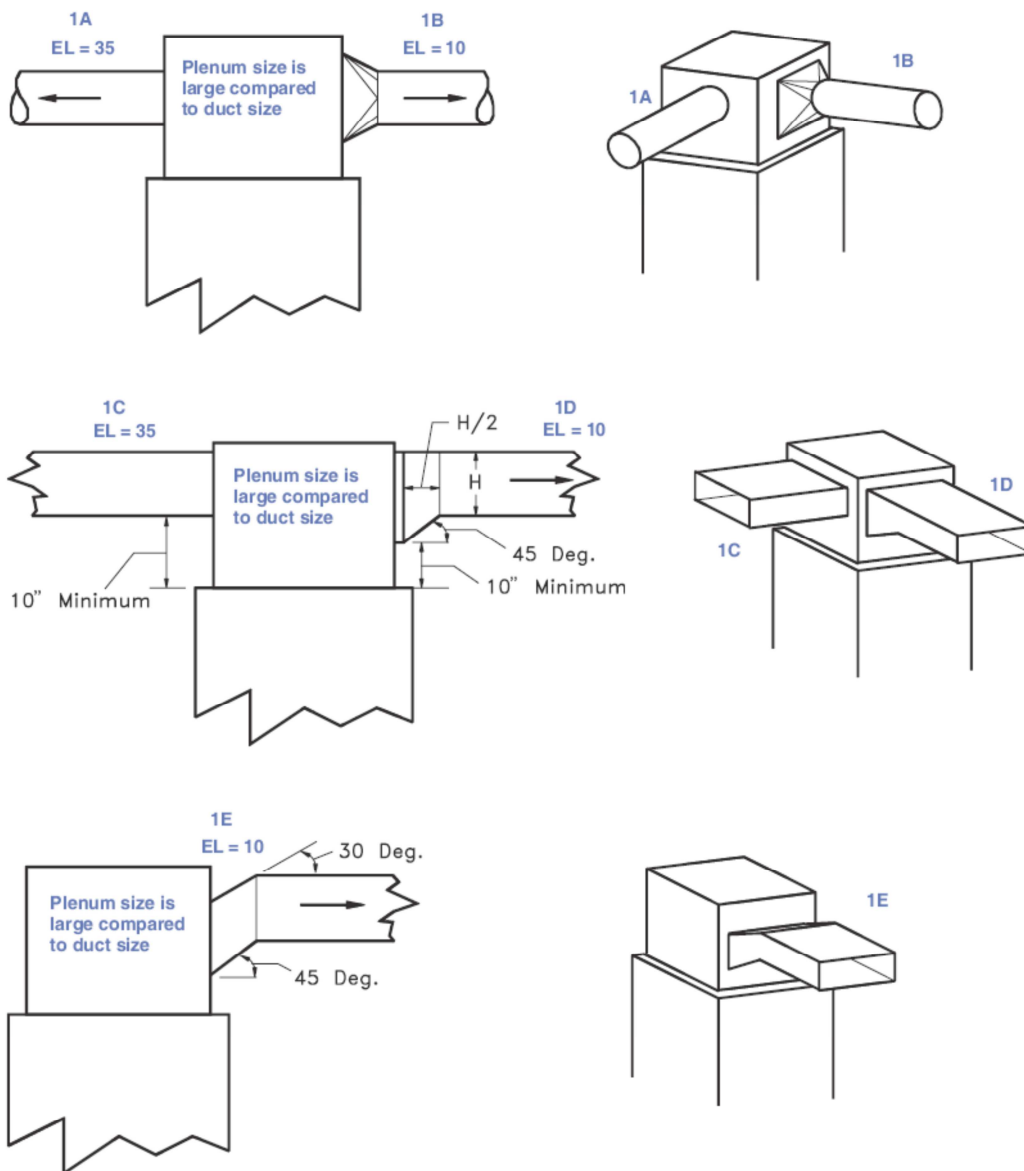

ACCA Friction Rate Reference Chart

Appendix 3

Group 1 — Continued
Supply Air Fittings at the Air Handling Equipment
 Reference Velocity = 900 Fpm
 Reference Friction Rate = 0.08 IWC per 100 Feet

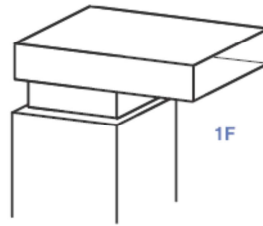
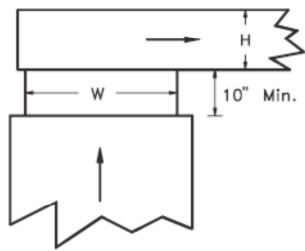

Bull Head 1F	H / W	EL
	0.50	120
	1.0	85

Tapered Head 1G	H / W	EL
	0.50	35
	1.0	25

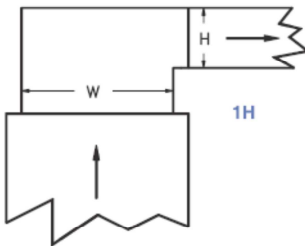
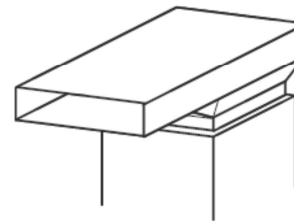
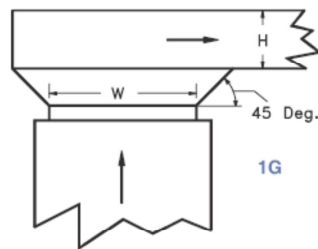

No Vanes 1H	H / W	EL
	0.5	120
	1.0	85

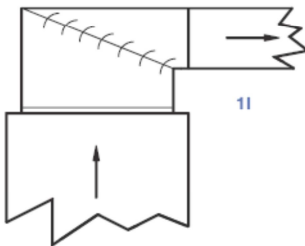
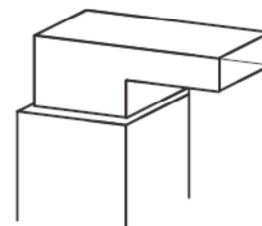

With Vanes 1I	EL = 20

160

ACCA Friction Rate Reference Chart

Appendix 3

Group 1 — Continued
Supply Air Fittings at the Air Handling Equipment
 Reference Velocity = 900 Fpm
 Reference Friction Rate = 0.08 IWC per 100 Feet

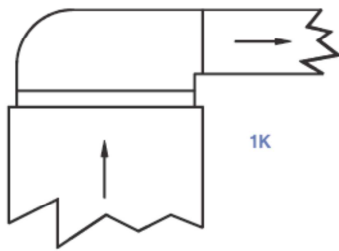

Mitered Inside Corner 1K	EL = 85
-----------------------------------	---------

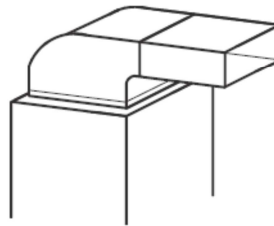
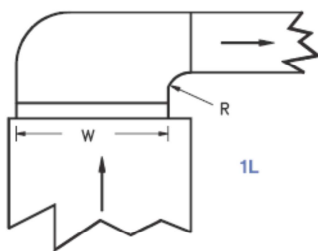

Radius Elbow No Vanes 1L	R / W	EL
	0.25	40
	0.50	20
	1.0	10

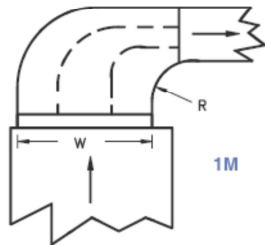

Radius Elbow with Vanes 1M	R / W	1-Vane	2-Vane
		EL	EL
	0.05	30	20
	0.25	20	10
	0.50	10	10

Add the transition EL to
the upstream elbow EL (or
tee EL)

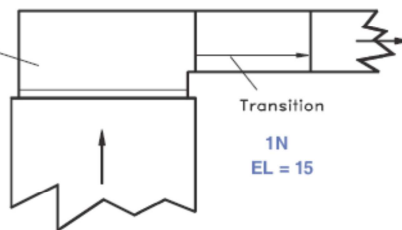

Transition
1N
EL = 15

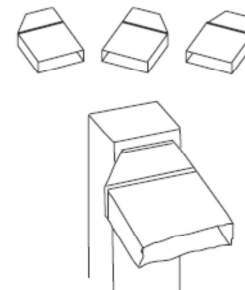

161

ACCA Friction Rate Reference Chart

Appendix 3

Group 1 — Continued
Supply Air Fittings at the Air Handling Equipment
 Reference Velocity = 900 Fpm
 Reference Friction Rate = 0.08 IWC per 100 Feet

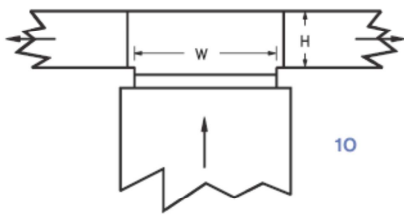

Bull Head No Vanes 10	H / W	EL
	0.50	120
	1.0	85

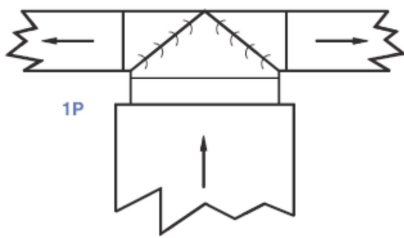
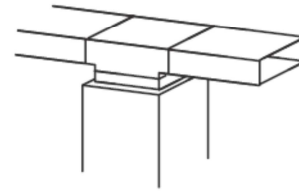

Vaned Tee 1P	EL = 20
-----------------	---------

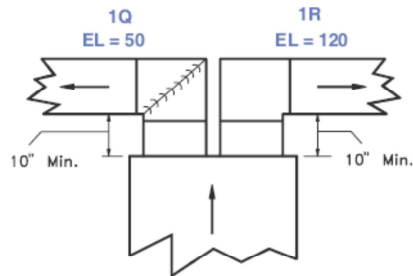
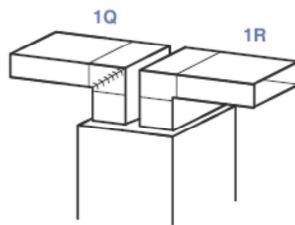

Radius Elbow 1S	Vanes	EL
	0	60
	1	40
	2	30

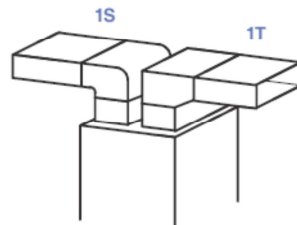
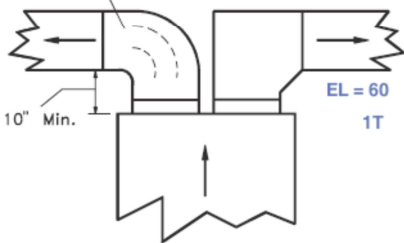







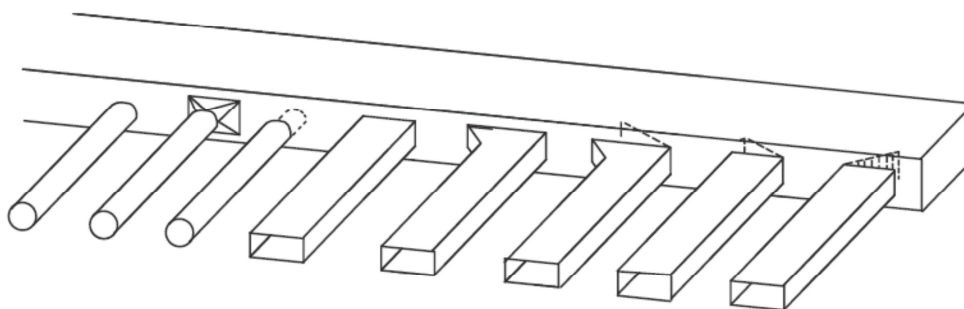

162

ACCA Friction Rate Reference Chart

Appendix 3

Group 2
Branch Takeoff Fittings at the Supply Trunk
 Reference Velocity = 900 Fpm
 Reference Friction Rate = 0.08 IWC per 100 Feet



EL Values		Number of Downstream Branches to End of Trunk Duct or Number of Downstream Branches to a Trunk Reducer					
Fitting		0	1	2	3	4	5 or More
	2A	35	45	55	65	70	80
	2B	20	30	35	40	45	50
	2C	65	65	65	65	70	80
	2D	40	50	60	65	75	85
	2E	25	30	35	40	45	50
	2F	20	20	20	20	25	25
	2G	65	65	65	70	80	90
	2H	70	70	70	75	85	95

Note: If the trunk has a reducer, count down to the reducer; then begin a new count after the reducer.

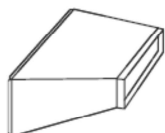

Refer to Fitting 2D

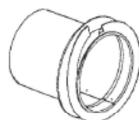

Refer to Fitting 2A or 2C

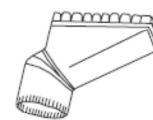





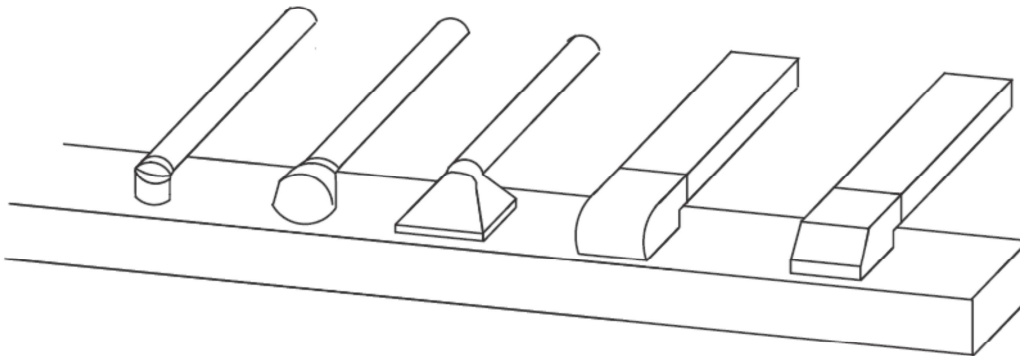

Refer to Fitting 2E

ACCA Friction Rate Reference Chart

Appendix 3

Group 2 — Continued
Branch Takeoff Fittings at the Supply Trunk
 Reference Velocity = 900 Fpm
 Reference Friction Rate = 0.08 IWC per 100 Feet



EL Values		Number of Downstream Branches to End of Trunk Duct or Number of Downstream Branches to a Trunk Reducer					
		0	1	2	3	4	5 or More
Fitting							
	2I	65	75	85	95	100	110
	2J	50	60	65	70	75	80
	2K	50	60	65	70	75	80
	2L	70	80	90	95	105	115
	2M	70	80	90	95	105	115

Note: If the trunk has a reducer, count down to the reducer; then begin a new count after the reducer.



Refer to
Fitting 2J



Refer to
Fitting 2J

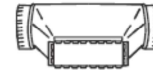





Refer to
Fitting 2I

ACCA Friction Rate Reference Chart

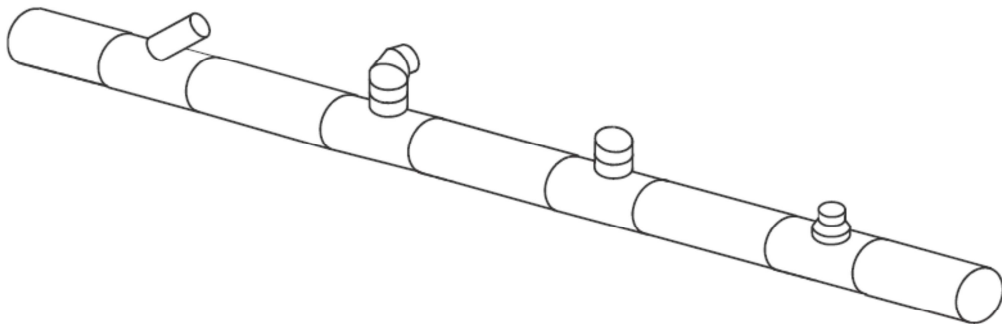
Appendix 3

Group 2 — Continued
Branch Takeoff Fittings at the Supply Trunk
 Reference Velocity = 900 Fpm
 Reference Friction Rate = 0.08 IWC per 100 Feet



EL Values		Number of Downstream Branches to End of Trunk Duct or Number of Downstream Branches to a Trunk Reducer					
		0	1	2	3	4	5 or More
	2N	35	35	40	40	40	40
	2O	55	65	75	85	90	100
	2P	50	55	60	65	70	75
	2Q	10	10	15	20	20	25

Note: If the trunk has a reducer, count down to the reducer; then begin a new count after the reducer.

ACCA Friction Rate Reference Chart

Appendix 3

Group 3
Reducing Trunk Takeoff Fittings
 Reference Velocity = 900 Fpm
 Reference Friction Rate = 0.08 IWC per 100 Feet

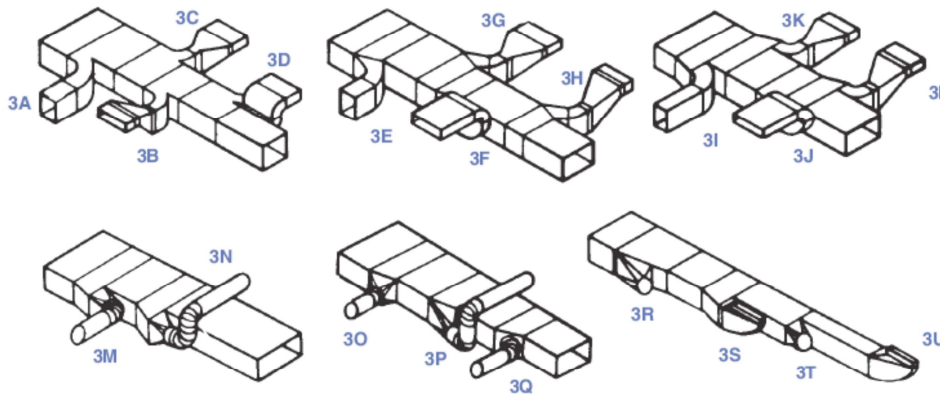

Fitting ID	EL	Description of Assembly
3A and 3I	15	Full radius takeoff
3B and 3L	30	Full radius takeoff plus offset transition
3C and 3K	20	Full radius takeoff plus straight transition
3D and 3J	35	Radius takeoff elbow (see 3S) plus easy-bend elbow
	55	Tight radius takeoff elbow (see 3S) plus easy-bend elbow
	110	Mitered inside corner takeoff elbow (see 3S) plus easy-bend elbow
3E	30	Transition wall takeoff
3F	3D + 15	Transition wall takeoff elbow (radius, tight radius or mitered corner) plus easy-bend elbow
3G	35	Transition wall takeoff plus straight-aspect transition
3H	35	Transition wall takeoff plus offset-aspect transition
3M	25	In line eased takeoff fitting (see 3T) plus one elbow
3N	40	In line eased takeoff fitting (see 3T) plus two elbows
3O and 3R	20	Transition wall eased takeoff fitting (see note)
3P	50	Transition wall eased takeoff fitting plus two elbows (see note)
3Q	35	Transition wall eased takeoff fitting plus one elbow (see note)
3S and 3U	15	Full radius takeoff elbow
	35	Tight inside radius takeoff elbow
	90	Mitered inside corner takeoff elbow
3T	10	In line eased takeoff fitting

Note: Add 15 feet to the equivalent length if a round sleeve is simply butted to the transition wall.

ACCA Friction Rate Reference Chart

Appendix 3

Group 3 — Continued
Reducing Trunk Takeoff Fittings
 Reference Velocity = 900 Fpm
 Reference Friction Rate = 0.08 IWC. per 100 Feet

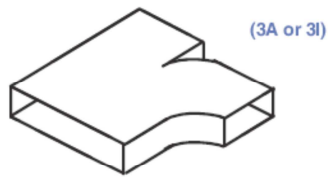

Full Radius Takeoff 3A or 3I	EL = 15
---------------------------------------	---------

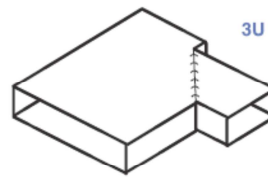

Mitered Takeoff 3U	Vanes	EL
	Yes	10
	No	80

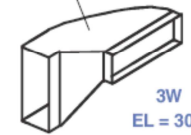
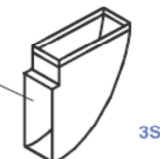
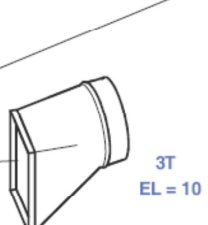
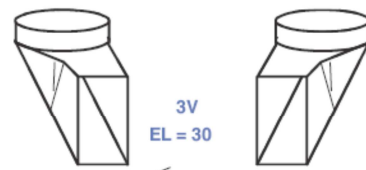
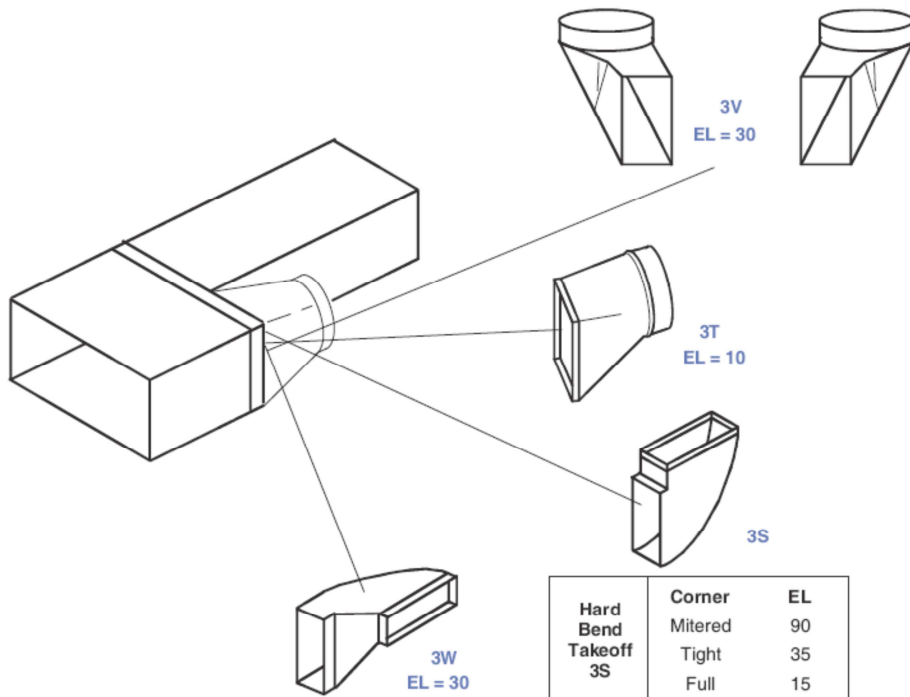

Hard Bend Takeoff 3S	Corner	EL
	Mitered	90
	Tight	35
	Full	15

167

ACCA Friction Rate Reference Chart

Appendix 3

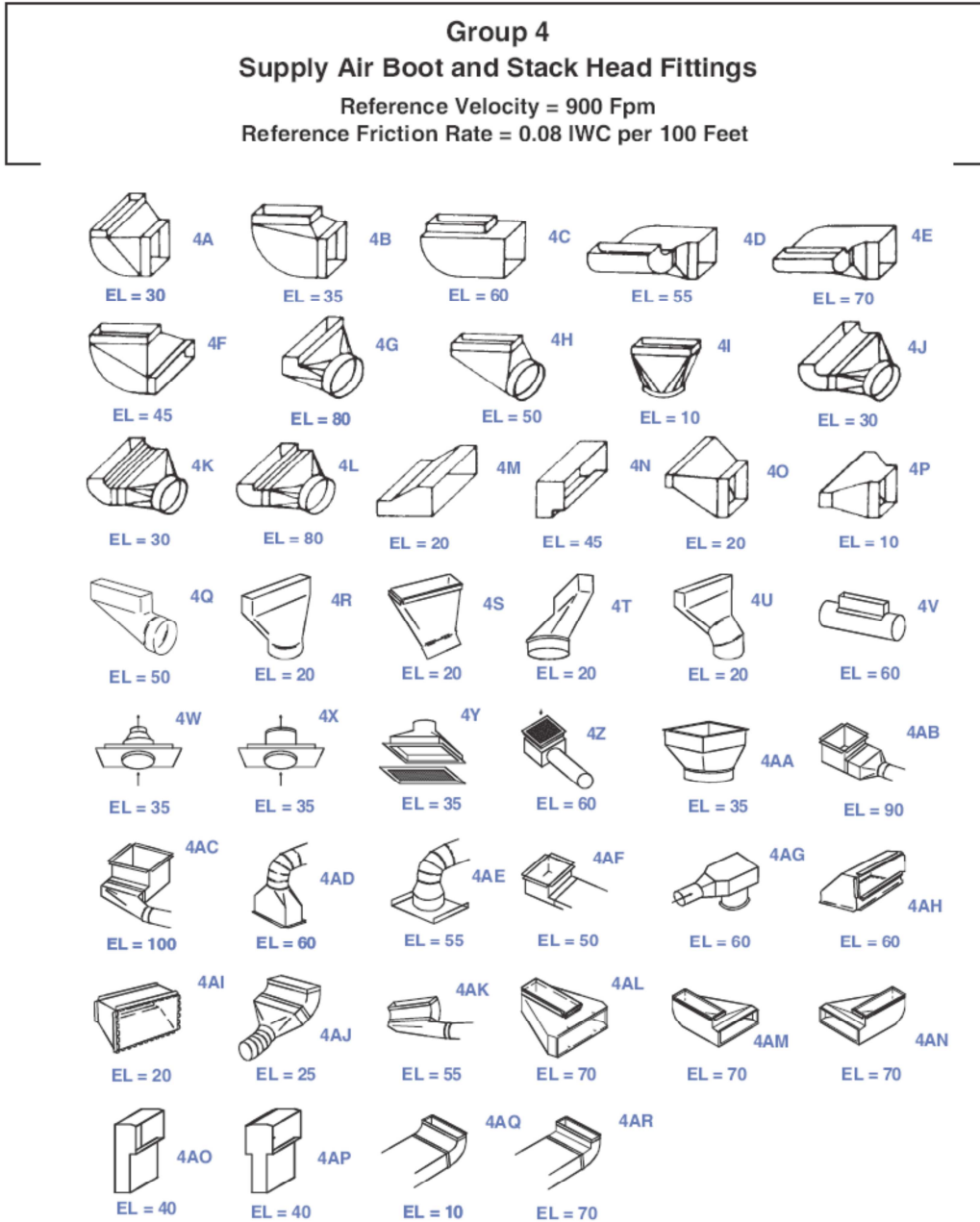

ACCA Friction Rate Reference Chart

Appendix 3

Group 5
Return Air Fittings at the Air Handling Equipment
 Reference Velocity = 700 Fpm
 Reference Friction Rate = 0.08 IWC per 100 Feet

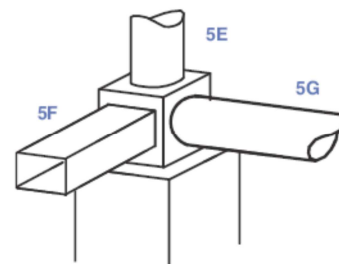
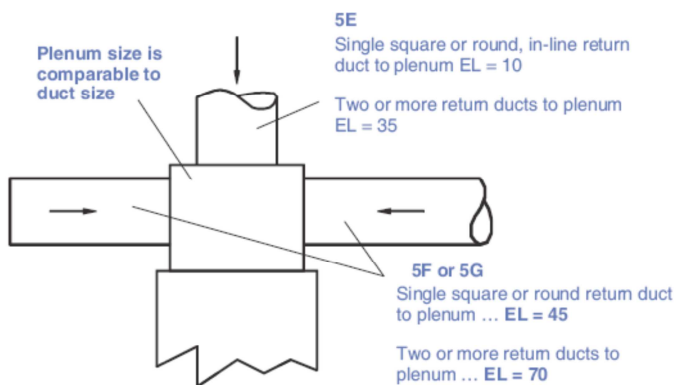
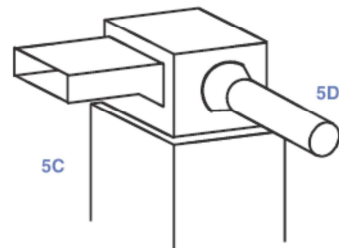
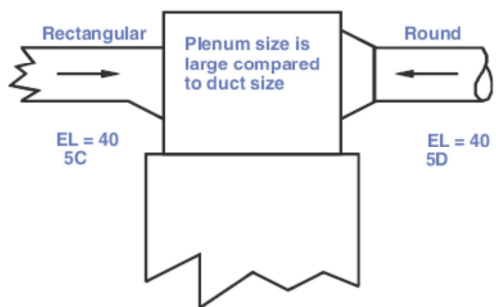
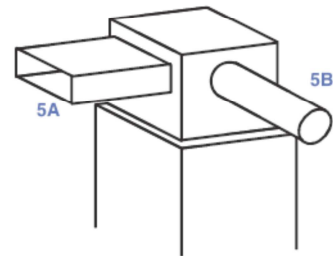
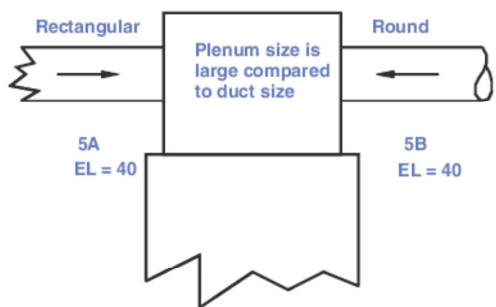

ACCA Friction Rate Reference Chart

Appendix 3

Group 5 — Continued
Return Air Fittings at the Air Handling Equipment
 Reference Velocity = 700 Fpm
 Reference Friction Rate = 0.08 IWC per 100 Feet

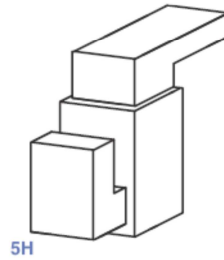
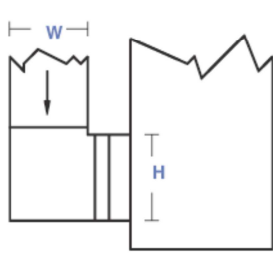

Square Elbow 5H	H / W	EL
	1	45
	2	30

Mitered Inside Corner 5I	H / W	EL
	1	45
	2	30

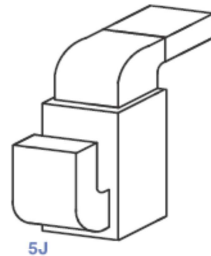
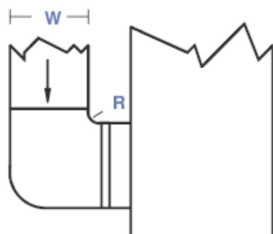
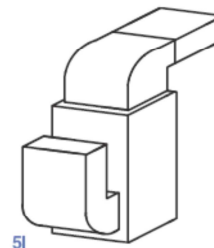
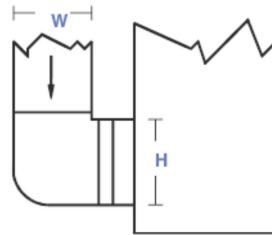

Radius Elbow 5J	R / W	EL
	0.25	20
	0.50	15
	1.00	10

Square Elbow with Vanes 5K	EL
	10

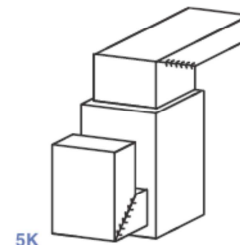
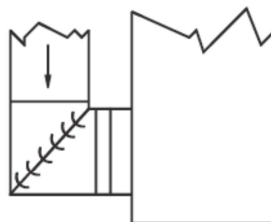

170

ACCA Friction Rate Reference Chart

Appendix 3

Group 5 — Continued
Return Air Fittings at the Air Handling Equipment
Reference Velocity = 700 Fpm
Reference Friction Rate = 0.08 IWC per 100 Feet

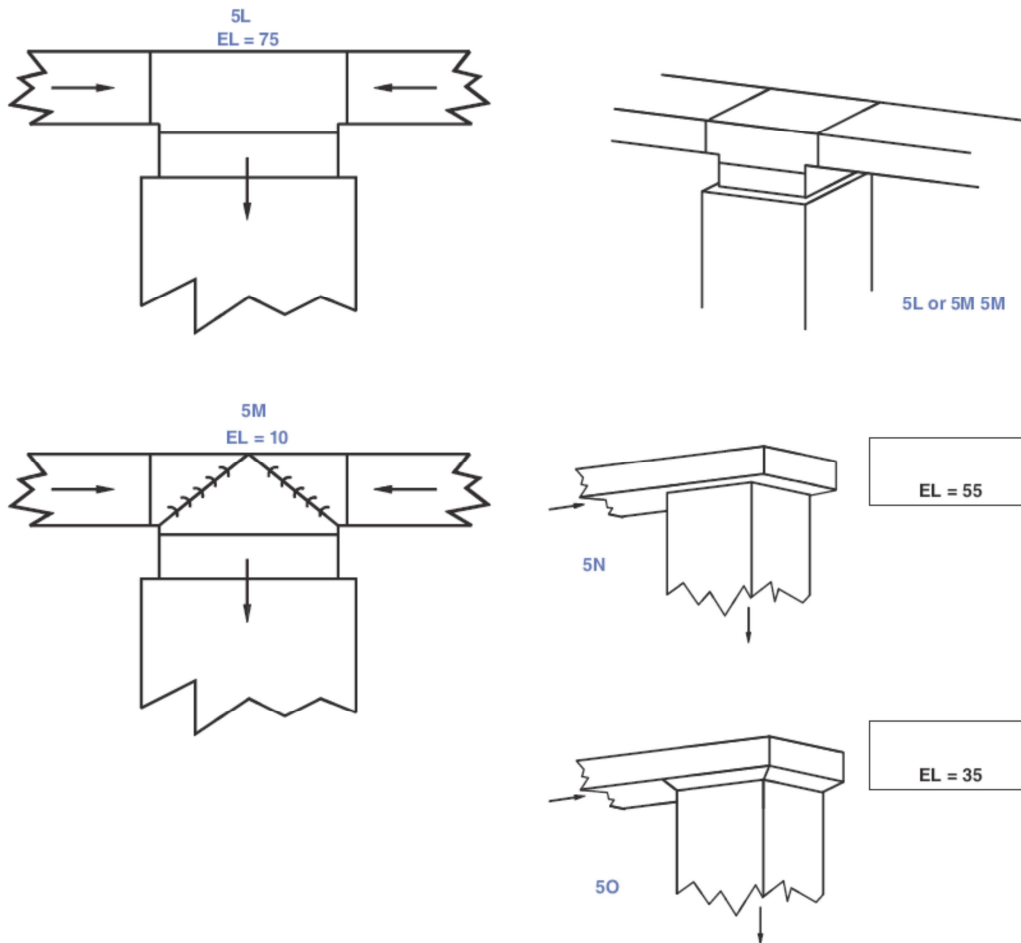

171

ACCA Friction Rate Reference Chart

Appendix 3

Group 6
Branch Return Air Fittings at the Return Trunk
 Reference Velocity = 700 Fpm
 Reference Friction Rate = 0.08 IWC per 100 Feet

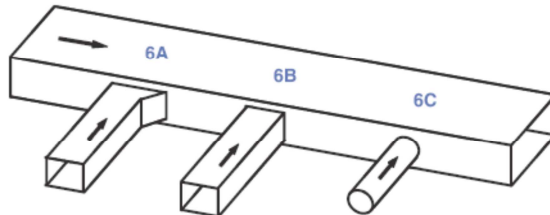

	6A		6B		6C	
	Branch EL	Trunk EL	Branch EL	Trunk EL	Branch EL	Trunk EL
Cfm1/Cfm2						
0.40 or less	10	10	10	10	10	10
0.50	25	25	40	25	30	25
0.60	40	25	40	25	50	25
0.70	60	25	75	25	75	25
0.80	75	25	110	25	115	25
1.00	75	NA	110	NA	115	NA

The branch EL value applies to the turn and the trunk EL value applies to the upstream fittings (see example below).

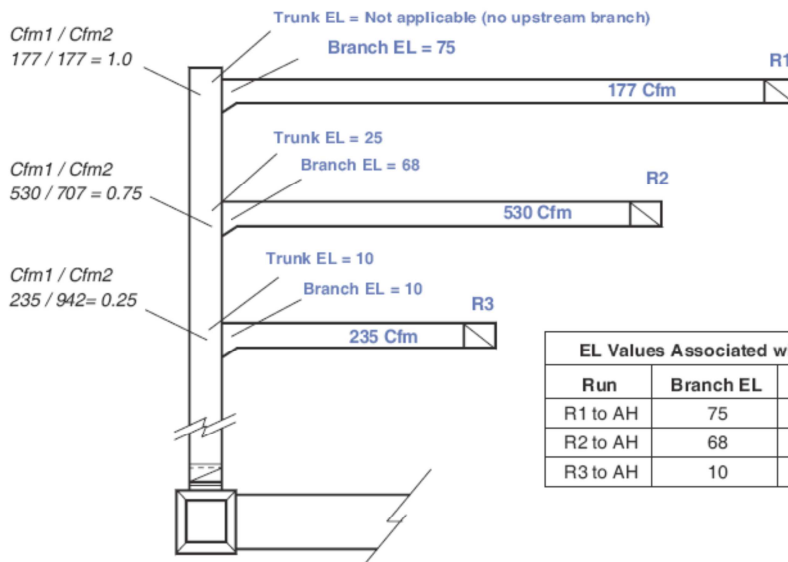

Run	Branch EL	Trunk EL	Total EL
R1 to AH	75	25 + 10	110
R2 to AH	68	10	78
R3 to AH	10	0	10

ACCA Friction Rate Reference Chart

Appendix 3

Group 6 — Continued
Branch Return Air Fittings at the Return Trunk
 Reference Velocity = 700 Fpm
 Reference Friction Rate = 0.08 IWC per 100 Feet

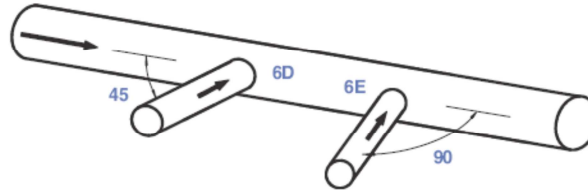

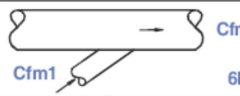
		
	Branch EL	Trunk EL
Cfm1/Cfm2		
0.10	10	5
0.20	15	5
0.30	20	5
0.40	30	5
0.60	30	5
0.80	30	5
1.00	30	NA
Refer to example below		

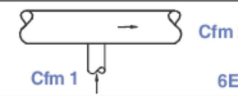
		
	Branch EL	Trunk EL
Cfm1/Cfm2		
0.10	15	10
0.20	30	10
0.30	40	10
0.40	40	10
0.50	40	25
0.80	40	25
1.00	40	NA
Refer to example below		

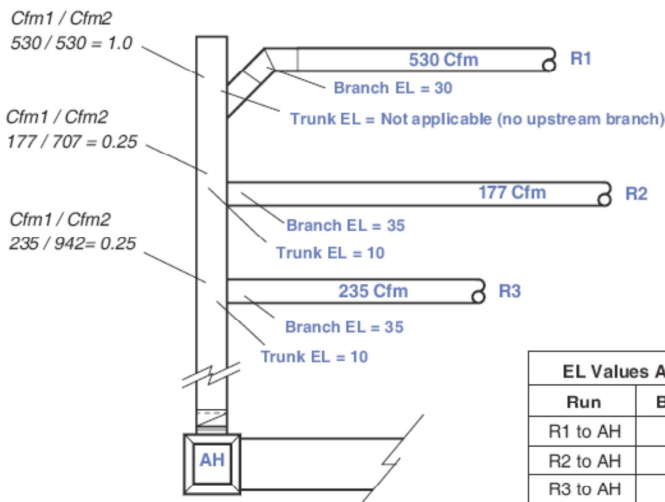

Run	Branch EL	Trunk EL	Total EL
R1 to AH	30	10 + 10	50
R2 to AH	35	10	45
R3 to AH	35	0	35

173

ACCA Friction Rate Reference Chart

Appendix 3

Group 6 — Continued
Return Air Boot Fittings
 Reference Velocity = 700 Fpm
 Reference Friction Rate = 0.08 IWC per 100 Feet

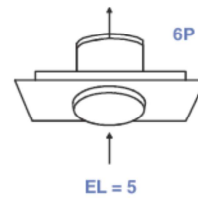
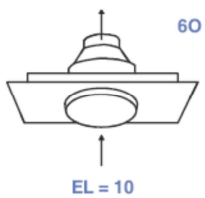
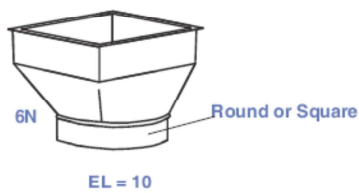
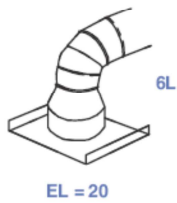
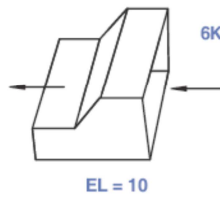
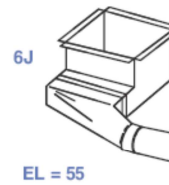
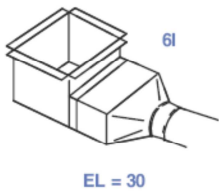
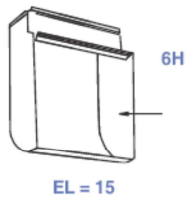
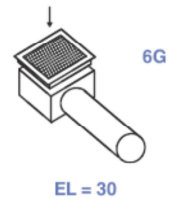
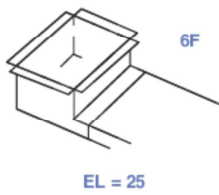

ACCA Friction Rate Reference Chart

Appendix 3

Group 7
Panned Joists and Panned Stud Return Air Fittings
 Reference Velocity = 700 Fpm
 Reference Friction Rate = 0.08 IWC per 100 Feet

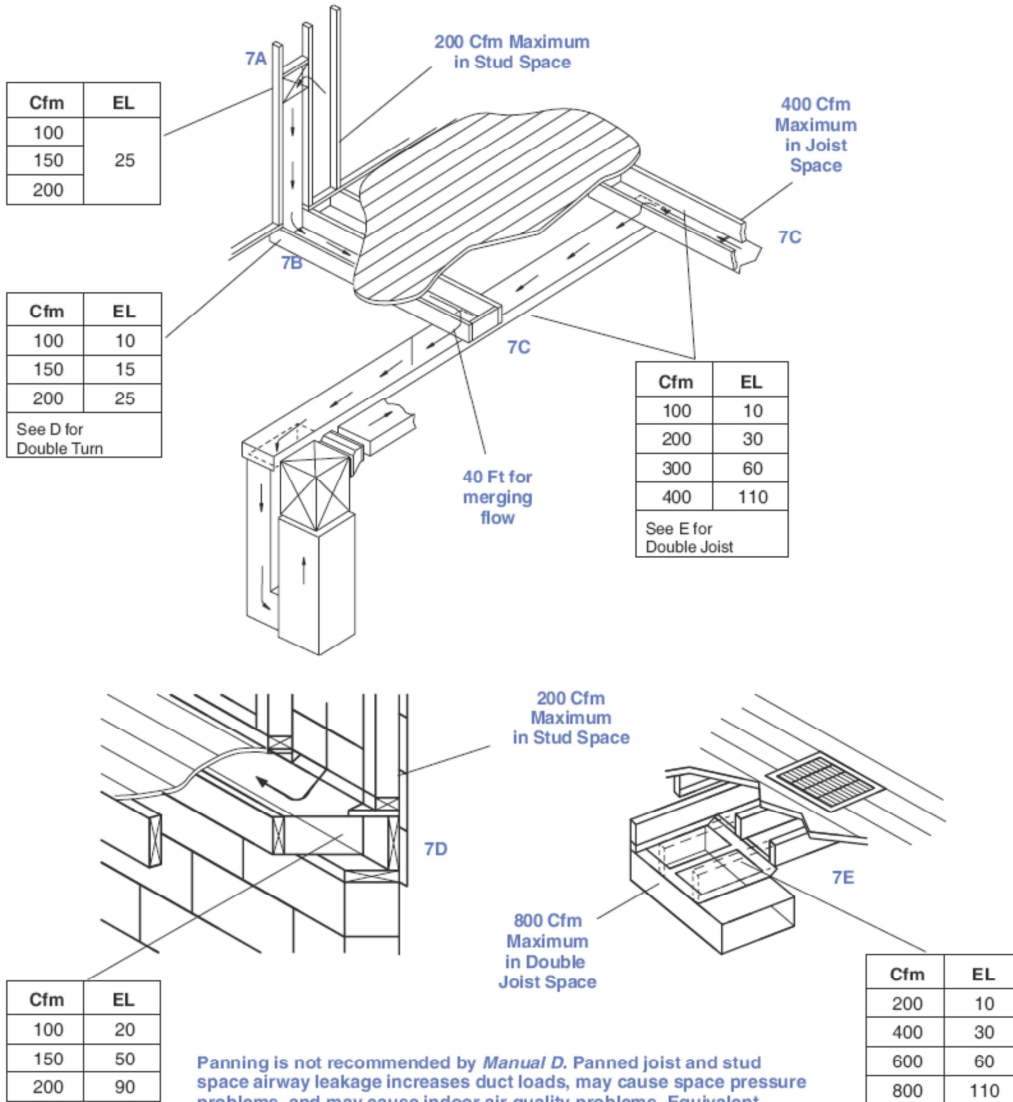









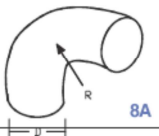





Panning is not recommended by *Manual D*. Panned joist and stud space airway leakage increases duct loads, may cause space pressure problems, and may cause indoor air quality problems. Equivalent length and airway sizing procedures are approximate, and there is no sizing procedure if there are obstructions in the airway. Group 7 equivalent length values are used to evaluate existing systems. See Section 4-5 for more discussion.



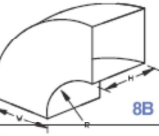

175

ACCA Friction Rate Reference Chart

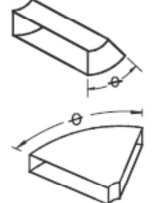
Appendix 3

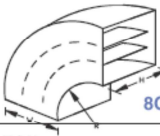
Group 8 Elbows and Offsets Reference Velocity = 900 Fpm Reference Friction Rate = 0.08 IWC per 100 Feet								
	Round and Oval Elbow EL Values							
								
R/D	Smooth	4 or 5 Piece	3 Piece	Smooth Mitered	Easy Bend	Hard Bend	3-Piece 45°	2-Piece 45°
Mitered (R = 0)	—	—	—	75	4-Piece 25	4-Piece 30	10	15
0.75	20	30	35	—	3-Piece 30	3-Piece 35		
1.0	15	20	25	—	—	—		
1.5 or Larger	10	15	20	—	—	—		
	For Smooth Radius Round Elbows Angles (θ) Less Than 90° Multiply EL by One of the Following Factors							
	20°	30°	45°	60°	75°	110°	130°	150°
	0.31	0.45	0.60	0.78	0.90	1.13	1.20	1.28



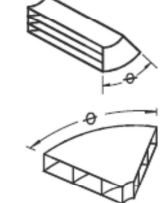

	Radius Elbow EL Values		
			
R/W	Hard Bend	H / W = 1	Easy Bend
Mitered (R = 0)	90	75	65
0.25	35	30	25
0.5 or Larger	20	15	10
	For Angles (θ) Less Than 90° Multiply EL by One of the Following Factors		
	30°	45°	60°
	0.45	0.60	0.78



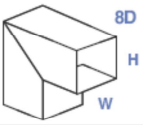

	Radius Elbow EL Values		
			
R/W	Hard Bend	H / W = 1	Easy Bend
Mitered (R = 0)	30	25	40
0.25	10	10	10
0.5 or Larger	5	5	5
	For Angles (θ) Less Than 90° Multiply EL by One of the Following Factors		
	30°	45°	60°
	0.45	0.60	0.78

ACCA Friction Rate Reference Chart

Appendix 3

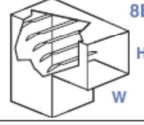
Group 8 — Continued
Elbows and Offsets
 Reference Velocity = 900 Fpm
 Reference Friction Rate = 0.08 IWC per 100 Feet

8D 	Square Elbow EL Values		
			
No Vanes	80	80	65

8E 	Square Elbow EL Values		
			
Single Thickness Turning Vanes	10	10	10

L/H	EL
1	160
2	260
4	190

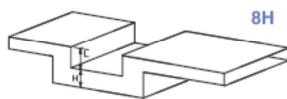
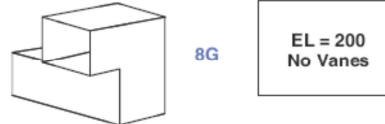
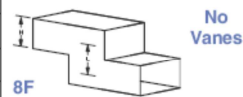

EL's H/L	No Vanes	With Vanes
0.5	55	—
1.0	330	55
1.5	430	55
2.0	470	55

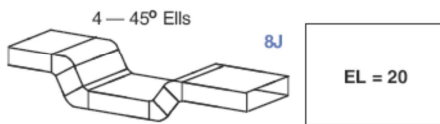
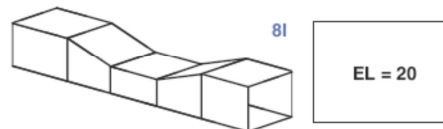

R/H	EL
Mitered (R=0)	250
0.25	100
0.50	20
1.00	20

R = Inside radius
H = Duct height

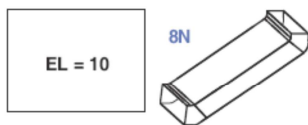
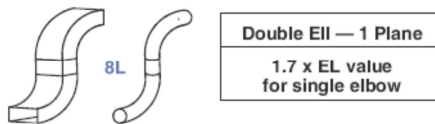

Inside Corner	EL
Miter (R=0)	235
R = 0.25	90
R > 0.50	45

EL Values	Inside Corners		
	Riser	Miter	Radius
3-1/4 x 10	75	60	
3-1/4 x 12	90	75	
3-1/4 x 14	90	75	

177

ACCA Friction Rate Reference Chart

Appendix 3

Group 9
Supply Trunk Junction Fittings
 Reference Velocity = 900 Fpm
 Reference Friction Rate = 0.08 IWC per 100 Feet

The equivalent lengths in this group apply when the flow in a secondary trunk duct is a substantial percentage of the flow in the upstream (primary) duct. See Group 2, Branch Takeoff Fittings for branch runout equivalent length values.

	EL
Branch	35
Main	5

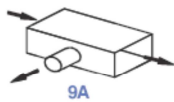
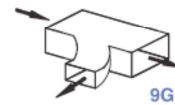

	EL
Branch	80
Main	5

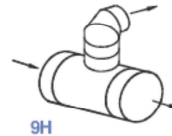

	EL
Branch	100
Main	5

	EL
Branch	80
Main	5

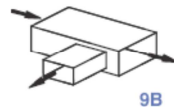

	EL
Branch	85
Main	5

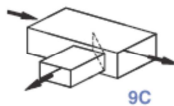
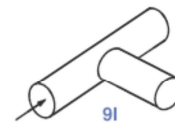

	EL
Branch	80
Main	5

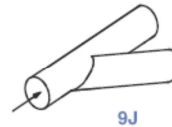

	EL
Branch	25
Main	5

	EL
Branch	75
Main	5

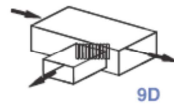

EL = 65	
---------	--

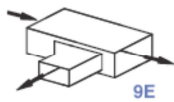
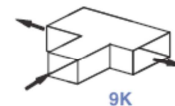

	EL
Branch	50
Main	5

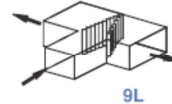

EL = 20	
---------	--

	EL
Branch	45
Main	5

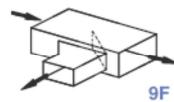

EL = 20	
---------	--

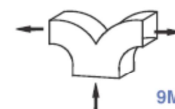

ACCA Friction Rate Reference Chart

Appendix 3

Group 9 — Continued
Supply Trunk Junction Fittings
 Reference Velocity = 900 Fpm
 Reference Friction Rate = 0.08 IWC per 100 Feet

The equivalent lengths in this group apply when the flow in a secondary trunk duct is a substantial percentage of the flow in the upstream (primary) duct. See Group 2, Branch Takeoff Fittings for branch runout equivalent length values.

EL = 70

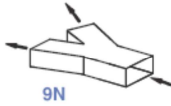
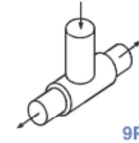

EL = 15

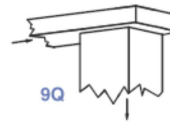

EL = 55

EL = 15

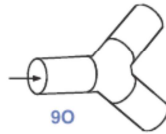

EL = 35

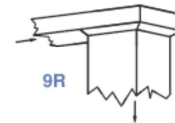

ACCA Friction Rate Reference Chart

Appendix 3

Group 10
Return Trunk Junction Fittings
 Reference Velocity = 700 Fpm
 Reference Friction Rate = 0.08 IWC per 100 Feet

The equivalent lengths in this group apply when the flow in two return trunks merge. See Group 6, Branch Return Fittings, for branch return equivalent length values.

EL = 25

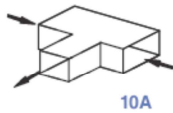
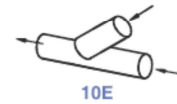

EL = 75

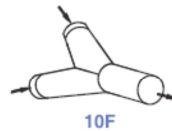

EL = 35

EL = 10

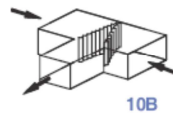

EL = 75

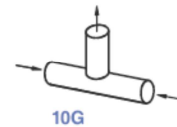

EL = 10

EL = 25

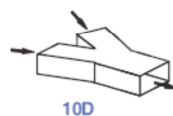

ACCA Friction Rate Reference Chart

Appendix 3

Group 11
Flexible Duct Junction Boxes and Radius Bends
 Reference Velocity = As Indicated
 Reference Friction Rate = 0.08 IWC per 100 Feet

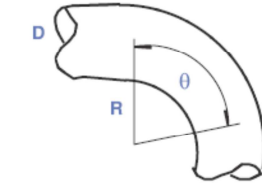
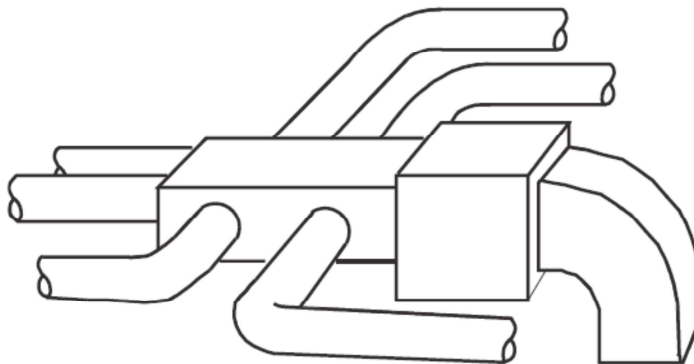

For bends that are not equal to 90°, multiply the 90° equivalent length by the ratio of the desired angle to the 90° angle.

Example: IF R/D = 1.0, find the EL for a 45° bend if the velocity equals 700 Fpm.

$$15 \times 45 / 90 = 7.5 \text{ Ft}$$

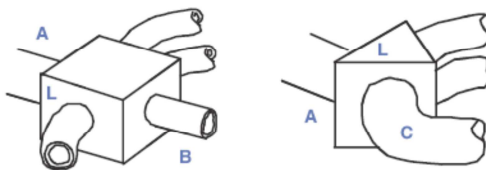

- Recommended** (compatible with Group 11 EL values)
- Entrance (A) has a diffuser fitting that recovers velocity pressures and prevents swirl (optional).
 - Straight approach(A) and straight exit (B)
 - Exit opening on side (no top or bottom exits)
 - Exit opening at least two diameters from entrance (L)
 - Make box as small as possible, but comply with $L = 2 \times D$
- Not Recommended** (Group 11 EL values may be too small)
- Turn or bend near entrance or exit (C).
 - Top or bottom exits <-tentative, may be deleted after investigation
 - Exit opening less than two diameters from entrance (L)

Equivalent Length Values					
Velocity in Flex Duct (Fpm)	Junction Box (Ft) Notes 1, 2 and 3	90° Bend (Ft)			
		R / D Ratio (In / In) ⁴			
		1.0	1.5	2 to 3	4 to 5
400	20	5	5	5	5
500	30	5	5	5	5
600	40	10	5	5	5
700	60	15	10	5	5
800	75	15	10	10	8
900	95	20	15	10	8

1) No anti-swirl regain diffuser at entrance.

- Swirl tends to feed one side of the box and starve the other side.
- Swirl may be induced by spiral wire geometry.
- Swirl attributes (such as direction) may change when the blower shuts down and restarts.

2) Straight-run approach and a straight-run departures (no turns in duct runs near the junction box).

3) Entrance and exits on side of box (no top or bottom openings).

4) Radius of turn divided by diameter of duct.

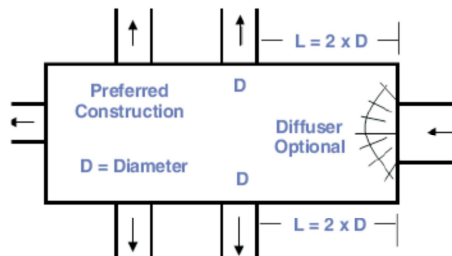

181

ACCA Friction Rate Reference Chart

Appendix 3

Group 12
Transitions (Diverging)
 Reference Velocity = 900 Fpm
 Reference Friction Rate = 0.08 IWC per 100 Feet

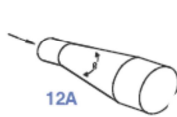

12A

EL Values	A1/A2	A1/A2
Slope	2	4
1:1	20	40
2:1	20	40
4:1	20	30



12F

EL Values	A1/A2	A1/A2
Slope	2	4
1:1	20	40
2:1	20	40
4:1	15	30

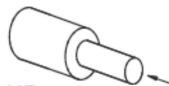

12B

EL Values	A1/A2	A1/A2
Slope	2	4
Abrupt	20	40



12G

EL Values	A1/A2	A1/A2
Slope	2	4
Abrupt	20	40

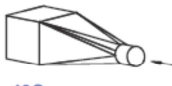

12C

EL Values	A1/A2	A1/A2
Slope	2	4
1:1	20	40
2:1	20	40
4:1	20	30

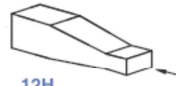

12H

EL Values	A1/A2	A1/A2
Slope	2	4
1:1	20	40
2:1	20	40
4:1	15	25

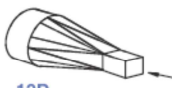

12D

EL Values	A1/A2	A1/A2
Slope	2	4
1:1	20	40
2:1	20	40
4:1	20	30

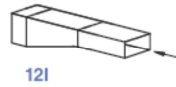

12I

EL Values	A1/A2	A1/A2
Slope	2	4
1:1	20	35
2:1	15	25
4:1	10	10



12E

EL = 25

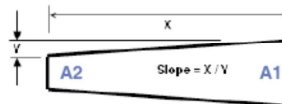

A1 / A2 = Larger Area / Smaller Area

ACCA Friction Rate Reference Chart

Appendix 3

**Group 12
Transitions (Converging)**
Reference Velocity = 900 Fpm
Reference Friction Rate = 0.08 IWC per 100 Feet



12J

EL Values	A1/A2	A1/A2
Slope	2	4
1:1	10	10
2:1	5	5
4:1	5	5

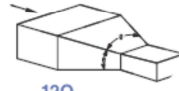

12O

EL Values	A1/A2	A1/A2
Slope	2	4
1:1	10	10
2:1	5	5
4:1	5	5



12K

EL Values	A1/A2	A1/A2
Slope	2	4
Abrupt	25	25



12P

EL Values	A1/A2	A1/A2
Slope	2	4
Abrupt	30	30



12L

EL Values	A1/A2	A1/A2
Slope	2	4
1:1	10	10
2:1	5	5
4:1	5	5

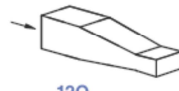

12Q

EL Values	A1/A2	A1/A2
Slope	2	4
1:1	10	10
2:1	5	5
4:1	5	5



12M

EL Values	A1/A2	A1/A2
Slope	2	4
1:1	10	10
2:1	5	5
4:1	5	5

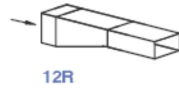

12R

EL Values	A1/A2	A1/A2
Slope	2	4
1:1	5	5
2:1	5	5
4:1	5	5

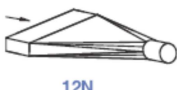

12N

EL = 10

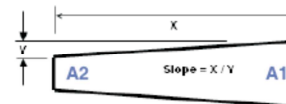

A1 / A2 = Larger Area / Smaller Area

ACCA Friction Rate Reference Chart

Appendix 3

Group 12
Oval Transition Plenums and Abrupt Squeezes
 Reference Velocity = 900 Fpm or as Indicated
 Reference Friction Rate = 0.08 IWC per 100 Feet



EL = 30

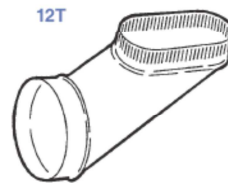

EL = 30

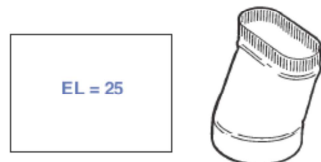

EL = 25

12U

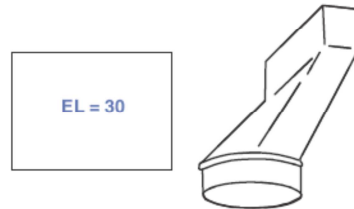

EL = 30

12V



12W

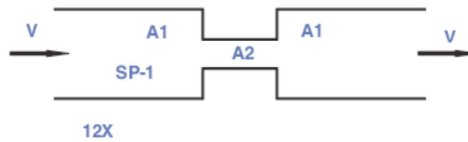

12X

EL Values for Flow Through Large Plenum				
V _{out} (Fpm)	V _{in} (Fpm)			
	600	700	800	900
600	40	40	35	35
700	55	55	50	50
800	70	70	70	65
900	90	90	90	85

Abrupt Squeeze				
Velocity (Fpm)	A1 / A2 = 2		A1 / A2 = 4	
	EL	Min SP-1	EL	Min SP-1
600	65	0.12	245	0.52
700	90	0.16	330	0.71
800	115	0.20	430	0.92
900	145	0.26	545	1.17

Min SP-1 = Minimum upstream static pressure (IWC) for positive static pressure at A2 (air velocity doubles or quadruples at A2).

ACCA Friction Rate Reference Chart

Appendix 3

Group 13
Manual Balancing Dampers
Reference Velocity = 900 Fpm
(Damper Blade in Wide Open Position)

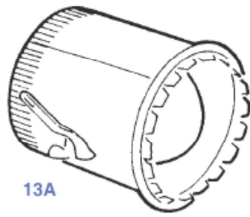

13A

Device
Pressure Loss
0.03 IWC

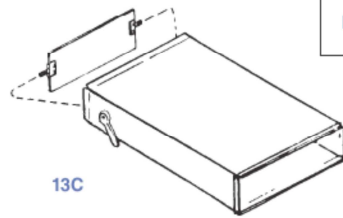

13C

Device
Pressure Loss
0.03 IWC

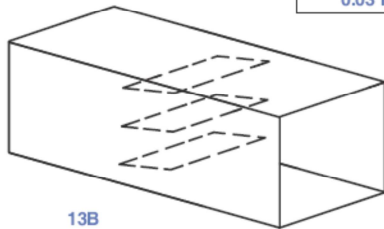

13B

Device
Pressure Loss
0.03 IWC

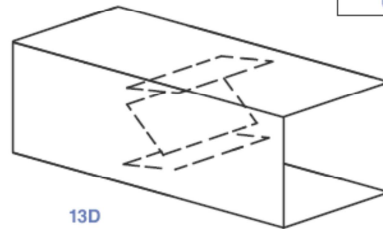

13D

Device
Pressure Loss
0.03 IWC