



ENGINEERING DATA

LG
L SERIES® ROOFTOP UNITS
60 HZ

Bulletin No. 210410
August 2007
Supersedes June 2006



ASHRAE 90.1
COMPLIANT



13 to 25 Tons
Net Cooling Capacity - 154,000 to 286,000 Btuh
Gas Input Heat Capacity - 169,000 to 480,000 Btuh

MODEL NUMBER IDENTIFICATION

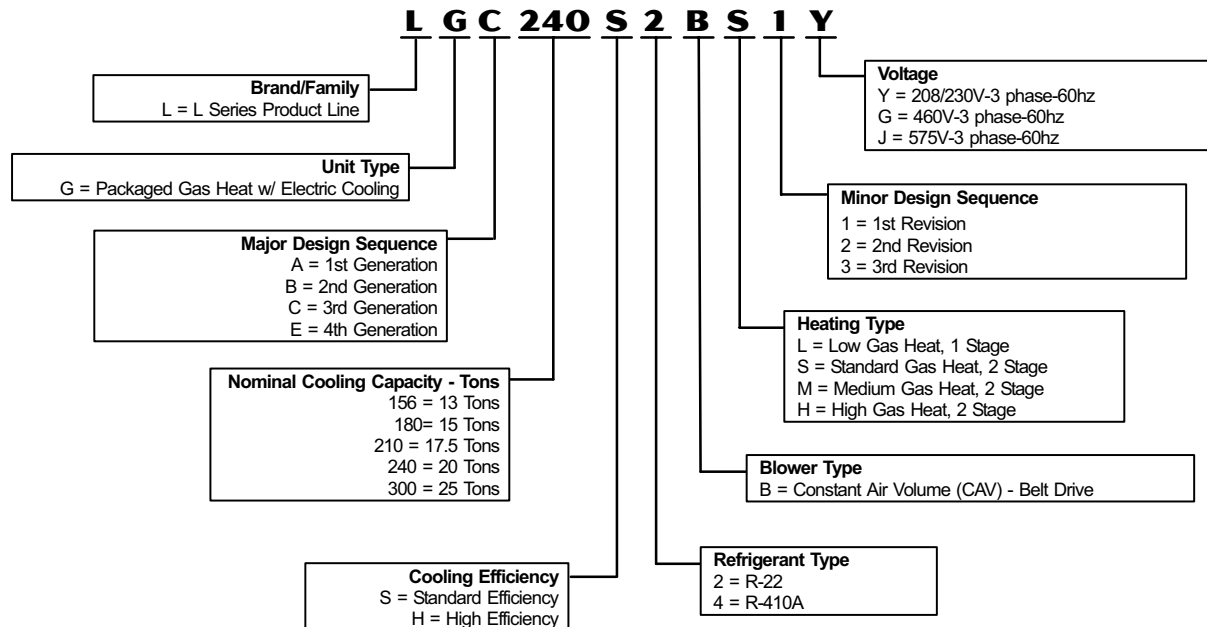

TABLE OF CONTENTS

Application Guide - Controls	Pages 69-71
Blower Data	Pages 31-37
Control Systems	Pages 44-52
Cooling Ratings	Pages 19-25
Dimensions	Pages 54-60
Electrical Data	Pages 38-42
Features and Benefits	Pages 2-6
Guide Specifications	Pages 61-68
High Altitude Information	Page 31
Humiditrol® Condenser Reheat Option	Page 8
Humiditrol® Condenser Reheat Ratings	Pages 25-30
Model Number Identification	Page 1
Options / Accessories	Pages 7-12
Specifications	Pages 13-17
Sound Data	Page 42
Unit Clearances	Page 43
Weight Data	Page 53

FEATURES AND BENEFITS

APPROVALS

ETL and CSA listed.

Heating efficiency ratings verified by CSA.

Components bonded for grounding to meet safety standards for servicing required by UL, CSA and National and Canadian Electrical Codes.

156 thru 240 models are certified in accordance with the ULE certification program, which is based on ARI Standard 340/360-2004.

300 models are tested at conditions included in ARI Standard 340/360-2004.

ENERGY STAR® certified units are designed to use less energy, help save money on utility bills, and help protect the environment.

The ENERGY STAR® Partner of the Year Award signifies that Lennox has made outstanding contributions to design energy efficient units that will lower energy bills, while meeting industry standards for comfort and indoor air quality. Lennox was the first HVAC manufacturer to win this award and has been a four-time recipient since 2003. ISO 9001 Registered Manufacturing Quality System.

Dealer Design Award

Lennox has received the Dealer Design Award from an independent panel of dealer-contractors selected by Air Conditioning, Heating & Refrigeration News ("The News") magazine. Their decision is based on "best in categories" of installation, maintenance and service as well as quality and performance.

WARRANTY

Limited ten years aluminized heat exchanger, limited fifteen years optional stainless steel heat exchanger.

Limited five years on compressors.

Limited three years on Integrated Modular Control.

Limited one year all other covered components.

COOLING SYSTEM

Designed to maximize sensible and latent cooling performance at design conditions.

Two efficiency levels provide flexibility.

System can operate from 0°F to 125°F without any additional controls.

1 Compressors

Resiliently mounted on rubber grommets for quiet operation.

Scroll compressors on all models for high performance, reliability and quiet operation.

Compressor Crankcase Heaters

Protects against refrigerant migration that can occur during low ambient operation.

2 Thermal Expansion Valves

Assures optimal performance throughout the application range.

Removable element head.

3 Filter/Driers

High capacity filter/driers protect the system from dirt and moisture.

4 High Pressure Switches

Protects the compressor from overload conditions such as dirty condenser coils, blocked refrigerant flow, or loss of outdoor fan operation. Automatic reset

Low Pressure Switches

Protects the compressor from low pressure conditions such as low refrigerant charge, or low/no air flow. Automatic reset

Freezestats

Protects the evaporator coil from damaging ice build-up due to conditions such as low/no air flow, or low/no refrigerant charge.

5 Coil Construction

Copper tube construction, enhanced rippled-edge aluminum fins, flared shoulder tubing connections, silver soldered construction for improved heat transfer. Factory leak tested.

Evaporator Coil

Face-split coil. Cross row circuiting with rifled copper tubing optimizes both sensible and latent cooling capacity. Low fin per inch count minimizes air pressure drop.

Condenser Coil

Angled, slab design helps protect coil from possible contact or hail damage.

Condensate Drain Pan

Drain connection extends outside unit.

Painted, galvanized pan with positive slope.

Stainless steel drain pan available as a factory installed option.

6 Outdoor Coil Fan Motors

Thermal overload protected, totally enclosed, permanently lubricated ball bearings, shaft up, wire basket mount.

Outdoor Coil Fan

PVC coated fan guard furnished.

Refrigerant Choice

R-22 or R-410A refrigerant

REQUIRED SELECTIONS

Cooling Capacity

Specify the nominal cooling capacity of the unit

Cooling Efficiency

Specify either standard or high efficiency.

Refrigerant Choice

Specify R-22 or R-410A refrigerant.

FEATURES AND BENEFITS

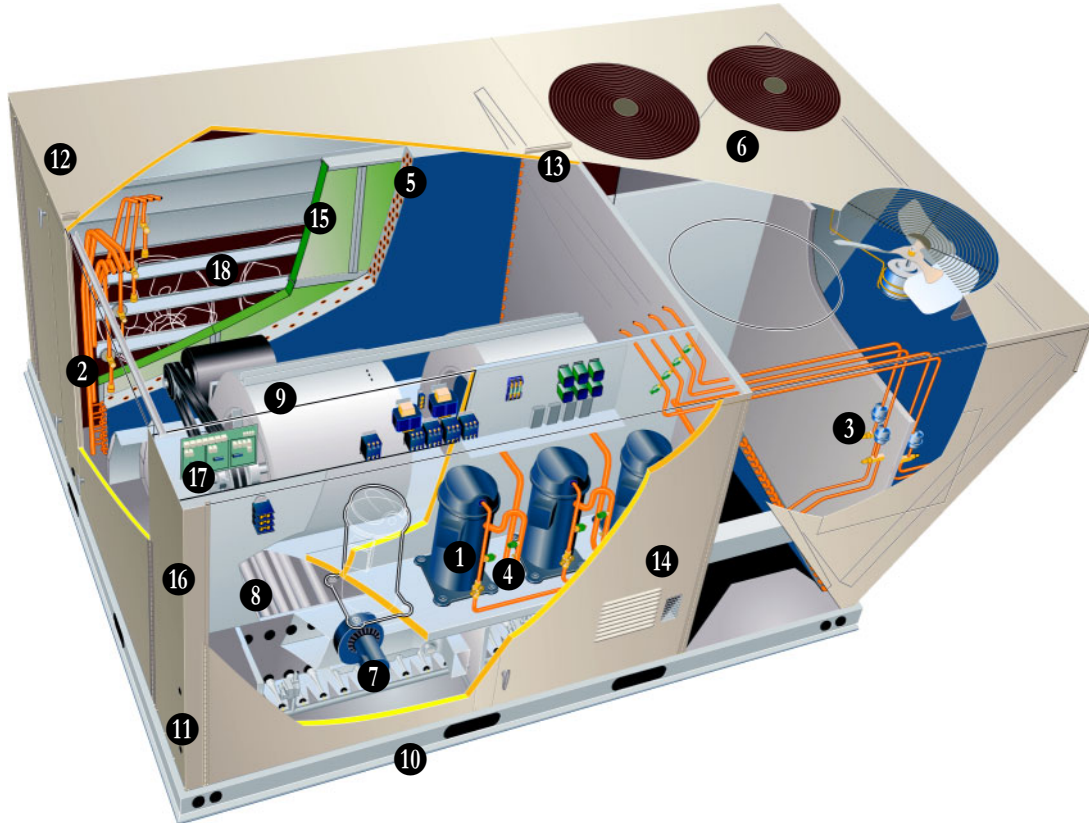

COOLING SYSTEM - CONT.

OPTIONS / ACCESSORIES

Factory Installed

Fresh Air Tempering

Provides heating and cooling as needed to maintain the supply air temperature within a comfort range, regardless of the thermostat demand. Sensor ships with unit but must be field installed in the supply air duct. Requires change to IMC (Integrated Modular Control) (ECTO) parameter in the field to activate this mode of operation.

Service Valves

Fully serviceable brass valves installed in discharge & liquid lines. Not for use with Humiditrol equipped units.

Stainless Steel Condensate Drain Pan

Factory installed

Factory or Field Installed

Condensate Drain Trap

Field installed only, may be factory enclosed to ship with unit. Available in copper or PVC.

HEATING SYSTEM

7 Aluminized steel inshot burners, direct spark ignition, electronic flame sensor, combustion air inducer, redundant automatic single or dual stage gas valve with manual shut-off.

8 Heat Exchanger

Tubular construction, aluminized steel, life cycle tested. Stainless Steel Heat Exchanger is required if mixed air temperature is less than 45°F.

Fan & Limit Controls

Factory installed with fixed temperature setting.

Heat limit controls protect against overheating.

Safety Switches

Flame roll-out switches, flame sensors and combustion air inducer proving switches protect system operation.

All safety switches are monitored by the IMC unit controller and diagnostic errors are reported and recorded.

REQUIRED SELECTIONS

Gas Input - Order one:

169,000 Btuh Low Heat Gas Input (LGC156, LGC180 and LGC210 models only).

169,000 / 260,000 Btuh low/high fire - Standard Heat Gas Input.

234,000 / 360,000 Btuh low/high fire - Medium Gas Heat Input.

312,000 / 480,000 Btuh low/high fire - High Gas Heat Input (Not available for LGC156).

OPTIONS / ACCESSORIES

Factory Installed

Stainless Steel Heat Exchanger

Required if mixed air temperature is below 45°F.

Low Temperature Vestibule Heater

Electric heater automatically controls minimum temperature in gas burner compartment when temperature is below -40°F. C.G.A. certified to allow operation of unit down to -60°F.

Discharge Air Temperature Sensor

Sensor sends information to the IMC to cycle up to 4 stages of heating or cooling to maintain the discharge air setpoints for heating or cooling. Optional sensor is shipped with the unit for remote field installation in the supply duct.

Factory or Field Installed

Field Installed

Combustion Air Intake Extensions

Recommended for use with existing flue extension kits in areas where high snow drifts can block intake air.

Side Gas Piping Kit

Kit allows gas to be brought into the unit from the side. Includes gas shut-off valve and all piping and connections needed.

LPG/Propane Kits

Conversion kit to field change over units from Natural Gas to LPG/Propane.

Vertical Vent Extension Kit

Exhausts flue gases vertically above unit.

FEATURES AND BENEFITS

9 BLOWER

A wide selection of supply air blower options are available to meet a variety of air flow requirements.

Motor

Overload protected, equipped with ball bearings.

Belt drive motors are offered in several different sizes to maximize air performance.

Motor Efficiency

Specify standard or high.

Supply Air Blower

Forward curved blades, blower wheel is statically and dynamically balanced.

Belt drive motors with adjustable pulley for speed change.

Blower assembly slides out of unit for servicing.

Grease fittings furnished.

REQUIRED SELECTIONS

Supply Air Blower

Order Standard or High Efficiency Blower motor (See Blower Data Table for specifications).

Order one drive kit, see Drive Kit Specifications Table.

CABINET

Construction

Heavy-gauge steel panels and full perimeter heavy-gauge galvanized steel base rail provides structural integrity for transportation, handling, and installation.

10 Base rails have rigging holes. Three sides of the base rail have fork slots.

Raised edges around duct and power entry openings in the bottom of the unit provide additional protection against water entering the building.

Air-Flow Choice

Units are available in down-flow (vertical) or horizontal return air flow configuration.

Horizontal air flow requires Horizontal Roof Curb.

Horizontal Return Air Panel Kit is also required if converting a down-flow configured unit to horizontal air flow.

11 Power and Gas Entry

Electrical and gas lines can be brought through the unit base or through horizontal access knock-outs.

12 Exterior Panels

Constructed of heavy-gauge, galvanized steel with a two-layer enamel paint finish.

13 Insulation

All panels adjacent to conditioned air are fully insulated with non-hygroscopic fiberglass insulation.

Unit base is fully insulated. The insulation also serves as an air seal to the roof curb, eliminating the need to add a seal during installation.

14 Access Panels

Hinged access panels are provided for 2 compressor/controls/heating areas, blower access and air filter/economizer access.

All panels have seals and quarter-turn latching handles to provide a tight air and water seal.

REQUIRED SELECTIONS

Air Flow Configuration

Specify horizontal or down-flow.

OPTIONS / ACCESSORIES

Factory Installed

Corrosion Protection

Polymeric epoxy coating that is deposited by electrical transport (electrophoresis), using a process known as electrocoat (e-coat). Available for enhanced coil corrosion protection. Factory installed on the condenser coil, evaporator coil, or both.

Field Installed

Coil Guards

Painted, galvanized steel wire guards to protect outdoor coil. Not used with Hail Guards.

Grille Guards

Protects the space between outdoor coils and main cabinet.

Hail Guards

Constructed of heavy gauge steel, painted to match cabinet, helps protect outdoor coils from hail damage. Not used with Coil Guards.

Horizontal Return Air Panel Kit

Required for horizontal applications with Horizontal Roof Curb, contains panel with return air opening for field replacement of existing unit panel and panel to cover bottom return air opening in unit, see dimension drawings.

INDOOR AIR QUALITY

15 Air Filters

Disposable 2 inch filters furnished as standard.

OPTIONS / ACCESSORIES

Factory or Field Installed

Healthy Climate® High Efficiency Air Filters

Disposable MERV 11 (Minimum Efficiency Reporting Value based on ASHRAE 52.2) efficiency 2 inch pleated filters.

Field Installed

Healthy Climate® High Efficiency Air Filters

Disposable MERV 15 (Minimum Efficiency Reporting Value based on ASHRAE 52.2) efficiency 2 inch pleated filters.

Healthy Climate® UVC Germicidal Lamps

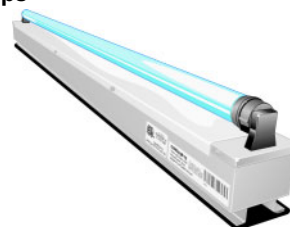

Germicidal lamps emit ultra-violet (UV-C) energy, which has been proven to be effective in reducing microbes such as viruses, bacteria, yeasts, and molds. This process either destroys the organism or controls its ability to reproduce.

UV-C energy greatly reduces the growth and proliferation of mold and other bioaerosols (bacteria and viruses) on illuminated surfaces (particularly coil and drain pan).

Lamps are field installed in the blower/evaporator coil section.

All necessary hardware for installation is included.

Lamps operate on 208/230V power supply. Step-down transformer furnished on models used with 460V and 575V rooftop units.

Magnetic safety interlock terminates power when access panels are removed.

Approved by ETL.

Replacement Filter Media Kit With Frame

Replaces existing pleated filter media. Includes washable metal mesh screen and metal frame with clip for holding replaceable non-pleated filter media. Filter media is furnished.

Indoor Air Quality (CO₂) Sensor

Monitors CO₂ levels, reports to IMC board which adjusts economizer dampers as needed.

FEATURES AND BENEFITS

ELECTRICAL

REQUIRED SELECTIONS

Voltage Choice

Specify 208/230V, 460V or 575V 3-phase-60hz when ordering base unit.

OPTIONS / ACCESSORIES

Factory Installed

Phase Monitor

Protects unit against premature equipment failure caused by phase loss, phase reversal, phase unbalance, undervoltage and overvoltage.

Factory or Field Installed

16 Circuit Breakers up to 250 Amp

HACR circuit breaker without power distribution lugs. Accessible from outside of unit, spring-loaded weatherproof cover furnished. Main power to the unit is field connected to the circuit breaker which allows all power to be shutoff for service. Circuit breaker is sized to the unit maximum overcurrent protection (MOCP) size.

Disconnect Switch up to 250 Amp

Accessible from outside of unit, spring loaded weatherproof cover furnished. Main power to the unit is field connected to the disconnect which allows all power to be shut off for service. See Optional Electrical Tables for field installed disconnect switches.

GFI Service Outlets (2)

115v ground fault circuit interrupter (GFCI) type, field wired or unit powered.

SERVICEABILITY

Designed to streamline general maintenance and decrease troubleshooting time.

Diagnostics

IMC diagnostic codes pinpoint problems, minimizing troubleshooting time.

Marked & Color-Coded Wiring

All electrical wiring is color-coded and marked to identify which components it is connecting.

Electrical Plugs

Positive connection electrical plugs are used to connect common accessories or maintenance parts for easy removal or installation.

Tool-less, Hinged Access Panels

Large access panels are hinged and have quarter-turn, latching handles for quick and easy access to maintenance areas.

Filter access panels are hinged for easy access to the filters.

Blower Access

Blower assembly slides out of the unit for easy access.

Coil Cleaning

Slab condenser coils allow easier cleaning.

Standard Components

A large number of common maintenance parts are standard throughout the entire range of sizes (3-30 tons), reducing the need to carry a lot of different parts to the job or in inventory.

Compressor Compartment

Compressors are located near the perimeter of the unit for easier access. Compressors are isolated from the condenser air flow allowing system operation checks to be done without changing the air flow across the outdoor coils.

Thermal Expansion Valves

Thermal expansion valves are located near the perimeter of the unit for easier access.

Removable element head allows change out of element and bulb without removing the TXV.

Service Valves (optional)

Optional factory installed liquid and discharge service valves allow refrigerant to be isolated to the high side for service work on the low side of the refrigeration system.

CONTROLS

17 INTELLIGENT UNIT CONTROLLER

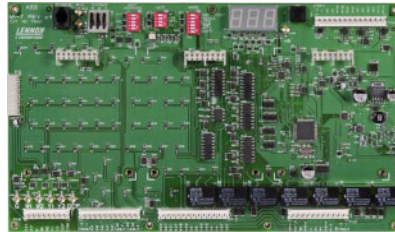

The Integrated Modular Controller (IMC) is a solid-state microprocessor-based control board that provides flexible control of all unit functions.

All control voltage is provided via a 24V (secondary) transformer with built-in circuit breaker protection.

Built-in functions include:

Blower On/Off Delay - Adjustable time delay between blower on and off.

Blower Air Delivery Options - Two air delivery options; single zone or bypass zoning with bypass dampers.

Built-in Control Parameter Defaults - No programming required.

Compressor Time-Off Delay - Adjustable time delay between compressor shutoff and start up.

DDC Compatible - Various third party DDC controllers can be factory or field installed. Refer to the Unit Controllers section for details.

Dirty Filter Switch Input - When a Dirty Filter Switch is installed, the IMC will signal when the indoor blower static pressure increases, indicating a dirty filter condition. Switch is optional and can be factory or field installed.

Discharge Air Temperature Control -

The IMC will cycle up to 4 stages of heating or cooling to maintain the discharge air setpoints for heating or cooling. Optional sensor for remote field installation in the supply duct.

Display/Sensor Readout - Displays control parameters, diagnostic codes, and sensor readings. The IMC unit controller displays temperature readings from return air, supply air, and outdoor air sensors that are furnished as standard on all L Series units. IMC will also display readings from optional sensors such as zone sensors, CO₂ sensors or relative humidity sensors.

Economizer Control Choice - The economizer is controlled by an add-on board to the IMC. The economizer control board has several choices for controlling the economizer. See Economizer / Outdoor Air / Exhaust Options.

Fresh Air Tempering - Provides heating and cooling as needed to maintain the supply air temperature within a comfort range, regardless of the thermostat demand. Sensor ships with unit but must be field installed in the supply air duct. Requires change to IMC (ECTO) parameter in the field to activate this mode of operation.

Extensive Unit Diagnostics - The IMC monitors all sensors and functions related to unit operation to provide critical information. The IMC will display detailed diagnostic information with over 90 diagnostic codes to pinpoint any problems and reduce troubleshooting time. All diagnostic codes are listed inside control access panel for easy reference.

Exhaust Fan Control Modes - Fans controlled by fresh air damper position or building static differential pressure transducer.

Permanent Diagnostic Code Storage - Maintains diagnostic codes through a power failure.

Field Changeable Control Parameters - Over 200 different control parameters allow customization of the unit operation by changing delays, cooling stages, deadbands, and setpoints.

Indoor Air Quality Input - The IMC is Demand Control Ventilation ready from the factory (optional field installed CO₂ sensor required). Two modes of operation are available: setpoint and proportional.

1 - Setpoint - Opens the economizer dampers to full position when CO₂ setpoint level is reached.

2 - Proportional - Opens the dampers at the first set point and gradually increases it as the CO₂ level increases until the second setpoint is reached.

Low Ambient Controls - Allows unit cooling operation down to 0°F.

FEATURES AND BENEFITS

CONTROLS - CONT.

Gas Valve Time Delay Between First and Second Stage - Allows gradual increase of input rate.

Minimum Compressor Run Time - Ensures proper oil return to the compressor.

Network Capable - The IMC can be daisy chained to other L Series units or L Connection® Network controllers using twisted pair wire.

Night Setback Mode - Adjusts setpoints, closes outdoor air dampers and operates the blower on demand, may be customized for special requirements.

Return Air Temperature Limit Control - Allows the user to override the demands based upon the return air temperature during either heating or cooling operation. Helps protect against abnormal operating conditions in the event of a room sensor or thermostat failure.

Safety Switch Input - Normally-closed digital input allows the IMC to respond to a external safety switch trip (phase protector, low voltage, etc.) shutting down unit operation.

Service Relay Output - Digital output can indicate a critical error has occurred to an external control device. Can also be configured to energize based on relative humidity, indoor air quality, outdoor air temperature or unit operation.

Smoke Alarm Mode - Control board has four choices for responding to a smoke alarm.

1 - Unit Off - unit will turn off.

2 - Positive Pressure - blower is energized, exhaust fan is de-energized, and the outdoor air dampers are opened.

3 - Negative Pressure - blower is energized, exhaust fan is energized, and the outdoor air dampers are closed.

4 - Purge - blower is energized, exhaust fan is energized, and the outdoor air dampers are opened.

Staging - 2 heat/2 cool. Capable of up to 4 heat/4 cool with zone sensor or third party DDC control system.

“Strike Three” Protection - Ends cooling or heating operation when any of the following occurs three times (adjustable) within a thermostat cycle: low pressure trip, high pressure trip, heat limit trip, or freeze-stat trip.

Gas Reheat - Control parameter option that allows simultaneous heating and cooling operation for controlling humidity for process air applications such as supermarkets. Field installed relative humidity sensor or dehumidistat can be used.

On-Demand Dehumidification - Monitors and controls condenser reheat operation with Humiditrol option. Prioritizes heat and cool demand with dehumidification demand. Reheat demand can be enabled by digital input or a field installed relative humidity sensor can be used.

Thermostat Bounce Delay - Protects compressor from short cycling when mechanical thermostat is used.

Warm-up Mode Delay - Adjustable time that the economizer dampers are kept in the closed position during morning warm-up.

On-Board User Interface - Push-button, DIP switches used with three-digit display readout for field adjustment of control parameters. LED indicators for L Connection Network (transmit and receive) and for each thermostat input.

PC Interface - PC with optional Unit Controller software may be used to field or remotely adjust parameters, read alarms, or display unit status.

Zone Sensor Operation - Controls zone temperature with up to 4 stages of heating or cooling with optional zone sensor.

OPTIONS / ACCESSORIES

Factory or Field Installed

Blower Proving Switch

Monitors blower operation, shuts down unit if blower fails. Factory installed.

Dirty Filter Switch

Senses static pressure increase indicating dirty filter condition.

Fresh Air Tempering

Provides heating and cooling as needed to maintain the supply air temperature within a comfort range, regardless of the thermostat demand. Sensor ships with unit but must be field installed in the supply air duct. Requires change to IMC (Integrated Modular Control) (ECTO) parameter in the field to activate this mode of operation.

Smoke Detector

Photoelectric type, installed in supply air section or return air section or both sections

Interoperability via BACnet® or LonTalk® Protocols

Communication compatible with third-party automation systems that support the BACnet Application Specific Controller device profile, LonMark® Space Comfort Controller functional profile, or LonMark Discharge Air Controller functional profile. See Page 48.

Commercial Control Systems

L Connection® Network

Complete building automation control system for single or multi-zone applications. Options include local interface, software for local or remote communication, and hardware for networking other control functions. See L Connection Network Engineering Handbook Bulletin for details.

Sectra™ Commercial Zoning System

Control system to complement the IMC in bypass zoning applications and single zone control. Options include local interface, software for local or remote communication, and hardware for networking other control functions.

See Page 44.

Aftermarket DDC

Novar® Unit Controller and options.

See Page 47.

Thermostats

Control system and thermostat options. Aftermarket unit controller options. See See Page 52.

Field Installed

Humidity Sensor Kit, Remote Mounted

Humidity sensor required with factory installed Humiditrol™ Option or Supermarket reheat field selectable option.

OPTIONS / ACCESSORIES

ECONOMIZER/OUTDOOR AIR/EXHAUST

Factory or Field Installed

18 Economizer

Parallel gear driven action return air and outdoor air dampers, plug-in connections to unit, nylon bearings, neoprene seals, 24 volt fully modulating spring return motor, adjustable minimum damper position, damper assembly slides in unit, outdoor air hood must be ordered separately, optional down-flow barometric relief dampers available, choice of economizer controls. The IMC add-on board for economizer control is included with the economizer. Control board has four choices for controlling the economizer (DIP switch selections).

1 - Differential Sensible Control -

Factory setting. Uses outdoor air and return air sensors that are furnished with the unit. The IMC compares outdoor air and return air and using setpoints, enables the economizer when the outdoor air temperature is below the configured setpoint and cooler than return air.

NOTE - Differential Sensible Control can be configured in the field to provide Offset Differential Sensible Control or Single Sensible Control.

In Offset Differential Sensible Control mode, the economizer is enabled if the temperature differential (offset) between outdoor air and return air reaches the configured setpoint.

In Single Sensible Control mode, the economizer is enabled when outdoor air temperature falls below the configured setpoint.

2 - Global Control - The IMC communicates with a DDC system with one global sensor (enthalpy or sensible) to determine whether outside air is suitable for free cooling on all units connected to the control system. Sensor must be field provided.

3 - Single Enthalpy Control - Outdoor air enthalpy sensor enables economizer if the outdoor enthalpy is less than the setpoint of the board. Factory installed.

4 - Differential Enthalpy Control - Two solid-state enthalpy sensors allow the economizer control board to select between outdoor air or return air, whichever has lower enthalpy. Factory installed.

Outdoor Air Dampers, Manual or Motorized

Linked mechanical dampers, 0 to 25% (fixed) outdoor air adjustable, installs in unit, outdoor air hood must be ordered separately. Motorized model features fully modulating spring return damper motor with plug-in connection. Manual model features a slide damper.

Minimum mixed air temperature in heating mode 45°F with aluminized steel heat exchanger. Maximum mixed air temperature in cooling mode: 100°F.

Outdoor Air Hood

Required with LAREMD Economizer, LAOAD and LAOADM Outdoor Air Damper Sections, cleanable aluminum mesh fresh air filters furnished.

Down-Flow Barometric Relief Dampers

Allows relief of excess air, aluminum blade dampers prevent blow back and outdoor air infiltration during off cycle, bird screen furnished. Dampers are required with Standard Static Power Exhaust Fans. Down-Flow Barometric Relief Damper Hood is available and must be ordered extra.

Factory or Field Installed

Standard Static Power Exhaust Fans

Two, 1/3 hp motors with 20 in., five blade propeller-type fans with a total power input of 750 Watts and a total air volume of 8630 cfm at 0 in. w.g.

Motor is inherently protected and enclosed for maximum protection from weather, dust and corrosion. Installs internal to unit for down-flow applications only with economizer option, provides exhaust air pressure relief, interlocked to run when return air dampers are closed and supply air blower is operating, fan runs when outdoor air dampers are 50% open (adjustable), motor is overload protected, steel cabinet and hood painted to match unit, requires optional Down-flow Economizer Barometric Relief Dampers.

See Power Exhaust Blower Tables.

Power Exhaust Control Options:

Damper Position Control

IMC controls exhaust fan based on economizer damper position.

Field Installed

Down-Flow Barometric Relief Damper Hood

Use with Barometric Relief Dampers.

Horizontal Barometric Relief Dampers

Aluminum blade dampers prevent blow back and outdoor air infiltration during off cycle, field installed in return air duct, bird screen furnished.

CEILING DIFFUSERS

Field Installed

Ceiling Diffusers (Flush or Step-Down)

Aluminum grilles, large center grille, insulated diffuser box with flanges, hanging rings furnished, interior transition (even air flow), internally sealed (prevents recirculation), adapts to T-bar ceiling grids or plaster ceilings.

Transitions (Supply and Return)

Used with diffusers, installs in roof curb, galvanized steel construction, flanges furnished for duct connection to diffusers, fully insulated.

ROOF CURBS

Field Installed

Nailer strip furnished, mates to unit, shipped knocked down.

Standard roof curb corners fasten together with furnished hardware.

Cliplock curbs use interlocking tabs to fasten together. No tools required.

Standard Down-Flow

US National Roofing Contractors Approved, available in 14 and 24 inch heights.

Horizontal

Converts unit from down-flow to horizontal (side) air flow, return air is on unit, supply air is on curb, see dimension drawings. Curbs for rooftop applications meet National Roofing Code requirements. Requires Horizontal Return Air Panel. Available in 26, 30, 37 and 41 inch heights. Optional Insulation Kit is available to help prevent sweating.

Cliplock 1000 Full Perimeter

Down-Flow

Available in 8, 14, 18, and 24 inch heights.

OPTIONS / ACCESSORIES

HUMIDITROL® CONDENSER REHEAT OPTION

156H & 180H (3 Compressors) 210H, 240H & 300S (4 Compressors)

Factory installed option designed to control humidity.

Provides dehumidification on demand using ASHRAE 90.1 recommended method for reheat with comfort conditioning humidity control.

In addition to a thermostat/room sensor used for conventional operation, a humidity sensor is required and must be located in the occupied space.

Humidity sensor provides input to the Integrated Modular Control (IMC) which is used to control activation of the dehumidification operation.

Reheat controls are located in the compressor control section of the unit for easy access.

Benefits

Improves indoor air quality.

Helps prevent damage due to high humidity levels.

Improves comfort levels by reducing space humidity levels.

OPERATION

No Dehumidification Demand

The unit will operate conventionally whenever there is a demand for cooling or heating and no dehumidification demand.

Free cooling is only permitted when there is no demand for dehumidification.

Dehumidification Demand Only

The IMC is factory set at 60% relative humidity setpoint and can be adjusted at the IMC or with optional Unit Controller Software.

For Network Control Panel (NCP) applications, the humidity setpoint can be adjusted at the NCP. The unit will operate in the dehumidification mode until the relative humidity of the conditioned space is 3% below the setpoint.

Reheat operation will initiate on a

dehumidification demand and does not require a cooling demand.

The reheat coil is sized to offset most of the first stage sensible cooling effect during reheat only operation. This reduction in sensible cooling capacity extends compressor run time to control humidity when cooling loads are light.

Solenoid valves divert hot gas from compressor 1 and compressor 2 to the reheat coil.

The cooled and dehumidified air from the evaporator is then reheated as it passes through the reheat coil.

The de-superheated and partially condensed refrigerant continues to the outdoor condenser coil where condensing is completed.

The unit will continue to operate in this mode until the dehumidification demand is satisfied.

A heating demand will terminate reheat operation.

Dehumidification and Cooling Demand for 156H/180H three compressor models (Thermostat Application)

If both a dehumidification and a first stage cooling demand occur, the system will operate compressor 1 and compressor 2 in reheat and compressor 3 will operate in cooling.

A demand for second stage cooling will terminate reheat operation until second stage cooling demand is satisfied.

Dehumidification and Cooling Demand for 210H/240H/300S four compressor models (Thermostat Application)

If both a dehumidification and a first stage cooling demand occur, the system will operate compressor 1 and compressor 2 in reheat and compressor 3 and compressor 4 will operate in cooling.

A demand for second stage cooling will terminate reheat operation until second stage cooling demand is satisfied.

Dehumidification and Cooling Demand for 156H/180H three compressor models (Room Sensor Application)

If both a dehumidification and a first stage cooling demand occur, the system will operate compressor 1 and compressor 2 in reheat and compressor 3 will operate in cooling.

A demand for second stage cooling will terminate reheat and compressor 3 operation and operate compressor 1 and compressor 2 in cooling until second stage cooling demand is satisfied.

A demand for third stage cooling will operate compressor 1, compressor 2 and compressor 3 in cooling.

Dehumidification and Cooling Demand for 210H/240H/300S four compressor models (Room Sensor Application)

If both a dehumidification demand and a first stage cooling demand occur, the system will operate compressor 1 and compressor 2 in reheat and compressor 3 will operate in cooling.

If a demand for second stage cooling is initiated, compressor 1 and compressor 2 will operate in reheat and compressor 3 and compressor 4 will operate in cooling.

A demand for third stage cooling will terminate reheat and compressor 4 operation and operate compressor 1, compressor 2 and compressor 3 in cooling until third stage cooling demand is satisfied. A demand for fourth stage cooling will operate compressor 1, compressor 2, compressor 3 and compressor 4 in cooling.

OPTIONS/ACCESSORIES

Field Installed

Humidity Sensor Kit, Remote Mounted

Humidity sensor required with factory installed Humiditrol™ Option or Supermarket reheat field selectable option.

OPTIONS

HUMIDITROL® CONDENSER REHEAT OPTION (CONTINUED)

REFRIGERANT SCHEMATIC (156H, 180H MODELS ONLY)

NOTE: Refrigerant circuits one and two operates when there is a first-stage thermostat demand.

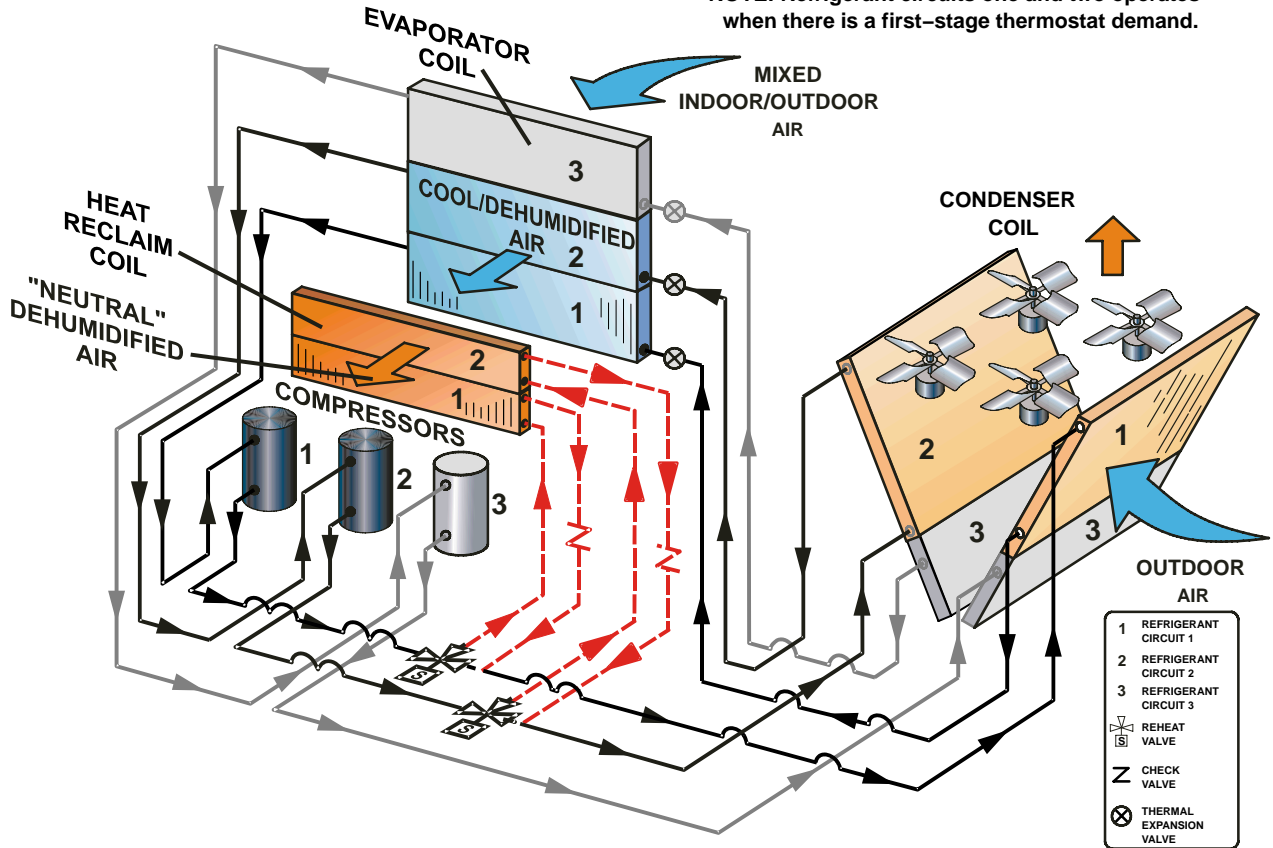

REFRIGERANT SCHEMATIC (210H, 240H and 300S MODELS ONLY)

NOTE: Refrigerant circuits one and two operates when there is a first-stage thermostat demand.

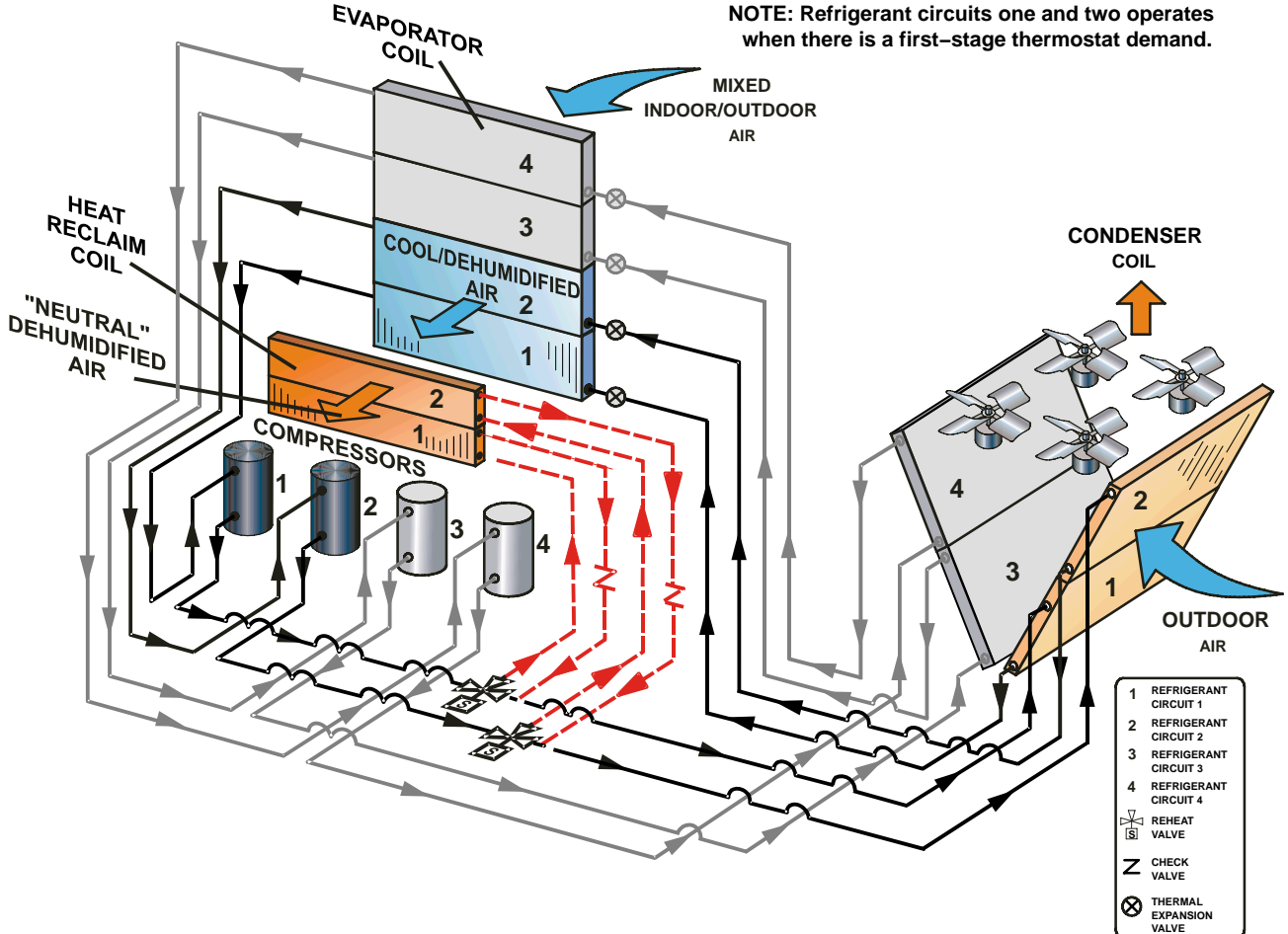

OPTIONS / ACCESSORIES

Item	Catalog No.	156	180	210	240	300S
COOLING SYSTEM						
Condensate Drain Trap	PVC - LTACDKP09/36	76M18	⊗	⊗	⊗	⊗
	Copper - LTACDKC09/36	76M19	⊗	⊗	⊗	⊗
Corrosion Protection	Factory	○	○	○	○	○
Efficiency	Standard	Factory		○	○	○
	High	Factory	○	○	○	○
Refrigerant Type	R-22	Factory	○	○	○	○
	R-410A	Factory	○	○	○	○
Service Valves (not for Humiditrol Units)	Factory	○	○	○	○	○
Stainless Steel Condensate Drain Pan	Factory	○	○	○	○	○
HEATING SYSTEM						
Combustion Air Intake Extensions	LTACA1K10/15	89L97	1x	1x	1x	1x
Gas Heat Input	Low - 169 kBtuh input	Factory	○	○	○	
	Standard - 260 kBtuh input	Factory	○	○	○	○
	Medium - 360 kBtuh input	Factory	○	○	○	○
	High - 480 kBtuh input	Factory		○	○	○
Low Temperature Vestibule Heater	Factory	○	○	○	○	○
LPG/Propane Conversion Kits	169 kBtuh input (order 1 kit) - LTALPGK-130	72M94	1x	1x	1x	
	260 kBtuh input (order 2 kits) - LTALPGK-130	72M94	1x	1x	1x	1x
	360 kBtuh input (order 2 kits) - LTALPGK-180	72M95	1x	1x	1x	1x
	480 kBtuh input (order 2 kits) - LTALPGK-240	72M96		1x	1x	1x
Side Gas Piping Kit	C1GPKT01C-	85M31	x	x	x	x
Stainless Steel Heat Exchanger	Factory	○	○	○	○	○
Vertical Vent Extension	LTAWEK10/15	73M72	1x	1x	1x	1x
BLOWER - SUPPLY AIR						
Constant Air Volume	2 hp Standard or High Efficiency	Factory	○			
	3 hp Standard or High Efficiency	Factory	○	○	○	
	5 hp Standard or High Efficiency	Factory	○	○	○	○
	7.5 hp Standard or High Efficiency	Factory		○	○	○
	10 hp Standard or High Efficiency	Factory				○
CABINET						
Coil Guards		88K52	x	x	x	x
Grille Guards		72K78	x	x	x	x
Hail Guards		88K25	x	x	x	x
Horizontal Return Air Panel Kit		87M00	x	x	x	x
CONTROLS						
Blower Proving Switch	C0SWCH01AE1-	30K49	⊗	⊗	⊗	⊗
Commercial Controls	L Connection® Building Automation System	- - -	⊗	⊗	⊗	⊗
	Novar® ETM-2051 Unit Controller	71M58	⊗	⊗	⊗	⊗
	Sectra™ Zoning System with Bypass Control - C0CTRL04BD1L	34M42	⊗	⊗	⊗	⊗
	Sectra™ Zoning System Single Zone Control - C0CTRL03BD1L	71M59	⊗	⊗	⊗	⊗
Dirty Filter Switch	C0SWCH00AE1-	30K48	⊗	⊗	⊗	⊗
Fresh Air Tempering	C0SNDC03AE1-	45L78	⊗	⊗	⊗	⊗
Smoke Detector - Supply	LTSASDK10/36	70K87	⊗	⊗	⊗	⊗
Smoke Detector - Return	LTARSDK10/30	70K86	⊗	⊗	⊗	⊗

NOTE - The catalog and model numbers that appear here are for ordering field installed accessories only.

⊗ - Field Installed or Configure to Order (factory installed)

○ - Configure to Order (Factory Installed)

X - Field Installed.

¹ Order two each.

OPTIONS / ACCESSORIES

Item	Catalog No.	156	180	210	240	300S
INDOOR AIR QUALITY						
Air Filters						
Healthy Climate® High Efficiency Air Filters 24 x 24 x 2 - order 6 per unit	MERV 11 - C1FLTR20C-1-	97L87	⊗	⊗	⊗	⊗
	MERV 15 - C1FLTR50C-1-	28W05	x	x	x	x
Replaceable Media Filter With Metal Mesh Frame (includes non-pleated filter media)	C1FLTR30C 24 x 24 x 2 order 6 per unit	44N61	x	x	x	x
Germicidal Lamps						
Healthy Climate® UVC Germicidal Lamps	208/230V - C1UVCL10C	X7521	x	x	x	x
	460V - C1UVCL10C	X7526	x	x	x	x
	575V - C1UVCL10C	X7531	x	x	x	x
Indoor Air Quality Sensors						
CO ₂ Sensor - white case w/ display	C0SNSR50AE1L	77N39	x	x	x	x
CO ₂ Sensor - white case, no display	C0SNSR52AE1L	87N53	x	x	x	x
CO ₂ Sensor - black case w/ display	C0SNSR51AE1L	87N52	x	x	x	x
CO ₂ Sensor - black case, no display	C0SNSR53AE1L	87N54	x	x	x	x
CO ₂ Sensor Duct Mounting Kit	C0MISC19AE1-	85L43	x	x	x	x
Aspiration Box for duct mounting Sensor	C0MISC16AE1-	90N43	x	x	x	x
Handheld CO ₂ Monitor	LTAIAQSHM03/36	70N93	x	x	x	x
ELECTRICAL						
Voltage 60 hz	208/230V - 3 phase	Factory	○	○	○	○
	460V - 3 phase	Factory	○	○	○	○
	575V - 3 phase	Factory	○	○	○	○
HACR Circuit Breakers		Factory	○	○	○	○
Disconnect Switch - See Electrical / Electric Heat Tables for selection	80 Amp	84M13	⊗	⊗	⊗	⊗
	150 Amp	84M14	⊗	⊗	⊗	⊗
	250 Amp	84M15	⊗	⊗	⊗	⊗
GFI Service Outlets	LTAGFIK10/15	74M70	⊗	⊗	⊗	⊗
Phase Monitor		Factory	○	○	○	○
ECONOMIZER						
Economizer - Order Hood Separately	LAREMD18/24	16K95	⊗	⊗	⊗	⊗
Outdoor Air Hood (down-flow) Number of Filters - 16 x 25 x 1 in.	C1HOOD10C-1 (3)	85M25	⊗	⊗	⊗	⊗
Economizer Controls						
Differential Enthalpy	C1SNSR07AE1	86M33	⊗	⊗	⊗	⊗
Single Enthalpy	C1SNSR06AE1	86M32	⊗	⊗	⊗	⊗
Global, Enthalpy	Sensor Field Provided	Factory	○	○	○	○
Differential Sensible	Furnished	Factory	○	○	○	○
Barometric Relief						
Down-Flow Barometric Relief Dampers - Order Hood Separately	LAGED18/24	16K98	⊗	⊗	⊗	⊗
Hood for Down-Flow LAGED	C1HOOD20C-1	85M26	⊗	⊗	⊗	⊗
Horizontal Barometric Relief Dampers - Hood Furnished	LAGEDH18/24	16K99	⊗	⊗	⊗	⊗

NOTE - The catalog and model numbers that appear here are for ordering field installed accessories only.

⊗ - Field Installed or Configure to Order (factory installed)

○ - Configure to Order (Factory Installed)

X - Field Installed.

OPTIONS / ACCESSORIES

Item	Catalog No.	156	180	210	240	300S
HUMIDITROL® CONDENSER REHEAT OPTION						
Humiditrol	Factory	H	H	H	H	S
Humidity Sensor Kit, Remote Mounted (required)	C0SNSR31AE-1	17M50	x	x	x	x
Remote Sensor Wall Seal Plate	C0MISC18AE-1	58L33	x	x	x	x
OUTDOOR AIR						
Outdoor Air Dampers						
Damper Section (down-flow) - Order Hood Separately	Motorized - LAOADM18/24	16K94	⊗	⊗	⊗	⊗
	Manual - LAOAD18/24	16K93	⊗	⊗	⊗	⊗
Outdoor Air Hood (down-flow) - Number of Filters - 16 x 25 x 1 in.	C1HOOD10C (3)	85M25	⊗	⊗	⊗	⊗
Power Exhaust						
Standard Static	208/230V - C1PWRE20C-1Y	85M37	⊗	⊗	⊗	⊗
	460V - C1PWRE20C-1G	85M38	⊗	⊗	⊗	⊗
	575V - C1PWRE20C-1J	85M39	⊗	⊗	⊗	⊗
ROOF CURBS - CLIPLOCK 1000						
Down-Flow						
8 in. height	C1CURB40CD1	26W32	x	x	x	x
14 in. height	LARMF18/30S-14	33K44	x	x	x	x
18 in. height	LARMF18/30S-18	33K45	x	x	x	x
24 in. height	LARMF18/30S-24	33K46	x	x	x	x
Horizontal - Canada Only						
26 in. height	LARMFH18/24S-26	33K47	x	x	x	
37 in. height	LARMFH18/24S-37	45K70	x	x	x	
ROOF CURBS - STANDARD						
Down-Flow						
14 in. height	LARMF18/36-14	16K87	x	x	x	x
24 in. height	LARMF18/36-24	16K88	x	x	x	x
Horizontal						
26 in. height - Rooftop Applications	LARMFH18/24-26	97J33	x	x	x	
37 in. height - Slab Applications	LARMFH18/24-37	38K53	x	x	x	
30 in. height - Rooftop applications	LARMFH30/36-30	33K79				x
41 in. height - Slab applications	LARMFH30/36-41	38K54				x
Horizontal Air Panel Kit	C1HAP10C-1	87M00	x	x	x	x
Insulation Kits						
for LARMFH18/24-26	C1INSU11C-1	73K32	x	x	x	
for LARMFH18/24-37	C1INSU13C-1	73K34	x	x	x	
for LARMFH30/36-30		73K33				x
for LARMFH30/36-41		73K35				x
CEILING DIFFUSERS						
Step-Down - Order one	RTD11-185	29G06	x	x		
	(Canada Only) RTD11-150/180S	13K63	x	x		
	RTD11-275-R	29G07			x	x
	(Canada Only) RTD11-275S	13K64			x	x
Flush - Order one	FD11-185	29G10	x	x		
	(Canada Only) FD11-150/180S	13K58	x	x		
	FD11-275-R	29G11			x	x
	(Canada Only) FD11-275S	13K59			x	x
Transitions (Supply and Return) - Order one	LASRT18	19K01	x	x		
	(Canada Only) LASRT18S	33K48	x	x		
	LASRT21/24	19K02			x	x
	(Canada Only) LASRT21/24S	33K49			x	x

NOTE - The catalog and model numbers that appear here are for ordering field installed accessories only.

⊗ - Field Installed or Configure to Order (factory installed)

X - Field Installed.

S - Configure to Order (Factory Installed) Standard Efficiency Models Only

H - Configure to Order (Factory Installed) High Efficiency Models Only

SPECIFICATIONS

13 TON

General Data		Nominal Tonnage	13 Ton	
		Model No.	LGC156H2B	LGC156H4B
		Efficiency Type	High	High
Cooling Performance	Gross Cooling Capacity - Btuh (kW)		160,000 (46.8)	159,000 (46.6)
	¹ Net Cooling Capacity - Btuh (kW)		156,000 (45.7)	154,000 (45.1)
	ARI Rated Air Flow - cfm (L/s)		5100 (2405)	5200 (2455)
	Total Unit Power (kW)		12.8	12.8
	¹ EER (Btuh/Watt)		12.2	12.0
	² Integrated Part Load Value (Btuh/Watt)		13.6	13.3
	Refrigerant Type		R-22	R-410
	Refrigerant Charge Furnished	Circuit 1	11 lbs. 0 oz. (4.99 kg)	13 lbs. 0 oz. (5.9 kg)
	Circuit 2	11 lbs. 0 oz. (4.99 kg)	13 lbs. 0 oz. (5.9 kg)	
	Circuit 3	11 lbs. 0 oz. (4.99 kg)	13 lbs. 0 oz. (5.9 kg)	
Refrigerant Charge Furnished with Humiditrol® Option	Circuit 1	13 lbs. 8 oz. (6.12 kg)	13 lbs. 0 oz. (5.9 kg)	
	Circuit 2	13 lbs. 8 oz. (6.12 kg)	13 lbs. 0 oz. (5.9 kg)	
	Circuit 3	11 lbs. 0 oz. (4.99 kg)	13 lbs. 0 oz. (5.9 kg)	
Gas Heating Options Available - See page 18		Low (1 Stage), Standard (2 Stage), Medium (2 Stage)		
Compressor Type (no.)		Scroll (3)		Scroll (3)
Outdoor Coils	Net face area - sq. ft. (m ²) total	56.5 (5.25)		56.5 (5.25)
	Tube diameter - in. (mm) - No. of rows	3/8 (9.5) - 2		3/8 (9.5) - 2
	Fins per inch (m)	20 (787)		20 (787)
Outdoor Coil Fans	Motor horsepower (W)	(4) 1/3 (249)		(4) 1/3 (249)
	Motor rpm	1075		1075
	Total Motor watts	1395		1395
	Diameter - in. (mm) - No. of blades	(4) 24 (610) - 3		(4) 24 (610) - 3
	Total Air volume - cfm (L/s)	15,450 (7290)		15,450 (7290)
Indoor Coils	Net face area - sq. ft. (m ²) total	22.3 (2.07)		22.3 (2.07)
	Tube diameter - in. (mm) - No. of rows	3/8 (9.5) - 3		3/8 (9.5) - 3
	Fins per inch (m)	14 (551)		14 (551)
	Drain connection - number and size	(1) 1 in. NPT coupling		
	Expansion device type	Balanced Port Thermostatic Expansion Valve, removeable power head		
³ Indoor Blower and Drive Selection	Nominal motor output	2 hp (1.5 kW)	3 hp (2.2 kW)	5 hp (3.7 kW)
	Maximum usable motor output (US Only)	2.3 hp (1.7 kW)	3.45 hp (2.6 kW)	5.75 hp (4.3 kW)
	Motor - Drive kit	2 hp kit #A - 535 - 725 rpm	3 hp kit #A - 535 - 725 rpm kit #1 - 685 - 865 rpm ⁴ kit #2 - 685 - 865 rpm	5 hp kit #2 - 685 - 865 rpm kit #3 - 850 -1045 rpm kit #4 - 945 - 1185 rpm
	Blower wheel nominal diameter x width	(2) 15 x 15 in. (381 x 381 mm)		
Filters	Type of filter	Disposable		
	No. and size - in. (mm)	(6) 24 x 24 x 2 (610 x 610 x 51)		
Electrical characteristics		208/230V, 460V or 575V - 60 hertz - 3 phase		

NOTE - Net capacity includes evaporator blower motor heat deduction. Gross capacity does not include evaporator blower motor heat deduction.
¹ Certified in accordance with the ULE certification program, which is based on ARI Standard 340/360; 95°F (35°C) outdoor air temperature and 80°F (27°C) db/67°F (19°C) wb entering evaporator air; minimum external duct static pressure.
² Integrated Part Load Value tested at 80°F (27°C) outdoor air temperature.
³ Using total air volume and system static pressure requirements determine from blower performance tables rpm and motor output required. Maximum usable output of motors furnished are shown. In Canada, nominal motor output is also maximum usable motor output. If motors of comparable output are used, be sure to keep within the service factor limitations outlined on the motor nameplate.
⁴ Drive Kit #2 is only used with 3 hp high efficiency motor only.

SPECIFICATIONS

15 TON

General Data		Nominal Tonnage	15 Ton			
		Model No.	LGC180S2B	LGC180H2B	LGC180H4B	
		Efficiency Type	Standard	High	High	
Cooling Performance	Gross Cooling Capacity - Btuh (kW)		186,000 (54.5)	188,000 (55.1)	186,000 (54.5)	
	¹ Net Cooling Capacity - Btuh (kW)		180,000 (52.7)	182,000 (53.3)	182,000 (53.3)	
	ARI Rated Air Flow - cfm (L/s)		6000 (2830)	5700 (2690)	5700 (2690)	
	Total Unit Power (kW)		18.0	15.4	15.4	
	¹ EER (Btuh/Watt)		10.0	11.8	11.8	
	² Integrated Part Load Value (Btuh/Watt)		10.6	13.3	13.3	
	Refrigerant Type		R-22	R-22	R-410A	
	Refrigerant Charge Furnished	Circuit 1		9 lbs. 0 oz. (4.08 kg)	11 lbs. 8 oz. (5.22 kg)	11 lbs. 8 oz. (5.22 kg)
		Circuit 2		9 lbs. 0 oz. (4.08 kg)	11 lbs. 8 oz. (5.22 kg)	11 lbs. 8 oz. (5.22 kg)
		Circuit 3		9 lbs. 0 oz. (4.08 kg)	11 lbs. 8 oz. (5.22 kg)	11 lbs. 8 oz. (5.22 kg)
Refrigerant Charge Furnished with Humiditrol® Option	Circuit 1		Not Available	14 lbs. 0 oz. (6.35 kg)	11 lbs. 8 oz. (5.22 kg)	
	Circuit 2		Not Available	14 lbs. 0 oz. (6.35 kg)	11 lbs. 8 oz. (5.22 kg)	
	Circuit 3		Not Available	11 lbs. 8 oz. (5.22 kg)	11 lbs. 8 oz. (5.22 kg)	
Gas Heating Options Available - See page 18			Low (1 Stage), Standard (2 Stage), Medium (2 Stage), or High (2 Stage)			
Compressor Type (no.)			Scroll (3)	Scroll (3)	Scroll (3)	
Outdoor Coils	Net face area - sq. ft. (m ²) total		56.5 (5.25)	56.5 (5.25)	56.5 (5.25)	
	Tube diameter - in. (mm) - No. of rows		3/8 (9.5) - 1	3/8 (9.5) - 2	3/8 (9.5) - 2	
	Fins per inch (m)		20 (787)	20 (787)	20 (787)	
Outdoor Coil Fans	Motor horsepower (W)		(4) 1/3 (249)	(4) 1/3 (249)	(4) 1/3 (249)	
	Motor rpm		1075	1075	1075	
	Total Motor watts		1370	1395	1395	
	Diameter - in. (mm) - No. of blades		(4) 24 (610) - 3	(4) 24 (610) - 3	(4) 24 (610) - 3	
	Total Air volume - cfm (L/s)		15,850 (7480)	15,450 (7290)	15,450 (7290)	
Indoor Coils	Net face area - sq. ft. (m ²) total		22.3 (2.07)	22.3 (2.07)	22.3 (2.07)	
	Tube diameter - in. (mm) - No. of rows		3/8 (9.5) - 3	3/8 (9.5) - 3	3/8 (9.5) - 3	
	Fins per inch (m)		14 (551)	14 (551)	14 (551)	
	Drain connection - number and size		(1) 1 in. NPT coupling			
Expansion device type			Balanced Port Thermostatic Expansion Valve, removeable power head			
³ Indoor Blower and Drive Selection	Nominal motor output		3 hp (2.2 kW)	5 hp (3.7 kW)	7.5 hp (5.6 kW)	
	Maximum usable motor output (US Only)		3.45 hp (2.6 kW)	5.75 hp (4.3 kW)	8.63 hp (6.4 kW)	
	Motor - Drive kit		3 hp kit #A - 535 - 725 rpm kit #1 - 685 - 865 rpm ⁴ kit #2 - 685 - 865 rpm	5 hp kit #2 - 685 - 865 rpm kit #3 - 850 - 1045 rpm kit #4 - 945 - 1185 rpm	7.5 hp kit# 5 - 945 - 1185 rpm kit# 6 - 1045 - 1285 rpm kit# 7 - 850 - 1045 rpm	
Blower wheel nominal diameter x width			(2) 15 x 15 in. (381 x 381 mm)			
Filters	Type of filter		Disposable			
	No. and size - in. (mm)		(6) 24 x 24 x 2 (610 x 610 x 51)			
Electrical characteristics			208/230V, 460V or 575V - 60 hertz - 3 phase			

NOTE - Net capacity includes evaporator blower motor heat deduction. Gross capacity does not include evaporator blower motor heat deduction.

¹ Certified in accordance with the ULE certification program, which is based on ARI Standard 340/360; 95°F (35°C) outdoor air temperature and 80°F (27°C) db/67°F (19°C) wb entering evaporator air; minimum external duct static pressure.

² Integrated Part Load Value tested at 80°F (27°C) outdoor air temperature.

³ Using total air volume and system static pressure requirements determine from blower performance tables rpm and motor output required. Maximum usable output of motors furnished are shown. In Canada, nominal motor output is also maximum usable motor output. If motors of comparable output are used, be sure to keep within the service factor limitations outlined on the motor nameplate.

⁴ Drive Kit #2 is only used with 3 hp high efficiency motor only.

SPECIFICATIONS

17.5 TON

General Data		Nominal Tonnage	17.5 Ton LGC210S2B Standard	17.5 Ton LGC210H2B High	17.5 Ton LGC210H4B High
		Model No.			
		Efficiency Type			
Cooling Performance	Gross Cooling Capacity - Btuh (kW)		212,000 (62.1)	218,000 (63.9)	212,000 (62.1)
	¹ Net Cooling Capacity - Btuh (kW)		204,000 (59.8)	210,000 (61.5)	204,000 (59.7)
	ARI Rated Air Flow - cfm (L/s)		6800 (3210)	6600 (3115)	6600 (3115)
	Total Unit Power (kW)		20.4	18.3	17.8
	¹ EER (Btuh/Watt)		10.0	11.5	11.5
	² Integrated Part Load Value (Btuh/Watt)		10.5	12.3	12.3
	Refrigerant Type		R-22	R-22	R-410A
Refrigerant Charge Furnished	Circuit 1		7 lbs. 0 oz. (3.18 kg)	11 lbs. 0 oz. (4.99 kg)	12 lbs. 8 oz. (5.67 kg)
	Circuit 2		7 lbs. 0 oz. (3.18 kg)	11 lbs. 0 oz. (4.99 kg)	12 lbs. 8 oz. (5.67 kg)
	Circuit 3		7 lbs. 0 oz. (3.18 kg)	11 lbs. 0 oz. (4.99 kg)	12 lbs. 0 oz. (5.44 kg)
	Circuit 4		7 lbs. 0 oz. (3.18 kg)	11 lbs. 0 oz. (4.99 kg)	12 lbs. 0 oz. (5.44 kg)
Refrigerant Charge Furnished with Humiditrol® Option	Circuit 1		Not Available	13 lbs. 0 oz. (5.90 kg)	12 lbs. 8 oz. (5.67 kg)
	Circuit 2		Not Available	13 lbs. 0 oz. (5.90 kg)	12 lbs. 8 oz. (5.67 kg)
	Circuit 3		Not Available	11 lbs. 0 oz. (4.99 kg)	12 lbs. 0 oz. (5.44 kg)
	Circuit 4		Not Available	11 lbs. 0 oz. (4.99 kg)	12 lbs. 0 oz. (5.44 kg)
Gas Heating Options Available - See page 18			Low (1 Stage), Standard (2 Stage), Medium (2 Stage), or High (2 Stage)		
Compressor Type (no.)			Scroll (4)	Scroll (4)	Scroll (4)
Outdoor Coils	Net face area - sq. ft. (m ²) total		56.5 (5.25)	56.5 (5.25)	56.5 (5.25)
	Tube diameter - in. (mm)		3/8 (9.5)	3/8 (9.5)	3/8 (9.5)
	Number of rows		1	2	2
	Fins per inch (m)		20 (787)	20 (787)	20 (787)
Outdoor Coil Fans	Motor horsepower (W)		(4) 1/3 (249)	(4) 1/3 (249)	(4) 1/3 (249)
	Motor rpm		1075	1075	1075
	Total Motor watts		1370	1395	1395
	Diameter - in. (mm)		(4) 24 (610)	(4) 24 (610)	(4) 24 (610)
	No. of blades		3	3	3
	Total Air volume - cfm (L/s)		15,850 (7480)	15,450 (7290)	15,450 (7290)
Indoor Coils	Net face area - sq. ft. (m ²) total		22.3 (2.07)	22.3 (2.07)	22.3 (2.07)
	Tube diameter - in. (mm)		3/8 (9.5)	3/8 (9.5)	3/8 (9.5)
	No. of rows		3	4	4
	Fins per inch (m)		14 (551)	14 (551)	14 (551)
	Drain connection - number and size		(1) 1 in. NPT coupling		
Expansion device type			Balanced Port Thermostatic Expansion Valve, removeable power head		
³ Indoor Blower and Drive Selection	Nominal motor output		3 hp (2.2 kW), 5 hp (3.7 kW), 7.5 hp (5.6 kW)		
	Maximum usable motor output (US Only)		3.45 hp (2.6 kW), 5.75 hp (4.3 kW), 8.63 hp (6.4 kW)		
	Motor - Drive kit number		3 hp kit #A - 535 - 725 rpm kit #1 - 685 - 865 rpm ⁴ kit #2 - 685 - 865 rpm	5 hp kit #2 - 685 - 865 rpm kit #3 - 850 - 1045 rpm kit #4 - 945 - 1185 rpm	7.5 hp kit# 5 - 945 - 1185 rpm kit# 6 - 1045 - 1285 rpm kit# 7 - 850 - 1045 rpm
Blower wheel nom. dia. x width - in. (mm)			(2) 15 x 15 (381 x 381)		
Filters	Type of filter		Disposable		
	No. and size - in. (mm)		(6) 24 x 24 x 2 (610 x 610 x 51)		
Electrical characteristics			208/230V, 460V or 575V - 60 hertz - 3 phase		

NOTE - Net capacity includes evaporator blower motor heat deduction. Gross capacity does not include evaporator blower motor heat deduction.
¹ Certified in accordance with the ULE certification program, which is based on ARI Standard 340/360; 95°F (35°C) outdoor air temperature and 80°F (27°C) db/67°F (19°C) wb entering evaporator air; minimum external duct static pressure.
² Integrated Part Load Value tested at 80°F (27°C) outdoor air temperature.
³ Using total air volume and system static pressure requirements determine from blower performance tables rpm and motor output required. Maximum usable output of motors furnished are shown. In Canada, nominal motor output is also maximum usable motor output. If motors of comparable output are used, be sure to keep within the service factor limitations outlined on the motor nameplate.
⁴ Drive Kit #2 is only used with 3 hp high efficiency motor only.

SPECIFICATIONS

20 TON

General Data		Nominal Tonnage	20 Ton LGC240S2B Standard	20 Ton LGA240H2B High	20 Ton LGA240H4B High	
		Model No.				
		Efficiency Type				
Cooling Performance	Gross Cooling Capacity - Btuh (kW)		243,000 (71.2)	252,000 (73.8)	240,000 (70.3)	
	¹ Net Cooling Capacity - Btuh (kW)		¹ 232,000 (67.9)	242,000 (70.9)	230,000 (67.4)	
	ARI Rated Air Flow - cfm (L/s)		8000 (3775)	7500 (3540)	7500 (3540)	
	Total Unit Power (kW)		24.4	22.0	20.9	
	¹ EER (Btuh/Watt)		¹ 9.5	11.0	11.0	
	² Integrated Part Load Value (Btuh/Watt)		9.8	11.8	12.0	
	Refrigerant Type		R-22	R-22	R-410A	
	Refrigerant Charge Furnished	Circuit 1		11 lbs. 0 oz. (4.99 kg)	11 lbs. 4 oz. (5.10 kg)	10 lbs. 8 oz. (4.76 kg)
		Circuit 2		11 lbs. 0 oz. (4.99 kg)	11 lbs. 4 oz. (5.10 kg)	10 lbs. 8 oz. (4.76 kg)
		Circuit 3		11 lbs. 0 oz. (4.99 kg)	11 lbs. 4 oz. (5.10 kg)	10 lbs. 8 oz. (4.76 kg)
Circuit 4			11 lbs. 0 oz. (4.99 kg)	11 lbs. 4 oz. (5.10 kg)	10 lbs. 8 oz. (4.76 kg)	
Refrigerant Charge Furnished with Humiditrol® Option	Circuit 1		Not Available	12 lbs. 4 oz. (5.56 kg)	11 lbs. 8 oz. (5.22 kg)	
	Circuit 2		Not Available	12 lbs. 4 oz. (5.56 kg)	11 lbs. 8 oz. (5.22 kg)	
	Circuit 3		Not Available	11 lbs. 4 oz. (5.10 kg)	10 lbs. 8 oz. (4.76 kg)	
	Circuit 4		Not Available	11 lbs. 4 oz. (5.10 kg)	10 lbs. 8 oz. (4.76 kg)	
Gas Heating Options Available - See page 18			Standard (2 Stage), Medium (2 Stage), or High (2 Stage)			
Compressor Type (no.)			Scroll (4)	Scroll (4)	Scroll (4)	
Outdoor Coils	Net face area - sq. ft. (m ²) total		56.5 (5.25)	56.5 (5.25)	56.5 (5.25)	
	Tube diameter - in. (mm)		3/8 (9.5)	3/8 (9.5)	3/8 (9.5)	
	Number of rows		2	2	2	
	Fins per inch (m)		20 (787)	20 (787)	20 (787)	
Outdoor Coil Fans	Motor horsepower (W)		(4) 1/3 (249)	(4) 1/3 (249)	(4) 1/3 (249)	
	Motor rpm		1075	1075	1075	
	Total Motor watts		1395	1395	1395	
	Diameter - in. (mm)		(4) 24 (610)	(4) 24 (610)	(4) 24 (610)	
	No. of blades		3	3	3	
	Total Air volume - cfm (L/s)		15,450 (7290)	15,450 (7290)	15,450 (7290)	
Indoor Coils	Net face area - sq. ft. (m ²) total		22.3 (2.07)	22.3 (2.07)	22.3 (2.07)	
	Tube diameter - in. (mm)		3/8 (9.5)	3/8 (9.5)	3/8 (9.5)	
	No. of rows		3	4	4	
	Fins per inch (m)		14 (551)	14 (551)	14 (551)	
	Drain connection - number and size		(1) 1 in. NPT coupling			
Expansion device type		Balanced Port Thermostatic Expansion Valve, removeable power head				
³ Indoor Blower and Drive Selection	Nominal motor output	5 hp (3.7 kW) - 7.5 hp (5.6 kW) - 10 hp (7.5 kW)				
	Maximum usable motor output (US Only)	5.75 hp (4.3 kW) - 8.63 hp (6.4 kW) - 11.5 hp (8.6 kW)				
	Motor - Drive kit number	5 hp kit #2 - 685 - 865 rpm kit #3 - 850 - 1045 rpm kit #4 945 - 1185 rpm	7.5 hp kit #5 - 945 - 1185 rpm kit #6 - 1045 - 1285 rpm kit #7 - 850 - 1045 rpm	10 hp kit #6 - 1045-1285 rpm kit #8 - 1135-1365 rpm		
Blower wheel nom. dia. x width - in. (mm)		(2) 15 x 15 (381 x 381)				
Filters	Type of filter	Disposable				
	No. and size - in. (mm)	(6) 24 x 24 x 2 (610 x 610 x 51)				
Electrical characteristics			208/230V, 460V or 575V - 60 hertz - 3 phase			

NOTE - Net capacity includes evaporator blower motor heat deduction. Gross capacity does not include evaporator blower motor heat deduction.

¹ Certified in accordance with the ULE certification program, which is based on ARI Standard 340/360; 95°F (35°C) outdoor air temperature and 80°F (27°C) db/67°F (19°C) wb entering evaporator air; minimum external duct static pressure.

² Integrated Part Load Value tested at 80°F (27°C) outdoor air temperature.

³ Using total air volume and system static pressure requirements determine from blower performance tables rpm and motor output required. Maximum usable output of motors furnished are shown. In Canada, nominal motor output is also maximum usable motor output. If motors of comparable output are used, be sure to keep within the service factor limitations outlined on the motor nameplate.

SPECIFICATIONS

25 TON

General Data		Nominal Tonnage (kW)	25 Ton LGC300S2B Standard	25 Ton LGC300S4B Standard	
		Model No.			
		Efficiency Type			
Cooling Performance	Gross Cooling Capacity - Btuh (kW)		302,000 (88.4)	294,000 (86.1)	
	¹ Net Cooling Capacity - Btuh (kW)		286,000 (83.7)	274,000 (80.2)	
	ARI Rated Air Flow - cfm (L/s)		9000 (4250)	9000 (4250)	
	Total Unit Power (kW)		30.1	28.8	
	¹ EER (Btuh/Watt)		9.5	9.5	
	² Integrated Part Load Value (Btuh/Watt)		9.7	9.7	
	Refrigerant Type		R-22	R-410A	
	Refrigerant Charge Furnished	Circuit 1	11 lbs. 4 oz. (5.10 kg)	11 lbs. 4 oz. (5.10 kg)	
		Circuit 2	11 lbs. 4 oz. (5.10 kg)	11 lbs. 4 oz. (5.10 kg)	
		Circuit 3	11 lbs. 4 oz. (5.10 kg)	11 lbs. 4 oz. (5.10 kg)	
Circuit 4		11 lbs. 4 oz. (5.10 kg)	11 lbs. 4 oz. (5.10 kg)		
Refrigerant Charge Furnished with Humiditrol® Option	Circuit 1	12 lbs. 4 oz. (5.56 kg)	11 lbs. 4 oz. (5.10 kg)		
	Circuit 2	12 lbs. 4 oz. (5.56 kg)	11 lbs. 4 oz. (5.10 kg)		
	Circuit 3	11 lbs. 4 oz. (5.10 kg)	11 lbs. 4 oz. (5.10 kg)		
	Circuit 4	11 lbs. 4 oz. (5.10 kg)	11 lbs. 4 oz. (5.10 kg)		
Gas Heating Options Available - See page 18			Standard (2 Stage), Medium (2 Stage), or High (2 Stage)		
Compressor Type (no.)			Scroll (4)	Scroll (4)	
Outdoor Coils	Net face area - sq. ft. (m ²) total		56.5 (5.25)	56.5 (5.25)	
	Tube diameter - in. (mm) - No. of rows		3/8 (9.5) - 2	3/8 (9.5) - 2	
	Fins per inch (m)		20 (787)	20 (787)	
Outdoor Coil Fans	Motor horsepower (W)		(4) 1/2 (373)	(4) 1/2 (373)	
	Motor rpm		1075	1075	
	Total Motor watts		1800	1800	
	Diameter - in. (mm) - No. of blades		(4) 24 (610) - 3	(4) 24 (610) - 3	
	Total Air volume - cfm (L/s)		16,000 (7550)	16,000 (7550)	
Indoor Coils	Net face area - sq. ft. (m ²) total		22.3 (2.07)	22.3 (2.07)	
	Tube diameter - in. (mm) - No. of rows		3/8 (9.5) - 4	3/8 (9.5) - 4	
	Fins per inch (m)		14 (551)	14 (551)	
	Drain connection - number and size		(1) 1 in. NPT coupling	(1) 1 in. NPT coupling	
	Expansion device type		Balanced Port Thermostatic Expansion Valve, removeable power head		
³ Indoor Blower and Drive Selection	Nominal motor output		5 hp (3.7 kW) - 7.5 hp (5.6 kW) - 10 hp (7.5 kW)		
	Max. usable motor output (US Only)		5.75 hp (4.3 kW) - 8.63 hp (6.4 kW) - 11.5 hp (8.6 kW)		
	Motor - Drive kit		5 hp kit #2 - 685 - 865 rpm kit #3 - 850 - 1045 rpm kit #4 - 945 - 1185 rpm	7.5 hp kit# 5 - 945 - 1185 rpm kit# 6 - 1045 - 1285 rpm kit# 7 - 850 - 1045 rpm	10 hp kit #6 - 1045-1285 rpm kit #8 - 1135-1365 rpm
	Blower wheel nominal diameter x width		(2) 15 x 15 (381 x 381)	(2) 15 x 15 (381 x 381)	
Filters	Type of filter		Disposable		
	Number and size - in. (mm)		(6) 24 x 24 x 2 (610 x 610 x 51)	(6) 24 x 24 x 2 (610 x 610 x 51)	
Electrical characteristics			208/230V, 460V or 575V - 60 hertz - 3 phase		

NOTE - Net capacity includes evaporator blower motor heat deduction. Gross capacity does not include evaporator blower motor heat deduction.
¹ Tested at conditions included in with ARI Standard 340/360; 95°F (35°C) outdoor air temperature and 80°F (27°C) db/67°F (19°C) wb entering evaporator air; minimum external duct static pressure.
² Integrated Part Load Value tested at 80°F (27°C) outdoor air temperature.
³ Using total air volume and system static pressure requirements determine from blower performance tables rpm and motor output required. Maximum usable output of motors furnished are shown. In Canada, nominal motor output is also maximum usable motor output. If motors of comparable output are used, be sure to keep within the service factor limitations outlined on the motor nameplate.

SPECIFICATIONS - GAS HEAT

Usage Data		Model No.	-156, -180, -210	-156, -180, -210, -240, -300	-180, -210, -240, -300	
Gas Heating Performance	Heat Input Type		Low (1 Stage)	Standard (2 Stage)	Medium (2 Stage)	High (2 Stage)
	Input - Btuh (KW)	First Stage	169,000 (49.5)	169,000 (49.5)	234,000 (68.6)	312,000 (91.4)
		Second Stage	---	260,000 (76.2)	360,000 (105.5)	480,000 (140.6)
	Output - Btuh (kW)	First Stage	135,000 (39.6)	---	---	---
		Second Stage	---	208,000 (60.9)	288,000 (84.4)	384,000 (112.5)
	CSA Thermal Efficiency		80.0%			
Gas Supply Connections		1 in. npt				
Recommended Gas Supply Pressure - Natural		7 in. w.g. (1.7 kPa)				
LPG/Propane		11 in. w.g. (2.7 kPa)				

HIGH ALTITUDE DERATE

Units may be installed at altitudes up to 2000 feet (610 m) above sea level without any modification. At altitudes above 2000 feet (610 m), units must be derated to match gas manifold pressures shown in table below. NOTE - This is the only permissible derate for these units.

	Altitude		Gas Manifold Pressure				Input Rate			
	ft.	m	Natural Gas		LPG/Propane		Natural Gas		LPG / Propane	
			in. w.g.	kPa	in. w.g.	kPa	Btuh	kW	Btuh	kW
Standard	2001 - 4500	610 - 1372	3.4	0.85	9.6	2.39	260,000	76.1	249,000	72.9
Medium	2001 - 4500	610 - 1372	3.4	0.85	9.6	2.39	360,000	105.4	345,000	101.0
High	2001 - 4500	610 - 1372	3.4	0.85	9.6	2.39	480,000	140.5	460,000	134.7

COOLING RATINGS

NOTE - For Temperatures and Capacities not shown in tables, see bulletin — Cooling Unit Rating Table Correction Factor Data in Miscellaneous Engineering Data section.

13 TON HIGH EFFICIENCY (R-22) TWO COMPRESSORS OPERATING

LGC156H2

Entering Wet Bulb Temperature	Total Air Volume		Outdoor Air Temperature Entering Outdoor Coil																							
			65°F (18°C)						75°F (24°C)						85°F (29°C)						95°F (35°C)					
			Total Cooling Capacity		Comp Motor kW Input	Sensible To Total Ratio (S/T) Dry Bulb			Total Cooling Capacity		Comp Motor kW Input	Sensible To Total Ratio (S/T) Dry Bulb			Total Cooling Capacity		Comp Motor kW Input	Sensible To Total Ratio (S/T) Dry Bulb			Total Cooling Capacity		Comp Motor kW Input	Sensible To Total Ratio (S/T) Dry Bulb		
			kBtuh	kW		75°F 24°C	80°F 27°C	85°F 29°C	kBtuh	kW		75°F 24°C	80°F 27°C	85°F 29°C	kBtuh	kW		75°F 24°C	80°F 27°C	85°F 29°C	kBtuh	kW		75°F 24°C	80°F 27°C	85°F 29°C
63°F (17°C)	4160	1965	105.6	30.9	4.67	.64	.79	.94	102.8	30.1	5.27	.64	.80	.96	99.6	29.2	5.95	.65	.82	.97	96.1	28.2	6.71	.66	.83	.99
	5200	2455	110.2	32.3	4.69	.69	.87	1.00	107.2	31.4	5.29	.70	.89	1.00	103.8	30.4	5.97	.71	.90	1.00	99.9	29.3	6.74	.73	.93	1.00
	6240	2945	113.9	33.4	4.71	.74	.94	1.00	110.7	32.4	5.31	.76	.96	1.00	107.2	31.4	5.99	.77	.98	1.00	103.5	30.3	6.75	.79	.99	1.00
67°F (19°C)	4160	1965	113.2	33.2	4.70	.50	.61	.74	110.0	32.2	5.30	.51	.62	.76	106.4	31.2	5.99	.51	.63	.77	102.5	30.0	6.74	.52	.64	.79
	5200	2455	117.3	34.4	4.73	.53	.66	.82	114.0	33.4	5.32	.53	.67	.84	110.1	32.3	6.00	.54	.68	.86	106.0	31.1	6.76	.55	.70	.89
	6240	2945	120.4	35.3	4.75	.55	.71	.91	116.8	34.2	5.34	.56	.73	.92	112.8	33.1	6.02	.57	.75	.94	108.5	31.8	6.78	.58	.77	.97
71°F (22°C)	4160	1965	121.4	35.6	4.75	.38	.48	.59	117.9	34.6	5.34	.38	.49	.59	114.1	33.4	6.02	.38	.49	.60	109.8	32.2	6.78	.38	.50	.61
	5200	2455	125.7	36.8	4.77	.39	.51	.63	121.9	35.7	5.36	.39	.52	.64	117.8	34.5	6.03	.39	.52	.65	113.3	33.2	6.80	.40	.53	.67
	6240	2945	128.7	37.7	4.79	.40	.54	.68	124.7	36.5	5.38	.40	.55	.70	120.4	35.3	6.05	.40	.55	.72	115.7	33.9	6.81	.41	.56	.74

13 TON HIGH EFFICIENCY (R-22) ALL COMPRESSORS OPERATING

LGC156H2

Entering Wet Bulb Temperature	Total Air Volume		Outdoor Air Temperature Entering Outdoor Coil																							
			85°F (29°C)						95°F (35°C)						105°F (41°C)						115°F (46°C)					
			Total Cooling Capacity		Comp Motor kW Input	Sensible To Total Ratio (S/T) Dry Bulb			Total Cooling Capacity		Comp Motor kW Input	Sensible To Total Ratio (S/T) Dry Bulb			Total Cooling Capacity		Comp Motor kW Input	Sensible To Total Ratio (S/T) Dry Bulb			Total Cooling Capacity		Comp Motor kW Input	Sensible To Total Ratio (S/T) Dry Bulb		
			kBtuh	kW		75°F 24°C	80°F 27°C	85°F 29°C	kBtuh	kW		75°F 24°C	80°F 27°C	85°F 29°C	kBtuh	kW		75°F 24°C	80°F 27°C	85°F 29°C	kBtuh	kW		75°F 24°C	80°F 27°C	85°F 29°C
63°F (17°C)	4160	1965	150.4	44.1	9.03	.68	.84	.98	145.1	42.5	10.18	.69	.85	1.00	139.2	40.8	11.51	.70	.87	1.00	132.9	38.9	12.98	.72	.90	1.00
	5200	2455	156.7	45.9	9.06	.74	.92	1.00	150.9	44.2	10.22	.75	.94	1.00	144.8	42.4	11.54	.77	.96	1.00	138.5	40.6	13.01	.79	.99	1.00
	6240	2945	161.9	47.4	9.09	.80	.99	1.00	156.3	45.8	10.25	.82	1.00	1.00	150.7	44.2	11.54	.84	1.00	1.00	144.5	42.3	13.02	.87	1.00	1.00
67°F (19°C)	4160	1965	160.7	47.1	9.09	.53	.66	.79	154.8	45.4	10.24	.54	.67	.81	148.5	43.5	11.54	.55	.68	.83	141.6	41.5	13.01	.56	.70	.86
	5200	2455	166.2	48.7	9.12	.56	.71	.88	160.0	46.9	10.26	.57	.72	.90	153.3	44.9	11.58	.58	.74	.93	145.9	42.8	13.05	.59	.77	.95
	6240	2945	170.2	49.9	9.14	.59	.77	.96	163.7	48.0	10.29	.60	.79	.98	156.6	45.9	11.60	.62	.81	1.00	149.2	43.7	13.07	.63	.84	1.00
71°F (22°C)	4160	1965	172.2	50.5	9.15	.40	.52	.63	165.8	48.6	10.29	.40	.52	.64	159.0	46.6	11.59	.41	.53	.66	151.7	44.5	13.07	.41	.54	.67
	5200	2455	177.8	52.1	9.17	.41	.55	.69	171.0	50.1	10.32	.41	.56	.70	163.6	47.9	11.64	.42	.57	.72	155.8	45.7	13.10	.42	.58	.74
	6240	2945	181.6	53.2	9.19	.42	.58	.74	174.6	51.2	10.34	.43	.59	.76	166.9	48.9	11.64	.43	.60	.79	158.7	46.5	13.12	.44	.62	.81

13 TON HIGH EFFICIENCY (R-410A) TWO COMPRESSORS OPERATING

LGC156H4

Entering Wet Bulb Temperature	Total Air Volume		Outdoor Air Temperature Entering Outdoor Coil																							
			65°F (18°C)						75°F (24°C)						85°F (29°C)						95°F (35°C)					
			Total Cooling Capacity		Comp Motor kW Input	Sensible To Total Ratio (S/T) Dry Bulb			Total Cooling Capacity		Comp Motor kW Input	Sensible To Total Ratio (S/T) Dry Bulb			Total Cooling Capacity		Comp Motor kW Input	Sensible To Total Ratio (S/T) Dry Bulb			Total Cooling Capacity		Comp Motor kW Input	Sensible To Total Ratio (S/T) Dry Bulb		
			kBtuh	kW		75°F 24°C	80°F 27°C	85°F 29°C	kBtuh	kW		75°F 24°C	80°F 27°C	85°F 29°C	kBtuh	kW		75°F 24°C	80°F 27°C	85°F 29°C	kBtuh	kW		75°F 24°C	80°F 27°C	85°F 29°C
63°F (17°C)	4160	1965	108.9	31.9	4.44	.66	.80	.94	105.4	30.9	5.04	.66	.81	.96	101.7	29.8	5.72	.67	.83	.97	97.7	28.6	6.47	.69	.85	.99
	5200	2455	113.4	33.2	4.45	.71	.88	1.00	109.9	32.2	5.06	.72	.89	1.00	105.9	31.0	5.74	.73	.91	1.00	101.7	29.8	6.49	.75	.94	1.00
	6240	2945	117.1	34.3	4.47	.76	.95	1.00	113.3	33.2	5.08	.78	.96	1.00	109.4	32.1	5.75	.79	.98	1.00	105.2	30.8	6.51	.82	1.00	1.00
67°F (19°C)	4160	1965	116.5	34.1	4.47	.52	.63	.76	112.7	33.0	5.08	.52	.64	.77	108.7	31.9	5.75	.53	.65	.79	104.3	30.6	6.51	.53	.66	.81
	5200	2455	120.7	35.4	4.49	.54	.68	.84	116.7	34.2	5.09	.55	.69	.85	112.4	32.9	5.77	.56	.70	.87	107.7	31.6	6.53	.57	.72	.90
	6240	2945	123.7	36.3	4.51	.57	.73	.91	119.5	35.0	5.11	.58	.75	.93	115.1	33.7	5.79	.59	.77	.95	110.2	32.3	6.53	.60	.79	.97
71°F (22°C)	4160	1965	124.7	36.5	4.51	.39	.50	.61	120.7	35.4	5.11	.40	.50	.62	116.3	34.1	5.79	.40	.51	.62	111.6	32.7	6.54	.40	.52	.64
	5200	2455	129.0	37.8	4.53	.40	.53	.65	124.7	36.5	5.13	.40	.53	.67	120.1	35.2	5.80	.41	.54	.68	115.1	33.7	6.55	.41	.55	.69
	6240	2945	132.0	38.7	4.54	.41	.56	.71	127.5	37.4	5.15	.42	.57	.72	122.7	36.0	5.81	.42	.57	.74	117.4	34.4	6.57	.42	.59	.76

13 TON HIGH EFFICIENCY (R-410A) ALL COMPRESSORS OPERATING

LGC156H4

Entering Wet Bulb Temperature	Total Air Volume		Outdoor Air Temperature Entering Outdoor Coil																							
			85°F (29°C)						95°F (35°C)						105°F (41°C)						115°F (46°C)					
			Total Cooling Capacity		Comp Motor kW Input	Sensible To Total Ratio (S/T) Dry Bulb			Total Cooling Capacity		Comp Motor kW Input	Sensible To Total Ratio (S/T) Dry Bulb			Total Cooling Capacity		Comp Motor kW Input	Sensible To Total Ratio (S/T) Dry Bulb			Total Cooling Capacity		Comp Motor kW Input	Sensible To Total Ratio (S/T) Dry Bulb		
			kBtuh	kW		75°F 24°C	80°F 27°C	85°F 29°C	kBtuh	kW		75°F 24°C	80°F 27°C	85°F 29°C	kBtuh	kW		75°F 24°C	80°F 27°C	85°F 29°C	kBtuh	kW		75°F 24°C	80°F 27°C	85°F 29°C
63°F (17°C)	4160	1965	150.6	44.1	8.68	.70	.84	.98	144.8	42.4	9.81	.71	.86	.99	138.4	40.6	11.09	.72	.88	1.00	131.7	38.6	12.56	.74	.91	1.00
	5200	2455	156.7	45.9	8.70	.75	.92	1.00	150.5	44.1	9.84	.77	.94	1.00	144.0	42.2	11.13	.79	.97	1.00	137.3	40.2	12.61	.81	.99	1.00
	6240	2945	161.9	47.4	8.72	.81	.99	1.00	156.0	45.7	9.86	.83	1.00	1.00	149.9	43.9	11.14	.85	1.00	1.00	143.3	42.0	12.61	.88	1.00	1.00
67°F (19°C)	4160	1965	160.7	47.1	8.71	.55	.67	.80	154.3	45.2	9.85	.55	.68	.82	147.6	43.3	11.13	.56	.70	.85	140.3	41.1	12.62	.57	.71	.87
	5200	2455	166.1	48.7	8.74	.58	.73	.89	159.4	46.7	9.88	.58	.74	.91	152.4	44.7	11.17	.59	.76	.93	144.5	42.3	12.64	.61	.78	.96
	6240	2945	170.1	49.9	8.77	.61	.78	.96	163.1	47.8	9.89	.62	.80	.98	155.7	45.6	11.19	.63	.83	.99	147.8	43.3	12.65	.65	.85	1.00
71°F (22°C)	4160	1965	172.1	50.4	8.77	.41	.53	.65	165.3	48.4	9.90	.41	.54	.66	158.1	46.3	11.19	.41	.54	.67	150.4	44.1	12.67	.42	.55	.69
	5200	2455	177.7	52.1	8.80	.42	.56	.70	170.4	49.9	9.94	.42	.57	.72	162.6	47.7	11.22	.43	.58	.73	154.4	45.3	12.68	.43	.60	.76
	6240	2945	181.4	53.2	8.82	.43	.60	.76	173.9	51.0	9.95	.44	.61	.78	165.8	48.6	11.22	.44	.62	.80	157.3	46.1	12.70	.45	.64	.83

COOLING RATINGS

NOTE - For Temperatures and Capacities not shown in tables, see bulletin — Cooling Unit Rating Table Correction Factor Data in Miscellaneous Engineering Data section.

15 TON STANDARD EFFICIENCY (R-22) TWO COMPRESSORS OPERATING

LGC180S2

Entering Wet Bulb Temperature	Total Air Volume		Outdoor Air Temperature Entering Outdoor Coil																							
			65°F (18°C)						75°F (24°C)						85°F (29°C)						95°F (35°C)					
	Total Cooling Capacity		Comp Motor kW Input	Sensible To Total Ratio (S/T) Dry Bulb			Total Cooling Capacity		Comp Motor kW Input	Sensible To Total Ratio (S/T) Dry Bulb			Total Cooling Capacity		Comp Motor kW Input	Sensible To Total Ratio (S/T) Dry Bulb			Total Cooling Capacity		Comp Motor kW Input	Sensible To Total Ratio (S/T) Dry Bulb				
	kBtuh	kW		75°F 24°C	80°F 27°C	85°F 29°C	kBtuh	kW		75°F 24°C	80°F 27°C	85°F 29°C	kBtuh	kW		75°F 24°C	80°F 27°C	85°F 29°C	kBtuh	kW		75°F 24°C	80°F 27°C	85°F 29°C		
63°F (17°C)	4800	2265	123.4	36.2	7.02	.66	.80	.94	120.2	35.2	7.72	.67	.81	.95	116.3	34.1	8.52	.68	.83	.97	112.1	32.9	9.45	.69	.85	.98
	6000	2830	128.2	37.6	7.13	.71	.88	1.00	124.8	36.6	7.82	.72	.89	1.00	120.8	35.4	8.62	.73	.91	1.00	116.5	34.1	9.55	.75	.93	1.00
	7200	3400	132.0	38.7	7.20	.77	.94	1.00	128.5	37.7	7.90	.78	.96	1.00	124.5	36.5	8.71	.79	.97	1.00	120.2	35.2	9.63	.81	.99	1.00
67°F (19°C)	4800	2265	131.2	38.5	7.18	.53	.64	.77	127.7	37.4	7.88	.53	.65	.78	123.7	36.3	8.69	.53	.65	.79	119.2	34.9	9.61	.54	.66	.81
	6000	2830	135.4	39.7	7.28	.55	.69	.84	131.8	38.6	7.98	.55	.69	.86	127.6	37.4	8.78	.56	.71	.87	123.0	36.0	9.71	.57	.72	.89
	7200	3400	138.3	40.5	7.34	.58	.74	.91	134.7	39.5	8.04	.58	.75	.93	130.4	38.2	8.85	.59	.77	.95	125.6	36.8	9.79	.60	.79	.96
71°F (22°C)	4800	2265	139.5	40.9	7.36	.48	.51	.62	136.0	39.9	8.06	.48	.51	.62	131.8	38.6	8.87	.48	.52	.63	127.1	37.2	9.82	.48	.52	.64
	6000	2830	143.7	42.1	7.46	.41	.54	.66	140.0	41.0	8.16	.41	.54	.67	135.6	39.7	8.97	.41	.55	.68	130.8	38.3	9.90	.41	.55	.70
	7200	3400	146.5	42.9	7.53	.42	.57	.72	142.8	41.9	8.22	.42	.57	.73	138.2	40.5	9.03	.42	.58	.74	133.1	39.0	9.98	.43	.59	.76

15 TON STANDARD EFFICIENCY (R-22) ALL COMPRESSORS OPERATING

LGC180S2

Entering Wet Bulb Temperature	Total Air Volume		Outdoor Air Temperature Entering Outdoor Coil																							
			85°F (29°C)						95°F (35°C)						105°F (41°C)						115°F (46°C)					
	Total Cooling Capacity		Comp Motor kW Input	Sensible To Total Ratio (S/T) Dry Bulb			Total Cooling Capacity		Comp Motor kW Input	Sensible To Total Ratio (S/T) Dry Bulb			Total Cooling Capacity		Comp Motor kW Input	Sensible To Total Ratio (S/T) Dry Bulb			Total Cooling Capacity		Comp Motor kW Input	Sensible To Total Ratio (S/T) Dry Bulb				
	kBtuh	kW		75°F 24°C	80°F 27°C	85°F 29°C	kBtuh	kW		75°F 24°C	80°F 27°C	85°F 29°C	kBtuh	kW		75°F 24°C	80°F 27°C	85°F 29°C	kBtuh	kW		75°F 24°C	80°F 27°C	85°F 29°C		
63°F (17°C)	4800	2265	176.3	51.7	12.81	.69	.84	.97	169.9	49.8	14.20	.70	.85	.98	163.3	47.9	15.75	.71	.87	1.00	156.8	46.0	17.52	.73	.89	1.00
	6000	2830	183.2	53.7	12.96	.74	.91	1.00	176.6	51.8	14.35	.76	.93	1.00	169.6	49.7	15.93	.78	.95	1.00	162.9	47.7	17.73	.79	.97	1.00
	7200	3400	188.8	55.3	13.09	.80	.97	1.00	182.2	53.4	14.48	.82	.99	1.00	175.5	51.4	16.08	.84	1.00	1.00	169.1	49.6	17.91	.86	1.00	1.00
67°F (19°C)	4800	2265	187.6	55.0	13.06	.54	.67	.80	180.7	53.0	14.45	.55	.68	.82	173.6	50.9	16.05	.56	.69	.83	166.5	48.8	17.83	.56	.70	.85
	6000	2830	193.5	56.7	13.20	.57	.72	.88	186.4	54.6	14.60	.58	.73	.90	178.8	52.4	16.19	.59	.75	.92	171.4	50.2	18.01	.60	.77	.94
	7200	3400	197.7	57.9	13.31	.60	.78	.95	190.4	55.8	14.72	.61	.80	.97	182.6	53.5	16.31	.62	.82	.98	174.8	51.2	18.11	.64	.84	1.00
71°F (22°C)	4800	2265	199.8	58.6	13.34	.41	.53	.64	192.6	56.4	14.76	.41	.53	.66	185.1	54.2	16.37	.41	.54	.67	177.5	52.0	18.18	.42	.55	.68
	6000	2830	205.6	60.3	13.49	.42	.56	.70	198.2	58.1	14.89	.42	.57	.71	190.3	55.8	16.51	.43	.58	.73	182.1	53.4	18.36	.43	.59	.74
	7200	3400	209.5	61.4	13.58	.43	.59	.75	201.8	59.1	15.01	.43	.60	.77	193.8	56.8	16.61	.44	.61	.79	185.3	54.3	18.45	.44	.63	.81

15 TON HIGH EFFICIENCY (R-22) TWO COMPRESSORS OPERATING

LGC180H2

Entering Wet Bulb Temperature	Total Air Volume		Outdoor Air Temperature Entering Outdoor Coil																							
			65°F (18°C)						75°F (24°C)						85°F (29°C)						95°F (35°C)					
	Total Cooling Capacity		Comp Motor kW Input	Sensible To Total Ratio (S/T) Dry Bulb			Total Cooling Capacity		Comp Motor kW Input	Sensible To Total Ratio (S/T) Dry Bulb			Total Cooling Capacity		Comp Motor kW Input	Sensible To Total Ratio (S/T) Dry Bulb			Total Cooling Capacity		Comp Motor kW Input	Sensible To Total Ratio (S/T) Dry Bulb				
	kBtuh	kW		75°F 24°C	80°F 27°C	85°F 29°C	kBtuh	kW		75°F 24°C	80°F 27°C	85°F 29°C	kBtuh	kW		75°F 24°C	80°F 27°C	85°F 29°C	kBtuh	kW		75°F 24°C	80°F 27°C	85°F 29°C		
63°F (17°C)	4800	2265	128.6	37.7	5.78	.66	.80	.93	125.2	36.7	6.47	.67	.81	.94	121.4	35.6	7.29	.67	.82	.96	117.2	34.3	8.22	.68	.84	.97
	6000	2830	133.8	39.2	5.82	.71	.87	.99	130.0	38.1	6.52	.72	.88	1.00	126.1	37.0	7.32	.73	.90	1.00	121.8	35.7	8.26	.74	.91	1.00
	7200	3400	137.6	40.3	5.85	.76	.93	1.00	133.9	39.2	6.54	.77	.95	1.00	129.9	38.1	7.36	.78	.96	1.00	125.4	36.8	8.29	.80	.98	1.00
67°F (19°C)	4800	2265	137.0	40.2	5.84	.52	.64	.76	133.3	39.1	6.53	.53	.64	.77	129.1	37.8	7.35	.53	.65	.78	124.7	36.5	8.30	.54	.66	.80
	6000	2830	141.7	41.5	5.87	.55	.68	.83	137.7	40.4	6.58	.55	.69	.84	133.3	39.1	7.39	.56	.70	.86	128.6	37.7	8.32	.57	.72	.88
	7200	3400	145.1	42.5	5.91	.57	.73	.90	140.9	41.3	6.61	.58	.74	.91	136.3	39.9	7.41	.59	.76	.93	131.4	38.5	8.35	.60	.78	.95
71°F (22°C)	4800	2265	146.2	42.8	5.91	.40	.51	.61	142.0	41.6	6.61	.40	.51	.62	137.7	40.4	7.42	.40	.51	.63	132.9	38.9	8.37	.40	.52	.64
	6000	2830	150.9	44.2	5.95	.41	.53	.66	146.5	42.9	6.65	.41	.54	.67	141.8	41.6	7.46	.41	.54	.68	136.8	40.1	8.40	.41	.55	.69
	7200	3400	154.1	45.2	5.98	.42	.56	.71	149.6	43.8	6.68	.42	.57	.72	144.8	42.4	7.48	.42	.57	.73	139.6	40.9	8.43	.42	.58	.75

15 TON HIGH EFFICIENCY (R-22) ALL COMPRESSORS OPERATING

LGC180H2

Entering Wet Bulb Temperature	Total Air Volume		Outdoor Air Temperature Entering Outdoor Coil																							
			85°F (29°C)						95°F (35°C)						105°F (41°C)						115°F (46°C)					
	Total Cooling Capacity		Comp Motor kW Input	Sensible To Total Ratio (S/T) Dry Bulb			Total Cooling Capacity		Comp Motor kW Input	Sensible To Total Ratio (S/T) Dry Bulb			Total Cooling Capacity		Comp Motor kW Input	Sensible To Total Ratio (S/T) Dry Bulb			Total Cooling Capacity		Comp Motor kW Input	Sensible To Total Ratio (S/T) Dry Bulb				
	kBtuh	kW		75°F 24°C	80°F 27°C	85°F 29°C	kBtuh	kW		75°F 24°C	80°F 27°C	85°F 29°C	kBtuh	kW		75°F 24°C	80°F 27°C	85°F 29°C	kBtuh	kW		75°F 24°C	80°F 27°C	85°F 29°C		
63°F (17°C)	4800	2265	177.6	52.0	10.86	.69	.82	.96	171.5	50.3	12.26	.69	.84	.97	165.1	48.4	13.86	.70	.85	.99	158.3	46.4	15.67	.72	.88	1.00
	6000	2830	184.4	54.0	10.92	.73	.90	1.00	178.1	52.2	12.31	.75	.92	1.00	171.4	50.2	13.91	.76	.93	1.00	164.3	48.2	15.75	.78	.96	1.00
	7200	3400	189.9	55.7	10.96	.79	.96	1.00	183.6	53.8	12.36	.80	.98	1.00	176.9	51.8	13.97	.82	.99	1.00	170.3	49.9	15.78	.84	1.00	1.00
67°F (19°C)	4800	2265	188.9	55.4	10.96	.54	.66	.79	182.3	53.4	12.36	.54	.67	.80	175.4	51.4	13.97	.55	.68	.82	168.2	49.3	15.78	.56	.69	.84
	6000	2830	195.0	57.1	11.02	.57	.71	.86	188.1	55.1	12.40	.57	.72	.88	180.9	53.0	14.00	.58	.74	.90	173.2	50.8	15.84	.59	.76	.92
	7200	3400	199.5	58.5	11.05	.60	.76	.93	192.3	56.4	12.46	.60	.78	.95	184.8	54.2	14.06	.61	.80	.97	176.8	51.8	15.90	.63	.82	.99
71°F (22°C)	4800	2265	201.4	59.0	11.06	.41	.52	.64	194.5	57.0	12.47	.41	.53	.64	187.0	54.8	14.09	.41	.53	.66	179.4	52.6	15.91	.41	.54	.67
	6000	2830	207.6	60.8	11.13	.42	.55	.69	200.2	58.7	12.52	.42	.56	.70	192.5	56.4	14.13	.42	.57	.71	184.4	54.0	15.96	.43	.58	.73
	7200	3400	211.8	62.1	11.17	.43	.58	.74	204.1	59.8	12.56	.43	.59	.76	196.0	57.4	14.19	.44	.60	.78	187.6	55.0	16.01	.44	.62	.80

COOLING RATINGS

NOTE - For Temperatures and Capacities not shown in tables, see bulletin — Cooling Unit Rating Table Correction Factor Data in Miscellaneous Engineering Data section.

15 TON HIGH EFFICIENCY (R-410A) TWO COMPRESSORS OPERATING

LGC180H4

Entering Wet Bulb Temperature	Total Air Volume		Outdoor Air Temperature Entering Outdoor Coil																							
			65°F (18°C)						75°F (24°C)						85°F (29°C)						95°F (35°C)					
			Total Cooling Capacity	Comp Motor kW Input	Sensible To Total Ratio (S/T) Dry Bulb			Total Cooling Capacity	Comp Motor kW Input	Sensible To Total Ratio (S/T) Dry Bulb			Total Cooling Capacity	Comp Motor kW Input	Sensible To Total Ratio (S/T) Dry Bulb			Total Cooling Capacity	Comp Motor kW Input	Sensible To Total Ratio (S/T) Dry Bulb						
					75°F 24°C	80°F 27°C	85°F 29°C			75°F 24°C	80°F 27°C	85°F 29°C			75°F 24°C	80°F 27°C	85°F 29°C			75°F 24°C	80°F 27°C	85°F 29°C				
cfm	L/s	kBtuh	kW	kBtuh	kW	kBtuh	kW	kBtuh	kW	kBtuh	kW	kBtuh	kW	kBtuh	kW	kBtuh	kW	kBtuh	kW	kBtuh	kW					
63°F (17°C)	4800	2265	129.7	38.0	5.51	.66	.79	.92	125.0	36.6	6.30	.67	.81	.94	119.9	35.1	7.15	.68	.82	.96	114.4	33.5	8.15	.69	.85	.98
	6000	2830	135.1	39.6	5.55	.70	.86	.98	130.0	38.1	6.32	.71	.88	.99	124.7	36.5	7.19	.73	.90	1.00	118.9	34.8	8.18	.75	.93	1.00
	7200	3400	139.3	40.8	5.57	.75	.93	1.00	134.1	39.3	6.36	.77	.95	1.00	128.6	37.7	7.22	.79	.96	1.00	122.9	36.0	8.22	.81	.98	1.00
67°F (19°C)	4800	2265	138.5	40.6	5.56	.52	.63	.75	133.2	39.0	6.35	.53	.64	.77	127.7	37.4	7.21	.53	.65	.79	121.7	35.7	8.21	.54	.67	.81
	6000	2830	143.4	42.0	5.60	.54	.68	.83	137.8	40.4	6.38	.55	.69	.84	131.9	38.7	7.25	.56	.70	.87	125.6	36.8	8.24	.57	.72	.89
	7200	3400	146.8	43.0	5.62	.57	.73	.89	141.0	41.3	6.41	.58	.74	.91	134.9	39.5	7.28	.59	.76	.94	128.4	37.6	8.27	.60	.79	.96
71°F (22°C)	4800	2265	147.8	43.3	5.63	.40	.50	.61	142.2	41.7	6.41	.40	.51	.62	136.3	39.9	7.29	.40	.51	.63	130.0	38.1	8.28	.40	.52	.64
	6000	2830	152.7	44.8	5.67	.40	.53	.65	146.8	43.0	6.46	.41	.54	.67	140.5	41.2	7.33	.41	.54	.68	133.8	39.2	8.32	.41	.56	.70
	7200	3400	156.2	45.8	5.70	.41	.56	.70	149.9	43.9	6.49	.42	.57	.72	143.5	42.1	7.36	.42	.58	.74	136.4	40.0	8.35	.43	.59	.76

15 TON HIGH EFFICIENCY (R-410A) ALL COMPRESSORS OPERATING

LGC180H4

Entering Wet Bulb Temperature	Total Air Volume		Outdoor Air Temperature Entering Outdoor Coil																							
			85°F (29°C)						95°F (35°C)						105°F (41°C)						115°F (46°C)					
			Total Cooling Capacity	Comp Motor kW Input	Sensible To Total Ratio (S/T) Dry Bulb			Total Cooling Capacity	Comp Motor kW Input	Sensible To Total Ratio (S/T) Dry Bulb			Total Cooling Capacity	Comp Motor kW Input	Sensible To Total Ratio (S/T) Dry Bulb			Total Cooling Capacity	Comp Motor kW Input	Sensible To Total Ratio (S/T) Dry Bulb						
					75°F 24°C	80°F 27°C	85°F 29°C			75°F 24°C	80°F 27°C	85°F 29°C			75°F 24°C	80°F 27°C	85°F 29°C			75°F 24°C	80°F 27°C	85°F 29°C				
cfm	L/s	kBtuh	kW	kBtuh	kW	kBtuh	kW	kBtuh	kW	kBtuh	kW	kBtuh	kW	kBtuh	kW	kBtuh	kW	kBtuh	kW	kBtuh	kW					
63°F (17°C)	4800	2265	179.9	52.7	10.73	.69	.83	.97	171.7	50.3	12.22	.70	.85	.98	162.7	47.7	13.92	.71	.88	.99	152.8	44.8	15.92	.73	.91	1.00
	6000	2830	187.1	54.8	10.79	.74	.91	1.00	178.3	52.3	12.27	.76	.93	1.00	169.1	49.6	13.98	.78	.96	1.00	159.3	46.7	15.97	.81	.98	1.00
	7200	3400	193.0	56.6	10.84	.79	.97	1.00	184.4	54.0	12.33	.82	.99	1.00	175.3	51.4	14.04	.84	.99	1.00	165.7	48.6	16.03	.88	1.00	1.00
67°F (19°C)	4800	2265	191.6	56.2	10.82	.54	.66	.79	182.5	53.5	12.30	.55	.67	.81	172.9	50.7	14.02	.55	.69	.84	162.2	47.5	16.01	.57	.71	.87
	6000	2830	197.8	58.0	10.88	.57	.71	.87	188.3	55.2	12.36	.58	.73	.90	178.1	52.2	14.08	.59	.75	.93	166.9	48.9	16.05	.60	.78	.96
	7200	3400	202.3	59.3	10.93	.60	.77	.94	192.5	56.4	12.41	.61	.79	.96	181.9	53.3	14.12	.62	.82	.98	170.5	50.0	16.10	.64	.85	.99
71°F (22°C)	4800	2265	204.4	59.9	10.95	.40	.52	.64	194.9	57.1	12.43	.41	.53	.65	184.6	54.1	14.13	.41	.54	.67	173.1	50.7	16.12	.41	.55	.69
	6000	2830	210.7	61.7	11.00	.41	.55	.69	200.6	58.8	12.48	.42	.56	.71	189.5	55.5	14.21	.42	.58	.73	177.6	52.0	16.16	.43	.59	.76
	7200	3400	215.0	63.0	11.05	.43	.58	.74	204.3	59.9	12.54	.43	.60	.77	192.9	56.5	14.24	.44	.61	.80	180.6	52.9	16.20	.45	.63	.83

17.5 TON STANDARD EFFICIENCY (R-22) TWO COMPRESSORS OPERATING

LGC210S2

Entering Wet Bulb Temperature	Total Air Volume		Outdoor Air Temperature Entering Outdoor Coil																							
			65°F (18°C)						75°F (24°C)						85°F (29°C)						95°F (35°C)					
			Total Cooling Capacity	Comp Motor kW Input	Sensible To Total Ratio (S/T) Dry Bulb			Total Cooling Capacity	Comp Motor kW Input	Sensible To Total Ratio (S/T) Dry Bulb			Total Cooling Capacity	Comp Motor kW Input	Sensible To Total Ratio (S/T) Dry Bulb			Total Cooling Capacity	Comp Motor kW Input	Sensible To Total Ratio (S/T) Dry Bulb						
					75°F 24°C	80°F 27°C	85°F 29°C			75°F 24°C	80°F 27°C	85°F 29°C			75°F 24°C	80°F 27°C	85°F 29°C			75°F 24°C	80°F 27°C	85°F 29°C				
cfm	L/s	kBtuh	kW	kBtuh	kW	kBtuh	kW	kBtuh	kW	kBtuh	kW	kBtuh	kW	kBtuh	kW	kBtuh	kW	kBtuh	kW	kBtuh	kW					
63°F (17°C)	5600	2645	104.0	30.5	5.70	.64	.79	.94	100.8	29.5	6.34	.65	.81	.96	97.2	28.5	7.06	.66	.82	.98	93.6	27.4	7.88	.67	.84	.99
	7000	3305	108.0	31.7	5.80	.69	.87	1.00	104.4	30.6	6.44	.70	.89	1.00	100.8	29.5	7.14	.72	.91	1.00	97.0	28.4	7.96	.74	.93	1.00
	8400	3965	111.0	32.5	5.86	.75	.95	1.00	107.6	31.5	6.50	.76	.96	1.00	104.0	30.5	7.22	.78	.98	1.00	100.2	29.4	8.06	.80	.99	1.00
67°F (19°C)	5600	2645	110.4	32.4	5.86	.50	.62	.75	107.0	31.4	6.48	.51	.63	.77	103.2	30.2	7.20	.51	.63	.78	99.2	29.1	8.04	.52	.65	.80
	7000	3305	113.8	33.4	5.92	.53	.66	.84	110.2	32.3	6.58	.54	.67	.86	106.2	31.1	7.30	.54	.69	.88	102.0	29.9	8.12	.55	.71	.90
	8400	3965	116.4	34.1	6.00	.56	.72	.91	112.4	32.9	6.62	.56	.74	.93	108.4	31.8	7.34	.57	.76	.95	104.0	30.5	8.18	.58	.78	.97
71°F (22°C)	5600	2645	117.4	34.4	6.02	.38	.49	.60	113.8	33.4	6.66	.38	.49	.60	109.8	32.2	7.38	.39	.50	.61	105.4	30.9	8.22	.39	.51	.63
	7000	3305	120.8	35.4	6.10	.39	.52	.64	116.8	34.2	6.74	.39	.52	.65	112.6	33.0	7.48	.39	.53	.67	108.2	31.7	8.30	.40	.54	.68
	8400	3965	123.2	36.1	6.16	.40	.55	.70	119.0	34.9	6.80	.40	.56	.71	114.8	33.6	7.54	.41	.56	.73	110.2	32.3	8.38	.41	.57	.76

17.5 TON STANDARD EFFICIENCY (R-22) ALL COMPRESSORS OPERATING

LGC210S2

Entering Wet Bulb Temperature	Total Air Volume		Outdoor Air Temperature Entering Outdoor Coil																							
			85°F (29°C)						95°F (35°C)						105°F (41°C)						115°F (46°C)					
			Total Cooling Capacity	Comp Motor kW Input	Sensible To Total Ratio (S/T) Dry Bulb			Total Cooling Capacity	Comp Motor kW Input	Sensible To Total Ratio (S/T) Dry Bulb			Total Cooling Capacity	Comp Motor kW Input	Sensible To Total Ratio (S/T) Dry Bulb			Total Cooling Capacity	Comp Motor kW Input	Sensible To Total Ratio (S/T) Dry Bulb						
					75°F 24°C	80°F 27°C	85°F 29°C			75°F 24°C	80°F 27°C	85°F 29°C			75°F 24°C	80°F 27°C	85°F 29°C			75°F 24°C	80°F 27°C	85°F 29°C				
cfm	L/s	kBtuh	kW	kBtuh	kW	kBtuh	kW	kBtuh	kW	kBtuh	kW	kBtuh	kW	kBtuh	kW	kBtuh	kW	kBtuh	kW	kBtuh	kW					
63°F (17°C)	5600	2645	202.0	59.2	14.24	.69	.84	.98	194.4	57.0	15.88	.70	.86	.99	186.2	54.6	17.76	.72	.88	1.00	177.4	52.0	19.92	.73	.91	1.00
	7000	3305	209.4	61.4	14.40	.74	.92	1.00	201.4	59.0	16.06	.76	.94	1.00	193.2	56.6	17.96	.78	.96	1.00	184.4	54.0	20.12	.80	.99	1.00
	8400	3965	215.8	63.2	14.56	.80	.98	1.00	208.0	61.0	16.26	.82	1.00	1.00	199.8	58.6	18.16	.85	1.00	1.00	191.2	56.0	20.34	.87	1.00	1.00
67°F (19°C)	5600	2645	214.4	62.8	14.52	.54	.67	.80	206.0	60.4	16.22	.55	.68	.82	197.0	57.7	18.10	.55	.69	.84	187.6	55.0	20.24	.56	.71	.87
	7000	3305	220.6	64.7	14.72	.57	.72	.89	212.0	62.1	16.38	.58	.73	.91	202.8	59.4	18.28	.59	.75	.93	192.6	56.4	20.46	.60	.78	.96
	8400	3965	225.2	66.0	14.82	.60	.78	.96	216.2	63.4	16.50	.61	.80	.98	206.6	60.5	18.40	.62	.82	.99	196.6	57.6	20.54	.64	.85	1.00
71°F (22°C)	5600	2645	228.0	66.8	14.88	.40	.52	.64	219.2	64.2	16.58	.41	.53	.66	209.8	61.5	18.48	.41	.54	.67	199.6	58.5	20.66	.41	.55	.69
	7000	3305	234.0	68.6	15.08	.42	.56	.70	224.8	65.9	16.74	.42	.57	.71	215.2	63.1	18.64	.42	.58	.73	204.6	60.0	20.82	.43	.59</	

COOLING RATINGS

NOTE - For Temperatures and Capacities not shown in tables, see bulletin — Cooling Unit Rating Table Correction Factor Data in Miscellaneous Engineering Data section.

17.5 TON HIGH EFFICIENCY (R-22) TWO COMPRESSORS OPERATING

LGC210H2

Entering Wet Bulb Temperature	Total Air Volume		Outdoor Air Temperature Entering Outdoor Coil																							
			65°F (18°C)						75°F (24°C)						85°F (29°C)						95°F (35°C)					
			Total Cooling Capacity		Comp Motor kW Input	Sensible To Total Ratio (S/T) Dry Bulb			Total Cooling Capacity		Comp Motor kW Input	Sensible To Total Ratio (S/T) Dry Bulb			Total Cooling Capacity		Comp Motor kW Input	Sensible To Total Ratio (S/T) Dry Bulb			Total Cooling Capacity		Comp Motor kW Input	Sensible To Total Ratio (S/T) Dry Bulb		
			kBtuh	kW		75°F 24°C	80°F 27°C	85°F 29°C	kBtuh	kW		75°F 24°C	80°F 27°C	85°F 29°C	kBtuh	kW		75°F 24°C	80°F 27°C	85°F 29°C	kBtuh	kW		75°F 24°C	80°F 27°C	85°F 29°C
63°F (17°C)	5600	2645	109.2	32.0	4.94	.65	.80	.95	106.2	31.1	5.58	.66	.81	.97	102.6	30.1	6.28	.67	.83	.98	98.8	29.0	7.08	.68	.85	1.00
	7000	3305	114.0	33.4	4.98	.70	.89	1.00	110.6	32.4	5.60	.72	.91	1.00	106.8	31.3	6.32	.73	.93	1.00	102.8	30.1	7.12	.75	.95	1.00
	8400	3965	117.6	34.5	5.00	.76	.97	1.00	114.2	33.5	5.64	.78	.98	1.00	110.6	32.4	6.34	.80	1.00	1.00	107.0	31.4	7.14	.82	1.00	1.00
67°F (19°C)	5600	2645	116.6	34.2	5.00	.51	.63	.76	113.2	33.2	5.62	.51	.63	.77	109.4	32.1	6.34	.52	.64	.79	105.2	30.8	7.14	.53	.65	.81
	7000	3305	120.8	35.4	5.02	.54	.67	.85	117.0	34.3	5.66	.55	.69	.86	113.0	33.1	6.38	.55	.70	.89	108.6	31.8	7.18	.56	.72	.91
	8400	3965	123.8	36.3	5.06	.57	.74	.93	119.8	35.1	5.68	.58	.75	.95	115.6	33.9	6.40	.58	.77	.97	111.0	32.5	7.20	.60	.79	.99
71°F (22°C)	5600	2645	124.8	36.6	5.06	.39	.49	.60	121.0	35.8	5.70	.39	.50	.61	116.8	34.2	6.40	.39	.50	.62	112.4	32.9	7.20	.39	.51	.63
	7000	3305	129.0	37.8	5.10	.40	.52	.65	124.8	36.6	5.72	.40	.53	.66	120.4	35.3	6.44	.40	.54	.67	115.6	33.9	7.24	.40	.55	.69
	8400	3965	131.8	38.6	5.12	.41	.56	.71	127.4	37.3	5.76	.41	.56	.72	122.8	36.0	6.46	.41	.57	.74	117.8	34.5	7.26	.42	.59	.77

17.5 TON HIGH EFFICIENCY (R-22) ALL COMPRESSORS OPERATING

LGC210H2

Entering Wet Bulb Temperature	Total Air Volume		Outdoor Air Temperature Entering Outdoor Coil																							
			85°F (29°C)						95°F (35°C)						105°F (41°C)						115°F (46°C)					
			Total Cooling Capacity		Comp Motor kW Input	Sensible To Total Ratio (S/T) Dry Bulb			Total Cooling Capacity		Comp Motor kW Input	Sensible To Total Ratio (S/T) Dry Bulb			Total Cooling Capacity		Comp Motor kW Input	Sensible To Total Ratio (S/T) Dry Bulb			Total Cooling Capacity		Comp Motor kW Input	Sensible To Total Ratio (S/T) Dry Bulb		
			kBtuh	kW		75°F 24°C	80°F 27°C	85°F 29°C	kBtuh	kW		75°F 24°C	80°F 27°C	85°F 29°C	kBtuh	kW		75°F 24°C	80°F 27°C	85°F 29°C	kBtuh	kW		75°F 24°C	80°F 27°C	85°F 29°C
63°F (17°C)	5600	2645	207.7	60.9	12.74	.70	.85	.98	200.3	58.7	14.36	.71	.87	1.00	192.0	56.3	16.20	.73	.89	1.00	183.1	53.7	18.30	.74	.91	1.00
	7000	3305	216.4	63.4	12.82	.76	.93	1.00	208.4	61.1	14.44	.78	.95	1.00	199.9	58.6	16.30	.79	.97	1.00	191.2	56.0	18.36	.82	.99	1.00
	8400	3965	223.8	65.6	12.86	.82	.99	1.00	216.4	63.4	14.50	.84	1.00	1.00	208.4	61.1	16.34	.86	1.00	1.00	199.6	58.5	18.44	.89	1.00	1.00
67°F (19°C)	5600	2645	221.4	64.9	12.84	.55	.68	.81	213.2	62.5	14.48	.56	.69	.83	204.3	59.9	16.32	.56	.70	.85	194.7	57.1	18.42	.57	.72	.87
	7000	3305	228.9	67.1	12.92	.58	.74	.90	220.1	64.5	14.56	.59	.75	.92	210.8	61.8	16.38	.60	.77	.94	200.8	58.8	18.48	.61	.79	.97
	8400	3965	234.2	68.6	12.96	.62	.80	.97	225.2	66.0	14.60	.63	.81	.99	215.3	63.1	16.42	.64	.84	1.00	205.2	60.1	18.52	.65	.86	1.00
71°F (22°C)	5600	2645	236.6	69.3	12.98	.41	.53	.65	228.0	66.8	14.60	.41	.54	.66	218.4	64.0	16.46	.42	.55	.68	208.0	61.0	18.56	.42	.56	.69
	7000	3305	244.1	71.5	13.04	.42	.57	.71	234.5	68.7	14.68	.43	.58	.73	224.4	65.8	16.50	.43	.59	.74	213.7	62.6	18.60	.44	.60	.76
	8400	3965	249.0	73.0	13.08	.44	.60	.77	239.0	70.0	14.72	.44	.62	.79	228.6	67.0	16.54	.45	.63	.81	217.6	63.8	18.64	.45	.65	.84

17.5 TON HIGH EFFICIENCY (R-410A) TWO COMPRESSORS OPERATING

LGC210H4

Entering Wet Bulb Temperature	Total Air Volume		Outdoor Air Temperature Entering Outdoor Coil																							
			65°F (18°C)						75°F (24°C)						85°F (29°C)						95°F (35°C)					
			Total Cooling Capacity		Comp Motor kW Input	Sensible To Total Ratio (S/T) Dry Bulb			Total Cooling Capacity		Comp Motor kW Input	Sensible To Total Ratio (S/T) Dry Bulb			Total Cooling Capacity		Comp Motor kW Input	Sensible To Total Ratio (S/T) Dry Bulb			Total Cooling Capacity		Comp Motor kW Input	Sensible To Total Ratio (S/T) Dry Bulb		
			kBtuh	kW		75°F 24°C	80°F 27°C	85°F 29°C	kBtuh	kW		75°F 24°C	80°F 27°C	85°F 29°C	kBtuh	kW		75°F 24°C	80°F 27°C	85°F 29°C	kBtuh	kW		75°F 24°C	80°F 27°C	85°F 29°C
63°F (17°C)	5600	2645	110.3	32.3	4.81	.66	.80	.96	106.3	31.2	5.48	.67	.82	.97	102.1	29.9	6.22	.68	.84	.99	97.5	28.6	7.07	.69	.87	1.00
	7000	3305	114.7	33.6	4.84	.71	.89	1.00	110.5	32.4	5.51	.72	.91	1.00	106.2	31.1	6.26	.74	.94	1.00	101.5	29.7	7.11	.76	.96	1.00
	8400	3965	118.4	34.7	4.87	.77	.97	1.00	114.3	33.5	5.54	.79	.99	1.00	110.1	32.3	6.28	.81	1.00	1.00	105.8	31.0	7.14	.84	1.00	1.00
67°F (19°C)	5600	2645	117.2	34.3	4.86	.52	.64	.76	113.0	33.1	5.53	.52	.64	.78	108.5	31.8	6.27	.53	.65	.80	103.7	30.4	7.13	.54	.67	.83
	7000	3305	121.3	35.5	4.89	.55	.68	.85	116.8	34.2	5.57	.55	.70	.88	112.1	32.9	6.31	.56	.71	.90	107.0	31.4	7.15	.57	.74	.93
	8400	3965	124.1	36.4	4.92	.58	.75	.94	119.5	35.0	5.59	.59	.76	.96	114.6	33.6	6.33	.60	.79	.98	109.4	32.1	7.18	.61	.81	1.00
71°F (22°C)	5600	2645	125.1	36.7	4.92	.39	.50	.61	120.7	35.4	5.59	.39	.51	.62	115.9	34.0	6.34	.39	.51	.63	110.8	32.5	7.20	.40	.52	.64
	7000	3305	129.1	37.8	4.96	.40	.53	.66	124.3	36.4	5.63	.40	.54	.67	119.3	35.0	6.38	.41	.55	.69	113.9	33.4	7.23	.41	.56	.71
	8400	3965	131.8	38.6	4.98	.41	.56	.72	126.9	37.2	5.65	.42	.57	.74	121.5	35.6	6.40	.42	.59	.76	116.0	34.0	7.25	.42	.60	.79

17.5 TON HIGH EFFICIENCY (R-410A) ALL COMPRESSORS OPERATING

LGC210H4

Entering Wet Bulb Temperature	Total Air Volume		Outdoor Air Temperature Entering Outdoor Coil																							
			85°F (29°C)						95°F (35°C)						105°F (41°C)						115°F (46°C)					
			Total Cooling Capacity		Comp Motor kW Input	Sensible To Total Ratio (S/T) Dry Bulb			Total Cooling Capacity		Comp Motor kW Input	Sensible To Total Ratio (S/T) Dry Bulb			Total Cooling Capacity		Comp Motor kW Input	Sensible To Total Ratio (S/T) Dry Bulb			Total Cooling Capacity		Comp Motor kW Input	Sensible To Total Ratio (S/T) Dry Bulb		
			kBtuh	kW		75°F 24°C	80°F 27°C	85°F 29°C	kBtuh	kW		75°F 24°C	80°F 27°C	85°F 29°C	kBtuh	kW		75°F 24°C	80°F 27°C	85°F 29°C	kBtuh	kW		75°F 24°C	80°F 27°C	85°F 29°C
63°F (17°C)	5600	2645	204.9	60.1	12.24	.74	.88	1.00	195.8	57.4	13.92	.75	.90	1.00	186.2	54.6	15.85	.77	.92	1.00	175.9	51.6	18.11	.79	.95	1.00
	7000	3305	213.2	62.5	12.32	.80	.95	1.00	203.8	59.7	13.98	.82	.97	1.00	194.3	56.9	15.91	.84	.99	1.00	184.8	54.2	18.16	.86	1.00	1.00
	8400	3965	221.1	64.8	12.36	.85	1.00	1.00	212.3	62.2	14.04	.88	1.00	1.00	203.0	59.5	15.99	.90	1.00	1.00	193.3	56.7	18.23	.93	1.00	1.00
67°F (19°C)	5600	2645	217.9	63.9	12.35	.57	.71	.85	208.1	61.0	14.03	.58	.73	.86	197.8	58.0	15.95	.59	.74	.89	187.0	54.8	18.20	.60	.76	.91
	7000	3305	224.9	65.9	12.42	.61	.77	.92	214.7	62.9	14.07	.62	.79	.95	204.1	59.8	16.00	.64	.81	.97	192.7	56.5	18.26	.65	.84	.99
	8400	3965	230.1	67.4	12.46	.65	.83	.99	219.4	64.3	14.13	.66	.86	1.00	208.6	61.1	16.07	.68	.88	1.00	197.2	57.8	18.32	.70	.91	1.00
71°F (22°C)	5600	2645	232.6	68.2	12.48	.43	.56	.69	222.3	65.1	14.15	.43	.57	.70	211.5	62.0	16.08	.43	.58	.72	200.0	58.6	18.34	.44	.59	.74
	7000	3305	239.4	70.2	12.55	.44	.60	.75	228.6	67.0	14.22	.45	.61	.77	217.2	63.7	16.15	.45	.62	.79	205.2	60.1	18.41	.46	.64	.81
	8400	3965	244.0	71.5	12.59	.46	.64	.81	232.8	68.2	14.27	.46	.65	.83	221.2	64.8	16.19	.47	.67	.86	209.1	61.3	18.46	.48	.69	.88

COOLING RATINGS

NOTE - For Temperatures and Capacities not shown in tables, see bulletin — Cooling Unit Rating Table Correction Factor Data in Miscellaneous Engineering Data section.

20 TON STANDARD EFFICIENCY (R-22) TWO COMPRESSORS OPERATING

LGC240S2

Entering Wet Bulb Temperature	Total Air Volume		Outdoor Air Temperature Entering Outdoor Coil																							
			65°F (18°C)						75°F (24°C)						85°F (29°C)						95°F (35°C)					
			Total Cooling Capacity		Comp Motor kW Input	Sensible To Total Ratio (S/T) Dry Bulb			Total Cooling Capacity		Comp Motor kW Input	Sensible To Total Ratio (S/T) Dry Bulb			Total Cooling Capacity		Comp Motor kW Input	Sensible To Total Ratio (S/T) Dry Bulb			Total Cooling Capacity		Comp Motor kW Input	Sensible To Total Ratio (S/T) Dry Bulb		
			kBtuh	kW		75°F 24°C	80°F 27°C	85°F 29°C	kBtuh	kW		75°F 24°C	80°F 27°C	85°F 29°C	kBtuh	kW		75°F 24°C	80°F 27°C	85°F 29°C	kBtuh	kW		75°F 24°C	80°F 27°C	85°F 29°C
63°F (17°C)	6400	3020	118.8	34.8	6.72	.60	.76	.92	115.8	33.9	7.38	.61	.77	.94	112.0	32.8	8.14	.62	.79	.96	108.0	31.7	9.02	.62	.81	.98
	8000	3775	123.0	36.0	6.80	.65	.85	1.00	120.0	35.2	7.46	.66	.86	1.00	116.2	34.1	8.24	.67	.89	1.00	112.2	32.9	9.12	.69	.91	1.00
	9600	4530	126.4	37.0	6.86	.71	.93	1.00	123.4	36.2	7.54	.72	.94	1.00	119.6	35.1	8.30	.74	.96	1.00	115.6	33.9	9.18	.76	.98	1.00
67°F (19°C)	6400	3020	126.0	36.9	6.86	.48	.58	.72	122.8	36.0	7.52	.48	.59	.73	119.0	34.9	8.28	.48	.59	.74	114.6	33.6	9.16	.49	.60	.76
	8000	3775	129.8	38.0	6.92	.50	.62	.81	126.4	37.0	7.58	.50	.63	.82	122.6	35.9	8.36	.51	.64	.84	118.0	34.6	9.26	.51	.66	.87
	9600	4530	132.4	38.8	6.98	.52	.68	.89	129.0	37.8	7.64	.53	.70	.91	125.0	36.6	8.42	.54	.72	.93	120.4	35.3	9.30	.54	.74	.95
71°F (22°C)	6400	3020	133.8	39.2	7.02	.36	.46	.56	130.6	38.3	7.66	.36	.46	.56	126.6	37.1	8.44	.36	.47	.57	122.2	35.8	9.32	.36	.47	.58
	8000	3775	137.4	40.3	7.08	.37	.49	.61	134.2	39.3	7.74	.37	.49	.61	130.0	38.1	8.52	.37	.50	.62	125.4	36.8	9.40	.37	.50	.63
	9600	4530	140.0	41.0	7.14	.38	.51	.66	136.6	40.0	7.80	.38	.52	.67	132.4	38.8	8.56	.38	.53	.69	127.6	37.4	9.46	.39	.53	.71

20 TON STANDARD EFFICIENCY (R-22) ALL COMPRESSORS OPERATING

LGC240S2

Entering Wet Bulb Temperature	Total Air Volume		Outdoor Air Temperature Entering Outdoor Coil																							
			85°F (29°C)						95°F (35°C)						105°F (41°C)						115°F (46°C)					
			Total Cooling Capacity		Comp Motor kW Input	Sensible To Total Ratio (S/T) Dry Bulb			Total Cooling Capacity		Comp Motor kW Input	Sensible To Total Ratio (S/T) Dry Bulb			Total Cooling Capacity		Comp Motor kW Input	Sensible To Total Ratio (S/T) Dry Bulb			Total Cooling Capacity		Comp Motor kW Input	Sensible To Total Ratio (S/T) Dry Bulb		
			kBtuh	kW		75°F 24°C	80°F 27°C	85°F 29°C	kBtuh	kW		75°F 24°C	80°F 27°C	85°F 29°C	kBtuh	kW		75°F 24°C	80°F 27°C	85°F 29°C	kBtuh	kW		75°F 24°C	80°F 27°C	85°F 29°C
63°F (17°C)	6400	3020	230.6	67.6	16.66	.69	.85	.99	222.4	65.2	18.46	.70	.86	1.00	213.8	62.7	20.54	.71	.88	1.00	205.4	60.2	22.84	.73	.91	1.00
	8000	3775	239.2	70.1	16.86	.74	.93	1.00	231.0	67.7	18.66	.76	.95	1.00	222.0	65.1	20.70	.78	.97	1.00	213.4	62.5	23.02	.80	.99	1.00
	9600	4530	246.2	72.2	16.98	.80	1.00	1.00	238.0	69.8	18.80	.82	1.00	1.00	229.4	67.2	20.88	.84	1.00	1.00	220.8	64.7	23.24	.87	1.00	1.00
67°F (19°C)	6400	3020	245.0	71.8	16.94	.54	.67	.81	236.0	69.2	18.76	.55	.68	.82	227.0	66.5	20.82	.55	.69	.84	217.6	63.8	23.18	.56	.70	.87
	8000	3775	252.2	73.9	17.10	.57	.72	.89	243.0	71.2	18.94	.58	.73	.91	233.4	68.4	21.00	.59	.75	.94	223.8	65.6	23.34	.60	.77	.96
	9600	4530	257.4	75.4	17.24	.60	.78	.97	248.0	72.7	19.04	.61	.80	.99	238.4	69.9	21.12	.62	.82	1.00	228.4	66.9	23.46	.63	.84	1.00
71°F (22°C)	6400	3020	260.6	76.4	17.28	.41	.52	.64	251.6	73.7	19.08	.41	.53	.65	241.8	70.9	21.18	.41	.54	.67	232.0	68.0	23.58	.41	.55	.68
	8000	3775	267.6	78.4	17.44	.42	.56	.70	258.2	75.7	19.24	.42	.57	.71	248.0	72.7	21.36	.42	.58	.73	237.8	69.7	23.72	.43	.58	.74
	9600	4530	272.6	79.9	17.52	.43	.59	.75	262.8	77.0	19.36	.43	.60	.77	252.4	74.0	21.46	.44	.61	.79	241.8	70.9	23.84	.44	.62	.82

20 TON HIGH EFFICIENCY (R-22) TWO COMPRESSORS OPERATING

LGA240H2

Entering Wet Bulb Temperature	Total Air Volume		Outdoor Air Temperature Entering Outdoor Coil																							
			65°F (18°C)						75°F (24°C)						85°F (29°C)						95°F (35°C)					
			Total Cooling Capacity		Comp Motor kW Input	Sensible To Total Ratio (S/T) Dry Bulb			Total Cooling Capacity		Comp Motor kW Input	Sensible To Total Ratio (S/T) Dry Bulb			Total Cooling Capacity		Comp Motor kW Input	Sensible To Total Ratio (S/T) Dry Bulb			Total Cooling Capacity		Comp Motor kW Input	Sensible To Total Ratio (S/T) Dry Bulb		
			kBtuh	kW		75°F 24°C	80°F 27°C	85°F 29°C	kBtuh	kW		75°F 24°C	80°F 27°C	85°F 29°C	kBtuh	kW		75°F 24°C	80°F 27°C	85°F 29°C	kBtuh	kW		75°F 24°C	80°F 27°C	85°F 29°C
63°F (17°C)	6400	3020	126.6	37.1	6.26	.63	.78	.94	122.8	36.0	7.04	.64	.80	.95	118.8	34.8	7.94	.65	.81	.97	114.8	33.6	8.98	.66	.83	.99
	8000	3775	131.6	38.6	6.32	.68	.87	1.00	127.8	37.5	7.08	.69	.89	1.00	123.6	36.2	8.00	.71	.91	1.00	119.2	34.9	9.04	.73	.93	1.00
	9600	4530	135.8	39.8	6.36	.74	.95	1.00	131.8	38.6	7.14	.76	.97	1.00	127.6	37.4	8.04	.78	.98	1.00	123.4	36.2	9.10	.80	1.00	1.00
67°F (19°C)	6400	3020	134.6	39.4	6.34	.50	.61	.74	130.6	38.3	7.12	.50	.62	.75	126.4	37.0	8.02	.51	.62	.77	121.8	35.7	9.08	.51	.63	.79
	8000	3775	139.2	40.8	6.40	.52	.65	.83	134.8	39.5	7.18	.53	.67	.85	130.4	38.2	8.08	.54	.68	.87	125.6	36.8	9.13	.54	.70	.89
	9600	4530	142.4	41.7	6.42	.55	.72	.91	138.0	40.4	7.20	.56	.73	.93	133.4	39.1	8.12	.57	.75	.95	128.4	37.6	9.18	.58	.77	.97
71°F (22°C)	6400	3020	143.6	42.1	6.44	.38	.48	.59	139.4	40.9	7.22	.38	.49	.59	134.8	39.5	8.14	.38	.49	.60	129.8	38.0	9.20	.38	.50	.61
	8000	3775	148.0	43.4	6.48	.39	.51	.63	143.4	42.0	7.28	.39	.52	.64	138.6	40.6	8.18	.39	.52	.66	133.6	39.2	9.24	.39	.53	.67
	9600	4530	151.2	44.3	6.52	.40	.54	.69	146.4	42.9	7.30	.40	.55	.70	141.4	41.4	8.24	.40	.56	.72	136.0	39.9	9.28	.41	.57	.74

20 TON HIGH EFFICIENCY (R-22) ALL COMPRESSORS OPERATING

LGA240H2

Entering Wet Bulb Temperature	Total Air Volume		Outdoor Air Temperature Entering Outdoor Coil																							
			85°F (29°C)						95°F (35°C)						105°F (41°C)						115°F (46°C)					
			Total Cooling Capacity		Comp Motor kW Input	Sensible To Total Ratio (S/T) Dry Bulb			Total Cooling Capacity		Comp Motor kW Input	Sensible To Total Ratio (S/T) Dry Bulb			Total Cooling Capacity		Comp Motor kW Input	Sensible To Total Ratio (S/T) Dry Bulb			Total Cooling Capacity		Comp Motor kW Input	Sensible To Total Ratio (S/T) Dry Bulb		
			kBtuh	kW		75°F 24°C	80°F 27°C	85°F 29°C	kBtuh	kW		75°F 24°C	80°F 27°C	85°F 29°C	kBtuh	kW		75°F 24°C	80°F 27°C	85°F 29°C	kBtuh	kW		75°F 24°C	80°F 27°C	85°F 29°C
63°F (17°C)	6400	3020	238.4	69.9	15.72	.70	.85	.99	230.2	67.5	17.80	.71	.86	1.00	221.2	64.8	20.16	.72	.88	1.00	211.5	62.0	22.82	.73	.91	1.00
	8000	3775	248.0	72.7	15.84	.75	.93	1.00	239.2	70.1	17.90	.77	.95	1.00	230.0	67.4	20.28	.78	.97	1.00	220.2	64.5	22.96	.81	.99	1.00
	9600	4530	256.0	75.0	15.92	.81	1.00	1.00	247.6	72.6	18.02	.83	1.00	1.00	238.6	69.9	20.40	.85	1.00	1.00	229.4	67.2	23.09	.88	1.00	1.00
67°F (19°C)	6400	3020	253.4	74.3	15.89	.55	.67	.81	244.3	71.6	17.98	.55	.68	.82	234.8	68.8	20.32	.56	.69	.84	224.4	65.8	23.02	.57	.71	.87
	8000	3775	261.6	76.7	16.00	.58	.73	.89	252.0	73.9	18.09	.58	.74	.91	241.9	70.9	20.48	.59	.76	.94	231.0	67.7	23.18	.60	.78	.96
	9600	4530	267.5	78.4	16.08	.61	.79	.97	257.6	75.5	18.18	.62	.81	.99	247.1	72.4	20.56	.63	.83	1.00	236.0	69.2	23.24	.64	.85	1.00
71°F (22°C)	6400	3020	270.3	79.2	16.12	.41	.53	.65	260.5	76.3	18.22	.41	.53	.66	250.4	73.4	20.60	.41	.54	.67	239.5	70.2	23.28	.42	.55	.69
	8000	3775	278.1	81.5	16.20	.42	.56	.70	268.0	78.5	18.30	.42	.57	.72	257.2	75.4	20.72	.43	.58	.73	245.7	72.0	23.40	.43	.59	.75
	9600	4530	283.6	83.1	16.32	.43	.60	.76	272.9	80.0	18.39	.44	.61	.78	261.7	76.7	20.79	.44	.62	.81	249.9	73.2	23.48	.45	.64	.83

COOLING RATINGS

NOTE - For Temperatures and Capacities not shown in tables, see bulletin — Cooling Unit Rating Table Correction Factor Data in Miscellaneous Engineering Data section.

20 TON HIGH EFFICIENCY (R-410A) TWO COMPRESSORS OPERATING

LGA240H4

Entering Wet Bulb Temperature	Total Air Volume		Outdoor Air Temperature Entering Outdoor Coil																							
			65°F (18°C)						75°F (24°C)						85°F (29°C)						95°F (35°C)					
			Total Cooling Capacity		Comp Motor kW Input	Sensible To Total Ratio (S/T) Dry Bulb			Total Cooling Capacity		Comp Motor kW Input	Sensible To Total Ratio (S/T) Dry Bulb			Total Cooling Capacity		Comp Motor kW Input	Sensible To Total Ratio (S/T) Dry Bulb			Total Cooling Capacity		Comp Motor kW Input	Sensible To Total Ratio (S/T) Dry Bulb		
						75°F 24°C	80°F 27°C	85°F 29°C				75°F 24°C	80°F 27°C	85°F 29°C				75°F 24°C	80°F 27°C	85°F 29°C				75°F 24°C	80°F 27°C	85°F 29°C
63°F (17°C)	6400	3020	124.8	36.6	5.52	.62	.77	.93	120.4	35.3	6.28	.63	.79	.95	115.6	33.9	7.15	.64	.81	.97	110.5	32.4	8.14	.65	.84	.98
	8000	3775	129.8	38.0	5.57	.67	.86	.99	125.1	36.7	6.34	.69	.89	1.00	120.1	35.2	7.21	.70	.91	1.00	114.8	33.6	8.21	.73	.94	1.00
	9600	4530	133.9	39.2	5.61	.74	.94	1.00	129.1	37.8	6.40	.76	.96	1.00	124.2	36.4	7.26	.78	.98	1.00	119.0	34.9	8.26	.80	.99	1.00
67°F (19°C)	6400	3020	132.5	38.8	5.60	.49	.60	.73	127.6	37.4	6.38	.50	.61	.75	122.5	35.9	7.25	.50	.62	.77	117.0	34.3	8.23	.51	.63	.79
	8000	3775	136.9	40.1	5.65	.52	.65	.82	131.8	38.6	6.43	.52	.66	.85	126.4	37.0	7.30	.53	.68	.87	120.6	35.3	8.31	.54	.70	.90
	9600	4530	140.2	41.1	5.69	.55	.71	.91	134.8	39.5	6.48	.55	.73	.93	129.2	37.9	7.35	.56	.75	.96	123.1	36.1	8.34	.58	.78	.98
71°F (22°C)	6400	3020	141.1	41.4	5.70	.37	.48	.58	135.8	39.8	6.48	.38	.48	.59	130.4	38.2	7.37	.38	.49	.60	124.4	36.5	8.36	.38	.50	.61
	8000	3775	145.5	42.6	5.76	.38	.50	.63	139.9	41.0	6.55	.38	.51	.64	134.0	39.3	7.43	.39	.52	.65	127.8	37.5	8.42	.39	.53	.67
	9600	4530	148.4	43.5	5.80	.39	.53	.68	142.5	41.8	6.59	.40	.54	.70	136.4	40.0	7.47	.40	.56	.73	130.1	38.1	8.46	.40	.57	.75

20 TON HIGH EFFICIENCY (R-410A) ALL COMPRESSORS OPERATING

LGA240H4

Entering Wet Bulb Temperature	Total Air Volume		Outdoor Air Temperature Entering Outdoor Coil																							
			85°F (29°C)						95°F (35°C)						105°F (41°C)						115°F (46°C)					
			Total Cooling Capacity		Comp Motor kW Input	Sensible To Total Ratio (S/T) Dry Bulb			Total Cooling Capacity		Comp Motor kW Input	Sensible To Total Ratio (S/T) Dry Bulb			Total Cooling Capacity		Comp Motor kW Input	Sensible To Total Ratio (S/T) Dry Bulb			Total Cooling Capacity		Comp Motor kW Input	Sensible To Total Ratio (S/T) Dry Bulb		
						75°F 24°C	80°F 27°C	85°F 29°C				75°F 24°C	80°F 27°C	85°F 29°C				75°F 24°C	80°F 27°C	85°F 29°C				75°F 24°C	80°F 27°C	85°F 29°C
63°F (17°C)	6400	3020	232.6	68.2	14.27	.72	.86	.99	222.3	65.1	16.25	.73	.89	.99	211.2	61.9	18.54	.75	.91	1.00	199.2	58.4	21.21	.77	.94	1.00
	8000	3775	241.6	70.8	14.41	.77	.95	1.00	231.0	67.7	16.38	.79	.97	1.00	220.0	64.5	18.67	.82	.99	1.00	208.3	61.0	21.34	.85	.99	1.00
	9600	4530	250.0	73.3	14.53	.84	.99	1.00	239.7	70.2	16.50	.86	1.00	1.00	228.6	67.0	18.80	.89	1.00	1.00	216.5	63.4	21.48	.92	1.00	1.00
67°F (19°C)	6400	3020	246.3	72.2	14.46	.56	.69	.83	235.2	68.9	16.44	.57	.71	.85	223.1	65.4	18.74	.58	.73	.88	210.0	61.5	21.41	.59	.75	.91
	8000	3775	253.8	74.4	14.60	.59	.75	.91	242.0	70.9	16.59	.61	.77	.94	229.3	67.2	18.86	.62	.80	.96	215.8	63.2	21.51	.63	.82	.99
	9600	4530	259.2	76.0	14.67	.63	.82	.98	247.0	72.4	16.66	.64	.84	.99	234.1	68.6	18.94	.66	.87	1.00	220.3	64.6	21.59	.68	.90	1.00
71°F (22°C)	6400	3020	261.9	76.8	14.70	.42	.54	.67	249.8	73.2	16.69	.42	.55	.68	236.9	69.4	19.01	.42	.56	.70	223.1	65.4	21.64	.43	.58	.72
	8000	3775	268.8	78.8	14.85	.43	.58	.73	256.3	75.1	16.81	.43	.59	.75	242.8	71.2	19.11	.44	.61	.77	228.2	66.9	21.75	.45	.63	.80
	9600	4530	273.4	80.1	14.91	.44	.62	.80	260.7	76.4	16.90	.45	.64	.82	246.8	72.3	19.18	.46	.65	.85	231.7	67.9	21.83	.47	.68	.88

25 TON STANDARD EFFICIENCY (R-22) TWO COMPRESSORS OPERATING

LGC300S2

Entering Wet Bulb Temperature	Total Air Volume		Outdoor Air Temperature Entering Outdoor Coil																							
			65°F (18°C)						75°F (24°C)						85°F (29°C)						95°F (35°C)					
			Total Cooling Capacity		Comp Motor kW Input	Sensible To Total Ratio (S/T) Dry Bulb			Total Cooling Capacity		Comp Motor kW Input	Sensible To Total Ratio (S/T) Dry Bulb			Total Cooling Capacity		Comp Motor kW Input	Sensible To Total Ratio (S/T) Dry Bulb			Total Cooling Capacity		Comp Motor kW Input	Sensible To Total Ratio (S/T) Dry Bulb		
						75°F 24°C	80°F 27°C	85°F 29°C				75°F 24°C	80°F 27°C	85°F 29°C				75°F 24°C	80°F 27°C	85°F 29°C				75°F 24°C	80°F 27°C	85°F 29°C
63°F (17°C)	8000	3775	149.0	43.7	8.34	.61	.77	.94	144.6	42.4	9.28	.61	.78	.95	140.0	41.0	10.38	.62	.80	.97	135.0	39.6	11.62	.63	.82	.99
	10000	4720	154.6	45.3	8.46	.66	.86	1.00	150.0	44.0	9.42	.67	.88	1.00	145.2	42.6	10.50	.69	.90	1.00	140.0	41.0	11.74	.71	.93	1.00
	12000	5665	159.2	46.7	8.56	.73	.95	1.00	154.4	45.3	9.52	.74	.96	1.00	149.6	43.8	10.62	.76	.98	1.00	140.0	41.0	11.88	.78	1.00	1.00
67°F (19°C)	8000	3775	158.0	46.3	8.52	.48	.59	.72	153.2	44.9	9.48	.48	.59	.74	148.0	43.4	10.58	.49	.60	.75	142.8	41.9	11.82	.49	.61	.78
	10000	4720	162.8	47.7	8.64	.50	.63	.82	157.8	46.2	9.60	.51	.64	.84	152.4	44.7	10.70	.51	.66	.86	146.8	43.0	11.94	.52	.68	.89
	12000	5665	166.2	48.7	8.74	.53	.70	.91	161.0	47.2	9.70	.54	.71	.93	155.6	45.6	10.78	.55	.73	.95	149.8	43.9	12.04	.55	.76	.97
71°F (22°C)	8000	3775	167.8	49.2	8.76	.36	.46	.56	162.6	47.7	9.74	.36	.47	.57	157.4	46.1	10.82	.36	.47	.58	151.6	44.4	12.08	.37	.48	.59
	10000	4720	172.4	50.5	8.88	.37	.49	.61	167.2	49.0	9.84	.37	.50	.62	161.4	47.3	10.94	.37	.50	.63	155.4	45.5	12.20	.38	.51	.65
	12000	5665	175.6	51.5	8.96	.38	.52	.67	170.0	49.8	9.94	.38	.53	.69	164.2	48.1	11.02	.39	.54	.71	158.2	46.4	12.28	.39	.55	.73

25 TON STANDARD EFFICIENCY (R-22) ALL COMPRESSORS OPERATING

LGC300S2

Entering Wet Bulb Temperature	Total Air Volume		Outdoor Air Temperature Entering Outdoor Coil																							
			85°F (29°C)						95°F (35°C)						105°F (41°C)						115°F (46°C)					
			Total Cooling Capacity		Comp Motor kW Input	Sensible To Total Ratio (S/T) Dry Bulb			Total Cooling Capacity		Comp Motor kW Input	Sensible To Total Ratio (S/T) Dry Bulb			Total Cooling Capacity		Comp Motor kW Input	Sensible To Total Ratio (S/T) Dry Bulb			Total Cooling Capacity		Comp Motor kW Input	Sensible To Total Ratio (S/T) Dry Bulb		
						75°F 24°C	80°F 27°C	85°F 29°C				75°F 24°C	80°F 27°C	85°F 29°C				75°F 24°C	80°F 27°C	85°F 29°C				75°F 24°C	80°F 27°C	85°F 29°C
63°F (17°C)	8000	3775	291.5	85.4	20.90	.70	.86	1.00	281.1	82.4	23.41	.71	.88	1.00	270.1	79.2	26.23	.72	.90	1.00	258.4	75.7	29.44	.74	.92	1.00
	10000	4720	302.4	88.6	21.15	.76	.95	1.00	291.7	85.5	23.65	.77	.97	1.00	280.5	82.2	26.51	.79	.99	1.00	268.5	78.7	29.74	.78	1.00	1.00
	12000	5665	311.6	91.3	21.38	.82	1.00	1.00	301.3	88.3	23.92	.84	1.00	1.00	290.1	85.0	26.79	.86	1.00	1.00	278.7	81.7	30.05	.89	1.00	1.00
67°F (19°C)	8000	3775	308.4	90.4	21.30	.55	.68	.82	297.4	87.2	23.81	.55	.69	.84	285.5	83.7	26.67	.56	.70	.86	272.7	79.9	29.89	.57	.71	.88
	10000	4720	317.4	93.0	21.55	.58	.73	.91	305.9	89.7	24.05	.59	.75	.93	293.5	86.0	26.91	.60	.77	.96	280.2	82.1	30.17	.61	.79	.98
	12000	5665	324.1	95.0	21.71	.61	.80	.99	312.2	91.5	24.24	.62	.82	1.00	299.4	87.7	27.11	.63	.84	1.00	286.0	83.8	30.37	.65	.87	1.00
71°F (22°C)	8000	3775	327.8	96.1	21.79	.41	.53	.65	315.9	92.6	24.33	.41	.54	.66	303.4	88.9	27.23	.41	.55	.68	290.1	85.0	30.46	.42	.55	.69
	10000	4720	336.3	98.6	22.03	.42	.57	.71	323.9	94.9	24.57	.42	.58	.73	311.0	91.1	27.43	.43	.59	.74	297.0	87.0	30.67	.43	.60	.76
	12000	5665	342.1	100.3	22.20	.43	.60	.77	329.6	96.6	24.73	.44	.61	.79	316.0	92.6	27.63	.44	.63	.82	301.6	88.4	30.87	.45	.64	.84

COOLING RATINGS

NOTE - For Temperatures and Capacities not shown in tables, see bulletin — Cooling Unit Rating Table Correction Factor Data in Miscellaneous Engineering Data section.

25 TON STANDARD EFFICIENCY (R-410A) TWO COMPRESSORS OPERATING

LGC300S4

Entering Wet Bulb Temperature	Total Air Volume		Outdoor Air Temperature Entering Outdoor Coil																							
			65°F (18°C)						75°F (24°C)						85°F (29°C)						95°F (35°C)					
			Total Cooling Capacity		Comp Motor kW Input	Sensible To Total Ratio (S/T) Dry Bulb			Total Cooling Capacity		Comp Motor kW Input	Sensible To Total Ratio (S/T) Dry Bulb			Total Cooling Capacity		Comp Motor kW Input	Sensible To Total Ratio (S/T) Dry Bulb			Total Cooling Capacity		Comp Motor kW Input	Sensible To Total Ratio (S/T) Dry Bulb		
			kBtuh	kW		75°F 24°C	80°F 27°C	85°F 29°C	kBtuh	kW		75°F 24°C	80°F 27°C	85°F 29°C	kBtuh	kW		75°F 24°C	80°F 27°C	85°F 29°C	kBtuh	kW		75°F 24°C	80°F 27°C	85°F 29°C
63°F (17°C)	8000	3775	149.0	43.7	8.34	.61	.77	.94	144.6	42.4	9.28	.61	.78	.95	140.0	41.0	10.38	.62	.80	.97	135.0	39.6	11.62	.63	.82	.99
	10000	4720	154.6	45.3	8.46	.66	.86	1.00	150.0	44.0	9.42	.67	.88	1.00	145.2	42.6	10.50	.69	.90	1.00	140.0	41.0	11.74	.71	.93	1.00
	12000	5665	159.2	46.7	8.56	.73	.95	1.00	154.4	45.3	9.52	.74	.96	1.00	149.6	43.8	10.62	.76	.98	1.00	144.6	42.4	11.88	.78	1.00	1.00
67°F (19°C)	8000	3775	158.0	46.3	8.52	.48	.59	.72	153.2	44.9	9.48	.48	.59	.74	148.0	43.4	10.58	.49	.60	.75	142.8	41.9	11.82	.49	.61	.78
	10000	4720	162.8	47.7	8.64	.50	.63	.82	157.8	46.2	9.60	.51	.64	.84	152.4	44.7	10.70	.51	.66	.86	146.8	43.0	11.94	.52	.68	.89
	12000	5665	166.2	48.7	8.74	.53	.70	.91	161.0	47.2	9.70	.54	.71	.93	155.6	45.6	10.78	.55	.73	.95	149.8	43.9	12.04	.55	.76	.97
71°F (22°C)	8000	3775	167.8	49.2	8.76	.36	.46	.56	162.6	47.7	9.74	.36	.47	.57	157.4	46.1	10.82	.36	.47	.58	151.6	44.4	12.08	.37	.48	.59
	10000	4720	172.4	50.5	8.88	.37	.49	.61	167.2	49.0	9.84	.37	.50	.62	161.4	47.3	10.94	.37	.50	.63	155.4	45.5	12.20	.38	.51	.65
	12000	5665	175.6	51.5	8.96	.38	.52	.67	170.0	49.8	9.94	.38	.53	.69	164.2	48.1	11.02	.39	.54	.71	158.2	46.4	12.28	.39	.55	.73

25 TON STANDARD EFFICIENCY (R-410A) ALL COMPRESSORS OPERATING

LGC300S4

Entering Wet Bulb Temperature	Total Air Volume		Outdoor Air Temperature Entering Outdoor Coil																							
			85°F (29°C)						95°F (35°C)						105°F (41°C)						115°F (46°C)					
			Total Cooling Capacity		Comp Motor kW Input	Sensible To Total Ratio (S/T) Dry Bulb			Total Cooling Capacity		Comp Motor kW Input	Sensible To Total Ratio (S/T) Dry Bulb			Total Cooling Capacity		Comp Motor kW Input	Sensible To Total Ratio (S/T) Dry Bulb			Total Cooling Capacity		Comp Motor kW Input	Sensible To Total Ratio (S/T) Dry Bulb		
			kBtuh	kW		75°F 24°C	80°F 27°C	85°F 29°C	kBtuh	kW		75°F 24°C	80°F 27°C	85°F 29°C	kBtuh	kW		75°F 24°C	80°F 27°C	85°F 29°C	kBtuh	kW		75°F 24°C	80°F 27°C	85°F 29°C
63°F (17°C)	8000	3775	291.5	85.4	20.90	.70	.86	1.00	281.1	82.4	23.41	.71	.88	1.00	270.1	79.2	26.23	.72	.90	1.00	258.4	75.7	29.44	.74	.92	1.00
	10000	4720	302.4	88.6	21.15	.76	.95	1.00	291.7	85.5	23.65	.77	.97	1.00	280.5	82.2	26.51	.79	.99	1.00	268.5	78.7	29.74	.81	1.00	1.00
	12000	5665	311.6	91.3	21.38	.82	1.00	1.00	301.3	88.3	23.92	.84	1.00	1.00	290.1	85.0	26.79	.86	1.00	1.00	278.7	81.7	30.05	.89	1.00	1.00
67°F (19°C)	8000	3775	308.4	90.4	21.30	.55	.68	.82	297.4	87.2	23.81	.55	.69	.84	285.5	83.7	26.67	.56	.70	.86	272.7	79.9	29.89	.57	.71	.88
	10000	4720	317.4	93.0	21.55	.58	.73	.91	305.9	89.7	24.05	.59	.75	.93	293.5	86.0	26.91	.60	.77	.96	280.2	82.1	30.17	.61	.79	.98
	12000	5665	324.1	95.0	21.71	.61	.80	.99	312.2	91.5	24.24	.62	.82	1.00	299.4	87.7	27.11	.63	.84	1.00	286.0	83.8	30.37	.65	.87	1.00
71°F (22°C)	8000	3775	327.8	96.1	21.79	.41	.53	.65	315.9	92.6	24.33	.41	.54	.66	303.4	88.9	27.23	.41	.55	.68	290.1	85.0	30.46	.42	.55	.69
	10000	4720	336.3	98.6	22.03	.42	.57	.71	323.9	94.9	24.57	.42	.58	.73	311.0	91.1	27.43	.43	.59	.74	297.0	87.0	30.67	.43	.60	.76
	12000	5665	342.1	100.3	22.20	.43	.60	.77	329.6	96.6	24.73	.44	.61	.79	316.0	92.6	27.63	.44	.63	.82	301.6	88.4	30.87	.45	.64	.84

HUMIDITROL® REHEAT OPTION RATINGS

13 TON HIGH EFFICIENCY (R-22) COOLING CAPACITY with HUMIDITROL ON TWO COMPRESSORS OPERATING

LGC156H2

Entering Wet Bulb Temperature	Total Air Volume		Outdoor Air Temperature Entering Outdoor Coil																							
			65°F (18°C)						75°F (24°C)						85°F (29°C)						95°F (35°C)					
			Total Cooling Capacity		Comp Motor kW Input	Sensible To Total Ratio (S/T) Dry Bulb			Total Cooling Capacity		Comp Motor kW Input	Sensible To Total Ratio (S/T) Dry Bulb			Total Cooling Capacity		Comp Motor kW Input	Sensible To Total Ratio (S/T) Dry Bulb			Total Cooling Capacity		Comp Motor kW Input	Sensible To Total Ratio (S/T) Dry Bulb		
			kBtuh	kW		75°F 24°C	80°F 27°C	85°F 29°C	kBtuh	kW		75°F 24°C	80°F 27°C	85°F 29°C	kBtuh	kW		75°F 24°C	80°F 27°C	85°F 29°C	kBtuh	kW		75°F 24°C	80°F 27°C	85°F 29°C
63°F (17°C)	4200	1980	57.6	16.9	4.73	0.34	0.62	0.89	50.8	14.9	5.35	0.27	0.60	0.92	44.6	13.1	6.04	0.22	0.60	0.93	36.1	10.6	6.67	0.09	0.55	0.97
	5200	2455	62.2	18.2	4.76	0.45	0.77	1.00	55.2	16.2	5.37	0.42	0.79	1.00	48.8	14.3	6.05	0.38	0.79	1.00	39.9	11.7	6.70	0.32	0.82	1.00
	6200	2925	65.9	19.3	4.78	0.55	0.90	1.00	58.7	17.2	5.39	0.55	0.92	1.00	52.2	15.3	6.07	0.53	0.96	1.00	43.5	12.7	6.72	0.50	0.98	1.00
67°F (19°C)	4200	1980	79.2	23.2	4.77	0.29	0.44	0.63	72.0	21.1	5.38	0.25	0.42	0.63	65.4	19.1	6.07	0.20	0.40	0.63	57.5	16.8	6.71	0.14	0.36	0.63
	5200	2455	83.3	24.4	4.80	0.34	0.52	0.75	76.0	22.3	5.40	0.30	0.51	0.76	69.1	20.2	6.09	0.27	0.49	0.78	61.0	17.9	6.73	0.22	0.48	0.81
	6200	2925	86.4	25.3	4.81	0.37	0.60	0.87	78.8	23.1	5.42	0.35	0.60	0.88	71.8	21.0	6.11	0.32	0.61	0.91	63.5	18.6	6.75	0.28	0.61	0.95
71°F (22°C)	4200	1980	104.4	30.6	4.81	0.28	0.40	0.52	95.9	28.1	5.42	0.24	0.37	0.50	88.1	25.8	6.11	0.20	0.34	0.48	78.8	23.1	6.75	0.14	0.30	0.46
	5200	2455	108.7	31.8	4.84	0.29	0.43	0.57	99.9	29.3	5.44	0.26	0.41	0.56	91.8	26.9	6.12	0.22	0.38	0.55	82.3	24.1	6.76	0.17	0.35	0.55
	6200	2925	111.7	32.7	4.86	0.31	0.47	0.63	102.7	30.1	5.46	0.27	0.45	0.64	94.4	27.6	6.14	0.23	0.43	0.64	84.7	24.8	6.78	0.19	0.40	0.64

13 TON HIGH EFFICIENCY (R-22) COOLING CAPACITY with HUMIDITROL ON ALL COMPRESSORS OPERATING

LGC156H2

Entering Wet Bulb Temperature	Total Air Volume		Outdoor Air Temperature Entering Outdoor Coil																							
			65°F (18°C)						75°F (24°C)						85°F (29°C)						95°F (35°C)					
			Total Cooling Capacity		Comp Motor kW Input	Sensible To Total Ratio (S/T) Dry Bulb			Total Cooling Capacity		Comp Motor kW Input	Sensible To Total Ratio (S/T) Dry Bulb			Total Cooling Capacity		Comp Motor kW Input	Sensible To Total Ratio (S/T) Dry Bulb			Total Cooling Capacity		Comp Motor kW Input	Sensible To Total Ratio (S/T) Dry Bulb		
			kBtuh	kW		75°F 24°C	80°F 27°C	85°F 29°C	kBtuh	kW		75°F 24°C	80°F 27°C	85°F 29°C	kBtuh	kW		75°F 24°C	80°F 27°C	85°F 29°C	kBtuh	kW		75°F 24°C	80°F 27°C	85°F 29°C
63°F (17°C)	4200	1980	111.5	32.6	7.08	0.53	0.73	0.93	103.3	30.2	8.01	0.50	0.73	0.95	95.4	27.9	9.04	0.50	0.75	0.97	85.1	24.9	10.05	0.47	0.74	1.00
	5200	2455	118.4	34.7	7.12	0.61	0.85	1.00	109.8	32.2	8.04	0.60	0.87	1.00	101.7	29.8	9.06	0.60	0.88	1.00	90.9	26.6	10.09	0.58	0.90	1.00
	6200	2925	123.9	36.3	7.16	0.68	0.94	1.00	115.2	33.7	8.07	0.70	0.96	1.00	106.9	31.3	9.09	0.70	0.98	1.00	96.3	28.2	10.12	0.71	1.00	1.00
67°F (19°C)	4200	1980	136.9	40.1	7.14	0.41	0.55	0.71	128.1	37.5	8.06	0.39	0.55	0.71	119.7	35.0	9.09	0.37	0.54	0.72	109.8	32.2	10.11	0.35	0.53	0.73
	5200	2455	143.1	41.9	7.19	0.44	0.62	0.81	134.0	39.2	8.09	0.44	0.61	0.82	125.2	36.7	9.12	0.42	0.62	0.84	115.0	33.7	10.14	0.40	0.61	0.86
	6200	2925	147.7	43.2	7.20	0.48	0.68	0.90	138.3	40.5	8.12	0.48	0.69	0.92	129.2	37.8	9.14	0.46	0.70	0.95	118.7	34.8	10.17	0.45	0.71	0.97
71°F (22°C)	4200	1980	166.3	48.7	7.20	0.34	0.46	0.58	156.0	45.7	8.12	0.32	0.44	0.57	146.2	42.8	9.15	0.29	0.43	0.56	134.8	39.5	10.17	0.26	0.41	0.56
	5200	2455	172.7	50.6	7.25	0.35	0.49	0.63	162.0	47.4	8.15	0.33	0.48	0.64	151.8	44.4	9.17	0.31	0.47	0.64	140.0	41.0	10.19	0.28	0.46	0.63
	6200	2925	177.2	51.9	7.28	0.36	0.																			

HUMIDITROL® REHEAT OPTION RATINGS

13 TON HIGH EFFICIENCY (R-410A) COOLING CAPACITY with HUMIDITROL ON TWO COMPRESSORS OPERATING LGC156H4

Entering Wet Bulb Temperature	Total Air Volume		Outdoor Air Temperature Entering Outdoor Coil																							
			65°F (18°C)						75°F (24°C)						85°F (29°C)						95°F (35°C)					
			Total Cooling Capacity		Comp Motor kW Input	Sensible To Total Ratio (S/T) Dry Bulb			Total Cooling Capacity		Comp Motor kW Input	Sensible To Total Ratio (S/T) Dry Bulb			Total Cooling Capacity		Comp Motor kW Input	Sensible To Total Ratio (S/T) Dry Bulb			Total Cooling Capacity		Comp Motor kW Input	Sensible To Total Ratio (S/T) Dry Bulb		
			kBtuh	kW		75°F 24°C	80°F 27°C	85°F 29°C	kBtuh	kW		75°F 24°C	80°F 27°C	85°F 29°C	kBtuh	kW		75°F 24°C	80°F 27°C	85°F 29°C	kBtuh	kW		75°F 24°C	80°F 27°C	85°F 29°C
63°F (17°C)	4160	1960	62.3	18.3	4.3	0.40	0.64	0.89	52.6	15.4	4.8	0.30	0.61	0.92	44.1	12.9	5.4	0.22	0.60	0.93	34.4	10.1	6.0	0.08	0.56	0.97
	5200	2450	66.8	19.6	4.4	0.50	0.79	1.00	57.1	16.7	4.9	0.45	0.78	1.00	47.3	13.9	5.4	0.38	0.79	1.00	37.9	11.1	6.1	0.30	0.83	1.00
	6240	2940	70.5	20.7	4.4	0.60	0.92	1.00	60.6	17.8	4.9	0.58	0.92	1.00	50.8	14.9	5.4	0.54	0.96	1.00	40.9	12.0	6.1	0.52	1.00	1.00
67°F (19°C)	4160	1960	76.6	22.5	4.4	0.26	0.43	0.63	70.6	20.7	4.9	0.22	0.42	0.63	64.7	19.0	5.5	0.20	0.40	0.64	56.7	16.6	6.1	0.12	0.36	0.64
	5200	2450	80.8	23.7	4.4	0.30	0.52	0.76	74.6	21.9	4.9	0.29	0.51	0.76	67.4	19.8	5.5	0.25	0.49	0.78	60.1	17.6	6.1	0.22	0.49	0.82
	6240	2940	83.8	24.6	4.4	0.36	0.60	0.87	77.4	22.7	4.9	0.34	0.61	0.89	69.6	20.4	5.5	0.31	0.61	0.92	62.6	18.3	6.1	0.28	0.62	0.95
71°F (22°C)	4160	1960	101.5	29.7	4.4	0.25	0.38	0.52	94.9	27.8	4.9	0.23	0.36	0.51	86.9	25.5	5.5	0.19	0.34	0.49	77.8	22.8	6.1	0.13	0.30	0.48
	5200	2450	106.8	31.3	4.5	0.27	0.43	0.58	99.4	29.1	5.0	0.24	0.41	0.58	89.7	26.3	5.5	0.20	0.38	0.57	80.3	23.5	6.2	0.15	0.35	0.55
	6240	2940	109.8	32.2	4.5	0.29	0.47	0.65	100.7	29.5	5.0	0.26	0.45	0.64	92.3	27.1	5.5	0.22	0.42	0.65	81.6	23.9	6.2	0.16	0.40	0.65

13 TON HIGH EFFICIENCY (R-410A) COOLING CAPACITY with HUMIDITROL ON ALL COMPRESSORS OPERATING LGC156H4

Entering Wet Bulb Temperature	Total Air Volume		Outdoor Air Temperature Entering Outdoor Coil																							
			65°F (18°C)						75°F (24°C)						85°F (29°C)						95°F (35°C)					
			Total Cooling Capacity		Comp Motor kW Input	Sensible To Total Ratio (S/T) Dry Bulb			Total Cooling Capacity		Comp Motor kW Input	Sensible To Total Ratio (S/T) Dry Bulb			Total Cooling Capacity		Comp Motor kW Input	Sensible To Total Ratio (S/T) Dry Bulb			Total Cooling Capacity		Comp Motor kW Input	Sensible To Total Ratio (S/T) Dry Bulb		
			kBtuh	kW		75°F 24°C	80°F 27°C	85°F 29°C	kBtuh	kW		75°F 24°C	80°F 27°C	85°F 29°C	kBtuh	kW		75°F 24°C	80°F 27°C	85°F 29°C	kBtuh	kW		75°F 24°C	80°F 27°C	85°F 29°C
63°F (17°C)	4160	1960	99.9	29.3	6.4	0.47	0.70	0.92	89.0	26.1	7.1	0.44	0.69	0.93	85.0	24.9	8.0	0.45	0.73	0.96	67.0	19.6	9.1	0.35	0.68	0.98
	5200	2450	106.8	31.3	6.4	0.57	0.82	1.00	92.6	27.1	7.1	0.53	0.84	1.00	87.6	25.7	8.1	0.54	0.85	1.00	72.7	21.3	9.1	0.51	0.89	1.00
	6240	2940	112.3	32.9	6.5	0.65	0.92	1.00	93.8	27.5	7.2	0.63	0.94	1.00	90.3	26.5	8.1	0.65	0.98	1.00	78.2	22.9	9.2	0.65	1.00	1.00
67°F (19°C)	4160	1960	131.9	38.7	6.5	0.39	0.55	0.71	119.4	35.0	7.2	0.35	0.52	0.70	106.7	31.3	8.0	0.31	0.49	0.71	98.7	28.9	9.1	0.28	0.49	0.73
	5200	2450	136.1	39.9	6.5	0.42	0.60	0.80	122.3	35.8	7.2	0.38	0.59	0.81	110.1	32.3	8.1	0.35	0.59	0.83	101.8	29.8	9.1	0.33	0.58	0.86
	6240	2940	137.6	40.3	6.6	0.45	0.68	0.89	125.6	36.8	7.3	0.43	0.67	0.91	113.1	33.1	8.2	0.40	0.68	0.94	104.5	30.6	9.1	0.40	0.70	0.97
71°F (22°C)	4160	1960	158.5	46.5	6.5	0.31	0.44	0.57	149.5	43.8	7.2	0.29	0.42	0.57	135.7	39.8	8.1	0.24	0.40	0.55	124.5	36.5	9.1	0.21	0.38	0.54
	5200	2450	159.9	46.9	6.6	0.29	0.46	0.62	152.5	44.7	7.3	0.29	0.45	0.62	139.3	40.8	8.1	0.25	0.43	0.61	127.6	37.4	9.2	0.22	0.42	0.62
	6240	2940	164.8	48.3	6.6	0.32	0.50	0.68	155.6	45.6	7.3	0.30	0.50	0.68	143.0	41.9	8.2	0.27	0.49	0.69	131.1	38.4	9.2	0.25	0.48	0.70

15 TON HIGH EFFICIENCY (R-22) COOLING CAPACITY with HUMIDITROL ON TWO COMPRESSORS OPERATING LGC180H2

Entering Wet Bulb Temperature	Total Air Volume		Outdoor Air Temperature Entering Outdoor Coil																							
			65°F (18°C)						75°F (24°C)						85°F (29°C)						95°F (35°C)					
			Total Cooling Capacity		Comp Motor kW Input	Sensible To Total Ratio (S/T) Dry Bulb			Total Cooling Capacity		Comp Motor kW Input	Sensible To Total Ratio (S/T) Dry Bulb			Total Cooling Capacity		Comp Motor kW Input	Sensible To Total Ratio (S/T) Dry Bulb			Total Cooling Capacity		Comp Motor kW Input	Sensible To Total Ratio (S/T) Dry Bulb		
			kBtuh	kW		75°F 24°C	80°F 27°C	85°F 29°C	kBtuh	kW		75°F 24°C	80°F 27°C	85°F 29°C	kBtuh	kW		75°F 24°C	80°F 27°C	85°F 29°C	kBtuh	kW		75°F 24°C	80°F 27°C	85°F 29°C
63°F (17°C)	4800	2265	66.6	19.5	5.91	0.34	0.61	0.86	58.0	17.0	6.63	0.27	0.59	0.89	45.1	13.2	7.42	0.11	0.52	0.89	39.0	11.4	8.14	0.04	0.52	0.94
	6000	2830	71.8	21.0	5.95	0.44	0.76	1.00	62.9	18.4	6.67	0.40	0.75	1.00	49.9	14.6	7.44	0.32	0.75	1.00	43.6	12.8	8.18	0.27	0.78	1.00
	7200	3400	75.8	22.2	5.99	0.55	0.89	1.00	66.9	19.6	6.70	0.54	0.90	1.00	53.7	15.7	7.48	0.47	0.93	1.00	47.4	13.9	8.21	0.47	0.95	1.00
67°F (19°C)	4800	2265	92.2	27.0	5.97	0.29	0.45	0.64	82.2	24.1	6.69	0.22	0.42	0.63	74.9	22.0	7.48	0.19	0.40	0.62	66.5	19.5	8.21	0.12	0.36	0.63
	6000	2830	96.9	28.4	6.01	0.33	0.53	0.75	86.6	25.4	6.73	0.28	0.51	0.76	79.1	22.0	7.52	0.24	0.50	0.76	70.5	20.7	8.24	0.20	0.47	0.78
	7200	3400	100.2	29.4	6.05	0.38	0.61	0.86	89.9	26.3	6.76	0.34	0.59	0.87	82.2	24.1	7.54	0.30	0.60	0.88	73.4	21.5	8.28	0.27	0.59	0.91
71°F (22°C)	4800	2265	119.4	35.0	6.05	0.26	0.39	0.52	110.1	32.3	6.77	0.23	0.37	0.51	102.7	30.1	7.56	0.20	0.34	0.49	91.9	26.9	8.29	0.13	0.31	0.46
	6000	2830	124.1	36.4	6.09	0.27	0.43	0.57	114.6	33.6	6.82	0.23	0.40	0.57	106.9	31.3	7.60	0.22	0.39	0.56	95.9	28.1	8.32	0.16	0.36	0.56
	7200	3400	127.4	37.3	6.12	0.28	0.47	0.64	117.7	34.5	6.84	0.25	0.44	0.64	109.8	32.2	7.62	0.24	0.43	0.64	98.6	28.9	8.35	0.18	0.41	0.65

15 TON HIGH EFFICIENCY (R-22) COOLING CAPACITY with HUMIDITROL ON ALL COMPRESSORS OPERATING LGC180H2

Entering Wet Bulb Temperature	Total Air Volume		Outdoor Air Temperature Entering Outdoor Coil																							
			65°F (18°C)						75°F (24°C)						85°F (29°C)						95°F (35°C)					
			Total Cooling Capacity		Comp Motor kW Input	Sensible To Total Ratio (S/T) Dry Bulb			Total Cooling Capacity		Comp Motor kW Input	Sensible To Total Ratio (S/T) Dry Bulb			Total Cooling Capacity		Comp Motor kW Input	Sensible To Total Ratio (S/T) Dry Bulb			Total Cooling Capacity		Comp Motor kW Input	Sensible To Total Ratio (S/T) Dry Bulb		
			kBtuh	kW		75°F 24°C	80°F 27°C	85°F 29°C	kBtuh	kW		75°F 24°C	80°F 27°C	85°F 29°C	kBtuh	kW		75°F 24°C	80°F 27°C	85°F 29°C	kBtuh	kW		75°F 24°C	80°F 27°C	85°F 29°C
63°F (17°C)	4800	2265	126.3	37.01	8.87	0.51	0.70	0.90	116.0	34.0	9.95	0.50	0.70	0.92	101.3	29.7	11.16	0.44	0.70	0.93	93.3	27.3	12.36	0.43	0.71	0.96
	6000	2830	133.9	39.2	8.93	0.58	0.81	1.00	123.3	36.1	10.01	0.57	0.83	1.00	108.3	31.7	11.20	0.54	0.80	1.00	100.0	29.3	12.42	0.56	0.86	1.00
	7200	3400	139.8	41.0	8.98	0.65	0.91	1.00	129.2	37.9	10.05	0.67	0.92	1.00	113.9	33.4	11.26	0.65	0.95	1.00	105.6	30.9	12.47	0.67	0.97	1.00
67°F (19°C)	4800	2265	155.9	45.7	8.96	0.39	0.54	0.70	144.2	42.3	10.04	0.36	0.53	0.70	134.8	39.5	11.25	0.36	0.52	0.71	124.3	36.4	12.47	0.33	0.52	0.71
	6000	2830	162.7	47.7	9.02	0.43	0.60	0.80	150.6	44.1	10.10	0.41	0.60	0.80	141.0	41.3	11.31	0.39	0.60	0.82	130.1	38.1	12.52	0.38	0.60	0.83
	7200	3400	167.6	49.1	9.08	0.47	0.67	0.89	155.3	45.5	10.15	0.46	0.67	0.89	145.4	42.6	11.35	0.44	0.67	0.92	134.4	39.4	12.58	0.43	0.69	0.93
71°F (22°C)	4800	2265	187.3	54.9	9.08	0.31	0.44	0.57	176.2	51.6	10.16	0.29	0.43	0.56	166.6	48.8	11.37	0.27	0.42	0.55	153.6	45.0	12.59	0.25	0.39	0.54
	6000	2830	194.3	56.9	9.14	0.33	0.48	0.61	182.8	53.6	10.23	0.31	0.46	0.61	172.7	50.6	11.44	0.29	0.46	0.63	159.4	46.7	12.64	0.27	0.45	0.62
	7200	3400	199.2	58.4	9.19	0.34	0.51	0.67</																		

HUMIDITROL® REHEAT OPTION RATINGS

15 TON HIGH EFFICIENCY (R-410A) COOLING CAPACITY with HUMIDITROL ON - TWO COMPRESSOR OPERATING LGC180H4

Entering Wet Bulb Temperature	Total Air Volume		Outdoor Air Temperature Entering Outdoor Coil																							
			65°F (18°C)						75°F (24°C)						85°F (29°C)						95°F (35°C)					
			Total Cooling Capacity		Comp Motor kW Input	Sensible To Total Ratio (S/T)			Total Cooling Capacity		Comp Motor kW Input	Sensible To Total Ratio (S/T)			Total Cooling Capacity		Comp Motor kW Input	Sensible To Total Ratio (S/T)			Total Cooling Capacity		Comp Motor kW Input	Sensible To Total Ratio (S/T)		
						Dry Bulb						Dry Bulb						Dry Bulb						Dry Bulb		
cfm	L/s	kBtuh	kW	75°F 24°C	80°F 27°C	85°F 29°C	kBtuh	kW	75°F 24°C	80°F 27°C	85°F 29°C	kBtuh	kW	75°F 24°C	80°F 27°C	85°F 29°C	kBtuh	kW	75°F 24°C	80°F 27°C	85°F 29°C	kBtuh	kW	75°F 24°C	80°F 27°C	85°F 29°C
63°F (17°C)	4800	2270	83.8	24.6	5.4	0.48	0.68	0.88	74.6	21.9	6.1	0.45	0.68	0.90	57.2	16.8	6.8	0.34	0.63	0.92	44.8	13.1	7.7	0.23	0.63	0.95
	6000	2830	89.2	26.1	5.4	0.55	0.79	0.97	79.6	23.3	6.1	0.53	0.81	0.98	62.0	18.2	6.9	0.47	0.80	1.00	49.3	14.4	7.7	0.41	0.84	1.00
	7200	3400	93.4	27.4	5.5	0.63	0.90	1.00	83.7	24.5	6.2	0.63	0.92	1.00	65.9	19.3	6.9	0.60	0.92	1.00	54.3	15.9	7.8	0.58	0.96	1.00
67°F (19°C)	4800	2270	105.2	30.8	5.4	0.37	0.51	0.67	94.8	27.8	6.1	0.34	0.50	0.68	83.2	24.4	6.9	0.28	0.47	0.68	70.0	20.5	7.7	0.21	0.43	0.67
	6000	2830	110.1	32.3	5.5	0.40	0.59	0.78	99.4	29.1	6.2	0.38	0.57	0.78	87.4	25.6	6.9	0.34	0.55	0.81	73.9	21.7	7.8	0.28	0.53	0.82
	7200	3400	113.5	33.3	5.5	0.45	0.65	0.86	102.6	30.1	6.2	0.43	0.64	0.88	90.4	26.5	7.0	0.39	0.64	0.91	76.7	22.5	7.8	0.34	0.65	0.93
71°F (22°C)	4800	2270	127.8	37.5	5.5	0.31	0.42	0.55	118.1	34.6	6.2	0.28	0.41	0.54	107.4	31.5	6.9	0.24	0.38	0.53	93.4	27.4	7.8	0.17	0.34	0.50
	6000	2830	132.7	38.9	5.6	0.31	0.46	0.60	122.7	36.0	6.3	0.30	0.45	0.61	111.6	32.7	7.0	0.26	0.42	0.60	97.2	28.5	7.8	0.19	0.40	0.59
	7200	3400	136.2	39.9	5.6	0.32	0.50	0.66	125.8	36.9	6.3	0.31	0.49	0.67	114.6	33.6	7.0	0.28	0.48	0.68	99.8	29.2	7.9	0.23	0.44	0.67

15 TON HIGH EFFICIENCY (R-410A) COOLING CAPACITY with HUMIDITROL ON - ALL COMPRESSOR OPERATING LGC180H4

Entering Wet Bulb Temperature	Total Air Volume		Outdoor Air Temperature Entering Outdoor Coil																							
			65°F (18°C)						75°F (24°C)						85°F (29°C)						95°F (35°C)					
			Total Cooling Capacity		Comp Motor kW Input	Sensible To Total Ratio (S/T)			Total Cooling Capacity		Comp Motor kW Input	Sensible To Total Ratio (S/T)			Total Cooling Capacity		Comp Motor kW Input	Sensible To Total Ratio (S/T)			Total Cooling Capacity		Comp Motor kW Input	Sensible To Total Ratio (S/T)		
						Dry Bulb						Dry Bulb						Dry Bulb						Dry Bulb		
cfm	L/s	kBtuh	kW	75°F 24°C	80°F 27°C	85°F 29°C	kBtuh	kW	75°F 24°C	80°F 27°C	85°F 29°C	kBtuh	kW	75°F 24°C	80°F 27°C	85°F 29°C	kBtuh	kW	75°F 24°C	80°F 27°C	85°F 29°C	kBtuh	kW	75°F 24°C	80°F 27°C	85°F 29°C
63°F (17°C)	4800	2270	148.9	43.6	7.9	0.57	0.74	0.91	137.2	40.2	8.9	0.56	0.75	0.93	117.2	34.3	10.1	0.53	0.74	0.95	102.1	29.9	11.4	0.50	0.75	0.97
	6000	2830	156.8	46.0	8.0	0.63	0.83	0.99	144.7	42.4	8.9	0.62	0.85	0.99	124.4	36.5	10.1	0.61	0.87	1.00	108.7	31.9	11.5	0.61	0.89	1.00
	7200	3400	163.1	47.8	8.1	0.69	0.91	1.00	150.8	44.2	9.0	0.71	0.93	1.00	130.3	38.2	10.2	0.71	0.96	1.00	114.8	33.6	11.6	0.71	0.98	1.00
67°F (19°C)	4800	2270	174.6	51.2	8.0	0.44	0.57	0.71	161.5	47.3	9.0	0.42	0.57	0.73	147.1	43.1	10.1	0.40	0.56	0.74	130.8	38.3	11.5	0.38	0.54	0.75
	6000	2830	181.8	53.3	8.1	0.47	0.63	0.80	168.3	49.3	9.0	0.46	0.63	0.82	153.3	44.9	10.2	0.45	0.63	0.85	136.6	40.0	11.5	0.42	0.63	0.86
	7200	3400	186.9	54.8	8.1	0.51	0.69	0.88	173.1	50.7	9.1	0.50	0.70	0.90	157.8	46.2	10.3	0.49	0.71	0.92	140.8	41.3	11.6	0.47	0.73	0.96
71°F (22°C)	4800	2270	201.8	59.1	8.1	0.34	0.46	0.58	189.3	55.5	9.0	0.32	0.45	0.58	175.5	51.4	10.2	0.30	0.44	0.58	158.3	46.4	11.6	0.28	0.42	0.57
	6000	2830	209.0	61.3	8.2	0.35	0.50	0.63	196.0	57.4	9.1	0.34	0.48	0.64	181.8	53.3	10.3	0.32	0.48	0.64	164.0	48.1	11.6	0.29	0.46	0.65
	7200	3400	214.2	62.8	8.2	0.37	0.52	0.68	200.7	58.8	9.1	0.35	0.52	0.70	186.1	54.5	10.3	0.34	0.52	0.71	167.7	49.2	11.7	0.31	0.51	0.72

17.5 TON HIGH EFFICIENCY (R-22) COOLING CAPACITY with HUMIDITROL ON TWO COMPRESSORS OPERATING LGC210H2

Entering Wet Bulb Temperature	Total Air Volume		Outdoor Air Temperature Entering Outdoor Coil																							
			65°F (18°C)						75°F (24°C)						85°F (29°C)						95°F (35°C)					
			Total Cooling Capacity		Comp Motor kW Input	Sensible To Total Ratio (S/T)			Total Cooling Capacity		Comp Motor kW Input	Sensible To Total Ratio (S/T)			Total Cooling Capacity		Comp Motor kW Input	Sensible To Total Ratio (S/T)			Total Cooling Capacity		Comp Motor kW Input	Sensible To Total Ratio (S/T)		
						Dry Bulb						Dry Bulb						Dry Bulb						Dry Bulb		
cfm	L/s	kBtuh	kW	75°F 24°C	80°F 27°C	85°F 29°C	kBtuh	kW	75°F 24°C	80°F 27°C	85°F 29°C	kBtuh	kW	75°F 24°C	80°F 27°C	85°F 29°C	kBtuh	kW	75°F 24°C	80°F 27°C	85°F 29°C	kBtuh	kW	75°F 24°C	80°F 27°C	85°F 29°C
63°F (17°C)	5600	2645	45.2	13.2	4.94	0.15	0.52	0.90	40.2	11.8	5.37	0.10	0.52	0.95	32.6	9.5	5.84	-0.04	0.50	1.00	23.8	6.7	6.51	-0.33	0.42	1.00
	7000	3305	50.0	14.6	4.98	0.32	0.77	1.00	44.6	13.1	5.39	0.28	0.78	1.00	36.8	10.8	5.88	0.22	0.83	1.00	27.8	8.1	6.54	0.08	0.85	1.00
	8400	3965	53.6	15.7	5.00	0.50	0.93	1.00	48.2	14.1	5.43	0.50	0.98	1.00	40.6	11.9	5.90	0.46	1.00	1.00	32.0	9.4	6.56	0.43	1.00	1.00
67°F (19°C)	5600	2645	68.6	20.1	5.00	0.17	0.35	0.59	63.2	18.5	5.41	0.12	0.34	0.61	55.4	16.2	5.90	0.05	0.29	0.59	46.2	13.5	6.56	-0.09	0.20	0.57
	7000	3305	72.8	21.3	5.02	0.24	0.47	0.75	67.0	19.6	5.45	0.20	0.46	0.77	59.0	17.3	5.94	0.14	0.43	0.81	49.6	14.5	6.60	0.04	0.39	0.82
	8400	3965	75.8	22.2	5.06	0.30	0.58	0.90	69.8	20.4	5.47	0.28	0.59	0.93	61.6	18.0	5.96	0.21	0.59	0.96	52.0	15.2	6.62	0.12	0.57	1.00
71°F (22°C)	5600	2645	97.8	28.6	5.06	0.21	0.35	0.49	92.0	26.9	5.49	0.18	0.34	0.49	83.8	24.5	5.96	0.15	0.30	0.47	74.4	21.8	6.62	0.08	0.26	0.44
	7000	3305	102.0	29.9	5.10	0.23	0.39	0.56	95.8	28.1	5.51	0.21	0.39	0.56	87.4	25.6	6.00	0.17	0.37	0.56	77.6	22.7	6.66	0.11	0.33	0.54
	8400	3965	104.8	30.7	5.12	0.25	0.45	0.64	98.4	28.8	5.55	0.24	0.44	0.65	89.8	26.3	6.01	0.19	0.41	0.66	79.8	23.4	6.67	0.13	0.39	0.66

17.5 TON HIGH EFFICIENCY (R-22) COOLING CAPACITY with HUMIDITROL ON ALL COMPRESSORS OPERATING LGC210H2

Entering Wet Bulb Temperature	Total Air Volume		Outdoor Air Temperature Entering Outdoor Coil																							
			65°F (18°C)						75°F (24°C)						85°F (29°C)						95°F (35°C)					
			Total Cooling Capacity		Comp Motor kW Input	Sensible To Total Ratio (S/T)			Total Cooling Capacity		Comp Motor kW Input	Sensible To Total Ratio (S/T)			Total Cooling Capacity		Comp Motor kW Input	Sensible To Total Ratio (S/T)			Total Cooling Capacity		Comp Motor kW Input	Sensible To Total Ratio (S/T)		
						Dry Bulb						Dry Bulb						Dry Bulb						Dry Bulb		
cfm	L/s	kBtuh	kW	75°F 24°C	80°F 27°C	85°F 29°C	kBtuh	kW	75°F 24°C	80°F 27°C	85°F 29°C	kBtuh	kW	75°F 24°C	80°F 27°C	85°F 29°C	kBtuh	kW	75°F 24°C	80°F 27°C	85°F 29°C	kBtuh	kW	75°F 24°C	80°F 27°C	85°F 29°C
63°F (17°C)	5600	2645	155.4	45.5	10.02	0.52	0.73	0.94	147.2	43.1	11.09	0.52	0.75	0.97	136.1	39.9	12.29	0.52	0.76	1.00	123.4	36.1	13.79	0.50	0.77	1.00
	7000	3305	164.8	48.3	10.08	0.61	0.86	1.00	156.0	45.7	11.15	0.62	0.89	1.00	144.5	42.3	12.36	0.61	0.91	1.00	131.5	38.5	13.87	0.62	0.94	1.00
	8400	3965	172.2	50.4	10.14	0.70	0.97	1.00	163.4	47.8	11.21	0.72	0.99	1.00	152.1	44.5	12.42	0.72	1.00	1.00	139.8	40.9	13.90	0.74	1.00	1.00
67°F (19°C)	5600	2645	186.2	54.5	10.12	0.40	0.55	0.71	177.2	51.9	11.91	0.40	0.55	0.73	165.7	48.5	12.40	0.38	0.55	0.73	152.2	44.6	13.90	0.36	0.54	0.75
	7000	3305	194.6	57.0	10.18	0.44	0.61	0.83	185.0	54.2	11.27	0.44	0.62	0.85	172.8	50.6	12.50	0.42	0.63	0.87	159.0	46.6	13.98	0.41	0.63	0.89
	8400	3965	200.6	58.7	10.26	0.48	0.69	0.93	190.6	55.8	11.31	0.48	0.71	0.95	178.1	52.1	12.54	0.48	0.71	0.97	163.9	48.0	14.02	0.47	0.74	1.00
71°F (22°C)	5600	2645	223.6	65.5	10.26	0.32	0.45	0.57	214																	

HUMIDITROL® REHEAT OPTION RATINGS

17.5 TON HIGH EFFICIENCY (R-410A) COOLING CAPACITY with HUMIDITROL ON TWO COMPRESSORS OPERATING LGC210H4

Entering Wet Bulb Temperature	Total Air Volume		Outdoor Air Temperature Entering Outdoor Coil																							
			65°F (18°C)						75°F (24°C)						85°F (29°C)						95°F (35°C)					
			Total Cooling Capacity		Comp Motor kW Input	Sensible To Total Ratio (S/T) Dry Bulb			Total Cooling Capacity		Comp Motor kW Input	Sensible To Total Ratio (S/T) Dry Bulb			Total Cooling Capacity		Comp Motor kW Input	Sensible To Total Ratio (S/T) Dry Bulb			Total Cooling Capacity		Comp Motor kW Input	Sensible To Total Ratio (S/T) Dry Bulb		
			kBtuh	kW		75°F 24°C	80°F 27°C	85°F 29°C	kBtuh	kW		75°F 24°C	80°F 27°C	85°F 29°C	kBtuh	kW		75°F 24°C	80°F 27°C	85°F 29°C	kBtuh	kW		75°F 24°C	80°F 27°C	85°F 29°C
63°F (17°C)	5600	2640	82.2	24.1	4.5	0.54	0.73	0.95	64.0	18.8	5.0	0.45	0.70	0.95	47.5	13.9	5.5	0.30	0.65	0.98	32.7	9.6	6.1	0.03	0.59	1.00
	7000	3300	85.1	24.9	4.5	0.61	0.85	1.00	66.3	19.4	5.0	0.53	0.85	1.00	49.4	14.5	5.5	0.43	0.87	1.00	34.0	10.0	6.1	0.25	0.87	1.00
	8400	3960	88.1	25.8	4.6	0.69	0.96	1.00	68.6	20.1	5.1	0.64	0.98	1.00	51.3	15.0	5.5	0.58	1.00	1.00	35.6	10.4	6.1	0.49	1.00	1.00
67°F (19°C)	5600	2640	88.3	25.9	4.6	0.36	0.52	0.68	75.0	22.0	5.0	0.27	0.45	0.66	57.8	16.9	5.5	0.10	0.33	0.62	43.2	12.7	6.1	-0.14	0.18	0.58
	7000	3300	91.7	26.9	4.6	0.40	0.57	0.80	77.8	22.8	5.1	0.32	0.54	0.82	59.9	17.6	5.6	0.16	0.44	0.81	45.2	13.2	6.2	-0.06	0.36	0.83
	8400	3960	94.6	27.7	4.7	0.44	0.67	0.92	80.4	23.5	5.1	0.38	0.64	0.94	61.9	18.1	5.6	0.24	0.60	0.96	46.7	13.7	6.2	0.04	0.53	1.00
71°F (22°C)	5600	2640	104.4	30.6	4.6	0.27	0.40	0.53	90.7	26.6	5.1	0.18	0.34	0.49	72.7	21.3	5.7	0.01	0.21	0.40	54.4	15.9	6.2	-0.26	-0.01	0.25
	7000	3300	108.1	31.7	4.7	0.28	0.44	0.59	93.8	27.5	5.2	0.20	0.38	0.56	75.3	22.1	5.7	0.05	0.28	0.50	56.5	16.6	6.2	-0.23	0.08	0.40
	8400	3960	111.6	32.7	4.7	0.30	0.48	0.67	96.7	28.3	5.2	0.23	0.43	0.66	77.7	22.8	5.7	0.08	0.35	0.62	58.2	17.1	6.3	-0.19	0.18	0.57

17.5 TON HIGH EFFICIENCY (R-410A) COOLING CAPACITY with HUMIDITROL ON ALL COMPRESSORS OPERATING LGC210H4

Entering Wet Bulb Temperature	Total Air Volume		Outdoor Air Temperature Entering Outdoor Coil																							
			65°F (18°C)						75°F (24°C)						85°F (29°C)						95°F (35°C)					
			Total Cooling Capacity		Comp Motor kW Input	Sensible To Total Ratio (S/T) Dry Bulb			Total Cooling Capacity		Comp Motor kW Input	Sensible To Total Ratio (S/T) Dry Bulb			Total Cooling Capacity		Comp Motor kW Input	Sensible To Total Ratio (S/T) Dry Bulb			Total Cooling Capacity		Comp Motor kW Input	Sensible To Total Ratio (S/T) Dry Bulb		
			kBtuh	kW		75°F 24°C	80°F 27°C	85°F 29°C	kBtuh	kW		75°F 24°C	80°F 27°C	85°F 29°C	kBtuh	kW		75°F 24°C	80°F 27°C	85°F 29°C	kBtuh	kW		75°F 24°C	80°F 27°C	85°F 29°C
63°F (17°C)	5600	2640	182.0	53.3	9.2	0.66	0.82	0.96	163.6	47.9	10.3	0.65	0.82	0.97	144.7	42.4	11.6	0.63	0.83	1.00	127.1	37.2	13.0	0.61	0.85	1.00
	7000	3300	188.6	55.3	9.2	0.72	0.90	1.00	169.3	49.6	10.3	0.71	0.92	1.00	149.9	43.9	11.6	0.72	0.93	1.00	131.5	38.5	13.0	0.72	0.95	1.00
	8400	3960	195.1	57.2	9.3	0.78	0.98	1.00	174.9	51.3	10.4	0.79	0.99	1.00	155.0	45.4	11.6	0.79	1.00	1.00	136.1	39.9	13.0	0.81	1.00	1.00
67°F (19°C)	5600	2640	203.1	59.5	9.4	0.49	0.64	0.78	185.4	54.3	10.4	0.47	0.63	0.79	165.0	48.4	11.6	0.43	0.62	0.80	140.4	41.1	13.1	0.38	0.60	0.79
	7000	3300	210.5	61.7	9.4	0.53	0.71	0.87	192.0	56.3	10.4	0.51	0.71	0.88	170.8	50.1	11.7	0.49	0.70	0.89	145.7	42.7	13.1	0.44	0.69	0.93
	8400	3960	217.6	63.8	9.4	0.58	0.77	0.94	198.6	58.2	10.4	0.56	0.78	0.96	176.6	51.8	11.7	0.54	0.78	0.99	150.3	44.1	13.1	0.50	0.79	1.00
71°F (22°C)	5600	2640	228.0	66.8	9.5	0.36	0.49	0.63	206.6	60.6	10.6	0.33	0.47	0.61	186.0	54.5	11.8	0.29	0.45	0.61	164.3	48.1	13.2	0.23	0.42	0.59
	7000	3300	236.1	69.2	9.5	0.38	0.54	0.69	213.8	62.7	10.6	0.35	0.52	0.68	192.3	56.4	11.8	0.30	0.50	0.69	170.2	49.9	13.2	0.26	0.47	0.69
	8400	3960	243.9	71.5	9.6	0.40	0.58	0.76	220.8	64.7	10.7	0.36	0.57	0.76	198.6	58.2	11.8	0.34	0.56	0.77	175.7	51.5	13.2	0.28	0.53	0.77

20 TON HIGH EFFICIENCY (R-22) COOLING CAPACITY with HUMIDITROL ON TWO COMPRESSORS OPERATING LGA240H2

Entering Wet Bulb Temperature	Total Air Volume		Outdoor Air Temperature Entering Outdoor Coil																							
			65°F (18°C)						75°F (24°C)						85°F (29°C)						95°F (35°C)					
			Total Cooling Capacity		Comp Motor kW Input	Sensible To Total Ratio (S/T) Dry Bulb			Total Cooling Capacity		Comp Motor kW Input	Sensible To Total Ratio (S/T) Dry Bulb			Total Cooling Capacity		Comp Motor kW Input	Sensible To Total Ratio (S/T) Dry Bulb			Total Cooling Capacity		Comp Motor kW Input	Sensible To Total Ratio (S/T) Dry Bulb		
			kBtuh	kW		75°F 24°C	80°F 27°C	85°F 29°C	kBtuh	kW		75°F 24°C	80°F 27°C	85°F 29°C	kBtuh	kW		75°F 24°C	80°F 27°C	85°F 29°C	kBtuh	kW		75°F 24°C	80°F 27°C	85°F 29°C
63°F (17°C)	6400	3020	51.6	15.1	6.08	0.09	0.46	0.85	41.8	12.3	6.72	-0.06	0.41	0.85	30.8	9.0	7.37	-0.35	0.27	0.88	19.8	5.8	8.13	-0.97	0.01	0.94
	8000	3775	56.6	16.6	6.14	0.26	0.70	1.00	46.8	13.7	6.75	0.15	0.70	1.00	35.6	10.4	7.43	-0.01	0.69	1.00	24.2	7.1	8.19	-0.33	0.66	1.00
	9600	4530	60.8	17.8	6.18	0.42	0.89	1.00	50.8	14.9	6.81	0.38	0.92	1.00	39.6	11.6	7.46	0.29	0.94	1.00	28.4	8.3	8.24	-0.13	1.00	1.00
67°F (19°C)	6400	3020	78.6	23.0	6.16	0.14	0.33	0.55	69.6	20.4	6.79	0.06	0.29	0.53	58.4	17.1	7.44	-0.06	0.18	0.50	46.8	13.7	8.22	-0.28	0.04	0.45
	8000	3775	83.2	24.4	6.22	0.20	0.41	0.72	73.8	21.6	6.85	0.14	0.40	0.73	62.4	18.3	7.50	0.04	0.33	0.73	50.6	14.9	8.27	-0.14	0.26	0.73
	9600	4530	86.4	25.3	6.24	0.26	0.54	0.85	77.0	22.6	6.87	0.21	0.52	0.87	65.4	19.2	7.54	0.12	0.49	0.90	53.4	15.7	8.32	-0.01	0.45	0.93
71°F (22°C)	6400	3020	106.6	31.2	6.26	0.16	0.30	0.45	101.4	29.7	6.89	0.15	0.30	0.44	91.8	26.9	7.56	0.09	0.25	0.41	84.8	24.8	8.33	0.05	0.23	0.40
	8000	3775	111.0	32.5	6.30	0.19	0.35	0.51	105.4	30.9	6.95	0.17	0.35	0.51	95.6	28.0	7.59	0.12	0.30	0.51	88.6	26.0	8.37	0.08	0.29	0.50
	9600	4530	114.2	33.5	6.34	0.21	0.39	0.59	108.4	31.8	6.96	0.19	0.39	0.59	98.4	28.8	7.65	0.14	0.37	0.60	91.0	26.7	8.41	0.12	0.36	0.61

20 TON HIGH EFFICIENCY (R-22) COOLING CAPACITY with HUMIDITROL ON ALL COMPRESSORS OPERATING LGA240H2

Entering Wet Bulb Temperature	Total Air Volume		Outdoor Air Temperature Entering Outdoor Coil																							
			65°F (18°C)						75°F (24°C)						85°F (29°C)						95°F (35°C)					
			Total Cooling Capacity		Comp Motor kW Input	Sensible To Total Ratio (S/T) Dry Bulb			Total Cooling Capacity		Comp Motor kW Input	Sensible To Total Ratio (S/T) Dry Bulb			Total Cooling Capacity		Comp Motor kW Input	Sensible To Total Ratio (S/T) Dry Bulb			Total Cooling Capacity		Comp Motor kW Input	Sensible To Total Ratio (S/T) Dry Bulb		
			kBtuh	kW		75°F 24°C	80°F 27°C	85°F 29°C	kBtuh	kW		75°F 24°C	80°F 27°C	85°F 29°C	kBtuh	kW		75°F 24°C	80°F 27°C	85°F 29°C	kBtuh	kW		75°F 24°C	80°F 27°C	85°F 29°C
63°F (17°C)	6400	3020	178.9	52.4	12.22	0.55	0.74	0.94	165.6	48.5	13.62	0.54	0.75	0.96	150.4	44.0	15.19	0.52	0.76	0.98	135.2	39.6	16.95	0.51	0.76	1.00
	8000	3775	189.0	55.4	12.34	0.62	0.86	1.00	175.4	51.4	13.73	0.62	0.87	1.00	160.0	46.9	15.27	0.61	0.89	1.00	144.2	42.3	17.05	0.62	0.92	1.00
	9600	4530	197.4	57.9	12.42	0.71	0.96	1.00	183.6	53.8	13.81	0.71	0.97	1.00	168.0	49.2	15.37	0.71	1.00	1.00	152.6	44.7	17.15	0.72	1.00	1.00
67°F (19°C)	6400	3020	214.0	62.7	12.40	0.42	0.57	0.72	201.0	58.9	13.78	0.40	0.56	0.73	185.4	54.3	15.34	0.38	0.55	0.74	169.3	49.6	17.13	0.35	0.54	0.74
	8000	3775	223.2	65.4	12.50	0.45	0.64	0.82	209.8	61.5	13.89	0.44	0.63	0.85	193.6	56.7	15.43	0.43	0.64	0.85	177.0	51.9	17.21	0.40	0.63	0.87
	9600	4530	230.0	67.4	12.57	0.49	0.70	0.93	216.1	63.3	13.97	0.49	0.72	0.94	199.5	58.5	15.54	0.48	0.72	0.96	182.6	53.5	17.32	0.46	0.73	0.99
71°F (22°C)	6400	3020	251.3	73.6	12.58	0.32	0.45	0.58	241.6	70.8	13.97	0.32	0.44	0.58	227.3	66.6	15.54	0.30	0.44	0.58	215.5	63.2	17.35	0.29	0.43	0.59
	8000	3775	260.2	76.3	12.68	0.33	0.49	0.63	250.0	73.3	14.09	0.33	0.49	0.64	235.1	68.9	15.65	0.31	0.48	0.65	225.0	65.4	17.43	0.30	0.48	0.66
	9600	4530	266.3	78.0																						

HUMIDITROL® REHEAT OPTION RATINGS

20 TON HIGH EFFICIENCY (R-410A) COOLING CAPACITY with HUMIDITROL ON - TWO COMPRESSOR OPERATING LGA240H4

Entering Wet Bulb Temperature	Total Air Volume		Outdoor Air Temperature Entering Outdoor Coil																							
			65°F (18°C)						75°F (24°C)						85°F (29°C)						95°F (35°C)					
			Total Cooling Capacity		Comp Motor kW Input	Sensible To Total Ratio (S/T)			Total Cooling Capacity		Comp Motor kW Input	Sensible To Total Ratio (S/T)			Total Cooling Capacity		Comp Motor kW Input	Sensible To Total Ratio (S/T)			Total Cooling Capacity		Comp Motor kW Input	Sensible To Total Ratio (S/T)		
						Dry Bulb						Dry Bulb						Dry Bulb						Dry Bulb		
cfm	L/s	kBtuh	kW	75°F 24°C	80°F 27°C	85°F 29°C	kBtuh	kW	75°F 24°C	80°F 27°C	85°F 29°C	kBtuh	kW	75°F 24°C	80°F 27°C	85°F 29°C	kBtuh	kW	75°F 24°C	80°F 27°C	85°F 29°C	kBtuh	kW	75°F 24°C	80°F 27°C	85°F 29°C
63°F (17°C)	6400	3020	64.4	18.9	3.8	0.30	0.58	0.87	61.4	18.0	4.6	0.31	0.61	0.91	57.9	17.0	5.5	0.32	0.64	0.94	54.1	15.9	6.4	0.32	0.69	0.96
	8000	3780	69.4	20.3	3.9	0.41	0.75	0.98	66.1	19.4	4.6	0.44	0.80	1.00	62.4	18.3	5.5	0.45	0.84	1.00	58.4	17.1	6.4	0.50	0.89	1.00
	9600	4530	73.5	21.5	3.9	0.55	0.90	1.00	70.1	20.5	4.7	0.58	0.93	1.00	66.5	19.5	5.6	0.61	0.96	1.00	62.6	18.3	6.5	0.64	0.98	1.00
67°F (19°C)	6400	3020	72.1	21.1	3.9	0.11	0.30	0.53	68.6	20.1	4.7	0.12	0.31	0.56	64.8	19.0	5.5	0.10	0.32	0.59	60.6	17.8	6.5	0.10	0.32	0.62
	8000	3780	76.5	22.4	3.9	0.18	0.40	0.69	72.8	21.3	4.7	0.17	0.41	0.74	68.7	20.1	5.6	0.18	0.44	0.77	64.2	18.8	6.5	0.18	0.46	0.82
	9600	4530	79.8	23.4	4.0	0.25	0.51	0.85	75.8	22.2	4.8	0.24	0.54	0.88	71.5	21.0	5.6	0.24	0.57	0.93	66.7	19.5	6.6	0.26	0.61	0.96
71°F (22°C)	6400	3020	80.7	23.7	4.0	-0.05	0.13	0.30	76.8	22.5	4.8	-0.05	0.12	0.31	72.7	21.3	5.6	-0.06	0.13	0.32	68.0	19.9	6.6	-0.08	0.13	0.32
	8000	3780	85.1	24.9	4.1	-0.01	0.18	0.40	80.9	23.7	4.8	-0.02	0.19	0.41	76.3	22.4	5.7	-0.02	0.20	0.41	71.4	20.9	6.6	-0.04	0.20	0.44
	9600	4530	88.0	25.8	4.2	0.02	0.24	0.48	83.5	24.5	4.9	0.02	0.25	0.51	78.7	23.1	5.7	0.01	0.27	0.55	73.7	21.6	6.7	-0.01	0.28	0.58

20 TON HIGH EFFICIENCY (R-410A) COOLING CAPACITY with HUMIDITROL ON - ALL COMPRESSOR OPERATING LGA240H4

Entering Wet Bulb Temperature	Total Air Volume		Outdoor Air Temperature Entering Outdoor Coil																							
			65°F (18°C)						75°F (24°C)						85°F (29°C)						95°F (35°C)					
			Total Cooling Capacity		Comp Motor kW Input	Sensible To Total Ratio (S/T)			Total Cooling Capacity		Comp Motor kW Input	Sensible To Total Ratio (S/T)			Total Cooling Capacity		Comp Motor kW Input	Sensible To Total Ratio (S/T)			Total Cooling Capacity		Comp Motor kW Input	Sensible To Total Ratio (S/T)		
						Dry Bulb						Dry Bulb						Dry Bulb						Dry Bulb		
cfm	L/s	kBtuh	kW	75°F 24°C	80°F 27°C	85°F 29°C	kBtuh	kW	75°F 24°C	80°F 27°C	85°F 29°C	kBtuh	kW	75°F 24°C	80°F 27°C	85°F 29°C	kBtuh	kW	75°F 24°C	80°F 27°C	85°F 29°C	kBtuh	kW	75°F 24°C	80°F 27°C	85°F 29°C
63°F (17°C)	6400	3020	190.9	55.9	9.3	0.61	0.78	0.95	183.3	53.7	10.9	0.62	0.81	0.97	174.9	51.3	12.6	0.63	0.83	0.99	165.9	48.6	14.5	0.64	0.86	0.99
	8000	3780	200.7	58.8	9.4	0.68	0.88	1.00	192.7	56.5	11.0	0.69	0.91	1.00	183.9	53.9	12.6	0.72	0.94	1.00	174.6	51.2	14.6	0.74	0.96	1.00
	9600	4530	209.0	61.3	9.6	0.75	0.96	1.00	200.8	58.9	11.1	0.77	0.97	1.00	192.3	56.4	12.8	0.80	0.99	1.00	183.3	53.7	14.7	0.82	1.00	1.00
67°F (19°C)	6400	3020	206.1	60.4	9.5	0.43	0.58	0.75	197.6	57.9	11.0	0.43	0.59	0.76	188.6	55.3	12.7	0.44	0.60	0.78	178.8	52.4	14.7	0.44	0.62	0.81
	8000	3780	214.7	62.9	9.7	0.47	0.65	0.85	205.7	60.3	11.1	0.48	0.67	0.87	196.1	57.5	12.8	0.48	0.68	0.90	185.6	54.4	14.8	0.50	0.71	0.92
	9600	4530	221.0	64.8	9.7	0.51	0.72	0.92	211.6	62.0	11.2	0.52	0.75	0.95	201.5	59.1	12.9	0.53	0.77	0.97	190.6	55.9	14.9	0.54	0.80	0.99
71°F (22°C)	6400	3020	223.2	65.4	9.7	0.26	0.41	0.56	213.9	62.7	11.3	0.26	0.42	0.57	204.2	59.8	12.9	0.27	0.42	0.58	193.4	56.7	14.9	0.26	0.43	0.59
	8000	3780	231.5	67.8	9.8	0.28	0.45	0.63	221.7	65.0	11.3	0.29	0.46	0.65	211.1	61.9	13.1	0.29	0.47	0.66	199.9	58.6	15.1	0.28	0.48	0.68
	9600	4530	237.2	69.5	9.9	0.31	0.51	0.70	226.7	66.4	11.4	0.31	0.52	0.73	215.7	63.2	13.2	0.30	0.53	0.75	204.3	59.9	15.2	0.31	0.55	0.77

25 TON HIGH EFFICIENCY (R-22) COOLING CAPACITY with HUMIDITROL ON TWO COMPRESSORS OPERATING LGC300S2

Entering Wet Bulb Temperature	Total Air Volume		Outdoor Air Temperature Entering Outdoor Coil																							
			65°F (18°C)						75°F (24°C)						85°F (29°C)						95°F (35°C)					
			Total Cooling Capacity		Comp Motor kW Input	Sensible To Total Ratio (S/T)			Total Cooling Capacity		Comp Motor kW Input	Sensible To Total Ratio (S/T)			Total Cooling Capacity		Comp Motor kW Input	Sensible To Total Ratio (S/T)			Total Cooling Capacity		Comp Motor kW Input	Sensible To Total Ratio (S/T)		
						Dry Bulb						Dry Bulb						Dry Bulb						Dry Bulb		
cfm	L/s	kBtuh	kW	75°F 24°C	80°F 27°C	85°F 29°C	kBtuh	kW	75°F 24°C	80°F 27°C	85°F 29°C	kBtuh	kW	75°F 24°C	80°F 27°C	85°F 29°C	kBtuh	kW	75°F 24°C	80°F 27°C	85°F 29°C	kBtuh	kW	75°F 24°C	80°F 27°C	85°F 29°C
63°F (17°C)	8000	3775	77.0	22.5	8.34	.25	.55	.88	62.6	18.3	9.01	.10	.49	.88	45.0	13.2	9.59	-.18	.38	.91	27.0	7.9	10.37	-.85	-.10	.95
	10000	4720	82.6	24.2	8.46	.36	.74	1.00	68.0	19.9	9.14	.27	.74	1.00	50.2	14.7	9.71	.10	.71	1.00	32.0	9.4	10.47	-.27	.69	1.00
	12000	5665	87.2	25.5	8.56	.51	.91	1.00	72.4	21.2	9.24	.45	.91	1.00	54.6	16.0	9.82	.34	.95	1.00	36.6	10.7	10.60	.13	1.00	1.00
67°F (19°C)	8000	3775	99.0	29.0	8.52	.17	.35	.55	90.2	26.4	9.20	.12	.30	.56	70.0	20.5	9.78	-.08	.15	.47	50.8	14.9	10.54	-.43	-.10	.38
	10000	4720	103.8	30.4	8.64	.22	.42	.72	94.8	27.8	9.32	.18	.40	.73	74.4	21.8	9.89	0	.30	.71	54.8	16.0	10.65	-.29	.14	.71
	12000	5665	107.2	31.4	8.74	.27	.53	.86	98.0	28.7	9.42	.24	.52	.89	77.6	22.7	9.96	.10	.46	.90	57.8	16.9	10.74	-.17	.38	.92
71°F (22°C)	8000	3775	138.8	40.6	8.76	.23	.35	.47	122.6	35.9	9.46	.15	.30	.43	102.4	30.0	10.00	.02	.19	.35	82.6	24.2	10.78	-.16	.05	.25
	10000	4720	143.4	42.0	8.88	.24	.39	.53	127.2	37.2	9.55	.17	.34	.50	106.4	31.2	10.11	.04	.24	.44	86.4	25.3	10.88	-.12	.12	.37
	12000	5665	146.6	42.9	8.96	.26	.43	.60	130.0	38.1	9.65	.19	.39	.59	109.2	32.0	10.19	.08	.31	.56	89.2	26.1	10.95	-.08	.20	.52

25 TON HIGH EFFICIENCY (R-22) COOLING CAPACITY WITH HUMIDITROL ON ALL COMPRESSORS OPERATING LGC300S2

Entering Wet Bulb Temperature	Total Air Volume		Outdoor Air Temperature Entering Outdoor Coil																							
			65°F (18°C)						75°F (24°C)						85°F (29°C)						95°F (35°C)					
			Total Cooling Capacity		Comp Motor kW Input	Sensible To Total Ratio (S/T)			Total Cooling Capacity		Comp Motor kW Input	Sensible To Total Ratio (S/T)			Total Cooling Capacity		Comp Motor kW Input	Sensible To Total Ratio (S/T)			Total Cooling Capacity		Comp Motor kW Input	Sensible To Total Ratio (S/T)		
						Dry Bulb						Dry Bulb						Dry Bulb						Dry Bulb		
cfm	L/s	kBtuh	kW	75°F 24°C	80°F 27°C	85°F 29°C	kBtuh	kW	75°F 24°C	80°F 27°C	85°F 29°C	kBtuh	kW	75°F 24°C	80°F 27°C	85°F 29°C	kBtuh	kW	75°F 24°C	80°F 27°C	85°F 29°C	kBtuh	kW	75°F 24°C	80°F 27°C	85°F 29°C
63°F (17°C)	8000	3775	238.3	69.8	16.78	.58	.78	.97	219.1	64.2	18.42	.57	.79	.99	196.5	57.3	20.11	.55	.79	1.00	173.1	50.7	22.16	.53	.81	1.00
	10000	4720	249.9	73.2	17.03	.65	.88	1.00	230.4	67.5	18.69	.66	.91	1.00	207.4	60.7	20.35	.65	.93	1.00	183.7	53.8	22.38	.63	.95	1.00
	12000	5665	259.5	76.0	17.23	.73	.97	1.00	239.6	70.2	18.89	.74	1.00	1.00	216.6	63.4	20.58	.74	1.00	1.00	193.3	56.6	22.64	.75	1.00	1.00
67°F (19°C)	8000	3775	269.8	79.0	17.16	.44	.59	.74	256.0	75.0	18.81	.43	.59	.75	230.4	67.5	20.50	.40	.57	.76	205.4	60.1	22.53	.35	.55	.77
	10000	4720	279.9	82.0	17.40	.48	.65	.85	265.5	77.7	19.05	.47	.65	.86	239.4	70.1	20.74	.44	.64	.88	213.9	62.6	22.76	.41	.64	.90
	12000	5665	287.0	84.0	17.59	.52	.72	.94	272.3	79.7	19.24	.51	.74	.96	246.1	72.1	20.89	.49	.74	.99	220.2	64.5	22.94	.46	.74	1.00
71°F (22°C)	8000	3775	320.3	93.8	17.65	.36	.48	.60	298.7	87.5	19.32	.33	.47	.59	272.8	79.9	20.97	.29	.44	.58	246.9	72.3	23.03	.25	.41	.56
	10000	4720	330.0	96.6	17.89	.37	.51	.66	308.2	90.2	19.52	.34</														

HUMIDITROL® REHEAT OPTION RATINGS

25 TON STD EFFICIENCY (R-410A) COOLING CAPACITY with HUMIDITROL ON - TWO COMPRESSOR OPERATING LGC300S4

Entering Wet Bulb Temperature	Total Air Volume		Outdoor Air Temperature Entering Outdoor Coil																							
			65°F (18°C)						75°F (24°C)						85°F (29°C)						95°F (35°C)					
			Total Cooling Capacity		Comp Motor kW Input	Sensible To Total Ratio (S/T)			Total Cooling Capacity		Comp Motor kW Input	Sensible To Total Ratio (S/T)			Total Cooling Capacity		Comp Motor kW Input	Sensible To Total Ratio (S/T)			Total Cooling Capacity		Comp Motor kW Input	Sensible To Total Ratio (S/T)		
						Dry Bulb						Dry Bulb						Dry Bulb						Dry Bulb		
cfm	L/s	kBtuh	kW	75°F 24°C	80°F 27°C	85°F 29°C	kBtuh	kW	Input	75°F 24°C	80°F 27°C	85°F 29°C	kBtuh	kW	Input	75°F 24°C	80°F 27°C	85°F 29°C	kBtuh	kW	Input	75°F 24°C	80°F 27°C	85°F 29°C		
63°F (17°C)	8000	3780	101.2	29.7	8.4	0.39	0.64	0.91	88.1	25.8	9.0	0.32	0.63	0.93	67.9	19.9	9.6	0.16	0.59	0.97	49.3	14.4	10.6	0.00	0.53	1.00
	10000	4720	103.9	30.4	8.5	0.45	0.79	1.00	89.9	26.4	9.2	0.41	0.81	1.00	73.5	21.5	9.7	0.35	0.83	1.00	54.1	15.9	10.7	0.20	0.84	1.00
	12000	5660	105.8	31.0	8.6	0.56	0.92	1.00	93.7	27.5	9.3	0.55	0.95	1.00	76.7	22.5	9.8	0.52	0.97	1.00	61.7	18.1	10.8	0.49	1.00	1.00
67°F (19°C)	8000	3780	135.2	39.6	8.5	0.39	0.51	0.68	118.4	34.7	9.2	0.32	0.46	0.66	95.0	27.8	9.7	0.18	0.35	0.62	80.2	23.5	10.7	0.07	0.29	0.62
	10000	4720	137.3	40.2	8.6	0.41	0.56	0.79	121.2	35.5	9.3	0.35	0.53	0.80	98.3	28.8	9.8	0.22	0.45	0.80	84.4	24.7	10.8	0.15	0.44	0.84
	12000	5660	139.4	40.9	8.7	0.43	0.63	0.90	122.7	36.0	9.4	0.38	0.62	0.92	101.9	29.9	9.9	0.29	0.59	0.95	87.3	25.6	10.9	0.22	0.59	0.98
71°F (22°C)	8000	3780	152.4	44.7	8.7	0.30	0.40	0.52	151.5	44.4	9.4	0.32	0.44	0.55	140.3	41.1	9.9	0.30	0.42	0.54	117.2	34.3	11.0	0.19	0.34	0.48
	10000	4720	169.7	49.7	8.8	0.37	0.49	0.62	153.9	45.1	9.5	0.32	0.46	0.60	143.3	42.0	10.1	0.31	0.45	0.60	122.6	35.9	11.0	0.23	0.39	0.57
	12000	5660	173.6	50.9	8.9	0.38	0.52	0.67	155.0	45.4	9.6	0.33	0.49	0.67	146.7	43.0	10.1	0.33	0.49	0.69	126.6	37.1	11.1	0.25	0.45	0.69

25 TON STD EFFICIENCY (R-410A) COOLING CAPACITY with HUMIDITROL ON - ALL COMPRESSOR OPERATING LGC300S4

Entering Wet Bulb Temperature	Total Air Volume		Outdoor Air Temperature Entering Outdoor Coil																							
			65°F (18°C)						75°F (24°C)						85°F (29°C)						95°F (35°C)					
			Total Cooling Capacity		Comp Motor kW Input	Sensible To Total Ratio (S/T)			Total Cooling Capacity		Comp Motor kW Input	Sensible To Total Ratio (S/T)			Total Cooling Capacity		Comp Motor kW Input	Sensible To Total Ratio (S/T)			Total Cooling Capacity		Comp Motor kW Input	Sensible To Total Ratio (S/T)		
						Dry Bulb						Dry Bulb						Dry Bulb						Dry Bulb		
cfm	L/s	kBtuh	kW	75°F 24°C	80°F 27°C	85°F 29°C	kBtuh	kW	Input	75°F 24°C	80°F 27°C	85°F 29°C	kBtuh	kW	Input	75°F 24°C	80°F 27°C	85°F 29°C	kBtuh	kW	Input	75°F 24°C	80°F 27°C	85°F 29°C		
63°F (17°C)	8000	3780	235.6	69.1	20.8	0.61	0.80	0.98	217.5	63.7	23.1	0.60	0.82	0.98	199.8	58.6	25.5	0.59	0.83	0.99	178.6	52.3	28.2	0.58	0.85	1.00
	10000	4720	246.6	72.3	21.0	0.68	0.92	1.00	229.0	67.1	23.3	0.68	0.94	1.00	210.2	61.6	25.8	0.69	0.96	1.00	189.3	55.5	28.5	0.69	0.97	1.00
	12000	5660	255.7	74.9	21.3	0.76	0.99	1.00	238.1	69.8	23.6	0.77	0.99	1.00	219.6	64.4	26.0	0.78	0.99	1.00	198.3	58.1	28.8	0.80	1.00	1.00
67°F (19°C)	8000	3780	275.0	80.6	21.2	0.48	0.63	0.78	265.3	77.8	23.4	0.49	0.64	0.81	233.3	68.4	25.9	0.44	0.61	0.81	214.5	62.9	28.6	0.43	0.61	0.82
	10000	4720	284.9	83.5	21.5	0.52	0.69	0.89	274.7	80.5	23.6	0.53	0.71	0.91	242.0	70.9	26.1	0.49	0.70	0.93	222.9	65.3	28.9	0.48	0.71	0.95
	12000	5660	292.2	85.6	21.7	0.56	0.76	0.98	281.9	82.6	23.8	0.57	0.79	0.99	248.5	72.8	26.3	0.53	0.79	0.99	229.6	67.3	29.1	0.53	0.81	0.99
71°F (22°C)	8000	3780	317.3	93.0	22.0	0.39	0.51	0.64	312.6	91.6	24.1	0.40	0.53	0.66	284.7	83.4	26.6	0.37	0.51	0.65	259.3	76.0	29.6	0.34	0.48	0.64
	10000	4720	327.0	95.8	22.2	0.40	0.55	0.70	321.7	94.3	24.3	0.42	0.58	0.73	293.2	85.9	26.8	0.39	0.56	0.72	267.4	78.4	29.8	0.36	0.54	0.72
	12000	5660	333.3	97.7	22.4	0.41	0.59	0.76	327.7	96.0	24.5	0.44	0.61	0.79	298.8	87.6	27.0	0.40	0.60	0.80	272.6	79.9	30.0	0.38	0.59	0.81

FACTORY INSTALLED BELT DRIVE KIT SPECIFICATIONS

Model No.	Motor Efficiency	Nominal hp	Maximum hp	Nominal kW	Maximum kW	Drive Kit Number	RPM Range
156H	Standard or High	2 hp	2.3	1.5	1.7	A	535 - 725
156H thru 210	Standard	3 hp	3.45	2.2	2.6	A 1	535 - 725 685 - 865
	High	3 hp	3.45	2.2	2.6	2	685 - 865
156H thru 300S	Standard or High	5 hp	5.75	3.7	4.3	2	685 - 865
						3	850 - 1045
						4	945 - 1185
180 thru 300S	Standard or High	7.5 hp	8.63	5.6	6.4	5	945 - 1185
						6	1045 - 1285
						7	850 - 1045
240 thru 300S	Standard or High	10 hp	11.5	7.5	8.6	6	1045 - 1285
						8	1135 - 1365

**BLOWER TABLE INCLUDES RESISTANCE FOR BASE UNIT WITH STANDARD GAS HEAT, WET INDOOR COIL & AIR FILTERS IN PLACE.
FOR ALL UNITS ADD:**

- 1 - Any factory installed options air resistance (high gas heat, economizer, etc.). See table below
 - 2 - Any field installed accessories air resistance (duct resistance, diffuser, etc.). See page 36
- Then determine from table the blower motor output and drive required.

0.30 to 1.40 in. w.g.

LGC156

Air Volume cfm	External Static (in. w.g.)																								
	0.30		0.40		0.50		0.60		0.70		0.80		0.90		1.00		1.10		1.20		1.30		1.40		
	RPM	BHP	RPM	BHP	RPM	BHP	RPM	BHP	RPM	BHP	RPM	BHP	RPM	BHP	RPM	BHP	RPM	BHP	RPM	BHP	RPM	BHP	RPM	BHP	RPM
	Low Static - 2 HP						Standard Static - 3 HP						Standard Static - 5 HP												
4160	551	0.90	596	1.04	641	1.18	681	1.33	720	1.48	755	1.64	790	1.80	822	1.95	855	2.11	885	2.26	915	2.41	942	2.57	
4400	561	0.97	606	1.14	651	1.30	689	1.45	727	1.60	762	1.77	797	1.94	830	2.11	862	2.28	892	2.43	922	2.58	950	2.75	
4800	577	1.13	620	1.31	662	1.48	702	1.66	742	1.83	777	2.01	811	2.18	842	2.36	872	2.54	902	2.72	932	2.89	960	3.07	
5200	593	1.33	636	1.51	678	1.68	716	1.88	754	2.07	789	2.27	823	2.46	856	2.66	888	2.86	916	3.04	944	3.21	972	3.41	
5600	609	1.51	652	1.71	694	1.91	732	2.12	769	2.33	803	2.53	837	2.73	868	2.93	899	3.13	928	3.33	957	3.53	985	3.74	
6000	630	1.75	670	1.95	710	2.15	748	2.38	785	2.60	818	2.83	850	3.05	880	3.25	910	3.45	940	3.68	970	3.90	998	4.13	
6240	640	1.89	680	2.12	720	2.34	757	2.57	795	2.79	827	3.02	860	3.24	890	3.47	920	3.69	947	3.92	975	4.14	1002	4.37	

1.50 to 2.50 in. w.g.

LGC156

Air Volume cfm	External Static (in. w.g.)																					
	1.50		1.60		1.70		1.80		1.90		2.00		2.10		2.20		2.30		2.40		2.50	
	RPM	BHP	RPM	BHP	RPM	BHP	RPM	BHP	RPM	BHP	RPM	BHP	RPM	BHP	RPM	BHP	RPM	BHP	RPM	BHP	RPM	BHP
	High Static - 5 HP										Field Furnished											
4160	970	2.73	997	2.88	1023	3.03	1048	3.20	1073	3.38	1097	3.54	1120	3.71	1142	3.86	1165	4.01	1187	4.17	1208	4.33
4400	977	2.92	1003	3.07	1028	3.22	1053	3.40	1078	3.57	1103	3.76	1127	3.95	1150	4.10	1172	4.25	1193	4.42	1213	4.59
4800	987	3.24	1014	3.42	1041	3.60	1064	3.78	1087	3.95	1112	4.13	1136	4.30	1159	4.50	1181	4.70	1204	4.88	1226	5.06
5200	999	3.60	1024	3.78	1049	3.96	1074	4.16	1099	4.35	1124	4.55	1148	4.74	1171	4.94	1193	5.14	1214	5.34	1234	5.54
5600	1012	3.95	1037	4.15	1062	4.35	1087	4.57	1112	4.80	1135	5.00	1157	5.2	1180	5.41	1202	5.62	1223	5.83	1244	6.04
6000	1025	4.35	1050	4.58	1075	4.80	1098	5.00	1120	5.20	1145	5.43	1170	5.65	1193	5.88	1215	6.10	1235	6.33	1255	6.55
6240	1030	4.59	1055	4.82	1080	5.04	1105	5.26	1130	5.49	1152	5.71	1175	5.94	1197	6.19	1220	6.44	1242	6.66	1265	6.89

AIR RESISTANCE (in. w.g.) - Factory Installed Options

Air Volume - cfm	Gas Heat Exchanger		Economizer	Horizontal Roof Curb	Filters	
	Med. Heat	High Heat			MERV 11	MERV 15
4160	0.02	---	---	0.07	0.01	0.02
4400	0.02	0.04	---	0.07	0.01	0.02
4800	0.03	0.05	---	0.08	0.01	0.02
5000	0.04	0.06	---	0.08	0.01	0.02
5600	0.04	0.07	---	0.10	0.02	0.02
6000	0.05	0.08	---	0.11	0.02	0.03
6240	0.05	0.09	0.01	0.12	0.02	0.03

BLOWER DATA

15 TON

BLOWER TABLE INCLUDES RESISTANCE FOR BASE UNIT WITH STANDARD GAS HEAT, WET INDOOR COIL & AIR FILTERS IN PLACE.

FOR ALL UNITS ADD:

1 - Any factory installed options air resistance (high gas heat, economizer, etc.). See table below

2 - Any field installed accessories air resistance (duct resistance, diffuser, etc.). See page 36

Then determine from table the blower motor output and drive required.

0.30 to 1.40 in. w.g.

LGC180

Air Volume cfm	External Static (in. w.g.)																								
	0.30		0.40		0.50		0.60		0.70		0.80		0.90		1.00		1.10		1.20		1.30		1.40		
	RPM	BHP	RPM	BHP	RPM	BHP	RPM	BHP	RPM	BHP	RPM	BHP	RPM	BHP	RPM	BHP	RPM	BHP	RPM	BHP	RPM	BHP	RPM	BHP	RPM
	Low Static - 3 HP						Standard Static - 3 HP						Standard Static - 5 HP												
4800	577	1.13	620	1.31	662	1.48	702	1.66	742	1.83	777	2.01	811	2.18	842	2.36	872	2.54	902	2.72	932	2.89	960	3.07	
5000	585	1.25	628	1.43	670	1.60	710	1.78	750	1.95	783	2.13	815	2.30	848	2.50	880	2.70	910	2.88	940	3.05	968	3.23	
5500	605	1.45	648	1.65	690	1.85	728	2.05	765	2.25	800	2.45	835	2.65	865	2.85	895	3.05	925	3.25	955	3.45	983	3.65	
6000	630	1.75	670	1.95	710	2.15	748	2.38	785	2.60	818	2.83	850	3.05	880	3.25	910	3.45	940	3.68	970	3.90	998	4.13	
6500	650	2.05	690	2.28	730	2.50	768	2.75	805	3.00	838	3.23	870	3.45	900	3.70	930	3.95	958	4.18	985	4.40	1013	4.63	
7000	675	2.35	715	2.63	755	2.90	790	3.15	825	3.40	858	3.68	890	3.95	920	4.20	950	4.45	978	4.70	1005	4.95	1030	5.18	
7200	687	2.55	725	2.81	763	3.06	798	3.33	833	3.60	866	3.86	898	4.11	926	4.36	954	4.61	984	4.90	1013	5.19	1038	5.44	

1.50 to 2.50 in. w.g.

LGC180

Air Volume cfm	External Static (in. w.g.)																						
	1.50		1.60		1.70		1.80		1.90		2.00		2.10		2.20		2.30		2.40		2.50		
	RPM	BHP	RPM	BHP	RPM	BHP	RPM	BHP	RPM	BHP	RPM	BHP	RPM	BHP	RPM	BHP	RPM	BHP	RPM	BHP	RPM	BHP	RPM
	High Static - 5 HP										High Static - 7.5 HP												
4800	987	3.24	1014	3.42	1041	3.60	1064	3.78	1087	3.95	1112	4.13	1136	4.30	1159	4.50	1181	4.70	1204	4.88	1226	5.06	
5000	995	3.40	1020	3.60	1045	3.80	1070	3.98	1095	4.15	1118	4.33	1140	4.50	1163	4.70	1185	4.90	1208	5.10	1230	5.30	
5500	1010	3.85	1035	4.05	1060	4.25	1085	4.48	1110	4.70	1133	4.90	1155	5.10	1178	5.30	1200	5.50	1220	5.70	1240	5.90	
6000	1025	4.35	1050	4.58	1075	4.80	1098	5.00	1120	5.20	1145	5.43	1170	5.65	1193	5.88	1215	6.10	1235	6.33	1255	6.55	
6500	1040	4.85	1065	5.10	1090	5.35	1115	5.60	1140	5.85	1163	6.08	1185	6.30	1205	6.53	1225	6.75	1248	7.00	1270	7.25	
7000	1055	5.40	1080	5.68	1105	5.95	1130	6.20	1155	6.45	1178	6.70	1200	6.95	1220	7.20	1240	7.45	1263	7.73	1285	8.00	
7200	1063	5.68	1088	5.94	1113	6.19	1136	6.44	1159	6.69	1182	6.96	1204	7.23	1226	7.50	1248	7.77	1269	8.03	1289	8.28	

NOTE - *italics* - field furnished.

AIR RESISTANCE (in. w.g.) - Factory Installed Options

Air Volume - cfm	Gas Heat Exchanger		Economizer	Horizontal Roof Curb	Filters	
	Med. Heat	High Heat			MERV 11	MERV 15
4800	0.03	0.05	---	0.08	0.01	0.02
5000	0.04	0.06	---	0.08	0.01	0.02
5500	0.04	0.07	---	0.10	0.02	0.02
6000	0.05	0.08	---	0.11	0.02	0.03
6500	0.05	0.09	0.02	0.13	0.02	0.03
7000	0.06	0.10	0.04	0.15	0.03	0.03
7200	0.07	0.11	0.05	0.16	0.03	0.03

BLOWER DATA

17.5 TON

BLOWER TABLE INCLUDES RESISTANCE FOR BASE UNIT WITH STANDARD GAS HEAT, WET INDOOR COIL & AIR FILTERS IN PLACE.

FOR ALL UNITS ADD:

1 - Any factory installed options air resistance (high gas heat, economizer, etc.). See table below

2 - Any field installed accessories air resistance (duct resistance, diffuser, etc.). See page 36

Then determine from table the blower motor output and drive required.

0.20 to 1.20 in. w.g.

LGC210

Air Volume cfm	External Static (in. w.g.)																							
	0.20		0.30		0.40		0.50		0.60		0.70		0.80		0.90		1.00		1.10		1.20			
	RPM	BHP	RPM	BHP	RPM	BHP	RPM	BHP	RPM	BHP	RPM	BHP	RPM	BHP	RPM	BHP	RPM	BHP	RPM	BHP	RPM	BHP		
	Low Static - 3 HP												Standard Static - 5 HP											
5600	609	1.51	652	1.71	694	1.91	732	2.12	769	2.33	803	2.53	837	2.73	868	2.93	899	3.13	928	3.33	957	3.53		
6000	630	1.75	670	1.95	710	2.15	748	2.38	785	2.60	818	2.83	850	3.05	880	3.25	910	3.45	940	3.68	970	3.90		
6500	650	2.05	690	2.28	730	2.50	768	2.75	805	3.00	838	3.23	870	3.45	900	3.70	930	3.95	958	4.18	985	4.40		
7000	675	2.35	715	2.63	755	2.90	790	3.15	825	3.40	858	3.68	890	3.95	920	4.20	950	4.45	978	4.70	1005	4.95		
7500	700	2.75	738	3.03	775	3.30	810	3.58	845	3.85	878	4.15	910	4.45	938	4.70	965	4.95	993	5.23	1020	5.50		
8000	725	3.20	763	3.50	800	3.80	833	4.08	865	4.35	898	4.65	930	4.95	958	5.23	985	5.50	1013	5.80	1040	6.10		
8400	746	3.55	783	3.87	819	4.18	853	4.49	886	4.80	916	5.12	946	5.43	974	5.73	1001	6.03	1029	6.35	1056	6.66		

1.30 to 2.40 in. w.g.

LGC210

Air Volume cfm	External Static (in. w.g.)																							
	1.30		1.40		1.50		1.60		1.70		1.80		1.90		2.00		2.10		2.20		2.30		2.40	
	RPM	BHP	RPM	BHP	RPM	BHP	RPM	BHP	RPM	BHP	RPM	BHP	RPM	BHP	RPM	BHP	RPM	BHP	RPM	BHP	RPM	BHP	RPM	BHP
	Standard Static - 5 HP						High Static - 7.5 HP																	
5600	985	3.74	1012	3.95	1037	4.15	1062	4.35	1087	4.58	1112	4.80	1135	5.00	1157	5.20	1180	5.41	1202	5.62	1223	5.83	1244	6.04
6000	998	4.13	1025	4.35	1050	4.58	1075	4.80	1098	5.00	1120	5.20	1145	5.43	1170	5.65	1193	5.88	1215	6.10	1235	6.33	1255	6.55
6500	1013	4.63	1040	4.85	1065	5.10	1090	5.35	1115	5.60	1140	5.85	1163	6.08	1185	6.30	1205	6.53	1225	6.75	1248	7.00	1270	7.25
7000	1030	5.18	1055	5.40	1080	5.68	1105	5.95	1130	6.20	1155	6.45	1178	6.70	1200	6.95	1220	7.20	1240	7.45	1263	7.73	1285	8.00
7500	1048	5.78	1075	6.05	1100	6.33	1125	6.60	1148	6.88	1170	7.15	1193	7.40	1215	7.65	1238	7.95	1260	8.25	1280	8.50	1300	8.75
8000	1065	6.40	1090	6.70	1115	6.98	1140	7.25	1163	7.55	1185	7.85	1208	8.13	1230	8.40	1253	8.70	1275	9.00	1295	9.30	1315	9.60
8400	1081	6.96	1106	7.26	1131	7.58	1156	7.89	1179	8.19	1201	8.49	1224	8.79	1246	9.09	1266	9.38	1286	9.67	1307	9.98	1328	10.29

NOTE - *italics* - field furnished.

AIR RESISTANCE (in. w.g.) - Factory or Field Installed Options

Air Volume - cfm	Gas Heat Exchanger		Economizer	Horizontal Roof Curb	Filters	
	Med. Heat	High Heat			MERV 11	MERV 15
5600	0.04	0.07	---	0.10	0.02	0.02
6000	0.05	0.08	---	0.11	0.02	0.03
6500	0.05	0.09	0.02	0.13	0.02	0.03
7000	0.06	0.10	0.04	0.15	0.03	0.03
7500	0.07	0.11	0.06	0.17	0.03	0.03
8000	0.08	0.13	0.09	0.19	0.04	0.03
8400	0.08	0.14	0.11	0.21	0.04	0.03

BLOWER DATA

20 TON

BLOWER TABLE INCLUDES RESISTANCE FOR BASE UNIT WITH STANDARD GAS HEAT, WET INDOOR COIL & AIR FILTERS IN PLACE.

FOR ALL UNITS ADD:

1 - Any factory installed options air resistance (high gas heat, economizer, etc.). See table below

2 - Any field installed accessories air resistance (duct resistance, diffuser, etc.). See page 36

Then determine from table the blower motor output and drive required.

0.20 to 1.20 in. w.g.

LGA/LGC240

Air Volume cfm	External Static (in. w.g.)																					
	.20		0.30		0.40		0.50		0.60		0.70		0.80		0.90		1.00		1.10		1.20	
	RPM	BHP	RPM	BHP	RPM	BHP	RPM	BHP	RPM	BHP	RPM	BHP	RPM	BHP	RPM	BHP	RPM	BHP	RPM	BHP	RPM	BHP
	Field		Low Static - 5 HP						Standard Static - 7.5 HP													
6400	648	1.99	688	2.22	727	2.46	764	2.69	801	2.92	834	3.15	866	3.39	896	3.62	926	3.85	954	4.08	981	4.30
7000	675	2.35	715	2.63	755	2.90	790	3.15	825	3.40	858	3.68	890	3.95	920	4.20	950	4.45	978	4.70	1005	4.95
7500	700	2.75	738	3.03	775	3.30	810	3.58	845	3.85	878	4.15	910	4.45	938	4.70	965	4.95	993	5.23	1020	5.50
8000	725	3.20	763	3.50	800	3.80	833	4.08	865	4.35	898	4.65	930	4.95	958	5.23	985	5.50	1013	5.80	1040	6.10
8500	750	3.65	788	3.98	825	4.30	858	4.60	890	4.90	920	5.23	950	5.55	978	5.85	1005	6.15	1033	6.48	1060	6.80
9000	780	4.20	815	4.53	850	4.85	880	5.18	910	5.50	940	5.83	970	6.15	998	6.48	1025	6.80	1053	7.15	1080	7.50
9600	811	4.87	845	5.22	879	5.57	910	5.94	941	6.31	970	6.67	999	7.02	1027	7.38	1054	7.74	1079	8.08	1104	8.41

NOTE - *italics* - field furnished.

1.30 to 2.40 in. w.g.

LGA/LGC240

Air Volume cfm	External Static (in. w.g.)																							
	1.30		1.40		1.50		1.60		1.70		1.80		1.90		2.00		2.10		2.20		2.30		2.40	
	RPM	BHP	RPM	BHP	RPM	BHP	RPM	BHP	RPM	BHP	RPM	BHP	RPM	BHP	RPM	BHP	RPM	BHP	RPM	BHP	RPM	BHP	RPM	BHP
	Std. Static - 7.5 HP				High Static - 10 HP																			
6400	1008	4.53	1035	4.75	1060	4.98	1085	5.22	1110	5.45	1135	5.68	1157	5.91	1180	6.15	1202	6.40	1225	6.65	1246	6.88	1268	7.11
7000	1030	5.18	1055	5.40	1080	5.68	1105	5.95	1130	6.20	1155	6.45	1178	6.70	1200	6.95	1220	7.20	1240	7.45	1263	7.73	1285	8.00
7500	1048	5.78	1075	6.05	1100	6.33	1125	6.60	1148	6.88	1170	7.15	1193	7.40	1215	7.65	1238	7.95	1260	8.25	1280	8.50	1300	8.75
8000	1065	6.40	1090	6.70	1115	6.98	1140	7.25	1163	7.55	1185	7.85	1208	8.13	1230	8.40	1253	8.70	1275	9.00	1295	9.30	1315	9.60
8500	1085	7.10	1110	7.40	1135	7.73	1160	8.05	1183	8.35	1205	8.65	1228	8.95	1250	9.25	1270	9.55	1290	9.85	1310	10.15	1330	10.45
9000	1105	7.83	1130	8.15	1153	8.45	1175	8.75	1198	9.08	1220	9.40	1243	9.75	1265	10.10	1288	10.45	1310	10.80	1330	11.10	1350	11.40
9600	1129	8.77	1154	9.13	1177	9.46	1199	9.78	1222	10.14	1244	10.50	1267	10.87	1289	11.23	---	---	---	---	---	---		

AIR RESISTANCE (in. w.g.) - Factory or Field Installed Options

Air Volume - cfm	Gas Heat Exchanger		Economizer	Horizontal Roof Curb	Filters	
	Med. Heat	High Heat			MERV 11	MERV 15
6400	0.05	0.09	0.02	0.13	0.02	0.03
7000	0.06	0.10	0.04	0.15	0.03	0.03
7500	0.07	0.11	0.06	0.17	0.03	0.03
8000	0.08	0.13	0.09	0.19	0.04	0.03
8500	0.08	0.14	0.11	0.21	0.04	0.03
9000	0.10	0.16	0.14	0.24	0.04	0.04
9600	0.11	0.18	0.16	0.26	0.05	0.04

BLOWER DATA

STANDARD 25 TON

BLOWER TABLE INCLUDES RESISTANCE FOR BASE UNIT WITH STANDARD GAS HEAT, WET INDOOR COIL & AIR FILTERS IN PLACE.

FOR ALL UNITS ADD:

1 - Any factory installed options air resistance (high gas heat, economizer, etc.). See table below

2 - Any field installed accessories air resistance (duct resistance, diffuser, etc.). See page 36

Then determine from table the blower motor output and drive required.

0.00 to 1.00 in. w.g.

LGC300S

Air Volume cfm	External Static (in. w.g.)																					
	0.00		0.10		0.20		0.30		0.40		0.50		0.60		0.70		0.80		0.90		1.00	
	RPM	BHP	RPM	BHP	RPM	BHP	RPM	BHP	RPM	BHP	RPM	BHP	RPM	BHP	RPM	BHP	RPM	BHP	RPM	BHP	RPM	BHP
	Low Static - 5 HP						Low Static - 7.5 HP															
8000	725	3.20	763	3.50	800	3.80	833	4.08	865	4.35	898	4.65	930	4.95	958	5.23	985	5.50	1013	5.80	1040	6.10
8500	750	3.65	788	3.98	825	4.30	858	4.60	890	4.90	920	5.23	950	5.55	978	5.85	1005	6.15	1033	6.48	1060	6.80
9250	790	4.45	825	4.80	860	5.15	893	5.50	925	5.85	955	6.20	985	6.55	1013	6.88	1040	7.20	1065	7.53	1090	7.85
10000	835	5.40	868	5.78	900	6.15	930	6.50	960	6.85	988	7.23	1015	7.60	1043	7.98	1070	8.35	1095	8.70	1120	9.05
10750	875	6.40	908	6.83	940	7.25	970	7.65	1000	8.05	1028	8.45	1055	8.85	1080	9.25	1105	9.65	1130	10.05	1155	10.45
11500	915	7.40	948	7.88	980	8.35	1010	8.80	1040	9.25	1068	9.68	1095	10.10	1118	10.53	1140	10.95	1165	11.40	1190	11.85

NOTE - *italics* - field furnished.

1.10 to 2.20 in. w.g.

LGC300S

Air Volume cfm	External Static (in. w.g.)																							
	1.10		1.20		1.30		1.40		1.50		1.60		1.70		1.80		1.90		2.00		2.10		2.20	
	RPM	BHP	RPM	BHP	RPM	BHP	RPM	BHP	RPM	BHP	RPM	BHP	RPM	BHP	RPM	BHP	RPM	BHP	RPM	BHP	RPM	BHP	RPM	BHP
	Standard Static - 10 HP																							
8000	1065	6.40	1090	6.70	1115	6.98	1140	7.25	1163	7.55	1185	7.85	1208	8.13	1230	8.40	1253	8.70	1275	9.00	1295	9.30	1315	9.60
8500	1085	7.10	1110	7.40	1135	7.73	1160	8.05	1183	8.35	1205	8.65	1228	8.95	1250	9.25	1270	9.55	1290	9.85	1310	10.15	1330	10.45
9250	1115	8.20	1140	8.55	1163	8.88	1185	9.20	1208	9.53	1230	9.85	1253	10.20	1275	10.55	1295	10.88	1315	11.20	---	---	---	---
10000	1145	9.43	1170	9.80	1193	10.15	1215	10.50	1238	10.88	1260	11.25	1283	11.62	---	---	---	---	---	---	---	---	---	---
10750	1178	10.83	1200	11.20	1222	11.57	---	---	---	---	---	---	---	---	---	---	---	---	---	---	---	---	---	---
11500	1210	12.23	1230	12.60	---	---	---	---	---	---	---	---	---	---	---	---	---	---	---	---	---	---	---	---

NOTE - *italics* - field furnished.

AIR RESISTANCE (in. w.g.) - Factory or Field Installed Options

Air Volume - cfm	Gas Heat Exchanger		Economizer	Horizontal Roof Curb	Filters	
	Med. Heat	High Heat			MERV 11	MERV 15
8000	0.08	0.13	0.09	0.13	0.04	0.03
8500	0.08	0.14	0.11	0.15	0.04	0.03
9250	0.11	0.17	0.15	0.18	0.05	0.03
10,000	0.11	0.19	0.19	0.21	0.06	0.04

BLOWER DATA

CEILING DIFFUSER AIR RESISTANCE

Air Volume		Step-Down Diffuser												Flush Diffuser			
		RTD11-185						RTD11-275						FD11-185		FD11-275	
		2 Ends Open		1 Side/2 Ends Open		All Ends & Sides Open		2 Ends Open		1 Side/2 Ends Open		All Ends & Sides Open		in. w.g.	Pa	in. w.g.	Pa
cfm	L/s	in. w.g.	Pa	in. w.g.	Pa	in. w.g.	Pa	in. w.g.	Pa	in. w.g.	Pa	in. w.g.	Pa	in. w.g.	Pa		
5000	2360	.51	127	.44	109	.39	97	---	---	---	---	---	---	.27	67	---	---
5200	2455	.56	139	.48	119	.42	104	---	---	---	---	---	---	.30	75	---	---
5400	2550	.61	152	.52	129	.45	112	---	---	---	---	---	---	.33	82	---	---
5600	2645	.66	164	.56	139	.48	119	---	---	---	---	---	---	.36	90	---	---
5800	2735	.71	177	.59	147	.51	127	---	---	---	---	---	---	.39	97	---	---
6000	2830	.76	189	.63	157	.55	137	.36	90	.31	77	.27	67	.42	104	.29	72
6200	2925	.80	199	.68	169	.59	147	---	---	---	---	---	---	.46	114	---	---
6400	3020	.86	214	.72	179	.63	157	---	---	---	---	---	---	.50	124	---	---
6500	3065	---	---	---	---	---	---	.42	104	.36	90	.31	77	---	---	.34	85
6600	3115	.92	229	.77	191	.67	167	---	---	---	---	---	---	.54	134	---	---
6800	3210	.99	246	.83	206	.72	174	---	---	---	---	---	---	.58	144	---	---
7000	3305	1.03	256	.87	216	.76	189	.49	122	.41	102	.36	90	.62	154	.40	99
7200	3400	1.09	271	.92	229	.80	199	---	---	---	---	---	---	.66	164	---	---
7400	3490	1.15	286	.97	241	.84	209	---	---	---	---	---	---	.70	174	---	---
7500	3540	---	---	---	---	---	---	.51	127	.46	114	.41	102	---	---	.45	112
7600	3585	1.20	301	1.02	254	.88	219	---	---	---	---	---	---	.74	184	---	---
8000	3775	---	---	---	---	---	---	.59	147	.49	122	.43	107	---	---	.50	124
8500	4010	---	---	---	---	---	---	.69	172	.58	144	.50	124	---	---	.57	142
9000	4245	---	---	---	---	---	---	.79	196	.67	167	.58	144	---	---	.66	164
9500	4485	---	---	---	---	---	---	.89	221	.75	186	.65	162	---	---	.74	184
10,000	4720	---	---	---	---	---	---	1.00	249	.84	209	.73	182	---	---	.81	201
10,500	4955	---	---	---	---	---	---	1.10	273	.92	229	.80	199	---	---	.89	221
11,000	5190	---	---	---	---	---	---	1.21	301	1.01	251	.88	219	---	---	.96	239

BLOWER DATA

POWER EXHAUST FANS STANDARD STATIC OPERATION

Return Duct Negative Static Pressure		Air Volume	
in. w.g.	Pa	cfm	L/s
0	0	8630	4070
0.05	12	8210	3875
0.10	25	7725	3645
0.15	37	7110	3355
0.20	50	6470	3055
0.25	62	5790	2730
0.30	75	5060	2390
0.35	87	4300	2030
0.40	100	3510	1655
0.45	112	2690	1270
0.50	125	1840	870

CEILING DIFFUSER AIR THROW DATA

Model No.	Air Volume		¹ Effective Throw Range			
	cfm	L/s	Step-Down		Flush	
			ft.	m	ft.	m
156H 180	Diffuser Model		RTD11-185		FD11-185	
	5600	2645	39 - 49	12 - 15	28 - 37	9 - 11
	5800	2740	42 - 51	13 - 16	29 - 38	9 - 12
	6000	2830	44 - 54	13 - 17	40 - 50	12 - 15
	6200	2925	45 - 55	14 - 17	42 - 51	13 - 16
	6400	3020	46 - 55	14 - 17	53 - 52	13 - 16
	6600	3115	57 - 56	14 - 17	45 - 56	14 - 17
210 240 300S	Diffuser Model		RTD11-275		FD11-275	
	7200	3400	33 - 38	10 - 12	26 - 35	8 - 11
	7400	3490	35 - 40	11 - 12	28 - 37	9 - 11
	7600	3585	36 - 41	11 - 13	29 - 38	9 - 12
	7800	3680	38 - 43	11 - 13	40 - 50	12 - 15
	8000	3775	39 - 44	12 - 13	42 - 51	13 - 16
	8200	3870	41 - 46	12 - 14	43 - 52	13 - 16
	8400	3965	43 - 49	13 - 15	44 - 54	13 - 17
	8600	4060	44 - 50	13 - 15	46 - 57	14 - 17
8800	4155	47 - 55	14 - 17	48 - 59	15 - 18	

¹ Throw is the horizontal or vertical distance an airstream travels on leaving the outlet or diffuser before the maximum velocity is reduced to 50 ft. (15 m) per minute. Four sides open.

ELECTRICAL DATA**13 TON****13 TON HIGH EFFICIENCY (R-22)****LGC156H2**

Voltage - 60hz - 3 phase		208/230V			460V			575V		
Compressors (3)	Rated Load Amps (total)	14.7 (44.1)			7.1 (21.3)			5.1 (15.3)		
	Locked Rotor Amps (total)	91 (273)			50 (150)			37 (111)		
Outdoor Fan Motors (4)	Full Load Amps (total)	2.4 (9.6)			1.3 (5.2)			1 (4)		
	Locked Rotor Amps (total)	4.7 (18.8)			2.4 (9.6)			1.9 (7.6)		
Standard Power Exhaust Fans (2)	Horsepower (W)	1/3 (249)			1/3 (249)			1/3 (249)		
	Full Load Amps(total)	2.4 (4.8)			1.3 (2.6)			1 (2)		
	Locked Rotor Amps (total)	4.7 (9.4)			2.4 (4.8)			1.9 (3.8)		
Service Outlet 115V GFI		15 Amps			15 Amps			15 Amps		
Indoor Blower Motor	Horsepower	2	3	5	2	3	5	2	3	5
	Rated Load Amps	7.5	10.6	16.7	3.4	4.8	7.6	2.7	3.9	6.1
	Locked Rotor Amps	46.9	66	105	20.4	26.8	45.6	16.2	23.4	36.6
¹ Maximum Overcurrent Protection	Unit only	70	80	90	35	40	40	25	25	30
	with power exhaust	80	80	90	40	40	45	30	30	35
² Minimum Circuit Ampacity	Unit only	65	68	75	32	34	36	24	25	27
	with power exhaust	70	73	79	35	36	39	26	27	29
Disconnect		84M13		84M14	84M13			84M13		

13 TON HIGH EFFICIENCY (R-410A)**LGC156H4**

Voltage - 60hz - 3 phase		208/230V			460V			575V		
Compressors (3)	Rated Load Amps (total)	17.9 (53.7)			7.9 (23.7)			6.2 (18.6)		
	Locked Rotor Amps (total)	91 (273)			46 (138)			37 (111)		
Outdoor Fan Motors (4)	Full Load Amps (total)	2.4 (9.6)			1.3 (5.2)			1 (4)		
	Locked Rotor Amps (total)	4.7 (18.8)			2.4 (9.6)			1.9 (7.6)		
Standard Power Exhaust Fans (2)	Horsepower (W)	1/3 (249)			1/3 (249)			1/3 (249)		
	Full Load Amps(total)	2.4 (4.8)			1.3 (2.6)			1 (2)		
	Locked Rotor Amps (total)	4.7 (9.4)			2.4 (4.8)			1.9 (3.8)		
Service Outlet 115V GFI		15 Amps			15 Amps			15 Amps		
Indoor Blower Motor	Horsepower	2	3	5	2	3	5	2	3	5
	Rated Load Amps	7.5	10.6	16.7	3.4	4.8	7.6	2.7	3.9	6.1
	Locked Rotor Amps	46.9	66	105	20.4	26.8	45.6	16.2	23.4	36.6
¹ Maximum Overcurrent Protection	Unit only	90	90	100	40	40	45	30	30	35
	with power exhaust	90	100	100	40	45	45	35	35	35
² Minimum Circuit Ampacity	Unit only	76	79	85	35	36	39	27	29	31
	with power exhaust	81	84	90	37	39	42	29	31	33
Disconnect		84M13		84M14	84M13			84M13		

NOTE - Extremes of operating range are plus and minus 10% of line voltage.

¹ HACR type breaker or fuse.² Refer to National or Canadian Electrical Code manual to determine wire, fuse and disconnect size requirements.

ELECTRICAL DATA

15 TON

15 TON STANDARD EFFICIENCY (R-22)

LGC180S2

Voltage - 60hz - 3 phase		208/230V			460V			575V		
Compressors (3)	Rated Load Amps (total)	15.4 (46.2)			7.4 (22.2)			5.9 (17.7)		
	Locked Rotor Amps (total)	124 (372)			59.6 (178.8)			49.4 (148.2)		
Outdoor Fan Motors (4)	Full Load Amps (total)	2.4 (9.6)			1.3 (5.2)			1 (4)		
	Locked Rotor Amps (total)	4.7 (18.8)			2.4 (9.6)			1.9 (7.6)		
Standard Power Exhaust Fans (2)	Horsepower (W)	1/3 (249)			1/3 (249)			1/3 (249)		
	Full Load Amps(total)	2.4 (4.8)			1.3 (2.6)			1 (2)		
	Locked Rotor Amps (total)	4.7 (9.4)			2.4 (4.8)			1.9 (3.8)		
Service Outlet 115V GFI		15 Amps			15 Amps			15 Amps		
Indoor Blower Motor	Horsepower	3	5	7.5	3	5	7.5	3	5	7.5
	Rated Load Amps	10.6	16.7	24.2	4.8	7.6	11	3.9	6.1	9
	Locked Rotor Amps	66	105	152	26.8	45.6	66	23.4	36.6	54
¹ Maximum Overcurrent Protection	Unit only	80	90	110	40	40	50	30	35	40
	with power exhaust	90	90	110	40	45	50	35	35	40
² Minimum Circuit Ampacity	Unit only	71	77	84	35	37	41	28	30	33
	with power exhaust	76	82	89	37	40	43	30	32	35
Disconnect		84M14			84M13			84M13		

15 TON HIGH EFFICIENCY (R-22)

LGC180H2

Voltage - 60hz - 3 phase		208/230V			460V			575V		
Compressors (3)	Rated Load Amps (total)	17.3 (51.9)			9 (27)			7.1 (21.3)		
	Locked Rotor Amps (total)	123 (369)			62 (186)			50 (150)		
Outdoor Fan Motors (4)	Full Load Amps (total)	2.4 (9.6)			1.3 (5.2)			1 (4)		
	Locked Rotor Amps (total)	4.7 (18.8)			2.4 (9.6)			1.9 (7.6)		
Standard Power Exhaust Fans (2)	Horsepower (W)	1/3 (249)			1/3 (249)			1/3 (249)		
	Full Load Amps(total)	2.4 (4.8)			1.3 (2.6)			1 (2)		
	Locked Rotor Amps (total)	4.7 (9.4)			2.4 (4.8)			1.9 (3.8)		
Service Outlet 115V GFI		15 Amps			15 Amps			15 Amps		
Indoor Blower Motor	Horsepower	3	5	7.5	3	5	7.5	3	5	7.5
	Rated Load Amps	10.6	16.7	24.2	4.8	7.6	11	3.9	6.1	9
	Locked Rotor Amps	66	105	152	26.8	45.6	66	23.4	36.6	54
¹ Maximum Overcurrent Protection	Unit only	90	90	110	45	50	50	35	40	45
	with power exhaust	90	100	110	50	50	50	40	40	45
² Minimum Circuit Ampacity	Unit only	77	83	91	40	43	46	31	34	37
	with power exhaust	82	88	95	42	45	49	33	36	39
Disconnect		84M14			84M13			84M13		

15 TON HIGH EFFICIENCY (R-410A)

LGC180H4

Voltage - 60hz - 3 phase		208/230V			460V			575V		
Compressors (3)	Rated Load Amps (total)	15.6 (46.8)			7.8 (23.4)			5.8 (17.4)		
	Locked Rotor Amps (total)	110 (330)			52 (156)			38.9 (116.7)		
Outdoor Fan Motors (4)	Full Load Amps (total)	2.4 (9.6)			1.3 (5.2)			1 (4)		
	Locked Rotor Amps (total)	4.7 (18.8)			2.4 (9.6)			1.9 (7.6)		
Standard Power Exhaust Fans (2)	Horsepower (W)	1/3 (249)			1/3 (249)			1/3 (249)		
	Full Load Amps(total)	2.4 (4.8)			1.3 (2.6)			1 (2)		
	Locked Rotor Amps (total)	4.7 (9.4)			2.4 (4.8)			1.9 (3.8)		
Service Outlet 115V GFI		15 Amps			15 Amps			15 Amps		
Indoor Blower Motor	Horsepower	3	5	7.5	3	5	7.5	3	5	7.5
	Rated Load Amps	10.6	16.7	24.2	4.8	7.6	11	3.9	6.1	9
	Locked Rotor Amps	66	105	152	26.8	45.6	66	23.4	36.6	54
¹ Maximum Overcurrent Protection	Unit only	80	90	110	40	45	50	30	35	40
	with power exhaust	90	90	110	45	45	50	30	35	40
² Minimum Circuit Ampacity	Unit only	71	77	85	36	39	42	27	29	32
	with power exhaust	76	82	90	38	41	45	29	31	34
Disconnect		84M14			84M13			84M13		

NOTE - Extremes of operating range are plus and minus 10% of line voltage.

¹ HACR type breaker or fuse.

² Refer to National or Canadian Electrical Code manual to determine wire, fuse and disconnect size requirements.

ELECTRICAL DATA

17.5 TON

17.5 TON STANDARD EFFICIENCY (R-22)

LGC210S2

Voltage - 60hz - 3 phase		208/230V			460V			575V		
Compressors (4)	Rated Load Amps (total)	14.7 (58.8)			7.1 (28.4)			5.8 (23.2)		
	Locked Rotor Amps (total)	91 (364)			50 (200)			37 (148)		
Outdoor Fan Motors (4)	Full Load Amps (total)	2.4 (9.6)			1.3 (5.2)			1 (4)		
	Locked Rotor Amps (total)	4.7 (18.8)			2.4 (9.6)			1.9 (7.6)		
Standard Power Exhaust Fans (2)	Horsepower (W)	1/3 (249)			1/3 (249)			1/3 (249)		
	Full Load Amps(total)	2.4 (4.8)			1.3 (2.6)			1 (2)		
	Locked Rotor Amps (total)	4.7 (9.4)			2.4 (4.8)			1.9 (3.8)		
Service Outlet 115V GFI		15 Amps			15 Amps			15 Amps		
Indoor Blower Motor	Horsepower	3	5	7.5	3	5	7.5	3	5	7.5
	Rated Load Amps	10.6	16.7	24.2	4.8	7.6	11	3.9	6.1	9
	Locked Rotor Amps	66	105	152	26.8	45.6	66	23.4	36.6	54
¹ Maximum Overcurrent Protection	Unit only	90	100	110	45	50	50	35	40	45
	with power exhaust	100	110	125	45	50	60	40	40	45
² Minimum Circuit Ampacity	Unit only	83	89	97	41	43	47	33	35	38
	with power exhaust	88	94	102	43	46	49	35	37	40
Disconnect		84M14			84M13			84M13		

17.5 TON HIGH EFFICIENCY (R-22)

LGC210H2

Voltage - 60hz - 3 phase		208/230V			460V			575V		
Compressors (4)	Rated Load Amps (total)	14.7 (58.8)			7.1 (28.4)			5.1 (20.4)		
	Locked Rotor Amps (total)	91 (364)			50 (200)			37 (148)		
Outdoor Fan Motors (4)	Full Load Amps (total)	2.4 (9.6)			1.3 (5.2)			1 (4)		
	Locked Rotor Amps (total)	4.7 (18.8)			2.4 (9.6)			1.9 (7.6)		
Standard Power Exhaust Fans (2)	Horsepower (W)	1/3 (249)			1/3 (249)			1/3 (249)		
	Full Load Amps(total)	2.4 (4.8)			1.3 (2.6)			1 (2)		
	Locked Rotor Amps (total)	4.7 (9.4)			2.4 (4.8)			1.9 (3.8)		
Service Outlet 115V GFI		15 Amps			15 Amps			15 Amps		
Indoor Blower Motor	Horsepower	3	5	7.5	3	5	7.5	3	5	7.5
	Rated Load Amps	10.6	16.7	24.2	4.8	7.6	11	3.9	6.1	9
	Locked Rotor Amps	66	105	152	26.8	45.6	66	23.4	36.6	54
¹ Maximum Overcurrent Protection	Unit only	90	100	110	45	50	50	30	35	40
	with power exhaust	100	110	125	45	50	60	35	40	45
² Minimum Circuit Ampacity	Unit only	83	89	97	41	43	47	30	32	35
	with power exhaust	88	94	102	43	46	49	32	34	37
Disconnect		84M14			84M13			84M13		

17.5 TON HIGH EFFICIENCY (R-410A)

LGC210H4

Voltage - 60hz - 3 phase		208/230V			460V			575V		
Compressors (4)	Rated Load Amps (total)	17.9 (71.6)			7.9 (31.6)			6.2 (24.8)		
	Locked Rotor Amps (total)	91 (364)			46 (184)			37 (148)		
Outdoor Fan Motors (4)	Full Load Amps (total)	2.4 (9.6)			1.3 (5.2)			1 (4)		
	Locked Rotor Amps (total)	4.7 (18.8)			2.4 (9.6)			1.9 (7.6)		
Standard Power Exhaust Fans (2)	Horsepower (W)	1/3 (249)			1/3 (249)			1/3 (249)		
	Full Load Amps(total)	2.4 (4.8)			1.3 (2.6)			1 (2)		
	Locked Rotor Amps (total)	4.7 (9.4)			2.4 (4.8)			1.9 (3.8)		
Service Outlet 115V GFI		15 Amps			15 Amps			15 Amps		
Indoor Blower Motor	Horsepower	3	5	7.5	3	5	7.5	3	5	7.5
	Rated Load Amps	10.6	16.7	24.2	4.8	7.6	11	3.9	6.1	9
	Locked Rotor Amps	66	105	152	26.8	45.6	66	23.4	36.6	54
¹ Maximum Overcurrent Protection	Unit only	110	110	125	50	50	60	40	40	45
	with power exhaust	110	125	125	50	50	60	40	40	50
² Minimum Circuit Ampacity	Unit only	97	103	110	44	47	50	35	37	40
	with power exhaust	102	108	115	47	49	53	37	39	42
Disconnect		84M14			84M13			84M13		

NOTE - Extremes of operating range are plus and minus 10% of line voltage.

¹ HACR type breaker or fuse.

² Refer to National or Canadian Electrical Code manual to determine wire, fuse and disconnect size requirements.

ELECTRICAL DATA

20 TON

20 TON STANDARD EFFICIENCY (R-22)

LGC240S2

Voltage - 60hz - 3 phase		208/230V			460V			575V		
Compressors (4)	Rated Load Amps (total)	15.4 (61.6)			7.4 (29.6)			5.9 (23.6)		
	Locked Rotor Amps (total)	124 (469)			59.6 (238.4)			49.4 (197.6)		
Outdoor Fan Motors (4)	Full Load Amps (total)	2.4 (9.6)			1.3 (5.2)			1 (4)		
	Locked Rotor Amps (total)	4.7 (18.8)			2.4 (9.6)			1.9 (7.6)		
Standard Power Exhaust Fans (2)	Horsepower (W)	1/3 (249)			1/3 (249)			1/3 (249)		
	Full Load Amps(total)	2.4 (4.8)			1.3 (2.6)			1 (2)		
	Locked Rotor Amps (total)	4.7 (9.4)			2.4 (4.8)			1.9 (3.8)		
Service Outlet 115V GFI		15 Amps			15 Amps			15 Amps		
Indoor Blower Motor	Horsepower	5	7.5	10	5	7.5	10	5	7.5	10
	Rated Load Amps	16.7	24.2	30.8	7.6	11	14	6.1	9	11
	Locked Rotor Amps	105	152	193	45.6	66	84	36.6	54	66
² Maximum Overcurrent Protection	Unit only	100	125	125	50	50	60	40	45	50
	with power exhaust	110	125	125	50	60	60	40	45	50
¹ Minimum Circuit Ampacity	Unit only	92	100	106	45	48	51	36	39	41
	with power exhaust	97	105	111	47	51	54	38	41	43
Disconnect		84M14			84M13			84M13		

20 TON HIGH EFFICIENCY (R-22)

LGA240H2

Voltage - 60hz - 3 phase		208/230V			460V			575V		
Compressors (4)	Rated Load Amps (total)	17.3 (69.2)			9 (36)			7.1 (28.4)		
	Locked Rotor Amps (total)	123 (492)			62 (248)			50 (200)		
Outdoor Fan Motors (4)	Full Load Amps (total)	2.4 (9.6)			1.3 (5.2)			1 (4)		
	Locked Rotor Amps (total)	4.7 (18.8)			2.4 (9.6)			1.9 (7.6)		
Standard Power Exhaust Fans (2)	Horsepower (W)	1/3 (249)			1/3 (249)			1/3 (249)		
	Full Load Amps(total)	2.4 (4.8)			1.3 (2.6)			1 (2)		
	Locked Rotor Amps (total)	4.7 (9.4)			2.4 (4.8)			1.9 (3.8)		
Service Outlet 115V GFI		15 Amps			15 Amps			15 Amps		
Indoor Blower Motor	Horsepower	5	7.5	10	5	7.5	10	5	7.5	10
	Rated Load Amps	16.7	24.2	30.8	7.6	11	14	6.1	9	11
	Locked Rotor Amps	105	152	193	45.6	66	84	36.6	54	66
² Maximum Overcurrent Protection	Unit only	110	125	125	60	60	70	45	50	50
	with power exhaust	110	125	150	60	60	70	45	50	50
¹ Minimum Circuit Ampacity	Unit only	100	108	114	52	55	58	41	44	46
	with power exhaust	105	113	119	54	58	61	43	46	48
Disconnect		84M14			84M13			84M13		

20 TON HIGH EFFICIENCY (R-410A)

LGA240H4

Voltage - 60hz - 3 phase		208/230V			460V			575V		
Compressors (4)	Rated Load Amps (total)	16 (64)			7.8 (31.2)			5.7 (22.8)		
	Locked Rotor Amps (total)	110 (440)			52 (208)			38.9 (155.6)		
Outdoor Fan Motors (4)	Full Load Amps (total)	2.4 (9.6)			1.3 (5.2)			1 (4)		
	Locked Rotor Amps (total)	4.7 (18.8)			2.4 (9.6)			1.9 (7.6)		
Standard Power Exhaust Fans (2)	Horsepower (W)	1/3 (249)			1/3 (249)			1/3 (249)		
	Full Load Amps(total)	2.4 (4.8)			1.3 (2.6)			1 (2)		
	Locked Rotor Amps (total)	4.7 (9.4)			2.4 (4.8)			1.9 (3.8)		
Service Outlet 115V GFI		15 Amps			15 Amps			15 Amps		
Indoor Blower Motor	Horsepower	5	7.5	10	5	7.5	10	5	7.5	10
	Rated Load Amps	16.7	24.2	30.8	7.6	11	14	6.1	9	11
	Locked Rotor Amps	105	152	193	45.6	66	84	36.6	54	66
² Maximum Overcurrent Protection	Unit only	110	125	125	50	60	60	40	45	50
	with power exhaust	110	125	125	50	60	70	40	45	50
¹ Minimum Circuit Ampacity	Unit only	95	102	109	46	50	53	35	38	40
	with power exhaust	100	107	114	49	52	55	37	40	42
Disconnect		84M14			84M13			84M13		

NOTE - Extremes of operating range are plus and minus 10% of line voltage.

¹ HACR type breaker or fuse.

² Refer to National or Canadian Electrical Code manual to determine wire, fuse and disconnect size requirements.

ELECTRICAL DATA**25 TON****25 TON STANDARD EFFICIENCY (R-22)****LGC300S2**

Voltage - 60hz - 3 phase		208/230V			460V			575V		
Compressors (4)	Rated Load Amps (total)	18.6 (74.4)			9 (36)			7.4 (29.6)		
	Locked Rotor Amps (total)	156 (624)			75 (300)			54 (216)		
Outdoor Fan Motors (4)	Full Load Amps (total)	3 (12)			1.5 (6)			1.2 (4.8)		
	Locked Rotor Amps (total)	6 (24)			3 (12)			2.9 (11.6)		
Standard Power Exhaust Fans (2)	Horsepower (W)	1/3 (249)			1/3 (249)			1/3 (249)		
	Full Load Amps(total)	2.4 (4.8)			1.3 (2.6)			1 (2)		
	Locked Rotor Amps (total)	4.7 (9.4)			2.4 (4.8)			1.9 (3.8)		
Service Outlet 115V GFI		15 Amps			15 Amps			15 Amps		
Indoor Blower Motor	Horsepower	5	7.5	10	5	7.5	10	5	7.5	10
	Rated Load Amps	16.7	24.2	30.8	7.6	11	14	6.1	9	11
	Locked Rotor Amps	105	152	193	45.6	66	84	36.6	54	66
¹ Maximum Overcurrent Protection	Unit only	125	125	150	60	60	70	45	50	50
	with power exhaust	125	125	150	60	60	70	50	50	60
² Minimum Circuit Ampacity	Unit only	108	116	122	52	56	59	43	46	48
	with power exhaust	113	121	127	55	58	61	45	48	50
Disconnect		84M14			84M13			84M13		

25 TON STANDARD EFFICIENCY (R-410A)**LGC300S4**

Voltage - 60hz - 3 phase		208/230V			460V			575V		
Compressors (4)	Rated Load Amps (total)	22.4 (89.6)			10.6 (42.4)			7.7 (30.8)		
	Locked Rotor Amps (total)	149 (596)			75 (300)			54 (216)		
Outdoor Fan Motors (4)	Full Load Amps (total)	3 (12)			1.5 (6)			1.2 (4.8)		
	Locked Rotor Amps (total)	6 (24)			3 (12)			2.9 (11.6)		
Standard Power Exhaust Fans (2)	Horsepower (W)	1/3 (249)			1/3 (249)			1/3 (249)		
	Full Load Amps(total)	2.4 (4.8)			1.3 (2.6)			1 (2)		
	Locked Rotor Amps (total)	4.7 (9.4)			2.4 (4.8)			1.9 (3.8)		
Service Outlet 115V GFI		15 Amps			15 Amps			15 Amps		
Indoor Blower Motor	Horsepower	5	7.5	10	5	7.5	10	5	7.5	10
	Rated Load Amps	16.7	24.2	30.8	7.6	11	14	6.1	9	11
	Locked Rotor Amps	105	152	193	45.6	66	84	36.6	54	66
¹ Maximum Overcurrent Protection	Unit only	125	150	150	60	70	70	50	50	60
	with power exhaust	150	150	175	70	70	80	50	50	60
² Minimum Circuit Ampacity	Unit only	124	132	138	59	63	66	44	47	49
	with power exhaust	129	137	143	62	65	68	46	49	51
Disconnect		84M14	84M15		84M13			84M13		

NOTE - Extremes of operating range are plus and minus 10% of line voltage.

¹ HACR type breaker or fuse.² Refer to National or Canadian Electrical Code manual to determine wire, fuse and disconnect size requirements.**OUTDOOR SOUND DATA**

*Unit Model No.	Octave Band Sound Power Levels dBA, re 10 ⁻¹² Watts							¹ Sound Rating Number (dB)
	Center Frequency - HZ							
	125	250	500	1000	2000	4000	8000	
156H, 180S, 180H	80	83	87	88	84	80	71	93
210S, 210H, 240S, 240H	77	83	87	87	84	80	71	92
300S	80	84	87	87	83	77	64	93

NOTE - The octave sound power data shown does not include tonal correction.

¹ Tested according to ARI Standard 270-95 test conditions and ANSI Standard S1.32-1981.

UNIT CLEARANCES - INCHES (MM)

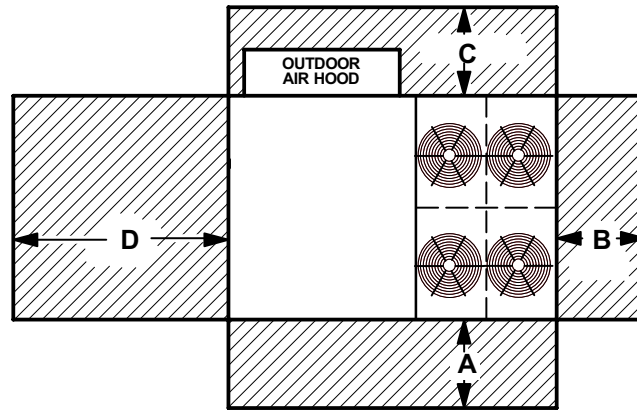

¹ Unit Clearance	A		B		C		D		Top Clearance
	in.	mm	in.	mm	in.	mm	in.	mm	
Service Clearance	60	1524	36	914	36	914	66	1676	Unobstructed
Clearance to Combustibles	36	914	1	25	1	25	1	25	
Minimum Operation Clearance	45	1143	36	914	36	914	41	1041	

NOTE - Entire perimeter of unit base requires support when elevated above the mounting surface.

¹ **Service Clearance** - Required for removal of serviceable parts.

Clearance to Combustibles - Required clearance to combustible material.

Minimum Operation Clearance - Required clearance for proper unit operation.

SECTRA™ COMMERCIAL ZONING SYSTEM - FACTORY INSTALLED

SECTRA SINGLE ZONE CONTROL

Module monitors and controls heating, cooling and economizer functions of Lennox' S-Class™ and L Series® rooftop equipment configured for single-zone applications. Up to 50 zoned (bypass or VFD) and single zone (DDC or communicating thermostat) units can be combined on a single Sectra Commercial Zoning System network (maximum of 120 LonWorks® nodes). Allows 2 stage heat/3 stage cool demands to operate four stages of cooling and heating by grouping compressors/heat stages in the factory IMC configuration. Uses LonTalk protocol, conforming with LonMark® Rooftop Unit Functional Profile. Occupied, unoccupied, standby, override, start-up and wait, cooling, heating, emergency heat, off, disabled, freeze protect, manual position, and fan-only modes. Factory installed complete with return air temperature sensor and blower proving switch. Controls economizer damper via minimum position, proportional free cooling (sensible, single enthalpy, or differential enthalpy), or demand control ventilation using an optional carbon dioxide sensor. Supports modulating hydronic valves for heating and/or cooling. A total of one resistive analog input, two binary inputs, and six relay outputs are available.

SECTRA BYPASS CONTROL

Module monitors and controls heating, cooling and economizer functions of Lennox' S-Class™ and L Series® rooftop equipment configured for pressure dependent constant volume bypass applications. Controls up to 18 zones per rooftop unit, with up to 50 combined zoned (bypass or VFD) and single zone (DDC or communicating thermostat) units on a single Sectra Commercial Zoning System network (maximum of 120 LonWorks nodes). Allows 2 stage heat/3 stage cool demands to operate four stages of cooling and heating by grouping compressors/heat stages in the factory IMC configuration. Modulates bypass damper to maintain constant static pressure input as zone dampers modulate. Occupied, unoccupied, vent and shutdown modes. Factory installed complete with return air temperature sensor, discharge air temperature sensor, and blower proving switch. Controls economizer damper via minimum position, proportional free cooling (sensible, single enthalpy, or differential enthalpy), or demand control ventilation using an optional carbon dioxide sensor. Supports modulating hydronic valves for heating and/or cooling. A total of eight analog inputs, eight binary inputs, eight binary outputs, and six analog outputs are available.

SECTRA VFD CONTROL

Module works with the Integrated Modular Controller (IMC) control module to monitor and control heating and cooling functions of Lennox' S-Class™ and L Series® rooftop equipment configured for pressure dependent, variable air volume applications with a factory mounted variable frequency drive (VFD). Controls up to 18 zones per rooftop unit, with up to 50 combined zoned (bypass or VFD) and single zone (DDC or communicating thermostat) units on a single Sectra Commercial Zoning System network (maximum of 120 LonWorks nodes). Module communicates with IMC using blower enable (G), occupied (OCP), discharge cooling enable (Y1), and discharge heating enable (W1) digital outputs. IMC modulates VFD to maintain constant static pressure input as zone dampers modulate. IMC controls 4 stage heat/4 stage cool individually based on discharge air temperature input. Economizer, demand control ventilation, power exhaust, and other unit functionality are controlled directly by the IMC.

AFTERMARKET ZONING SYSTEMS

See "Aftermarket Zoning System Interface" in the Controls Application Guide section of this document.

SECTRA™ COMMERCIAL ZONING SYSTEM - FIELD INSTALLED

SECTRA ROOFTOP UNIT CONTROL KITS

Single Zone Control - Includes controller, blower proving switch, return air temperature sensors, mounting bracket, and wiring harness

Sectra Single Zone Control - L Series® 7.5 to 30 ton (CAV Models) C0CTRL03BD1L

Sectra Single Zone Control - L Series® 3 to 6 ton, S-Class™ 35 to 50 ton (CAV Models) C0CTRL03EA1L

Bypass Control - Includes controller, blower proving switch, return and discharge air temperature sensors, mounting bracket, and wiring harness

Sectra Bypass Control - L Series® 7.5 to 30 ton C0CTRL04BD1L

Sectra Bypass Control - L Series® 3 to 6 ton, S-Class™ 35 to 50 ton C0CTRL04EA1L

Sectra VFD Control -- Includes controller and wiring harness to communicate with IMC controller

Sectra VFD Control - L Series® 25-30 ton (300H - 360H) (VFD Models) C0CTRL05BD1L

Sectra VFD Control - S-Class™ 35 to 50 ton (VFD Models) C0CTRL05EA1L

NOTE - All Rooftop Unit Control Kits require 75VA transformer (COMISC31AE1-)

SECTRA ROOFTOP UNIT CONTROL SENSORS



Temperature -- Wall mount, three hour override button, override status LED, and setpoint adjust C0SNAJ00AE1-

Temperature -- Wall mount, without override or setpoint adjust C0SNZN01AE1-



Temperature -- Wallplate, without override or setpoint adjust C0SNZN05AE1-

Temperature - Duct mount, discharge air C0SNDC00AE1-

CO₂ - Wall mount white case, no display C0SNSR52AE1L

CO₂ - Wall mount, black case, no display (UL rated for interior duct and plenum mounting) C0SNSR53AE1L

CO₂ - Wall mount, white case, digital display C0SNSR50AE1L

CO₂ - Duct Kit - Aspiration box to mount any CO₂ sensor in duct C0MISC16AE1-

Switch - Dirty Filter C0SWCH00AE1-

Relay - Baseboard auxiliary heat C0MISC91AE1-

SECTRA™ COMMERCIAL ZONING SYSTEM - FIELD INSTALLED

SECTRA SCHEDULER



Scheduler - Maintains schedules for up to four rooftop unit controllers C0CTRL12AE1L
 NOTE - 75VA transformer (C0MISC31AE1-) required

SECTRA NETWORK DISPLAY



Network Display - Local interface to monitor and control Sectra network setpoints, schedules and alarms C0CTRL20AE1L
 NOTE - 75VA transformer (C0MISC31AE1-) required

SECTRA NETWORK MODEM

Modem - allows remote telephone communications to network, includes transformer C0MISC40AE1L
 Modem cable -- DB9 to DB25 serial cable to connect modem to Serial Lontalk Adaptor C0MISC42AE1-
 NOTE: Serial Lontalk Adaptor (C0MISC45AE1-) required to connect modem to Sectra network

SECTRA SERIAL LONTALK® ADAPTOR



Serial Lontalk Adaptor - Provides communication between Sectra network and PC or modem . . . C0MISC45AE1-
 Operations Kit - Cable to connect Serial Lontalk Adaptor to PC, 120/24VAC transformer for Serial Lontalk Adaptor with power cord, instructions C0MISC44AE1-
 NOTE: Modem (C0MISC40AE1L) and modem cable (C0MISC42AE1-) required for remote communication

SECTRA SOFTWARE

Lennox Commercial Controls Selection Software - Includes Sectra® (and L Connection®) Estimator Software for product selection and submittal information C0SOFT40AE1-
 Sectra™ Configurator - Windows® based PC software to configure, monitor and control Sectra system C0SOFT10AE1-

SECTRA ZONE CONTROLLER



Zone Controller - Combined controller/actuator modulates zone damper based on signal from zone sensor, reports demand to rooftop unit controller C0CTRL60AE1L
 NOTE - 75VA transformer (C0MISC31AE1-) required
 - Compatible with Sectra Bypass and Sectra VFD applications

SECTRA BYPASS DAMPER ACTUATOR



Bypass Damper Actuator - Modulates bypass damper based on signal from rooftop unit controller C0MISC0AE1L
 NOTE - 75VA transformer (C0MISC31AE1-) required



Static Pressure Transducer - Sends pressure signal to Sectra rooftop unit controller for bypass control C0SNSR20AE1-

SECTRA TRANSFORMER

Transformer - 75VA, 120/208/220V primary, 24V secondary at rated power output C0MISC31AE1-
 NOTE - Transformer can be used with unit controllers, Sectra Network Display, etc.

SECTRA LONWORKS® NETWORK WIRING

LonWorks Wire - 1000 feet, 22AWG, unshielded twisted pair, plenum rated, daisy chain on free topology transceiver (FTT) network C0MISC03AE1-
 Four Way Repeater - Required for Sectra networks exceeding 4600 ft. (1400 m) in length or a combined 60 LonWorks nodes C0MISC50AE1L
 Termination Module - Required at each non-repeater termination point (typically two per Sectra network) C0MISC90AE1-
 NOTE - If repeater is present, one termination module is required per subnet - maximum four subnets.

OPTIONAL UNIT CONTROLLERS AND SYSTEMS INTEGRATION

FACTORY OR FIELD INSTALLED

NOVAR ETM-2051

Electronic Thermostat Module (ETM)/Blower Proving Switch/Return Air Sensor/Discharge Air Sensor/Wiring Harness -

Module monitors unit operation from different sensors installed in unit and monitors unit diagnostic codes of the IMC. The ETM has outputs for 2 stage heat/2 stage cool, 7 relay outputs: fan Cool 1, Cool 2, Heat 1, Heat 2, Economizer, Night Mode, automatic or continuous blower operation, economizer damper operation and night setback, features: day/occupied mode with low enthalpy (outdoor air damper open), high enthalpy (outdoor air damper closed) or night/unoccupied mode (outdoor air damper closed), network communication (RS-485, shielded pair twisted wire), local override (1 to 255 minutes), watchdog function, fail-safe operation, ETM allows units to be "daisy chained" together (up to 31 units) to be operated from one central location with an "executive" type control processor (on-site or off-site), built-in time delays, built-in unit operating defaults, diagnostic LED's indicate various operating functions, surge suppression protects ETM against lightning or voltage spikes, Blower Proving Switch monitors blower operation and locks out unit in case of blower failure, Return Air Sensor provides input to ETM module to determine heating or cooling operation and number of stages required, Discharge Air Sensor monitors leaving air temperature during unit operation.

C0CTRL35EA1L

FIELD INSTALLED

Room Temperature Sensor with Adjustable Temperature Setpoint and Built-in Night Setback Override Button - Provides input to ETM module to determine heating or cooling operation and number of stages required. Temperature setpoint adjustment. Override button allows momentary override of night setback during unoccupied mode. Status LED.

C0SNZN75AE1-

Room Temperature Sensor - Provides input to ETM module to determine heating or cooling operation and number of stages required.

C0SNZN74AE1-

Room Temperature Sensor with Switchover - Used to sense indoor space temperatures in commercial and industrial environments. In programmable "fall-back" configuration, provides capability to switch over control to a secondary sensor if the signal is lost from this sensor.

C0SNZN76AE1-

Averaging Sensor - Used for temperature averaging in a large room.

C0SNZN74AE1-

Override Switch - After Hours Remote Override Button - Wall Plate furnished.

C0SWCH20AE1-

Dirty Filter Switch - Senses static pressure increase indicating a dirty filter condition.

C0SWCH00AE1-

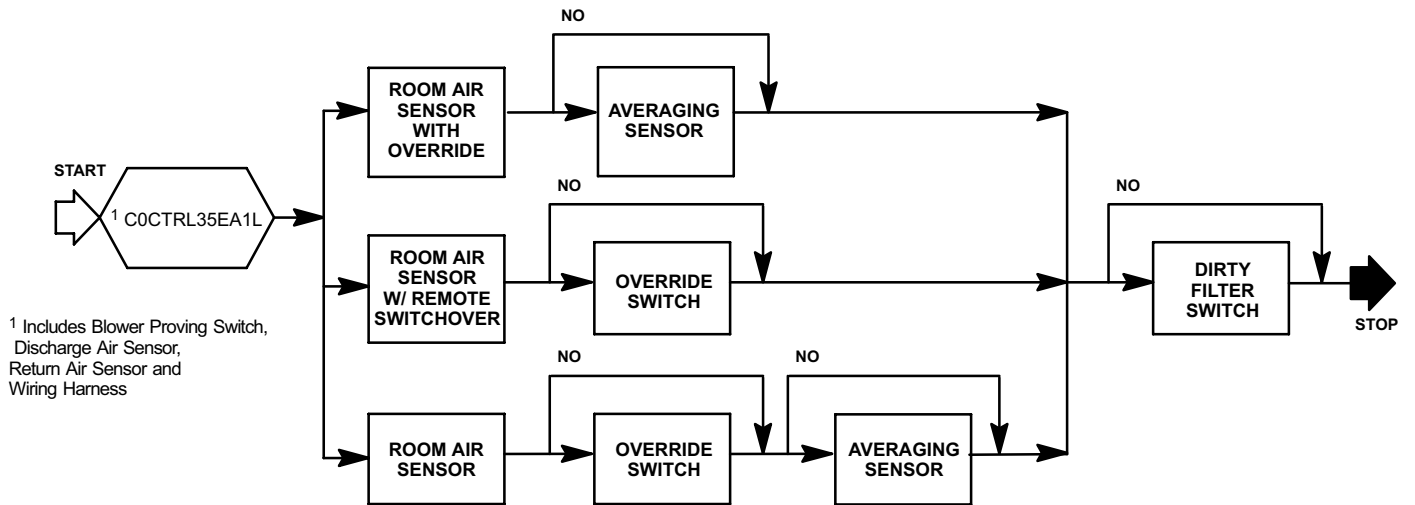

OPTIONAL UNIT CONTROLLERS AND SYSTEMS INTEGRATION

FACTORY OR FIELD INSTALLED

IMC LONTALK® MODULE

The IMC LonTalk module allows communication between the Lennox IMC (M1-7, v5.10+) controller and a LonWorks® network. The module translates input and output variables between the Lennox protocol and the LonTalk protocol. The IMC LonTalk Module has been developed to communicate with building automation systems that support the LonMark® Space Comfort Controller (SCC) or Discharge Air Controller (DAC) functional profiles. A Lennox zone sensor, a LonTalk network zone sensor, or a LonTalk thermostat or DDC controller may be used to send the zone temperature or thermostat demands to the IMC.

The IMC LonTalk Module utilizes an FTT-10A free topology transceiver communicating at 78.8 kbps. It is compatible with Echelon® qualified twisted pair cable such as Lennox model no. C0MISC03AE1-, Belden 8471 or NEMA Level 4 cables. The Module can communicate up to 1640 ft. (500m) with no repeater and up to 3200 ft. (1000m) with one repeater. The LonWorks limit of 64 nodes per segment applies to this device. One termination module, Lennox model no. C0MISC90AE1- is required for free topology segments and two are required for doubly terminated bus topology segments. Termination modules must be field provided.

C0CTRL51AE1L

NOTE: A qualified systems integrator with adequate training and experience is required to integrate and commission the IMC LonTalk Module into a third-party LonTalk building automation system. A LonWorks network configuration software tool such as LonMaker® (or equivalent) is required to commission the LonWorks network. An external interface file (XIF) will be made available upon request.

LONWORKS NETWORK VARIABLES - INPUTS

LonMark Name	Variable Type	Description
nviApplicMode	SNVT_hvac_mode	Unit application mode
0-Auto		Auto (unit-defined operation)
1-Heat		Demand for full heating
3-Cool		Demand for full cooling
6-Off		Unit off (IMC standby)
9-Fan only		Main fan (blower) on
254-Reset		Force controller reset
255-Null		Same as auto.
nviOAMinPos		SNVT_lev_percent
nviOccManCmd	SNVT_occupancy	Zone occupied status
nviOccSchedule	SNVT_tod_event	Occupancy scheduler input used to put controller unit into different occupancy modes
nviOccSensor	SNVT_occupancy	Occupancy sensor input. Used to indicate the presence of occupants
nviSpaceDehumSP	SNVT_lev_percent	Zone relative humidity set point
nviSetpoint	SNVT_temp_p	Zone temperature setpoint
nviSetptOffset	SNVT_temp_p	Zone temp setpoint offset
nviSpaceTemp	SNVT_temp_p	Remote zone temp.
nviEmergOverride	SNVT_hvac_emerg	Emergency smoke override
nviComprEnable	SNVT_switch	Compressor enable
nviPriHeatEnable	SNVT_switch	Primary heat enable
nviAuxHeatEnable	SNVT_switch	Auxiliary heat enable

OPTIONAL UNIT CONTROLLERS AND SYSTEMS INTEGRATION

IMC LONTALK® MODULE (Continued)

LONWORKS NETWORK VARIABLES - OUTPUTS

LonMark Name	Variable Type	Description
snvoIMCVersion	Manufacturer defined	IMC firmware version. D0-D3 (ASCII)
snvoUnitID	Manufacturer defined	Unit ID. \$3x-Gas/Elect \$4x-Elect/Elect \$5x-Heat Pump
nvoUnitStatus:	SNVT_hvac_status	Unit operation mode (i.e. cool, heat, etc)
1 - HVAC heat		
2 - HVAC morning warmup		
3 - HVAC cool		
5 - HVAC pre-cool		
6 - HVAC off		
7 - HVAC test		
8 - HVAC emergency heat		
9 - HVAC fan only		
12 - HVAC max heat		
14 - HVAC dehumidification		
129 - HVAC fresh air heating		
131 - HVAC fresh air cooling		
145 - HVAC defrost 1		
161 - HVAC defrost 2		
177 - HVAC defrost 1 2		
nvoSpaceTemp	SNVT_temp_p	Zone Temperature, effective
nvoDischAirTemp	SNVT_temp_p	Supply air temperature
nvoEffectOccup	SNVT_occupancy	Zone occupied status
nvoLocalOATemp	SNVT_temp_p	Outdoor air temperature
nvoLocalSpaceTemp	SNVT_temp_p	Zone Temperature, local
nvoOADamper	SNVT_lev_percent	Economizer damper position
nvoHeatPrimary	SNVT_lev_percent	Primary heating status
nvoHeatSecondary	SNVT_lev_percent	Heat pump electric strip heating status
nvoCoolPrimary	SNVT_lev_percent	Cooling compressor 1-4 status (on/off)
nvoEconEnabled	SNVT_switch	Economizer outdoor air suitable
nvoSupFanStatus	SNVT_switch	Supply fan status
nvoEffectSetpt	SNVT_temp_p	Zone temperature set points
snvoCurrentError	Manufacturer defined	Currently displayed error code
snvoCommStatus	Manufacturer defined	IMC Communicating
snvoErrorPointer	Manufacturer defined	Error pointer. This value points to the next available alarm code location. It runs from 0 to 83 and then returns to 0. Tracking this value and using the ten most recent IMC error codes (next variable) allows an application to 1) determine when new errors are logged by the IMC, 2) what those errors are, and 3) if any errors have been missed due to network delays or other reasons.
snvoMostRecErr1-10	Manufacturer defined	Alarm codes listed in the IMC manual
nvoSpaceCO2	SNVT_ppm	Zone CO ₂ level (PPM), local
nvoSpaceRHEff	SNVT_lev_percent	Zone relative humidity, effective
nvoSpaceRH	SNVT_lev_percent	Zone relative humidity, local
nvoEffSpaceDHSP	SNVT_lev_percent	Zone relative humidity set point
nvoDehumidifier	SNVT_switch	Dehumidification status
nvoRATemp	SNVT_temp_p	Return air temperature
nvoBldgStatPress	SNVT_press_p	Analog Input 2 (GP1 - VAV Bldg Static)
nvoDuctStatPress	SNVT_press_p	Analog Input 1 (GP1 - VAV Supply Static)
nvoExhFanStatus	SNVT_switch	Exhaust fan status

OPTIONAL UNIT CONTROLLERS AND SYSTEMS INTEGRATION

FACTORY OR FIELD INSTALLED

IMC BACNET® MODULE

The IMC BACnet module allows communication between the Lennox IMC (M1-7, v5.10+) controller and a BACnet MSTP network. The module translates input and output variables between the Lennox protocol and the BACnet protocol. The IMC BACnet Module has been developed to communicate with building automation systems that support the BACnet Application Specific Controller (B-ASC) device profile. A Lennox zone sensor, a BACnet network zone sensor, or a BACnet thermostat or DDC controller may be used to send the zone temperature or thermostat demands to the IMC.

The IMC BACnet Module is compatible with MSTP EIA-485 daisy-chain networks communicating at 38.4 kbps. It is compatible with twisted pair, shielded cable such as Lennox model nos. C0MISC00AE1-, C0MISC04AE1- or C0MISC01AE1- or Belden 8761, 88761. A maximum of 31 IMC BACnet Modules can be included per network. The BACnet MSTP maximum total bus length (without repeater) of 850 ft. (260m) applies to this device. A 120 ohm resistor must be added to the last module in the daisy chain (included in field kit).

C0CTRL50AE1L

NOTE: A qualified systems integrator with adequate training and experience is required to integrate and commission the IMC BACnet Module into a third-party BACnet building automation system. A BACnet network configuration software tool is required to commission the BACnet network.

INPUTS TO IMC

BACnet Object Name	Object Type: ID: Units	Description
Application Mode Control	AO: 101:95 (No_Units)	Unit application
0 - Auto		Auto (unit-defined operation)
1 - Heat		Demand for full Heating
3 - Cool		Demand for full Cooling
6 - Off		Unit Off (IMC stand by)
9 - Fan only		Main fan (blower) on
228 - Cool 1		Thermostat input Y1
232 - Cool 2		Thermostat input Y2
236 - Cool 3		Thermostat input Y1 & Y2
225 - Heat 1		Thermostat input W1
226 - Heat 2 (heat pump only)		Thermostat input W2 (heat pump emergency heat)
227 - Heat 3		Thermostat input W1 & W2
229 - Supermarket Reheat Lo		Thermostat input Y1 & W1
230 - Supermarket Reheat Hi		Thermostat input Y1 & W2
254 - Reset		Force controller reset
255 - Null		Same as auto.
Outdoor Air Min Pos Control	AO: 102 : 98 (Percent)	Min economizer damper position
Occupancy Override Control	AO: 103: 95 (No_Units)	Zone occupied status
Occupancy Scheduler Control	AO: 104: 95 (No_Units)	Occupancy scheduler input used to put controller unit into different occupancy modes.
Occupancy Sensor Input	AO: 107: 95 (No_Units)	Occupancy sensor input. Used to indicate the presence of occupants
Space Dehumidification Setpt	AO: 108: 98 (Percent)	Zone relative humidity set point
Temperature Setpoint (abs)	AO: 109: 64 (Degrees - Fahrenheit)	Zone temperature setpoint
Temperature Setpoint Offset	AO: 110: 64 (Degrees - Fahrenheit)	Zone temp setpoint offset
Space Temperature Input	AO: 113: 64 (Degrees - Fahrenheit)	Remote zone temp.
Emergency Override Control	AO: 114: 95 (No_Units)	Emergency smoke override
Compressor Enable Control	AO: 115: 98 (Percent)	Compressor enable
Primary Heat Enable Control	AO: 117: 98 (Percent)	Primary heat enable
Auxiliary Heat Enable Control	AO: 119: 98 (Percent)	Auxiliary heat enable

OPTIONAL UNIT CONTROLLERS AND SYSTEMS INTEGRATION

IMC BACNET® MODULE (Continued)

OUTPUTS FROM IMC

OUTPUTS FROM IMC		
IMC Version [00].....[07]	AI: 200-207 : 95 (No_Units)	IMC firmware version. (null terminated ASCII)
Unit ID	AI: 231 : 95 (No_Units)	Unit ID \$3x-Gas/Elect. \$4x-Elect/Elect. \$5x-Heat Pump
Unit Status	AI :232 : 95 (No_Units)	Unit operation mode (i.e. cool, heat, etc.)
1 - HVAC heat		
2 - HVAC morning warm-up		
3 - HVAC cool		
5 - HVAC pre-cool		
6 - HVAC off		
7 - HVAC test		
8 - HVAC emergency heat		
9 - HVAC fan only		
12 - HVAC max heat		
14 - HVAC dehumidification		
129 - HVAC fresh air heating		
131 - HVAC fresh air cooling		
145 - HVAC defrost 1		
161 - HVAC defrost 2		
177 - HVAC defrost 1, 2		
Space Temperature	AI: 239 : 64 : 95 (Degrees - Fahrenheit))	
Discharge Air Temperature	AI: 240 : 64 (Degrees - Fahrenheit)	Supply air temperature
Effective Occupancy	AI : 241 : 95 (No_ Unit)	Zone occupied status
Local Outside Air Temperature	AI 242 : 64 (Degrees - Fahrenheit)	Outdoor air temperature
Local Space Temperature	AI: 243 :64 (Degrees Fahrenheit)	Zone Temperature, local
Outside Air Damper	AI: 244 : 98 (Percent)	Economizer damper position
Heat Primary	AI: 245 :98 (Percent)	Primary heating status
Heat Secondary	AI: 246 : 98 (Percent)	Heat pump electric strip heating status
Cool Primary	AI: 247 : 98 (Percent)	Cooling compressor 1-4 status (on/off)
Economizer Enabled	AI: 248 : 95 (Percent)	Economizer outdoor air suitable
Supply Fan Status	AI: 250 : 98 (Percent)	Supply fan status
Space Temperature Set Point (Eff)	AI: 252 :64 (Degrees Fahrenheit)	Zone temperature set points
Current Error	AI: 253 : 95 (No_Units)	Currently displayed error code
Error Pointer	AI: 254 : 95 (No_Units)	Error pointer. This value points to the next available alarm code location. It runs from 0 to 83 and then rolls-over to 0. Tracking this value and using the ten most recent error codes (below) allows an application to determine when new errors are logged by the IMC, what those errors are, and if any errors have been missed due to network delays or for any other reason.
Most recent Error 1..10	AI: 255-264 : 95 (No_Units)	IMC alarm codes as listed in the IMC manual.
Space CO2 Sensor (Local)	AI : 274 :96 (Parts per million)	Zone CO ₂ level (PPM), local
Space Humidity (Local)	AI: 276 : 98 (Percent)	Zone relative humidity, local
Dehumidification Set Point (Eff)	AI: 278 : 98 (Percent)	Zone relative humidity set point
Dehumidification Status	AI: 279 : 95 (No_Units)	Dehumidification status
Return Air Temperature	AI: 281 :64 (Degrees Fahrenheit))	Return air temperature
Building Static Pressure	AI: 282 : 64 (Inches of water)	Analog Input 2 (GP1 - VAV Bldg Static)
Duct Static Pressure	AI: 282 : 64 (Inches of water)	Analog Input 1 (GP1 - VAV Supply Static)
Exhaust Fan Status	AI: 285 :98 (Percent)	Exhaust fan status
Controller Online	B1:100 :95 (No_Units)	IMC Communicating

OPTIONAL CONVENTIONAL TEMPERATURE CONTROL SYSTEMS - FIELD INSTALLED

COMMERCIAL TOUCHSCREEN THERMOSTAT



Intuitive Touchscreen Interface - **Two Stage Heating / Two Stage Cooling Conventional or Heat Pump** - Seven Day Programmable - Four Time Periods/Day - Economizer Output - Title 24 Compliant - ENERGY STAR® Qualified - Backlit Display - Automatic Changeover

C0STAT02AE1L

Sensors For Touchscreen Thermostat

1 Remote non-adjustable wall mount 20k temperature sensor	C0SNZN01AE1-
1 Remote non-adjustable wall mount 10k averaging temperature sensor	C0SNZN73AE1-
1 Remote non-adjustable duct mount temperature sensor	C0SNDC00AE1-
Outdoor temperature sensor	C0SNSR03AE1-

Accessories For Touchscreen Thermostat

Locking cover (clear)	C0MISC15AE1-
-----------------------------	--------------

¹ Remote sensors for C0STAT02AE1L can be applied in the following combinations: (1) C0SNZN01AE1-, (2) C0SNZN73AE1-, (2) C0SNZN01AE1- and (1) C0SNZN73AE1-, (4) C0SNZN01AE1-, (3) C0SNZN01AE1- and (2) C0SNZN73AE1.

DIGITAL NON-PROGRAMMABLE THERMOSTATS



Intuitive Interface - Automatic Changeover - Simple Up and Down Temperature Control

Two-stage heating / cooling conventional systems	C0STAT10AE1L
---	--------------

Sensor For Digital Non-Programmable Thermostats Above

Remote wall mounted temperature sensor	C0SNZN00AE1-
--	--------------



Intuitive Interface - Automatic Changeover - Backlit Display - Simple Up and Down Temperature Control

One-stage heating / cooling conventional systems	C0STAT12AE1L
---	--------------

Sensor For Digital Non-Programmable Thermostats Above

Outdoor temperature sensor	C0SNSR04AE1-
----------------------------------	--------------

Accessories For Digital Non-Programmable Thermostats Above

Optional wall mounting plate	C0MISC17AE1-
------------------------------------	--------------

WEIGHT DATA

Model Number	Net		Shipping	
	lbs.	kg	lbs.	kg
156H/180 Base Unit	2355	1070	2555	1159
156H/180 Max. Unit	2600	1179	2760	1252
210 Base Unit	2485	1127	2685	1218
210 Max. Unit	2680	1216	2880	1306
240/300S Base Unit	2535	1150	2735	1241
240/300S Max. Unit	2740	1243	2940	1334

OPTIONS / ACCESSORIES

		Weight	
		lbs.	kg.
CEILING DIFFUSERS			
Step-Down	RTD11-185	392	178
	RTD11-275	403	183
Flush	FD11-185	289	135
	FD11-275	363	165
Transitions	LASRT18	80	36
	LASRT21/24	75	34

ECONOMIZER / OUTDOOR AIR / EXHAUST

Economizer	LAREMD18/24	86	39
Barometric Relief			
Down-Flow Barometric Relief Dampers	LAGED18/24	30	14
Horizontal Barometric Relief Dampers	LAGEDH18/24	20	9
Outdoor Air Dampers			
Damper Section (down-flow) - Automatic	LAOADM18/24	52	24
Damper Section (down-flow) - Manual	LAOAD18/24	49	22
Outdoor Air Hood (down-flow)	C1HOOD10C	65	29
Power Exhaust	C1PWRE20C	62	28

HEAT EXCHANGER

High Fire Heat Exchanger		80	36
--------------------------	--	----	----

PACKAGING

LTL Packaging (less than truck load)		280	127
--------------------------------------	--	-----	-----

ROOF CURBS - STANDARD

Down-Flow			
14 in. (356 mm) height	LARMF18/36-14	160	73
24 in. (610 mm) height	LARMF18/36-24	220	100
Horizontal			
26 in. (660 mm) height	LARMFH18/24-26	420	191
37 in. (940 mm) height	LARMFH18/24-37	580	263
30 in. (762 mm) height	LARMFH30/36-30	445	202
41 in. (1041 mm) height	LARMFH30/36-41	725	329

ROOF CURBS - CLIPLOCK 1000

Down-Flow			
14 in. (356 mm) height	LARMF18/30S-14	165	75
18 in. (457 mm) height	LARMF18/30S-18	193	88
24 in. (610 mm) height	LARMF18/30S-24	234	106
Horizontal			
26 in. (660 mm) height	LARMFH18/24S-26	457	207
37 in. (940 mm) height	LARMFH18/24S-37	491	223
30 in. (762 mm) height	LARMFH30/36S-30	456	207
41 in. (1041 mm) height	LARMFH30/36S-41	480	218

Base Unit - The unit with low fire heat exchanger NO OPTIONS.

Max. Unit - The unit with ALL OPTIONS Installed. (High Input Heat Exchanger, Economizer, Power Exhaust Fans, Controls)

DIMENSIONS - INCHES (MM)

Model Number	CORNER WEIGHTS								CENTER OF GRAVITY			
	AA		BB		CC		DD		EE		FF	
	lbs.	kg	lbs.	kg	lbs.	kg	lbs.	kg	inch	mm	inch	mm
156H/180 Base Unit	539	244	467	212	626	284	723	328	50	1270	38-1/2	978
156H/180 Max. Unit	597	271	600	272	703	319	700	318	54	1372	41-1/2	1054
210 Base Unit	523	237	497	225	714	324	751	341	52-1/2	1334	37	940
210 Max. Unit	625	283	594	269	712	323	749	340	52-1/2	1334	41	1041
240/300S Base Unit	521	236	534	242	749	340	732	332	54-1/2	1384	37-1/2	953
240/300S Max. Unit	626	284	606	275	742	337	767	348	53	1346	40-1/2	1029

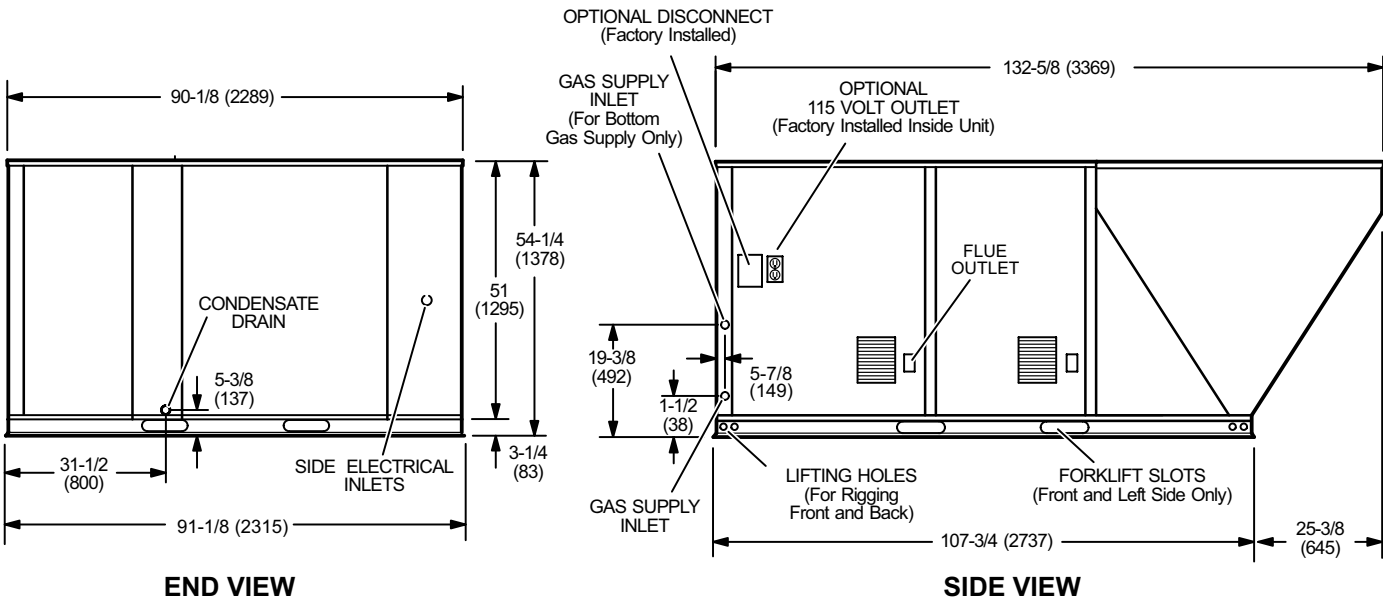
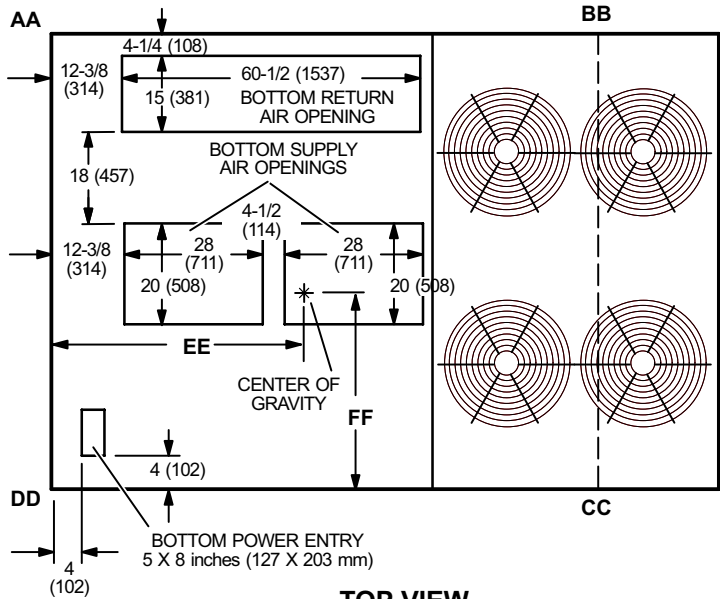

ACCESSORY DIMENSIONS - INCHES (MM)

**OPTIONAL OUTDOOR AIR HOOD DETAIL
WITH STANDARD STATIC POWER EXHAUST FANS**

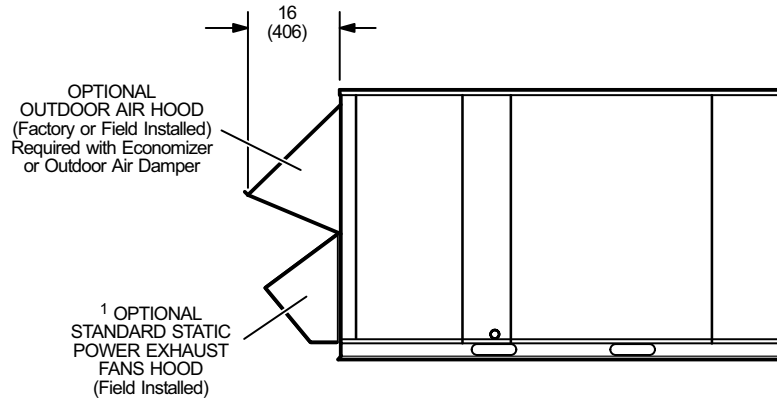

¹ Field Installed in Return Air Duct for Horizontal Applications.

HORIZONTAL BAROMETRIC RELIEF DAMPERS

(Field installed in horizontal return air duct adjacent to unit)

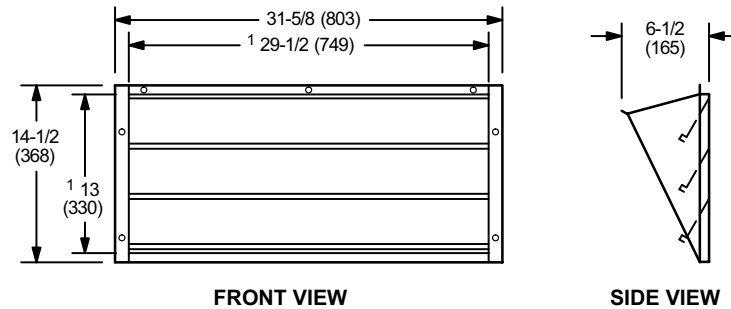

NOTE - Two furnished per order no.

¹ NOTE - Opening size required in return air duct.

ACCESSORY DIMENSIONS - INCHES (MM)

STANDARD ROOF CURBS - DOUBLE DUCT OPENING

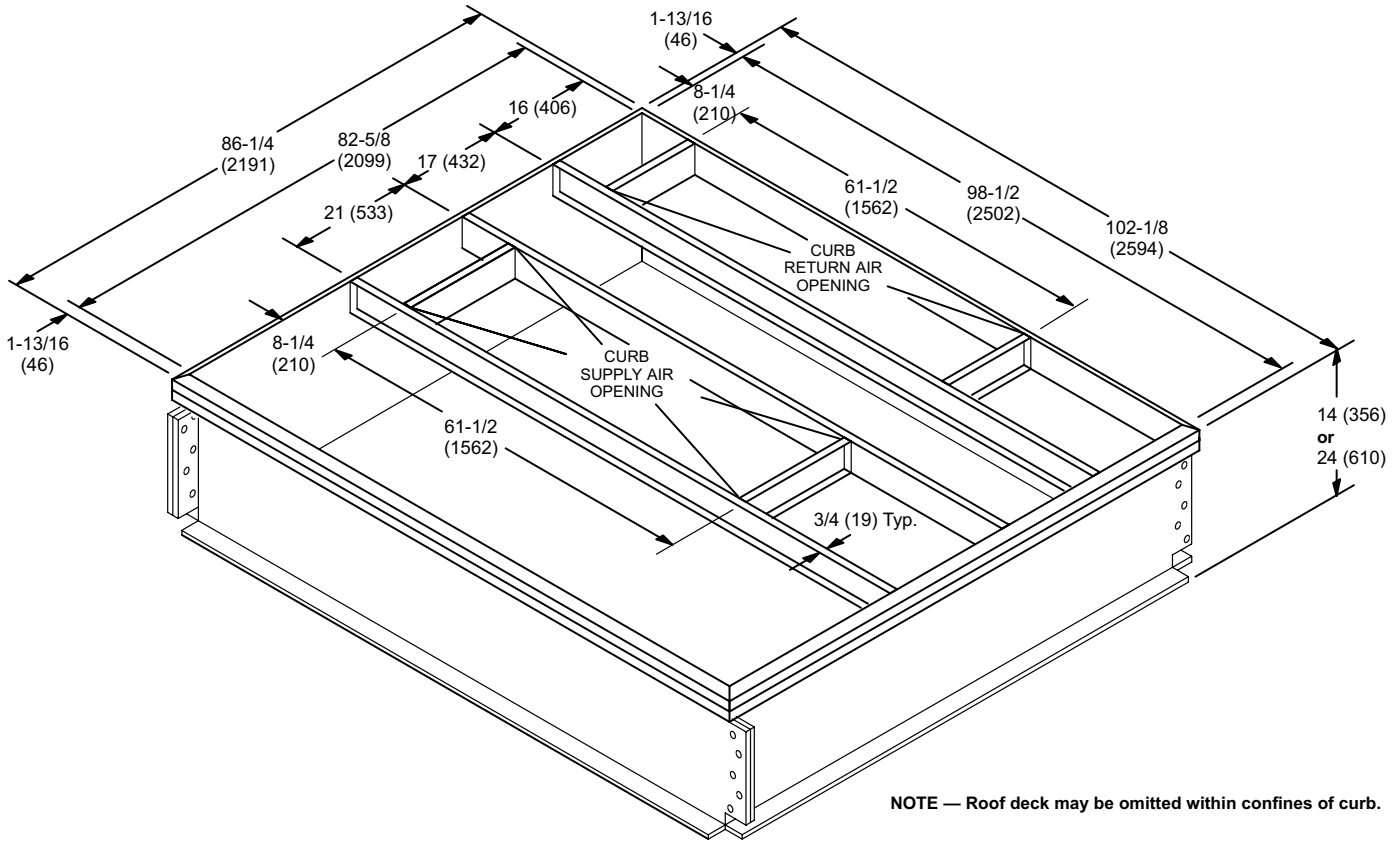

TYPICAL FLASHING DETAIL FOR ROOF CURB

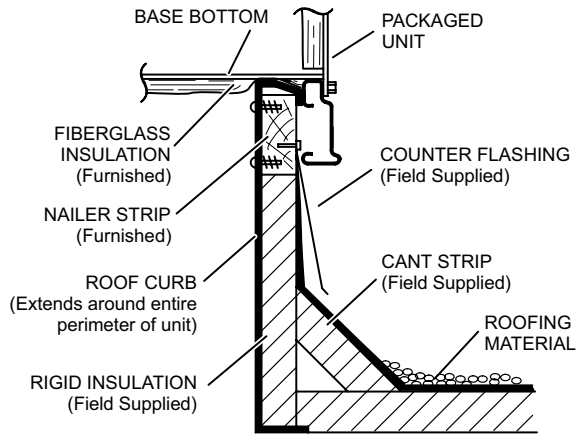

DETAIL ROOF CURB

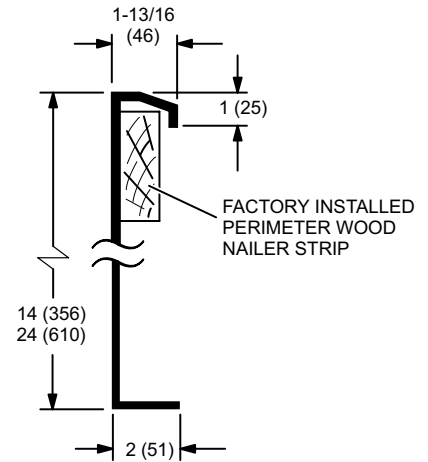

ACCESSORY DIMENSIONS - INCHES (MM)

CLIPLOCK 1000 ROOF CURBS - DOUBLE DUCT OPENING

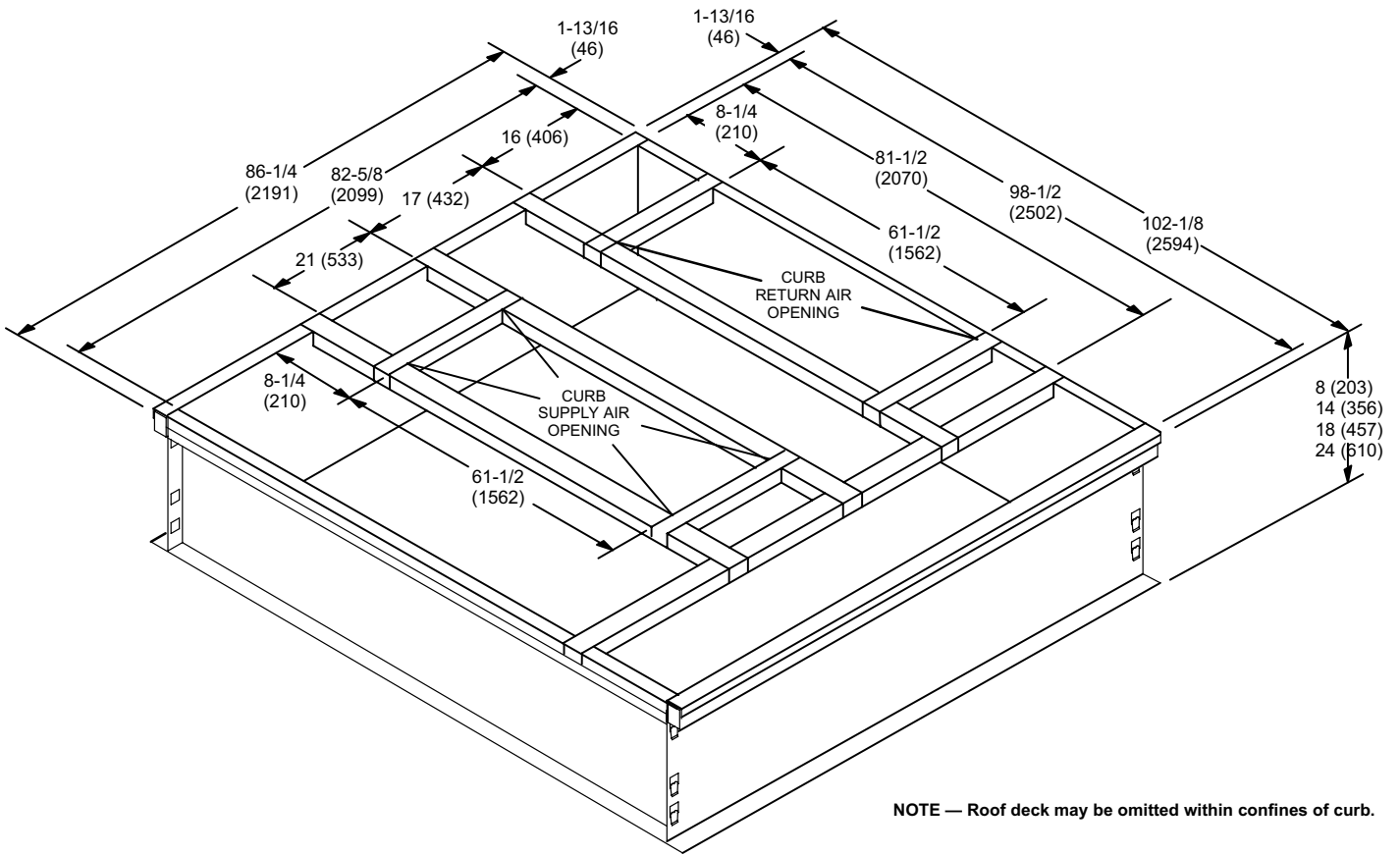

NOTE — Roof deck may be omitted within confines of curb.

TYPICAL FLASHING DETAIL FOR ROOF CURB

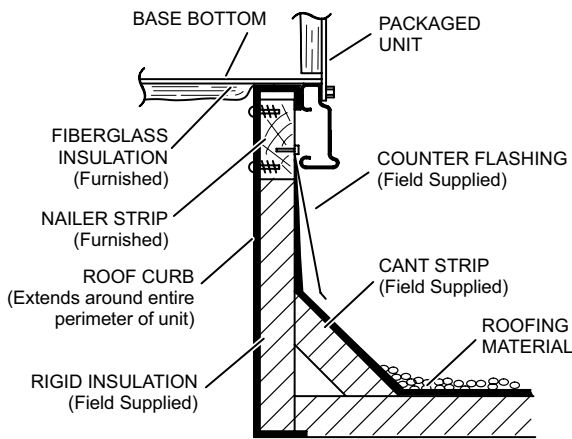

DETAIL ROOF CURB

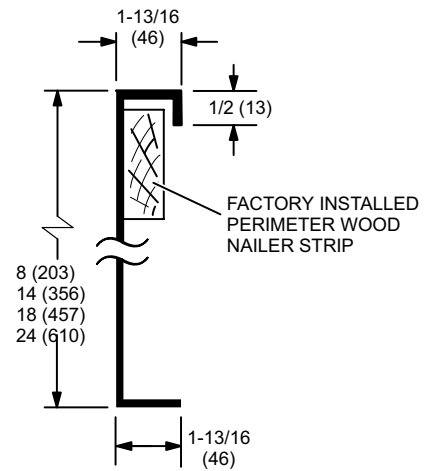

ACCESSORY DIMENSIONS - INCHES (MM)

STANDARD ROOF CURBS WITH SUPPLY & RETURN AIR TRANSITIONS FOR CEILING DIFFUSERS

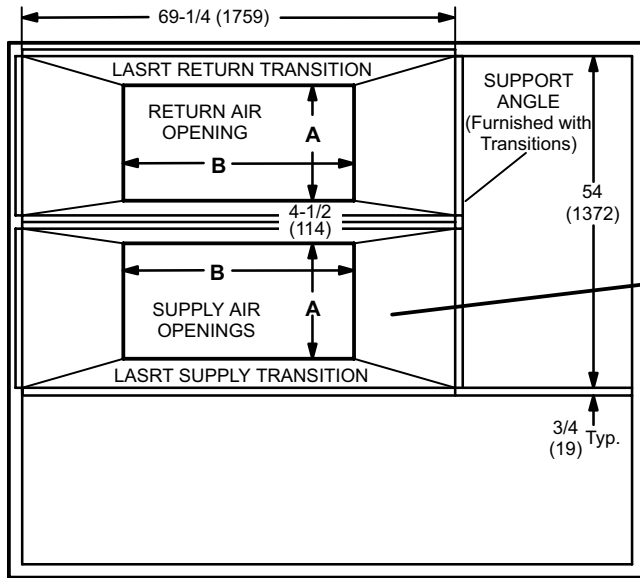

TOP VIEW

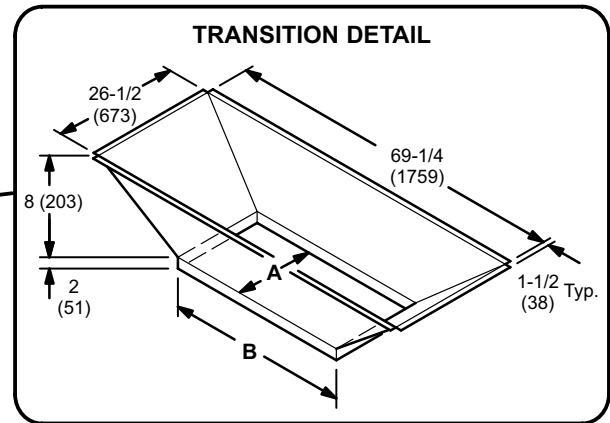

TRANSITION OPENING SIZES

Model Number	A		B	
	inch	mm	inch	mm
LASRT18	18	457	36	914
LASRT21/24	24	610	48	1219

ACCESSORY DIMENSIONS - INCHES (MM)

HORIZONTAL ROOF CURBS - Requires Optional Horizontal Return Air Panel Kit

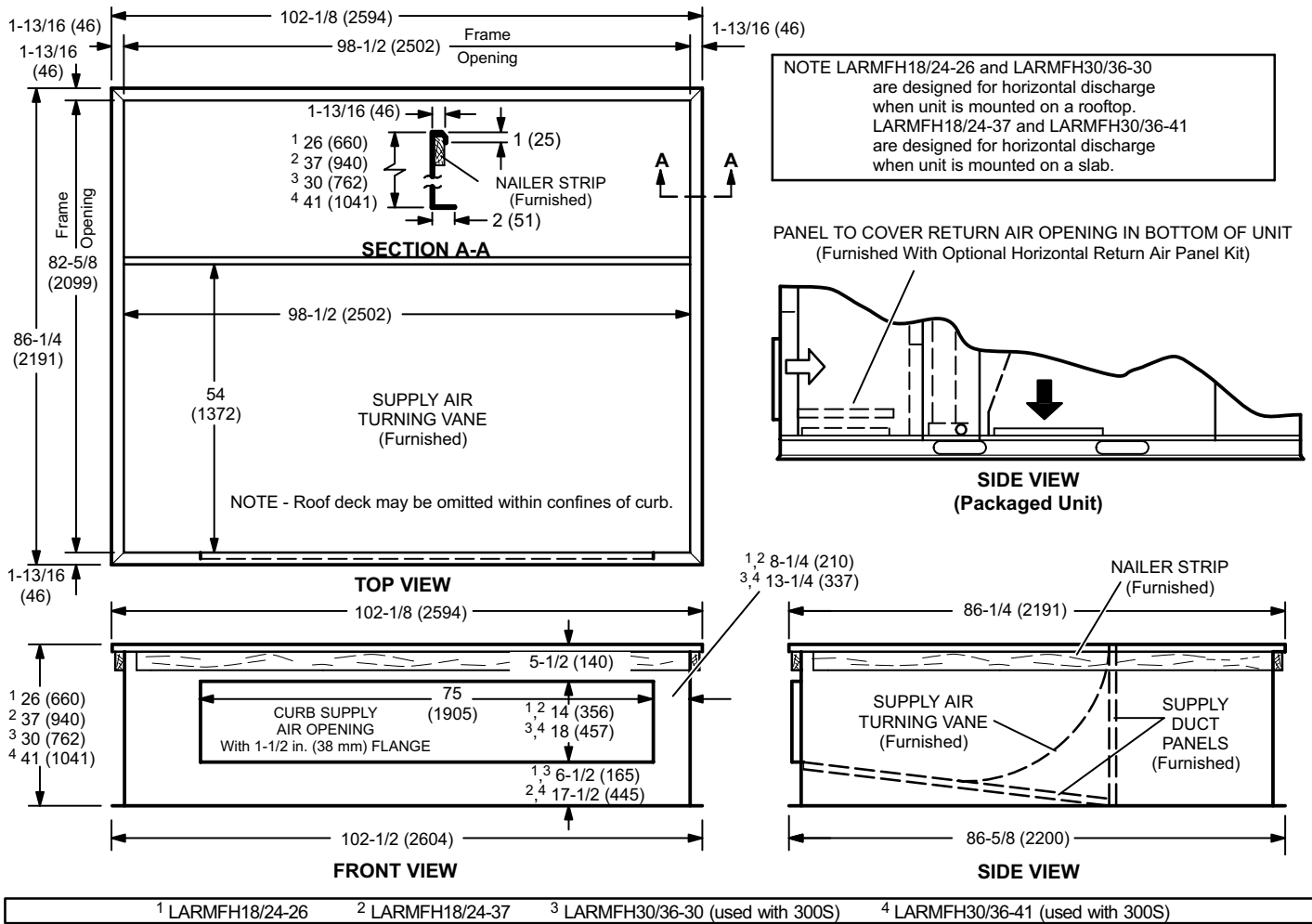

HORIZONTAL SUPPLY AND RETURN AIR OPENINGS WITH HORIZONTAL ROOF CURB

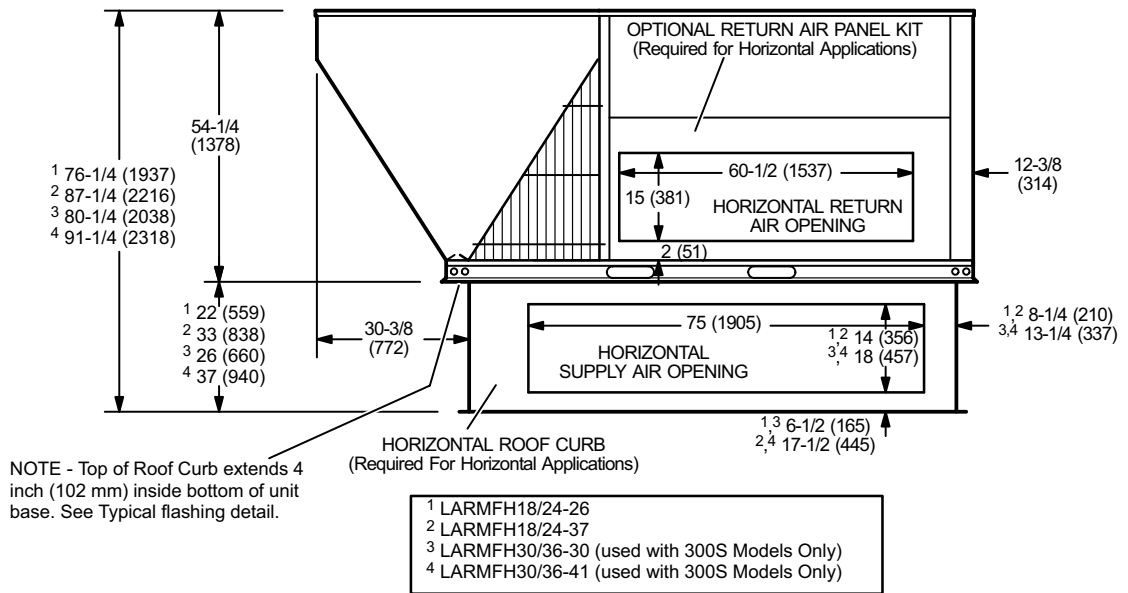

ACCESSORY DIMENSIONS - INCHES (MM)

COMBINATION CEILING SUPPLY AND RETURN DIFFUSERS

STEP-DOWN CEILING DIFFUSER

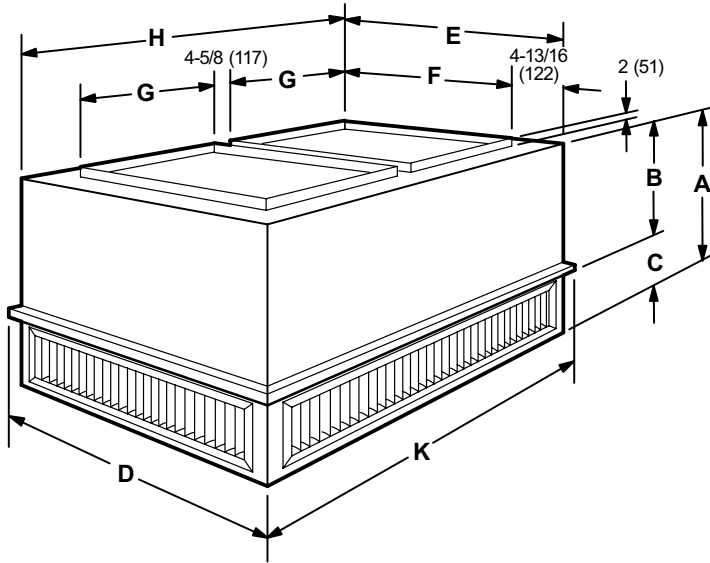

FLUSH CEILING DIFFUSER

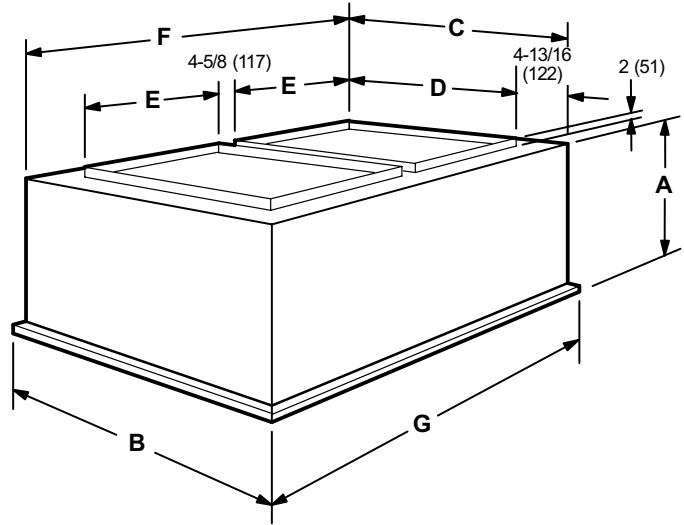

Model Number		RTD11-185	RTD11-275
A	in.	34	40
	mm	864	1016
B	in.	23-7/8	28-7/8
	mm	606	225
C	in.	10-1/8	11-1/8
	mm	257	283
D	in.	47-5/8	59-5/8
	mm	1210	1514
E	in.	45-5/8	57-7/8
	mm	1159	1470
F	in.	36	48
	mm	914	1219
G	in.	18	24
	mm	457	610
H	in.	45-5/8	57-5/8
	mm	1159	1464
K	in.	47-5/8	59-5/8
	mm	1210	1521

Model Number		FD11-185	FD11-275
A	in.	30-1/8	36-1/8
	mm	613	918
B	in.	47-5/8	59-5/8
	mm	1210	1514
C	in.	45-5/8	57-5/8
	mm	1159	1464
D	in.	36	48
	mm	914	1219
E	in.	18	24
	mm	457	610
F	in.	45-5/8	57-5/8
	mm	1159	1464
G	in.	47-5/8	59-5/8
	mm	1210	1521

GUIDE SPECIFICATIONS

This specification is for [*Lennox Industries L Series®*] rooftop units. Revise specification section number and title below to suit project requirements, specification practices and section content. Refer to CSI *MasterFormat™* for other section numbers and titles.

Optional text and text that requires a decision are indicated by **bold brackets []** and proprietary information is indicated by **bold italic brackets []**; delete text that is not needed in final copy of specification. Specifier Notes typically precede specification text; delete notes in final copy of specification. Trade/brand names with appropriate symbols typically are used in Specifier Notes; symbols are not used in specification text. Metric conversion, where used, is soft metric conversion.

Specifying Engineer Please Note - These Guide Specifications cover all L Series units (3 thru 30 tons). Please edit to accurately identify the options selected for the job.

SECTION 23 74 33 UNITARY AIR CONDITIONING EQUIPMENT

PART 1 GENERAL

PART 1.01 SUMMARY

- A. Section Includes: Packaged rooftop units and commercial packaged, gas/electric and electric/electric heat pumps.

Specifier Note: Revise paragraph below to suit project requirements. Add section numbers and titles per CSI MasterFormat and specifier's practice.

- B. Related Sections:

Specifier Note: Article below may be omitted when specifying manufacturer's proprietary products and recommended installation. Retain Reference Article when specifying products and installation by an industry reference standard. If retained, list standard(s) referenced in this section. Indicate issuing authority name, acronym, standard designation and title. Establish policy for indicating edition date of standard referenced. Conditions of the Contract or Division 1 References Section may establish the edition date of standards. This article does not require compliance with standard, but is merely a listing of references used. Article below should list only those industry standards referenced in this section. Retain only those reference standards to be used within the text of this Section. Add and delete as required for specific project.

PART 1.02 REFERENCES

- A. American National Standards Institute (ANSI):
1. ANSI/ASHRAE 15 Safety Standard for Refrigeration Systems.
 2. ANSI/ASHRAE/IESNA 90.1 Energy Efficient Design of New Buildings Except Low-Rise Residential Buildings.
 3. ANSI Z21.47 Gas-Fired Central Furnaces.
- B. Air-Conditioning and Refrigeration Institute (ARI):
1. ARI 210/240 Unitary Air-Conditioning and Air-Source Heat Pump Equipment.
 2. ARI 270 Sound Rating of Outdoor Unitary Equipment.
 3. ARI 340/360 Commercial and Industrial Unitary Air-Conditioning and Heat Pump Equipment.
 4. ARI 370 Sound Rating of Large Outdoor Refrigerating and Air Conditioning Equipment.
- C. American Society of Heating, Refrigerating, and Air-Conditioning Engineers, Inc. (ASHRAE):
1. ASHRAE 52.2 Method of Testing General Ventilation Air-Cleaning Devices for Removal Efficiency by Particle Size (ANSI approved).
 2. ASHRAE 62.1 Ventilation for Acceptable Indoor Air Quality.
- D. U.S. Energy Policy Act of 1992 (EPACT).
- E. U.S. National Appliance Energy Conservation Act (NAECA):
1. NAECA 1988.
- F. National Fire Protection Association (NFPA):
1. NFPA 90A Installation of Air Conditioning and Ventilation Systems.
- G. Underwriters Laboratories, Inc. (UL):
1. UL 1995 Standard for Safety for Heating and Cooling Equipment.

GUIDE SPECIFICATIONS

Specifier Note: Article below should be restricted to statements describing design or performance requirements and functional (not dimensional) tolerances of a complete system. Limit descriptions to composite and operational properties required to link components of a system together and to interface with other systems.

PART 1.03 SYSTEM DESCRIPTION

- A. Design Requirements: Provide products and systems that have been manufactured, fabricated and installed to following criteria:
1. ANSI/ASHRAE/IESNA 90.1.
 2. ANSI Z21.47.
 3. UL 1995.
- B. Performance Requirements:
1. Packaged Gas Electric:
 - a. Natural Gas Supply Pressure: 7 in. w.c. (1.7 kPa).

Specifier Note: For belt drive blowers from models LGC036S, LGC042S, LGC048S, LGC060S, LGC072S, LGA072H, LGC090S, LGA090H, LGC102S, LGA102H, LGC120S, LGA120H, LGC150S, LGC156H, LGC180S, LGC180H, LGC210S, LGC210H, LGC240S, LGA240H, LGA248H, LGC300S, LGC300H and LGC360H single phase is not an option.

- b. LPG/Propane Supply Pressure: 11 in. w.c. (2.7 kPa).

Specifier Note: Specify 208/230V or 460V or 575V, 3-phase for L Series units from 6 - 30 ton (21.1 - 105.6 kW). Specify 208/230V, 1-phase, 208/230V, 460V or 575V, 3-phase for L Series units from 3 - 5 ton (10.6 - 17.6 kW).

2. Packaged Cooling:
 - a. Electrical Requirements for Direct Drive Blowers: 60 hz, [208/230 V, 1-phase] [208/230 V, 3-phase] [460 V, 3-phase] [575 V, 3-phase].

Specifier Note: For belt drive blowers from models LCC036S, LCC042S, LCC048S, LCC060S, LCC072S, LCA072H, LCC090S, LCA090H, LCC102S, LCA102H, LCC120S, LCA120H, LCC150S, LCC156H, LCC180S, LCC180H, LCC210S, LCC210H, LCC240S, LCA240H, LCA248H, LCC300S, LCC300H and LCC360H single phase is not an option.

- b. Electrical Requirements for Belt Drive Blowers: 60 hz, [208/230 V, 3-phase] [460 V, 3-phase] [575 V, 3-phase].

Specifier Note: Available Heat Pump units include LHA090, LHA102, LHA120, LHA150, LHA180 and LHA240 only.

3. Packaged Heat Pumps:
 - a. Electrical Requirements: 60 hz, [208/230 V, 3-phase] [460 V, 3-phase] [575 V, 3-phase].
4. ARI Rated Net Cooling Efficiency: To meet or exceed ASHRAE Standard 90.1 at rated airflow not less than 350 cfm/ton.

Specifier Note: Article below includes submittal of relevant data to be furnished by Contractor before, during or after construction. Coordinate this article with Architect's and Contractor's duties and responsibilities in Conditions of the Contract and Division 1 Submittal Procedures Section.

PART 1.04 SUBMITTALS

- A. General: Submit listed submittals in accordance with Conditions of the Contract and Division 1 Submittal Procedures.
- B. Product Data: Submit product data for specified products.
- C. Shop Drawings:
1. Submit shop drawings in accordance with Section 01 33 23 - Submittal Procedures.
 2. Indicate:
 - a. Equipment, piping and connections, together with valves, strainers, control assemblies, thermostatic controls, auxiliaries and hardware, and recommended ancillaries which are mounted, wired and piped ready for final connection to building system, its size and recommended bypass connections.
 - b. Piping, valves and fittings shipped loose showing final location in assembly.
 - c. Control equipment shipped loose, showing final location in assembly.
 - d. Dimensions, internal and external construction details, recommended method of installation with proposed structural steel support, mounting curb details, sizes and location of mounting bolt holes; include mass distribution drawings showing point loads.
 - e. Detailed composite wiring diagrams for control systems showing factory installed wiring and equipment on packaged equipment or required for controlling devices or ancillaries, accessories and controllers.

GUIDE SPECIFICATIONS

- f. Details of vibration isolation.
 - g. Estimate of sound levels to be expected across individual octave bands in dB.
 - h. Type of refrigerant used.
- D. Quality Assurance:
- 1. Test Reports: Certified test reports showing compliance with specified performance characteristics and physical properties.
 - 2. Certificates: Product certificates signed by manufacturer certifying materials comply with specified performance characteristics and criteria and physical requirements.
 - 3. Manufacturer's Instructions: Manufacturer's installation instructions.

Specifier Note: Coordinate paragraph below with Part 3 Field Quality Requirements Article herein. Retain or delete as applicable.

- E. Manufacturer's Field Reports: Manufacturer's field reports specified.
- F. Closeout Submittals: Submit the following:
- 1. Warranty: Warranty documents specified.
 - 2. Operation and Maintenance Data: Operation and maintenance data for installed products in accordance with Division 1 Closeout Submittals (Maintenance Data and Operation Data) Section. Include methods for maintaining installed products and precautions against cleaning materials and methods detrimental to finishes and performance. Include names and addresses of spare part suppliers.
 - 3. Provide brief description of unit, with details of function, operation, control and component service.
 - 4. Commissioning Report: Submit commissioning reports, report forms and schematics in accordance with Section 01 91 00 - Commissioning.

PART 1.05 QUALITY ASSURANCE

- A. Qualifications:
- 1. Installer experienced in performing work of this section who has specialized in installation of work similar to that required for this project.
 - 2. Manufacturer Qualifications: Manufacturer capable of providing field service representation during construction and approving application method.

Specifier Note: Paragraph below should list obligations for compliance with specific code requirements particular to this section. General statements to comply with a particular code are typically addressed in Conditions of the Contract and Division 1 Regulatory Requirements Section. Repetitive statements should be avoided. Current data on building code requirements and product compliance may be obtained from filter manufacturer technical support specialists.

- B. Regulatory Requirements: Provide **[Packaged gas electric] [Packaged cooling] [Packaged heat pump]** that complies with the following requirements:
- 1. ARI 210/240.
 - 2. ARI 270.
 - 3. ARI 340/360.
 - 4. ASHRAE 52.2.
 - 5. NFPA 90A.
- C. Preinstallation Meetings: Conduct pre-installation meeting to verify project requirements, manufacturer's installation instructions and manufacturer's warranty requirements. Comply with Division 1 Project Management and Coordination (Project Meetings).

PART 1.06 DELIVERY, STORAGE & HANDLING

- A. General: Comply with Division 1 Product Requirements.
- B. Ordering: Comply with manufacturer's ordering instructions and lead time requirements to avoid construction delays.
- C. Packing, Shipping, Handling and Delivery:
- 1. Deliver materials in manufacturer's original, unopened, undamaged containers with identification labels intact.
 - 2. Ship, handle and unload units according to manufacturer's instructions.
- D. Storage and Protection:
- 1. Store materials protected from exposure to harmful weather conditions.
 - 2. Factory shipping covers to remain in place until installation.

PART 1.07 PROJECT CONDITIONS

GUIDE SPECIFICATIONS

- A. Installation Location: **[Confirm design conditions and temperature.]**.

Specifier Note: Coordinate article below with Conditions of the Contract and with Division 1 Closeout Submittals (Warranty).

PART 1.08 WARRANTY

- A. Project Warranty: Refer to Conditions of the Contract for project warranty provisions.
- B. Manufacturer's Warranty: Submit, for Owner's acceptance, manufacturer's standard warranty document executed by authorized company official. Manufacturer's warranty is in addition to, and not a limitation of, other rights Owner may have under Contract Documents.

Specifier Note: Coordinate paragraph below with manufacturer's warranty requirements.

- C. Warranty: Commencing on Date of Installation.
1. Compressors: 5 years (limited).
 2. Integrated Modular Control: 3 years (limited).
 3. Other System Components: 1 year (limited).
 4. Aluminized Heat Exchangers: 10 years (limited).
 5. Stainless Steel Heat Exchangers: 15 years (limited).

PART 2 PRODUCTS

Specifier Note: Retain article below for proprietary method specification. Add product attributes, performance characteristics, material standards and descriptions as applicable. Use of such phrases as "or equal" or "or approved equal" or similar phrases may cause ambiguity in specifications. Such phrases require verification (procedural, legal and regulatory) and assignment of responsibility for determining "or equal" products.

PART 2.01 ROOFTOP UNITS

- A. Manufacturer: Lennox Industries Inc.
1. Contact: 2100 Lake Park Blvd., Richardson, TX 75080; Telephone: (800) 453-6669; website: www.lennox.com.
- B. Proprietary Products/Systems: Lennox L Series Unitary Air Conditioning Equipment, including the following equipment:
1. Cabinet: Weatherproofing tested and certified to AGA **[Rain test standards]** and soundproofing tested to ARI 270, **[]** dBA at **[]** m (**[]**) ft. free field.
 - a. Heavy gauge steel panels and full perimeter heavy gauge galvanized steel base rails.
 - b. Raised edges around duct and power entry openings in bottom of unit.
 - c. Airflow Configuration: **[Down-flow (vertical) return air] [Horizontal return airflow with Horizontal Roof Mounting Frame] [And Horizontal Return Air Panel Kit (required when converting down-flow configured unit to horizontal airflow)]**.
 - d. Power Entry: Electrical **[And gas]** lines brought through unit base or through horizontal access knockouts.
 - e. Exterior Panels: Constructed of heavy gauge, galvanized steel with 2-layer enamel paint finish.
 - f. Insulation: All panels adjacent to conditioned air fully insulated with non-hygroscopic fiberglass insulation. Unit base fully insulated.
 - g. Base Rail: Full perimeter base rail with rigging holes; 3 sides with fork slots.
 - h. Access Panels: Hinged for compressor/controls/heating areas, blower access and air filter/economizer access; and, sealed with quarter-turn latching handles and tight air and water seal.
 2. Compressor:
 - a. Copeland scroll type, hermetically sealed.
 3. Fans, General: Centrifugal, forward curved impellers, statically and dynamically balanced. **[Multi]** V-belt drive with adjustable variable pitch motor pulley.
 - a. Condenser Fan: Low sound operating, PVC coated fan guard, direct drive propeller type fans to discharge vertically.
 - b. Condenser Fan Motor: Permanently lubricated, permanent split capacitor; totally enclosed from weather, dust and corrosion; permanently lubricated ball bearings; resiliently mounted; overload protected.
 4. Evaporator Coils: Pressure and leak tested to 500 psi (3445 kPa), nonferrous coils with enhanced aluminum fins mechanically bonded to durable copper tubes.
 5. Condenser Coils:
 - a. Pressure and leak tested to 500 psi (3445 kPa), nonferrous coils with enhanced aluminum fins mechanically bonded to durable copper tubes.

GUIDE SPECIFICATIONS

Specifier Note: Specify slab construction for L Series over 6 tons (21.1 kW), excluding heat pumps.

- b. **[Formed construction] [Slab construction].**
- 6. Air Distribution:
 - a. Equipment capable of down-flow (vertical) or side (horizontal) handling of conditioned air.
 - b. Optional Equipment:

Specifier Note: The following kit is required for horizontal air handling for L Series 3 - 12 ton (10.6 - 42.2 kW) models.

- 1) Horizontal conversion kit for horizontal air handling.

Specifier Note: The following kit is required for horizontal air handling for L Series, 13 - 30 ton (45.8 - 105.6 kW) models.

- 2) Horizontal return air panel kit and horizontal roof mounting frame for horizontal air handling.
- 7. Filters: To meet NFPA 90A, air filter requirements **[Type Class 1] [Type Class 2]; [_____] % efficiency, metal framed, [Replaceable media] [Throwaway] [Standard to unit manufacturer].**
 - a. Disposable 2 inch (51 mm).
 - b. Disposable 2 inch (51 mm) pleated MERV 11 rated.
 - c. Disposable 2 inch (51 mm) pleated MERV 15 rated.
- 8. Heat Exchanger: Removable for servicing; stainless steel optional for applications where mixed air temperature below 45 degrees F (7 degrees C); E.T.L./C.S.A. design certified for outdoor installation.
- 9. Gas Heating System:
 - a. Tubular heat exchanger and inshot type gas burners constructed of aluminized steel.
 - b. Direct spark ignition; electronic flame sensor controls; flame rollout switch; limit controls and automatic redundant dual gas valve with staging control and combustion air proving switch on combustion air inducer.

Specifier Note: When LPG/propane is required, specify optional kit.

- c. Able to use LPG/propane **[With optional kit].**
- d. Complete service access provided for controls and wiring.
- 10. Electric Heating System:
 - a. Available for factory or field installation.
 - b. Heating elements of Nichrome bare wire exposed directly to airstream.
- 11. Refrigeration System:
 - a. Self-sealing, discharge, suction and liquid line service gauge ports, freeze-stats, expansion valves and full refrigerant charge.

Specifier Note: R-22 is available on all models with 3 - 30 ton (10.6 - 105.6 kW) capacities. R-410 is available on all high efficiency units and on the 6, 12.5 and 25 ton (21.1, 44 and 87.9 kW) standard efficiency models. Variable air volume with R-410a is available on 21, 25 and 30 ton (74, 88 and 105.6 kW) units.

- b. **[R22] [R-410a] [Variable air volume] [Variable air volume with R-410a].**
- c. Copper tubing not to touch sharp metal surfaces.
- d. Compressor Circuits: Automatic reset, high pressure switch; automatic reset, low pressure switch; liquid line filter-drier.
- e. Capable of operating down to 0 degrees F (-17 degrees C) without installation of additional controls.
- 12. Supply Air Blower:
 - a. **[Constant air volume with adjustable pulleys] [Variable air volume with fixed pulleys and variable frequency drive] [Variable air volume with fixed pulleys and variable frequency drive with bypass]** with motor/drive combinations and optional drive kits.
 - b. Centrifugal supply air blower with **[Permanently lubricated ball bearings and adjustable belt drive] [Sleeve bearings and multi-speed direct drive motor].**
 - c. Blower assembly **[Slides out of unit] [Is accessible]** for servicing.
 - d. Blower wheel statically and dynamically balanced.
- 13. Integrated Modular Control (IMC):
 - a. Solid state control board to operate unit.
 - b. Built-in functions include: Blower on/off delay; built-in control parameter defaults; service relay output; dirty filter switch input; dehumidistat input, economizer control; **[Gas valve delay between stages]; [ETM compatible];**

GUIDE SPECIFICATIONS

[DDC compatible]; unit diagnosis; diagnostics code storage; indoor air quality input; low ambient controls; minimum run time; night setback mode; smoke alarm mode; low pressure control; thermostat bounce delay; 3-digit display; degrees F or degrees C display, 2-stage heat/4-stage cool thermostat compatible and warm-up mode; **[Electric heat staging with optional 4-stage board]**.

14. Gas Heating Controls:
 - a. Remote thermostat[s] as indicated.
 - b. Built-in [Un] fused disconnect switch.
 - c. **[Four]** stages of heating control from **[Thermostat with optional four stage board]** **[DDC with room sensor]**.
 - d. Supply fan to turn on **[40]** seconds after heating demand is received with 8 - 60 second adjustable time delay.
 - e. Supply fan to turn off **[120]** seconds after heating demand has ended with 80 - 300 second adjustable time delay.
 - f. Adjustable delay time of **[30]** **[Value between 30 - 160]** seconds between low and high fire of 2-stage gas valve system.
 - g. Heat off delay of **[100]** **[Value between 30 - 300]** seconds after thermostat heating demand has ended.
 - h. To turn off heat and keep supply air fan running if overheat limit occurs.
 - i. Adjustable maximum overheat limit trip count during heating cycle of **[3]** **[Value between 1 - 15]**, with digital output, limit indicator.
 - j. To report error with each occurrence of overheat limit trip and to identify limit that tripped. Error code stored in nonvolatile memory.
 - k. To shut off gas heat if flame rollout occurs and to report error identifying rollout switch.
 - l. Maximum flame rollout switch trip count of **[3]** during heating cycle, with digital output, limit indicator. Maximum count limit adjustable from 1 - 6 counts.
 - m. To turn off heat if induced airflow is too low and to report error identifying pressure switch.
 - n. Maximum induced airflow pressure switch trip count of **[3]** during heating cycle, with digital output, limit indicator. Maximum count limit adjustable from 1 - 6 counts.
 - o. Error reported if gas valve not energized 2 minutes after heating demand; gas valve identified.
 - p. Maximum ignition failure count of **[3]** with digital output, limit indicator. Maximum count limit adjustable from 1 - 6 counts.
 - q. To shut off gas valve if flame not sensed. Error reported and stored in nonvolatile memory.
 - r. Delay between stages on gas valve.
 - s. To shut off unit if gas valve is energized with no demand for heat. Error reported and stored in nonvolatile memory.
15. Electric Heating Controls:
 - a. Panel board with [] stage controller.
 - b. Remote thermostat[s] as indicated.
 - c. Built-in [Un] fused disconnect switch.
 - d. Supply Fan: Start before electric elements are energized and continue operating until bonnet temperature reaches minimum setting. Include switch for continuous fan operation.
 - e. Two stages of heating control from **[Thermostat]** **[DDC]**.
 - f. Supply fan to turn off **[20]** seconds after heating demand has ended. Time delay adjustable from 0 - 300 seconds.
 - g. With delay time of **[12]** seconds between low and high heat stages. Time delay adjustable from 12 - 60 seconds.
 - h. To turn off heat and keep supply air fan running if overheat limit occurs.
 - i. Adjustable maximum overheat limit trip count of **[3]** during heating cycle with digital output, limit indicator. Maximum count limit adjustable from 1 - 15 counts.
 - j. Error reported and identified if overheat limit tripped. Error code stored in nonvolatile memory.
16. Cooling Controls:
 - a. Provide **[Smoke detectors in return]** **[Smoke detectors in supply]**.

GUIDE SPECIFICATIONS

Specifier Note: Specify b, c or d below.

- b. **[Manual] [Automatic]** outside **[And return]** air dampers for fixed outside air quantity.
- c. Remote controlled outside **[And return]** air dampers with damper operator and means for adjusting outside air quantity.
- d. Motorized outside, return and **[Automatic] [Power exhaust] [Gravity]** relief dampers with spring return damper operator and control package to automatically vary outside air quantity. Outside air and exhaust air dampers, normally closed.
- e. Tight-fitting parallel blade dampers with neoprene or suitable gaskets, synthetic bushings and 1% maximum leakage.
- f. Damper Operation: 24 V, spring return motor with gear train sealed in oil.
- g. Mixed Air Controls: **[Maintain 55 degrees F (13 degrees C)] [Indicated]** mixed air temperature (adjustable).
- h. Up to 2 stages of cooling from **[Thermostat] [External DDC controller]** without need for additional controls.
- i. Up to 3 stages of cooling when used with relay and **[3-stage thermostat] [DDC controller]**.
- j. Up to 4 stages of cooling standard with room sensor.

Specifier Note: Specify article "j" when used with Lennox L Connection Network Building Automation System.

- k. Up to 4 stages of cooling.
- l. To allow blower on delay of up to 60 seconds after cooling demand is received. Default value of zero.
- m. To allow blower off delay of up to 240 seconds after cooling demand has ended. Default value of zero.
- n. Minimum compressor on time of **[240]** seconds on 3-phase units, adjustable between 60 - 510 seconds.
- o. Minimum compressor off time of **[300]** seconds on single-phase units, adjustable from 60 - 510 seconds.
- p. Default maximum high pressure switch trip occurrence during cooling or dehumidification cycle of **[3]**. Trip occurrence limit adjustable from 1 - 8 occurrences. If maximum limit reached, compressor locked out and digital output for service activated.
- q. Default maximum low pressure switch trip occurrence during cooling or dehumidification cycle of **[3]**. Trip occurrence limit adjustable from 1 - 8 occurrences. If maximum limit reached, compressor locked out and digital output for service activated.
- r. Low pressure trip read delay of **[5]** minutes if compressor off time has been less than 4 hours and outdoor temperature is less than 70 degrees F (21 degrees C). Delay adjustable from 0 - 34 minutes. Temperature set point adjustable from 10 degrees F (-12 degrees C) to 100 degrees F (38 degrees C). Compressor off time adjustable from 1 - 6 hours.
- s. Low pressure trip read delay of **[15]** minutes if compressor off time has been 4 hours or greater and outdoor temperature is less than 70 degrees F (21 degrees C). Delay adjustable from 0 - 34 minutes. Temperature set point adjustable from 10 degrees F (-12 degrees C) to 100 degrees F (38 degrees C). Compressor off time adjustable from 1 - 6 hours.
- t. Low pressure trip read delay of **[2]** minutes if compressor off time has been less than 4 hours and outdoor temperature is 70 degrees F (21 degrees C) or greater. Delay adjustable from 0 - 34 minutes.
- u. Temperature set point adjustable from 10 degrees F (-12 degrees C) to 100 degrees F (38 degrees C). Compressor off time adjustable from 1 - 6 hours.
- v. Low pressure trip read delay of **[8]** minutes if compressor off time has been 4 hours or greater and outdoor temperature is 70 degrees F (21 degrees C) or greater. Delay adjustable from 0 - 34 minutes.
- w. Temperature set point adjustable from 10 degrees F (-12 degrees C) to 100 degrees F (38 degrees C). Compressor off time adjustable from 1 - 6 hours.
- x. Each pressure switch trip occurrence (either high or low) to record error in nonvolatile memory and identify compressor circuit.
- y. Low outdoor air temperature compressor lockout set point of 0 degrees F (-18 degrees C) for each compressor circuit. Low outdoor temperature limit set point individually adjustable for each compressor circuit from 80 degrees F (27 degrees C) to -30 degrees F (-34 degrees C).
- z. Maximum allowable evaporator freeze-stat trip occurrence of **[3]** during cooling demand with limit adjustable from 1 - 4 occurrences. Control to shut off compressor each time freeze-stat trip occurs and record error code in nonvolatile memory. If maximum limit reached, compressor locked out and digital output for service activated.
- aa. Condenser Fan Control:
 - 1) On units with multiple condenser fans, **[6]** second time delay between condenser fan shutoff and restart to prevent reverse rotation of fan. Time delay adjustable between 0 - 16 seconds.
 - 2) On units with 4 condenser fans, first stage low outdoor temperature set point of 55 degrees F (13 degrees C) that reduces airflow through condenser by turning off some fans. Set point adjustable between 60 degrees F (16 degrees C) and 10 degrees F (-12 degrees C).

GUIDE SPECIFICATIONS

- 3) On units with 6 condenser fans, second stage low outdoor temperature set point of 40 degrees F (4 degrees C) to reduce airflow through condenser by turning off all fans. Set point adjustable between 60 degrees F (16 degrees C) and 10 degrees F (-12 degrees C).
- 4) On units with 6 condenser fans, condenser fan on delay of **[2]** seconds. Adjustable between 0 - 240 seconds.

Specifier Note: Edit article below to suit project requirements. If substitutions are permitted, edit text below. Add text to refer to Division 1 Project Requirements (Product Substitutions Procedures) Section.

PART 2.02 PRODUCT SUBSTITUTIONS

- A. Substitutions: No substitutions permitted.

PART 3 EXECUTION

PART 3.01 MANUFACTURER'S INSTRUCTIONS

Specifier Note: Article below is an addition to the CSI SectionFormat and a supplement to MANU-SPEC. Revise article below to suit project requirements and specifier's practice.

- A. Compliance: Comply with manufacturer's written data, including product technical bulletins, product catalog installation instructions, and product carton installation instructions.

PART 3.02 EXAMINATION

- A. Site Verification of Conditions: Verify substrate conditions, which have been previously installed under other sections, are acceptable for product installation in accordance with manufacturer's instructions.

PART 3.03 INSTALLATION

- A. Install **[Packaged rooftop units] [And] [Commercial packaged, gas/electric and electric/electric heat pumps]** in accordance with manufacturer's instructions, on roof curbs **[Provided by manufacturer] [As indicated]**.
- B. Run drain line from cooling coil condensation drain pan to discharge **[Over roof drain]**.

PART 3.04 COMPLETION AND CLEANUP

- A. Upon completion and verification of performance of installation, remove surplus materials, excess materials, rubbish, tools and equipment.

END OF SECTION

AFTERMARKET ZONING SYSTEM INTERFACE

Introduction

Lennox' seventh generation premium rooftop unit (RTU) controller, the Integrated Modular Controller (IMC) version M1-7, along with a variable frequency drive (VFD) option on certain L Series[®] and S-Class[™] RTUs, increases the ability of premium Lennox RTUs to be applied to a variety of zoning systems. The type of zoning system to be used dictates the type of RTU and the requirements for the zoning control system. The following explains each basic system and how the IMC must interface with an aftermarket zoning control system to meet the requirements of each application.

Lennox units in single zone and constant volume bypass applications may utilize an aftermarket unit controller as supervisory controller for the RTU. The IMC runs in thermostat mode and is primarily useful for diagnostic purposes, allowing the aftermarket controller to directly monitor and control heat/cool staging, the bypass damper, zone dampers, etc. When the IMC is used in thermostat mode, a maximum of two stage heating and three stage cooling are available.

Supervisory control must be provided by the Lennox IMC to minimize complication and standardize control on Lennox VFD-controlled variable air volume (VAV) RTUs. In this configuration, the IMC controls the VFD based on static pressure in the supply duct. It controls the economizer, and stages compressors based on discharge air temperature. The aftermarket controller simply sends calls for cooling or heating based on setpoint and schedule conditions. The IMC also has many options for controlling single-stage, 50% power exhaust fans; two-stage, 100% Power exhaust fans; or modulating power exhaust fans.

NOTE - Please refer to the IMC Manual (M1-7 Version 5.0x) for additional details.

Interface Definition

With an aftermarket control system interface, the IMC requires four digital inputs to control the rooftop unit: G (blower enable), OCP (occupied), Y1 (enables discharge cooling), W1 (enables discharge heating) and Y2 (second stage call for cooling) and W2 (second stage call for heating) should be added in constant volume applications.

These configurations minimize the controls expertise required to create a viable interface. Further, they create a consistent, standardized approach conducive to support and trouble-shooting on a broad basis without the need for substantial knowledge of the IMC, VFD, bypass, or aftermarket controllers or systems.

AFTERMARKET ZONING SYSTEM INTERFACE

Constant Volume Bypass RTU Wiring Summary for units equipped with M1-6 or M1-7 (Aftermarket Supervisory Control)

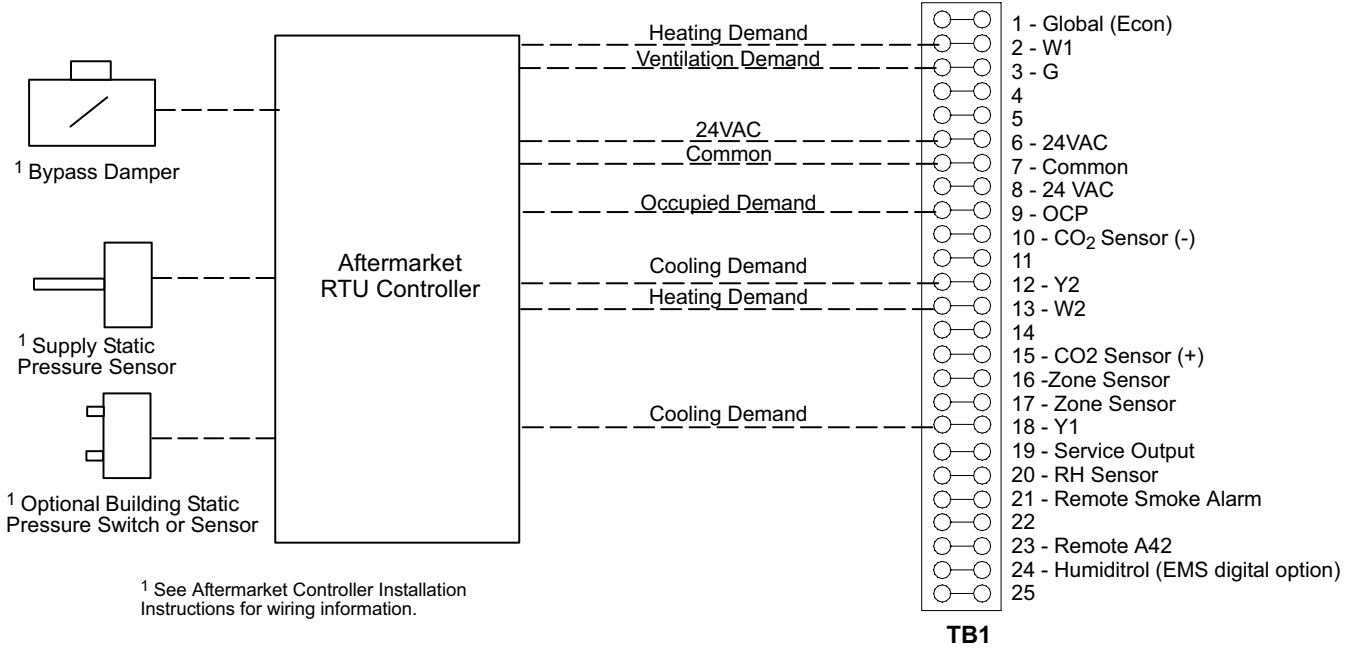

Variable Air Volume RTU Wiring Summary - for units equipped with M1-7 (IMC Supervisory Control)

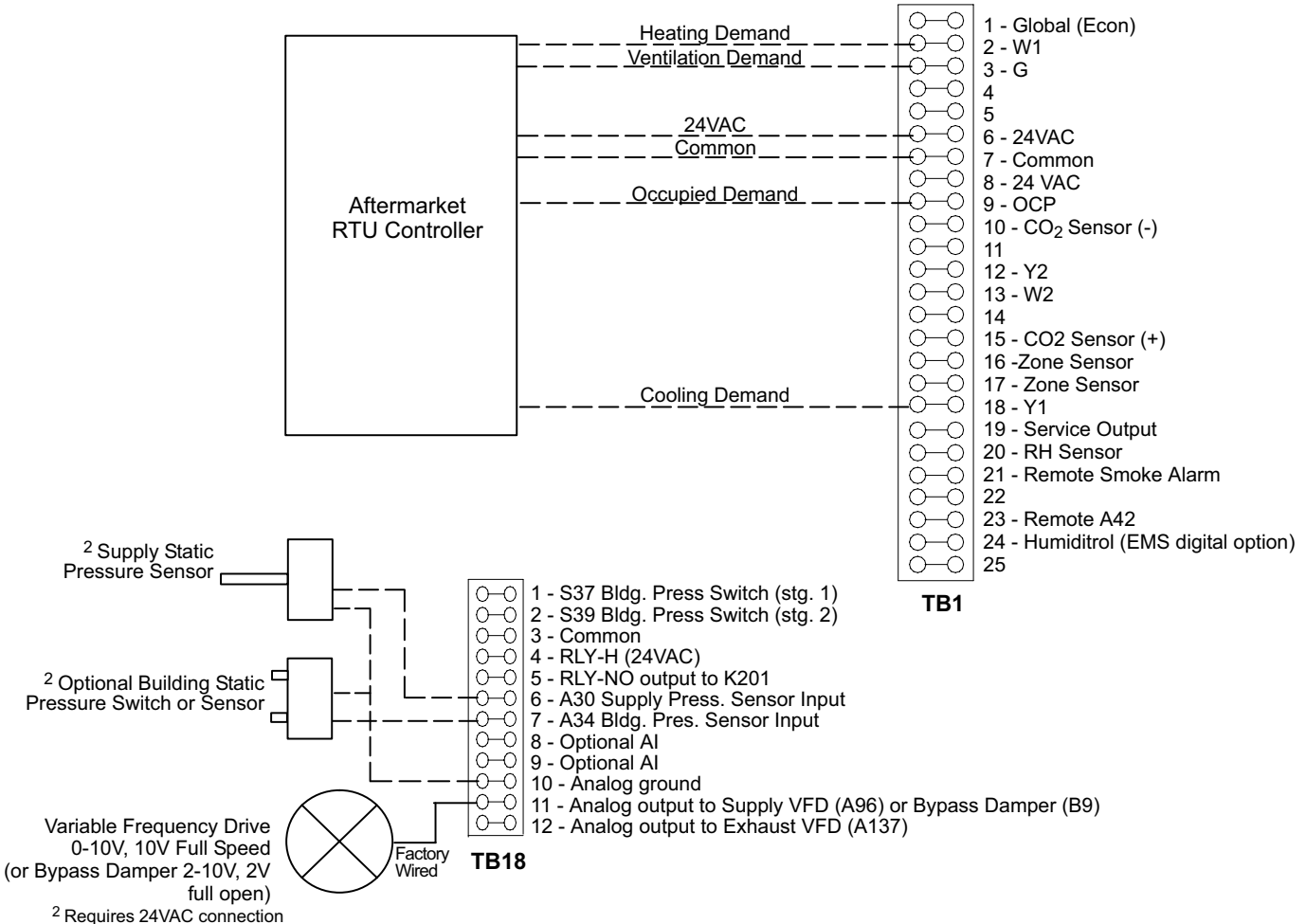

AFTERMARKET ZONING SYSTEM INTERFACE

Sequence of Operation **IMC Supervisory Control**

Operation when IMC blower (G) input is energized

When a G signal is present, the IMC controls the VFD or bypass damper to hold a constant supply duct static pressure based on the input from the IMC pressure sensor, using a PID control loop. For increased flexibility, the IMC has separate, adjustable static pressure setpoints for ventilation, cooling, heating and smoke alarms. These set points reside in the memory of the IMC, have factory default settings, and may be adjusted in the field prior to start-up.

Operation when IMC occupied (OCP) input is energized

When an OCP signal is present, the IMC adjusts the fresh air damper to either a fixed minimum position or allows it to modulate based on a CO₂ sensor. The CO₂ sensor can be wired directly to the IMC, to another controller that can monitor the sensor and pass a signal to the IMC for damper control, or to both the IMC and another device for monitoring through the desired man-machine interface while the IMC maintains damper control. During morning warm-up/cool-down the IMC keeps the fresh air damper closed based on the IMC configuration settings selected. The set points for minimum and maximum damper position setting and CO₂ control reside in the memory of the IMC, have factory default settings, and may be adjusted at start up. They cannot be adjusted using the aftermarket controls system.

Operation when IMC first stage cooling (Y1) input is energized

When a Y1 signal is present the IMC controls up to 4 stages of cooling (depending on RTU configuration) to maintain a cooling discharge air temperature setpoint. These stages include mechanical cooling, or outdoor air for cooling with an economizer. The discharge air temperature setpoint resides in the IMC, has a factory default setting, and may be adjusted at start up. It cannot be adjusted using the aftermarket controls system. The IMC has advanced discharge-air cooling reset options selected at start up based on return air temperature and/or outside air temperature. Outside air reset saves energy by gradually increasing the discharge air set point as outside air temperature decreases. Return air reset reduces potential for overcooling if the zoning system is misapplied, has an abnormal condition, or a dominant zone. The reset gradually increases discharge air temperature as return air temperature decreases.

NOTE - Y2 signal is recommended for constant volume applications.

Operation when IMC first stage heating (W1) input is energized

When a W1 signal is present, the IMC controls up to 4 stages of heating (depending on RTU configuration) to maintain a heating discharge air temperature. The heating discharge air temperature set point resides in the IMC, has a factory default setting, and may be adjusted at start up. It cannot be adjusted using the aftermarket controls system. The IMC has advanced discharge air heating reset options based on return air temperature and/or outside air temperature. Outside air reset saves energy by gradually decreasing the discharge air set point as outside air temperature increases. Return air reset reduces the potential for overheating if the zoning system is misapplied, has an abnormal condition, or a dominant zone. The reset gradually decreases discharge air temperature as return air temperature increases.

NOTE - W2 signal is recommended for constant volume applications.

Power Exhaust Fan Operation

The IMC has many power exhaust fan control options that include single-stage, two-stage and modulating control, depending on how the unit is equipped. Stage control options can be triggered based on fresh air damper positions, pressure switches, or a analog pressure sensor. Modulating control for units with VFD powered exhaust fans are typically modulated to maintain return or building static pressure, but can be staged. Set-points and operation settings for controlling power exhaust fans reside in the IMC, have factory default settings, and may be adjusted at start up. They cannot be adjusted using the aftermarket controls system.

REVISIONS

Sections	Description of Change
Document	Efficiency upgrade for all High Efficiency R-410A models. Updated specifications, cooling rating table, Humiditrol rating tables, electrical data
Blower Data	Added Drive Kit table, revised blower performance tables. Added Optional Air Resistance for MERV 11 and MERV 15 Filter options. Revised air resistance for Heat Exchangers.
Options/Accessories	Added MERV 11 and MERV 15 Filter options.
Sound Data	Sound Data table revised.
Weight Data	Revised corner weights.



VERIFIED
ENERGY
PERFORMANCE



VERIFIE
RENDEMENT
ENERGETIQUE



Visit us at www.lennox.com
For the latest technical information, www.lennoxcommercial.com
Contact us at 1-800-4-LENNOX

NOTE - Due to Lennox' ongoing commitment to quality, Specifications, Ratings and Dimensions subject to change without notice and without incurring liability. Improper installation, adjustment, alteration, service or maintenance can cause property damage or personal injury. Installation and service must be performed by a qualified installer and servicing agency.

©2007 Lennox Industries Inc.