

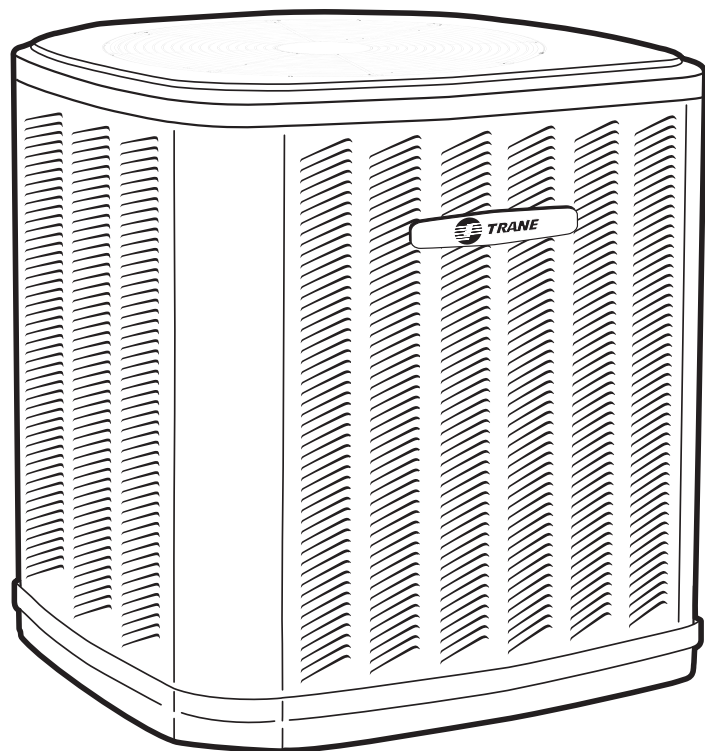

Split System Cooling Product Data

**Three Phase
4TTA3**

2½ – 5 Tons



PUB. NO. 22-1791-12



Features and Benefits

- All aluminum **Spine Fin™** coil
- **WeatherGuard™** fasteners
- **Quick-Sess™** cabinet, service access and refrigerant connections with full coil protection
- **DuraTuff™** base, fast complete drain, weatherproof
- **Comfort "R"™** mode approved
- Glossy corrosion resistant finish
- Internal compressor high/low pressure and temperature protection
- Liquid line filter-drier
- Polyslate gray cabinet with anthracite gray badge and cap
- R-410A refrigerant
- Low Pressure Switch
- High Pressure Switch
- Compressor Sump Heat
- S.E.E.T. design testing
- 100% line run test
- Low ambient cooling to 55°F as shipped
- Low ambient cooling to 30°F with AY28X079
- Low ambient cooling to 0°F with BAYLOAM103
- **Extended warranties available**

Contents

Features and Benefits	2
General Data	4
Product Specifications	4
A-Weighted Sound Power Level [dB(A)]	4
Accessory Description and Usage	5
AHRI Standard Capacity Rating Conditions	5
Model Nomenclature	7
Electrical Data	8
Dimensions	12
Mechanical Specification Options	14



General Data

CU-2

Product Specifications

Model No. ①	4TTA3030A3	4TTA3030A4	4TTA3036B3	4TTA3036B4
Electrical Data V/Ph/Hz ②	200/230/3/60	460/3/60	200/230/3/60	460/3/60
Min Cir Ampacity	10	5	14	8
Max Fuse Size (Amps)	15	15	20	15
Compressor	RECIP	RECIP	SCROLL	SCROLL
RL Amps - LR Amps	7.4 - 54.9	3.7 - 28	10.4 - 73	5.8 - 38
Outdoor Fan FL Amps	0.7	0.4	0.56	0.4
Fan HP	1/8	1/8	1/8	1/8
Fan Dia (inches)	23.0	23.0	23.0	23.0
Coil	Spine Fin™	Spine Fin™	Spine Fin™	Spine Fin™
Refrigerant R-410A	5/11-LB/OZ	5/11-LB/OZ	5/12-LB/OZ	5/12-LB/OZ
Line Size - (in.) O.D. Gas ③	3/4	3/4	3/4	3/4
Line Size - (in.) O.D. Liquid ③	3/8	3/8	3/8	3/8
Charge Spec. Subcooling	10°	10°	10°	10°
Dimensions H x W x D (Crated)	38 x 30.1 x 33	38 x 30.1 x 33	34 x 30.1 x 33	34 x 30.1 x 33
Weight - Shipping	224	222	176	176
Weight - Net	197	195	149	149
Start Components	NO	NO	NO	NO
Sound Enclosure	NO	NO	NO	NO
Compressor Sump Heat	YES	YES	YES	YES
Optional Accessories: ④				
Anti-short Cycle Timer	TAYASCT501A	TAYASCT501A	TAYASCT501A	TAYASCT501A
Evaporator Defrost Control	AY28X079	AY28X079	AY28X079	AY28X079
Rubber Isolator Kit	BAYISLT101	BAYISLT101	BAYISLT101	BAYISLT101
Snow/Sand Legs - Base & Cap 4" High	BAYLEGS002	BAYLEGS002	BAYLEGS002	BAYLEGS002
Snow/Sand Legs - 4" Extension	BAYLEGS003	BAYLEGS003	BAYLEGS003	BAYLEGS003
Indoor Fan Delay Kit	BAY24X045	BAY24X045	BAY24X045	BAY24X045
Sound Enclosure	BAYSDEN001	BAYSDEN001	BAYSDEN003	BAYSDEN003
Extreme Condition Mounting Kit	BAYECMT001	BAYECMT001	BAYECMT001	BAYECMT001
Seacoast Kit	BAYSEAC001	BAYSEAC001	BAYSEAC001	BAYSEAC001
Low Ambient Kit	BAYLOAM103	BAYLOAM103	BAYLOAM103	BAYLOAM103
Refrigerant Lineset ⑤	TAYREFLN2*	TAYREFLN2*	TAYREFLN7*	TAYREFLN7*

① Certified in accordance with the Unitary Air-Conditioner equipment certification program which is based on AHRI Standard 210/240.

② Calculated in accordance with N.E.C. Only use HACR circuit breakers or fuses.

③ Standard line lengths - 60'. Standard lift - 60' Suction and Liquid line.

For greater lengths and lifts refer to refrigerant piping software Pub# 32-3312-01. (*denotes latest revision)

④ For accessory description and usage, see page 5.

⑤ * = 15, 20, 25, 30, 40 and 50 foot lineset available.

A-Weighted Sound Power Level [dB(A)]

MODEL	SOUND POWER LEVEL [dB(A)]	A_WEIGHTED FULL OVTAVE SOUND POWER LEVEL dB - [dB(A)]							
		63	125	250	500	1000	2000	4000	8000
4TTA3030A3/4	78	49	60.2	66	70.3	71.4	69.8	60.4	53
4TTA3036B3/4	78	45.5	58.7	63.1	69.7	70	68.1	59	49.8
4TTA3042D3/4	79	47.5	64.5	67	75.3	74	70.7	62.2	52.8
4TTA3048D3/4	79	47.4	60	66.9	75.3	73.5	70.3	62	51.4
4TTA3060D3/4	80	47.3	55.7	69	72.7	75.8	69.4	62.2	53.3

Note: Rated in accordance with AHRI Standard 270-2008

General Data

Product Specifications

Model No. ①	4TTA3042D3	4TTA3042D4	4TTA3048D3	4TTA3048D4
Electrical Data V/Ph/Hz ②	208/230/3/60	460/3/60	208/230/3/60	460/3/60
Min Cir Ampacity	18	8	18	8
Max Fuse Size (Amps)	30	15	30	15
Compressor	SCROLL	SCROLL	SCROLL	SCROLL
RL Amps - LR Amps	13.6 - 83	6.4 - 41	13.7 - 83	6.4 - 41
Outdoor Fan FL Amps	1.2	0.6	1.2	0.6
Fan HP	1/5	1/5	1/5	1/5
Fan Dia (inches)	27.6	27.6	27.6	27.6
Coil	Spine Fin™	Spine Fin™	Spine Fin™	Spine Fin™
Refrigerant R-410A	6/2-LB/OZ	6/2-LB/OZ	6/13-LB/OZ	6/13-LB/OZ
Line Size - (in.) O.D. Gas ③	3/4	3/4	7/8	7/8
Line Size - (in.) O.D. Liquid ③	3/8	3/8	3/8	3/8
Charge Spec. Subcooling	10°	10°	10°	10°
Dimensions H x W x D (Crated)	34.4 x 35.1 x 38.7	38.4 x 35.1 x 38.7	34.4 x 35.1 x 38.7	38.4 x 35.1 x 38.7
Weight - Shipping	228	228	235	235
Weight - Net	196	196	203	203
Start Components	NO	NO	NO	NO
Sound Enclosure	NO	NO	NO	NO
Compressor Sump Heat	YES	YES	YES	YES
Optional Accessories: ④				
Anti-short Cycle Timer	TAYASCT501A	TAYASCT501A	TAYASCT501A	TAYASCT501A
Evaporator Defrost Control	AY28X079	AY28X079	AY28X079	AY28X079
Rubber Isolator Kit	BAYISLT101	BAYISLT101	BAYISLT101	BAYISLT101
Snow/Sand Legs - Base & Cap 4" High	BAYLEGS002	BAYLEGS002	BAYLEGS002	BAYLEGS002
Snow/Sand Legs - 4" Extension	BAYLEGS003	BAYLEGS003	BAYLEGS003	BAYLEGS003
Indoor Fan Delay Kit	BAY24X045	BAY24X045	BAY24X045	BAY24X045
Sound Enclosure	BAYSDEN003	BAYSDEN003	BAYSDEN003	BAYSDEN003
Extreme Condition Mounting Kit	BAYECMT001	BAYECMT001	BAYECMT001	BAYECMT001
Seacoast Kit	BAYSEAC001	BAYSEAC001	BAYSEAC001	BAYSEAC001
Low Ambient Kit	BAYLOAM103	BAYLOAM103	BAYLOAM103	BAYLOAM103
Refrigerant Lineset ⑤	TAYREFLN7*	TAYREFLN7*	TAYREFLN3*	TAYREFLN3

Accessory Description and Usage

Anti-Short Cycle Timer — Solid state timing device that prevents compressor recycling until five (5) minutes have elapsed after satisfying call or power interruptions. Use in area with questionable power delivery, commercial applications, long lineset, etc.

Evaporator Defrost Control — SPST Temperature actuated switch that cycles the condenser off as indoor coil reaches freeze-up conditions. Used for low ambient cooling to 30°F with TXV.

Rubber Isolators — Five (5) large rubber donuts to isolate condensing unit from transmitting energy into mounting frame or pad. Use on any application where sound transmission needs to be minimized.

Hard Start kit — Start capacitor and relay to assist compressor motor startup. Use in areas with marginal power supply, on long linesets, low ambient conditions, etc.

Extreme Condition Mount Kit — Bracket kits to securely mount condensing unit to a frame or pad without removing any panels. Use in areas with high winds, or on commercial roof tops, etc.

AHRI Standard Capacity Rating Conditions

AHRI STANDARD 210/240 RATING CONDITIONS —

- (A) Cooling 80°F DB, 67°F WB air entering indoor coil, 95°F DB air entering outdoor coil.
- (B) High Temperature Heating 47°F DB, 43°F WB air entering outdoor coil, 70°F DB air entering indoor coil.
- (C) Low Temperature Heating 17°F DB, 15°F WB air entering outdoor coil, 70°F DB air entering indoor coil.
- (D) Rated indoor airflow for heating is the same as for cooling.

AHRI STANDARD 270 RATING CONDITIONS — (Noise rating numbers are determined with the unit in cooling operation.) Standard Noise Rating number is at 95°F outdoor air.





General Data

Product Specifications

Model No. ^①	4TTA3060D3	4TTA3060D4
Electrical Data V/Ph/Hz ^②	208/230/3/60	460/3/60
Min Cir Ampacity	21	10
Max Fuse Size (Amps)	35	15
Compressor	SCROLL	SCROLL
RL Amps - LR Amps	15.6 - 110	7.8 - 52
Outdoor Fan FL Amps	1.2	0.6
Fan HP	1/5	1/5
Fan Dia (inches)	27.6	27.6
Coil	Spine Fin™	Spine Fin™
Refrigerant R-410A	8/00-LB/OZ	8/00-LB/OZ
Line Size - (in.) O.D. Gas ^③	7/8	7/8
Line Size - (in.) O.D. Liquid ^③	3/8	3/8
Charge Spec. Subcooling	10°	10°
Dimensions H x W x D (Crated)	42.4 x 35.1 x 38.7	42.4 x 35.1 x 38.7
Weight - Shipping	261	261
Weight - Net	226	226
Start Components	NO	NO
Sound Enclosure	NO	NO
Compressor Sump Heat	YES	YES
Optional Accessories: ^④		
Anti-short Cycle Timer	TAYASCT501A	TAYASCT501A
Evaporator Defrost Control	AY28X079	AY28X079
Rubber Isolator Kit	BAYISLT101	BAYISLT101
Snow/Sand Legs - Base & Cap 4" High	BAYLEGS002	BAYLEGS002
Snow/Sand Legs - 4" Extension	BAYLEGS003	BAYLEGS003
Indoor Fan Delay Kit	BAY24X045	BAY24X045
Sound Enclosure	BAYSDEN004	BAYSDEN004
Extreme Condition Mounting Kit	BAYECMT001	BAYECMT001
Seacoast Kit	BAYSEAC001	BAYSEAC001
Low Ambient Kit	BAYLOAM103	BAYLOAM103
Refrigerant Lineset ^⑤	TAYREFLN3*	TAYREFLN3*

^① Certified in accordance with the Unitary Air-Conditioner equipment certification program which is based on AHRI Standard 210/240.

^② Calculated in accordance with N.E.C. Only use HACR circuit breakers or fuses.

^③ Standard line lengths - 60'. Standard lift - 60' Suction and Liquid line.

For greater lengths and lifts refer to refrigerant piping software Pub# 32-3312-01. (*denotes latest revision)

^④ For accessory description and usage, see page 5.

^⑤ * = 15, 20, 25, 30, 40 and 50 foot lineset available.



Model Nomenclature

Outdoor Units

4TTA3036A3000AA

- Refrigerant Type**
 - 2 = R-22
 - 4 = R-410A
- TRANE**
- Product Type**
 - W = Split Heat Pump
 - T = Split Cooling
- Product Family**
 - Z = Leadership – Two Stage
 - X = Leadership
 - R = Replacement/Retail
 - B = Basic
 - A = Light Commercial
- Family SEER**
 - 0 = 10 3 = 13 6 = 16
 - 1 = 11 4 = 14 8 = 18
 - 2 = 12 5 = 15 9 = 19
- Split System Connections 1-6 Tons**
 - 0 = Brazed
- Nominal Capacity in 000s of BTUs**
- Major Design Modifications**
- Power Supply**
 - 1 = 200-230/1/60 or 208-230/1/60
 - 3 = 200-230/3/60
 - 4 = 460/3/60
- Secondary Function**
- Minor Design Modifications**
- Unit Parts Identifier**

High Efficiency Furnaces

TUD1B080A9H31AA

- Furnace Configuration**
 - TU = Upflow / Horizontal
 - TD = Downflow / Horizontal
- Type**
 - D = 80% Premium
 - X = 90% Premium
- Number of Heating Stages**
 - 1 = Single Stage
 - 2 = Two Stage
 - 3 = Three Stage
- Cabinet Width**
 - A = 14.5" Cabinet Width
 - B = 17.5" Cabinet Width
 - C = 21.0" Cabinet Width
 - D = 24.5" Cabinet Width
- Heating Input**
 - 080 = 80,000 BTUH
- Major Design Change**
- Power Supply / Fuel**
 - 9 = 115 Volts / Natural Gas
 - F = 115 Volts / Natural Gas with Integrated iFD Filter
- Airflow Capacity for Cooling**
 - 36 = 3 Ton Standard PSC Motor
 - H3 = 3 Ton High Efficiency Motor
 - V3 = 3 Ton Variable Speed Motor
- Draft Inducer Speeds**
 - 1 = Single Speed
 - 2 = Two Speed
 - V = Variable Speed
- Minor Design Change**
- Service Digit - Not Orderable**

Air Handlers-Residential

123456789101112131415

4TEE3F36A1000AA

- Refrigerant Type**
 - 4 = R-410A
- Application**
 - TE = Fully Convertible
 - TG = Semi Convertible
 - TF = Front Return
 - TB = Modular Blower
- Product Family**
 - E = Leadership - Variable Speed
 - H = High Efficiency
 - C = Replacement/Retail
 - B = Basic
- Flow Control**
 - 0 = No Flow Control
 - 3 = TXV-Non-bleed
- Feature Identifier**
 - 0 = Standard Unit
 - F = Air-Tite™
 - D = Intergated Whole Home Air Cleaner
 - C = Communicating Air Handler
- Nominal Capacity in 1000's (BTUH)**
- Major Design Change**
- Power Supply**
 - 1 = Single Phase
- Electrical Connection**
 - 0 = Pig Tails
 - B = Circuit Breaker
 - D = Pull Disconnect
- Future Option - Factory Installed Heater Nominal KW Value**
- Minor Design Change**
- Service Digit - Not Orderable**

Heat Pump / Cooling Coils

2TXCB036AC3HCA

- Refrigerant Type**
 - 2 = R-22 4 = R-410A
- Product Family**
 - T = Premium (Heat Pump or Convertible Coil)
 - C = Standard (Cooling Only)
- Coil Design**
 - X = Direct Expansion Evaporator Coil
- Product Family**
 - C = Cased A Coil
 - A = Uncased A Coil
 - F = Cased Horizontal Flat Coil
- Coil Width (Cased / Uncased)**
 - A = 14.5" / 13.3" C = 21.0" / 19.8" H = 10.5"
 - B = 17.5" / 16.3" D = 24.5" / 23.3"
- Refrigerant Line Coupling**
 - 0 = Brazed
- Nominal Capacity in 000s of BTUs**
- Major Design Change**
- Efficiency**
 - C = Standard S = Hi Efficiency
- Refrigerant Control**
 - 3 = TXV - Non-Bleed
- Coil Circuitry**
 - H = Heat Pump
 - C = Cooling Only
- Airflow Configuration**
 - A = Upflow Only
 - U = Upflow / Downflow
 - H = Horizontal Only
 - C = Convertible – Upflow, Downflow, Left Airflow
 - M = Convertible – Upflow, Downflow, Left or Right Airflow
- Minor Design Change**
- Unit Parts Identifier**



Electrical Data

Schematic Diagrams

(SEE LEGEND)

4TTA3030A3

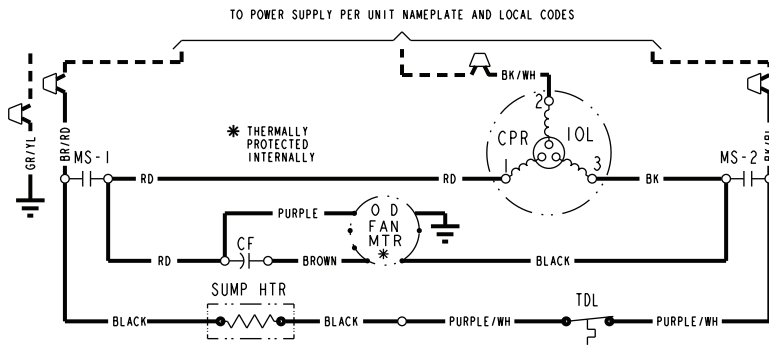

CA COOLING ANTICIPATOR	LPCO LOW PRESSURE CUTOFF SW.
CBS COIL BOTTOM SENSOR	MS COMPRESSOR MOTOR CONTACTOR
CF FAN CAPACITOR	ODA OUTDOOR ANTICIPATOR
CN WIRE CONNECTOR	OFT OUTDOOR FAN THERMOSTAT
CPR COMPRESSOR	ODS OUTDOOR TEMPERATURE SENSOR
CR RUN CAPACITOR	ODT OUTDOOR THERMOSTAT
CS STARTING CAPACITOR	RHS RESISTANCE HEAT SWITCH
CSR CAPACITOR SWITCHING RELAY	SC SWITCHOVER VALVE SOLENOID
DFC DEFROST CONTROL	SM SYSTEM "ON-OFF" SWITCH
F INDOOR FAN RELAY	TDL DISCHARGE LINE THERMOSTAT
HA HEATING ANTICIPATOR	TNS TRANSFORMER
HPCO HIGH PRESSURE CUTOFF SW.	TS HEATING-COOLING THERMOSTAT
IOL INTERNAL OVERLOAD PROTECTOR	TSH HEATING THERMOSTAT

<p>⚠ WARNING HAZARDOUS VOLTAGE! DISCONNECT ALL ELECTRIC POWER INCLUDING REMOTE DISCONNECTS BEFORE SERVICING. FAILURE TO DISCONNECT POWER BEFORE SERVICING CAN CAUSE SEVERE PERSONAL INJURY OR DEATH!</p>	<p>⚠ CAUTION USE COPPER CONDUCTORS ONLY! UNIT TERMINALS ARE NOT DESIGNED TO ACCEPT OTHER TYPES OF CONDUCTORS. FAILURE TO DO SO MAY CAUSE DAMAGE TO THE EQUIPMENT!</p>
---	--

COLOR OF WIRE			
BK/BL	BLACK WIRE WITH BLUE MARKER		
COLOR OF MARKER			
BK	BLACK	OR	ORANGE
BL	BLUE	RD	RED
BR	BROWN	WH	WHITE
		YL	YELLOW
		GR	GREEN
		PR	PURPLE

NOTES:

1. IF ODT-B IS NOT USED, ADD JUMPER BETWEEN W2 & W3 AT AIR HANDLER.
IF USED, ODT-B MUST BE MOUNTED REMOTE OF CONTROL BOX IN AN APPROVED WEATHER PROOF ENCLOSURE.
2. IF ODT-A IS NOT USED, ADD JUMPER BETWEEN W1 & W2 AT AIR HANDLER.
3. LOW VOLTAGE (24 V.) FIELD WIRING MUST BE 18 AWG MIN.

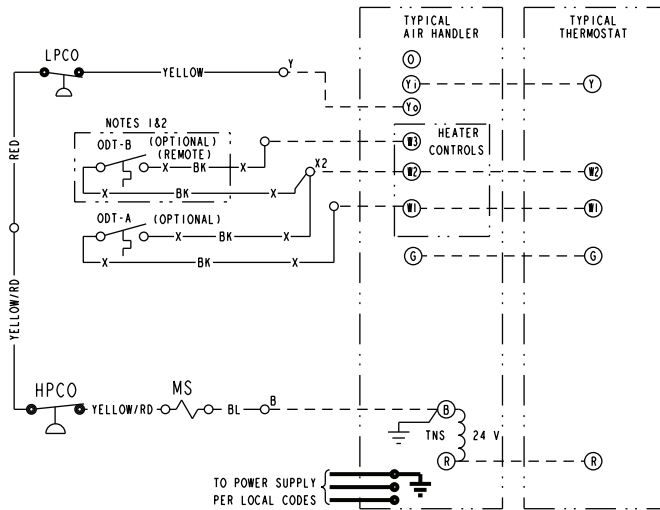

NOTE
THREE PHASE MOTOR (S) FACTORY SUPPLIED IN THIS EQUIPMENT PROTECTED UNDER PRIMARY SINGLE-PHASE CONDITIONS.

PRINTED FROM D157074P01

Electrical Data

Schematic Diagrams (SEE LEGEND)

4TTA3030A4, 4TTA3036B4

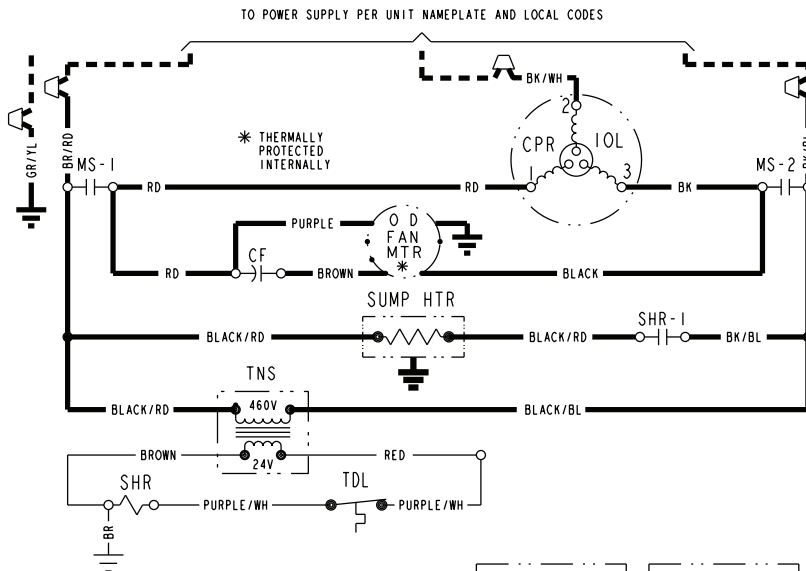

CA	COOLING ANTICIPATOR	LPCO	LOW PRESSURE CUTOFF SW.
CBS	COIL BOTTOM SENSOR	MS	COMPRESSOR MOTOR CONTACTOR
CF	FAN CAPACITOR	ODA	OUTDOOR ANTICIPATOR
CN	WIRE CONNECTOR	OFI	OUTDOOR FAN THERMOSTAT
CPR	COMPRESSOR	ODS	OUTDOOR FAN TEMPERATURE SENSOR
CR	RUN CAPACITOR	ODT	OUTDOOR THERMOSTAT
CS	STARTING CAPACITOR	RHS	RESISTANCE HEAT SWITCH
CSR	CAPACITOR SWITCHING RELAY	SC	SWITCHOVER VALVE SOLENOID
DFC	DEFROST CONTROL	SHR	SUMP HEAT RELAY
F	INDOOR FAN RELAY	SM	SYSTEM "ON-OFF" SWITCH
HA	HEATING ANTICIPATOR	TDL	DISCHARGE LINE THERMOSTAT
HPCO	HIGH PRESSURE CUTOFF SW.	TNS	TRANSFORMER
IOL	INTERNAL OVERLOAD PROTECTOR	TS	HEATING-COOLING THERMOSTAT
		TSH	HEATING THERMOSTAT

⚠ WARNING	⚠ CAUTION
HAZARDOUS VOLTAGE! DISCONNECT ALL ELECTRIC POWER INCLUDING REMOTE DISCONNECTS BEFORE SERVICING.	USE COPPER CONDUCTORS ONLY! UNIT TERMINALS ARE NOT DESIGNED TO ACCEPT OTHER TYPES OF CONDUCTORS.
FAILURE TO DISCONNECT POWER BEFORE SERVICING CAN CAUSE SEVERE PERSONAL INJURY OR DEATH!	FAILURE TO DO SO MAY CAUSE DAMAGE TO THE EQUIPMENT!

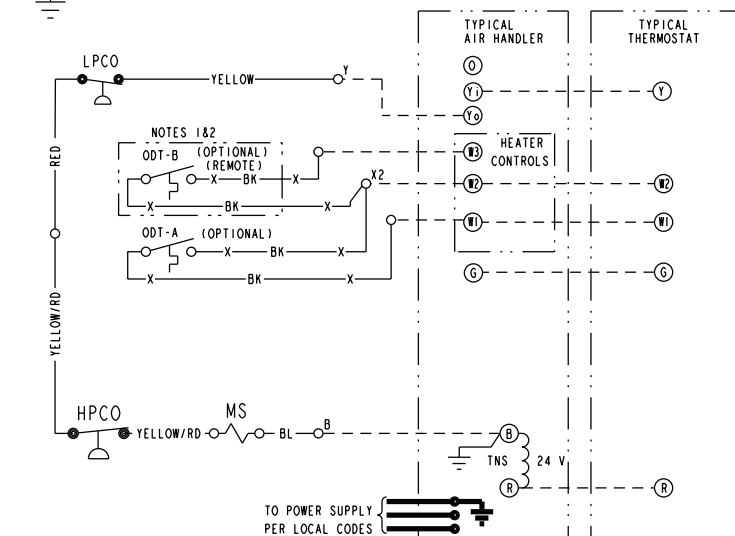

COLOR OF WIRE
BK/BL BLACK WIRE WITH BLUE MARKER
COLOR OF MARKER

BK	BLACK	OR	ORANGE	YL	YELLOW
BL	BLUE	RD	RED	GR	GREEN
BR	BROWN	WH	WHITE	PR	PURPLE

NOTES:

- IF ODT-B IS NOT USED, ADD JUMPER BETWEEN W2 & W3 AT AIR HANDLER. IF USED, ODT-B MUST BE MOUNTED REMOTE OF CONTROL BOX IN AN APPROVED WEATHER PROOF ENCLOSURE.
- IF ODT-A IS NOT USED, ADD JUMPER BETWEEN W1 & W2 AT AIR HANDLER.
- LOW VOLTAGE (24 V.) FIELD WIRING MUST BE 18 AWG MIN.

NOTE
THREE PHASE MOTOR (S) FACTORY SUPPLIED IN THIS EQUIPMENT PROTECTED UNDER PRIMARY SINGLE-PHASE CONDITIONS.



Electrical Data

Schematic Diagrams

(SEE LEGEND)

4TTA3036B3, 4TTA3042D3, 4TTA3048D3, 4TTA3060D3

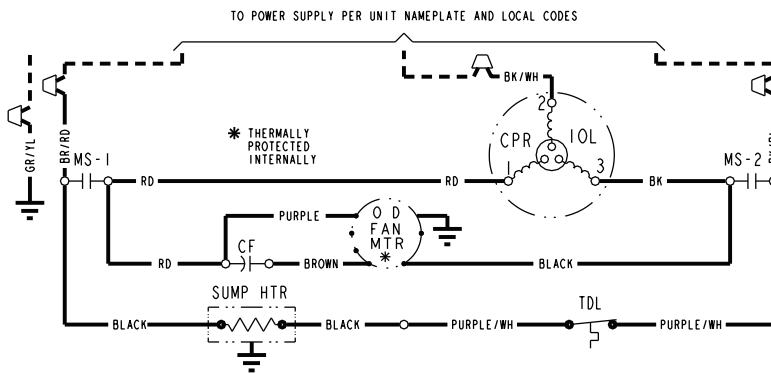

CA COOLING ANTICIPATOR	LPCO LOW PRESSURE CUTOFF SW.
CBS COIL BOTTOM SENSOR	MS COMPRESSOR MOTOR CONTACTOR
CF FAN CAPACITOR	ODA OUTDOOR ANTICIPATOR
CN WIRE CONNECTOR	OFT OUTDOOR FAN THERMOSTAT
CPR COMPRESSOR	ODS OUTDOOR TEMPERATURE SENSOR
CR RUN CAPACITOR	ODT OUTDOOR THERMOSTAT
CS STARTING CAPACITOR	RHS RESISTANCE HEAT SWITCH
CSR CAPACITOR SWITCHING RELAY	SC SWITCHOVER VALVE SOLENOID
DFC DEFROST CONTROL	SM SYSTEM "ON-OFF" SWITCH
F INDOOR FAN RELAY	TDL DISCHARGE LINE THERMOSTAT
HA HEATING ANTICIPATOR	TNS TRANSFORMER
HPCO HIGH PRESSURE CUTOFF SW.	TS HEATING-COOLING THERMOSTAT
IOL INTERNAL OVERLOAD PROTECTOR	TSH HEATING THERMOSTAT

⚠ WARNING	⚠ CAUTION
HAZARDOUS VOLTAGE! DISCONNECT ALL ELECTRIC POWER INCLUDING REMOTE DISCONNECTS BEFORE SERVICING. FAILURE TO DISCONNECT POWER BEFORE SERVICING CAN CAUSE SEVERE PERSONAL INJURY OR DEATH!	USE COPPER CONDUCTORS ONLY! UNIT TERMINALS ARE NOT DESIGNED TO ACCEPT OTHER TYPES OF CONDUCTORS. FAILURE TO DO SO MAY CAUSE DAMAGE TO THE EQUIPMENT!

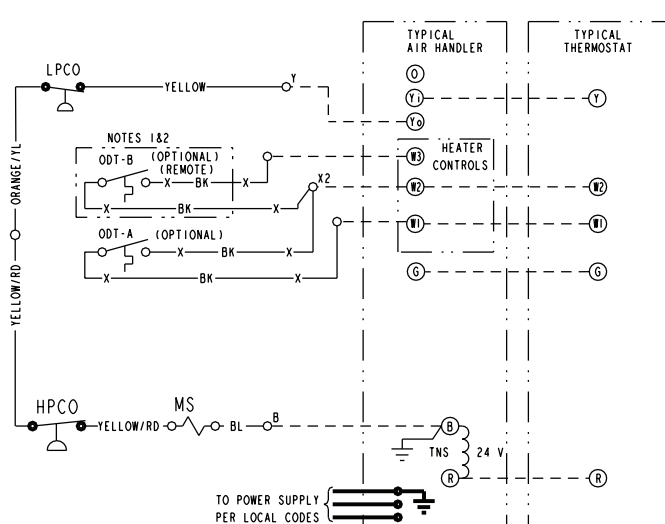

—	COLOR OF WIRE				
BK/BL	BLACK WIRE WITH BLUE MARKER				
—	COLOR OF MARKER				
BK	BLACK	OR	ORANGE	YL	YELLOW
BL	BLUE	RD	RED	GR	GREEN
BR	BROWN	WH	WHITE	PR	PURPLE

NOTES:

- IF ODT-B IS NOT USED, ADD JUMPER BETWEEN W2 & W3 AT AIR HANDLER. IF USED, ODT-B MUST BE MOUNTED REMOTE OF CONTROL BOX IN AN APPROVED WEATHER PROOF ENCLOSURE.
- IF ODT-A IS NOT USED, ADD JUMPER BETWEEN W1 & W2 AT AIR HANDLER.
- LOW VOLTAGE (24 V.) FIELD WIRING MUST BE 18 AWG MIN.

NOTE
THREE PHASE MOTOR (S) FACTORY SUPPLIED IN THIS EQUIPMENT PROTECTED UNDER PRIMARY SINGLE-PHASE CONDITIONS.

PRINTED FROM D157062P02

Electrical Data

Schematic Diagrams (SEE LEGEND)

4TTA3042D4, 4TTA3048D4, 4TTA3060D4

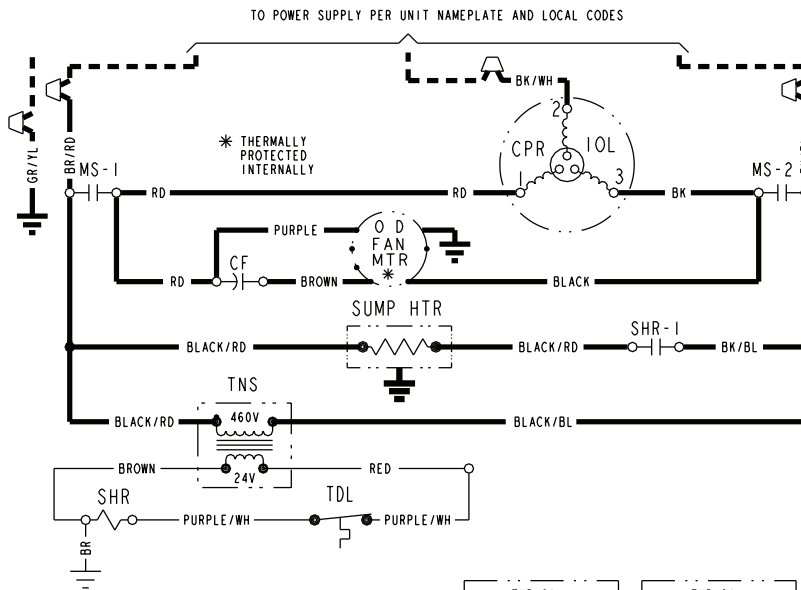

- | | | | |
|------|-----------------------------|------|----------------------------|
| CA | COOLING ANTICIPATOR | LPCO | LOW PRESSURE CUTOUT SW. |
| CBS | COIL BOTTOM SENSOR | MS | COMPRESSOR MOTOR CONTACTOR |
| CF | FAN CAPACITOR | ODA | OUTDOOR ANTICIPATOR |
| CN | WIRE CONNECTOR | OFT | OUTDOOR FAN THERMOSTAT |
| CPR | COMPRESSOR | ODS | OUTDOOR TEMPERATURE SENSOR |
| CR | RUN CAPACITOR | ODT | OUTDOOR THERMOSTAT |
| CS | STARTING CAPACITOR | RHS | RESISTANCE HEAT SWITCH |
| CSR | CAPACITOR SWITCHING RELAY | SC | SWITCHOVER VALVE SOLENOID |
| DFC | DEFROST CONTROL | SHR | SUMP HEAT RELAY |
| F | INDOOR FAN RELAY | SM | SYSTEM "ON-OFF" SWITCH |
| HA | HEATING ANTICIPATOR | TDL | DISCHARGE LINE THERMOSTAT |
| HPCO | HIGH PRESSURE CUTOUT SW. | TNS | TRANSFORMER |
| IOL | INTERNAL OVERLOAD PROTECTOR | TS | HEATING-COOLING THERMOSTAT |
| | | TSH | HEATING THERMOSTAT |

<p>⚠ WARNING HAZARDOUS VOLTAGE! DISCONNECT ALL ELECTRIC POWER INCLUDING REMOTE DISCONNECTS BEFORE SERVICING. FAILURE TO DISCONNECT POWER BEFORE SERVICING CAN CAUSE SEVERE PERSONAL INJURY OR DEATH!</p>	<p>⚠ CAUTION USE COPPER CONDUCTORS ONLY! UNIT TERMINALS ARE NOT DESIGNED TO ACCEPT OTHER TYPES OF CONDUCTORS. FAILURE TO DO SO MAY CAUSE DAMAGE TO THE EQUIPMENT!</p>
---	--

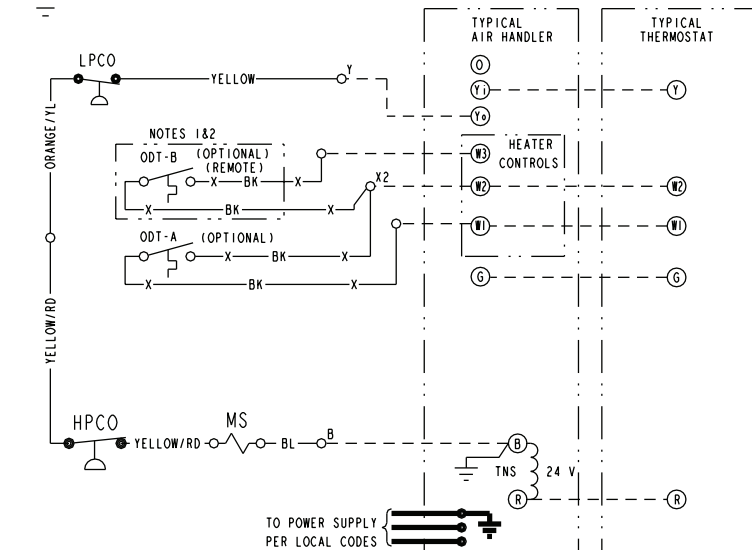

- COLOR OF WIRE
- BK/BL BLACK WIRE WITH BLUE MARKER
- COLOR OF MARKER
- | | | | | | |
|----|-------|----|--------|----|--------|
| BK | BLACK | OR | ORANGE | YL | YELLOW |
| BL | BLUE | RD | RED | GR | GREEN |
| BR | BROWN | WH | WHITE | PR | PURPLE |

NOTES:

- IF ODT-B IS NOT USED, ADD JUMPER BETWEEN W2 & W3 AT AIR HANDLER.
IF USED, ODT-B MUST BE MOUNTED REMOTE OF CONTROL BOX IN AN APPROVED WEATHER PROOF ENCLOSURE.
- IF ODT-A IS NOT USED, ADD JUMPER BETWEEN W1 & W2 AT AIR HANDLER.
- LOW VOLTAGE (24 V.) FIELD WIRING MUST BE 18 AWG MIN.

NOTE
THREE PHASE MOTOR (S) FACTORY SUPPLIED IN THIS EQUIPMENT PROTECTED UNDER PRIMARY SINGLE-PHASE CONDITIONS.

Dimensions

4TTA3 Outline Drawing

NOTE: ALL DIMENSIONS ARE IN MM (INCHES)

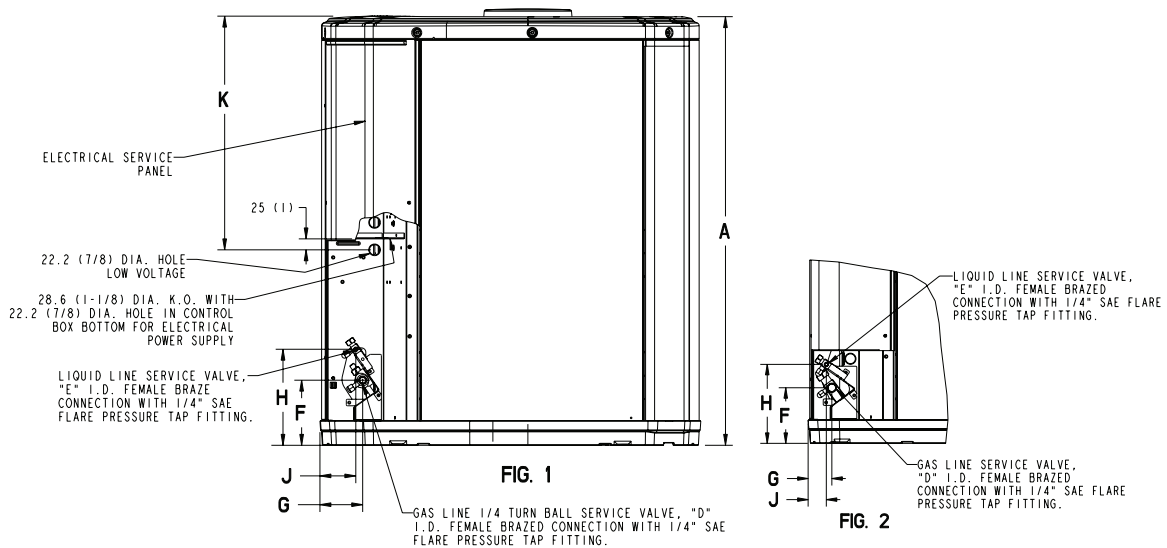
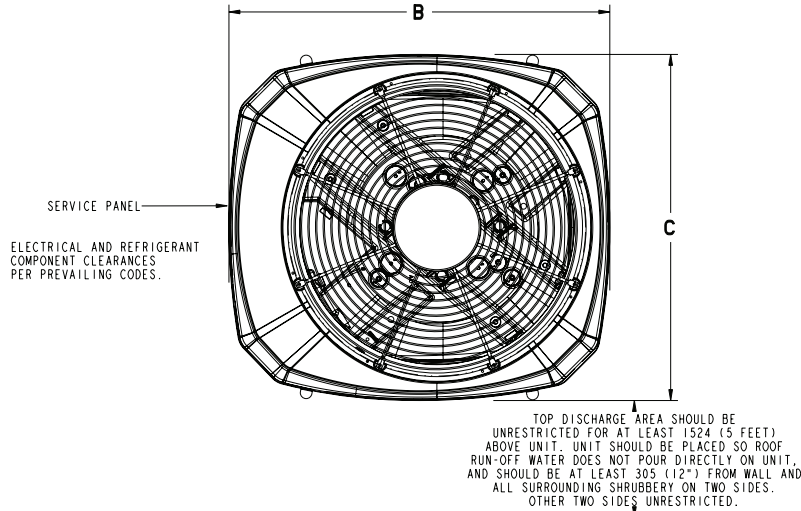

MODELS	BASE	FIG.	A	B	C	D	E	F	G	H	J	K
4TTA3030A	3	1	832 (32-3/4)	829 (32-5/8)	756 (29-3/4)	3/4	3/8	143 (5-5/8)	92 (3-5/8)	210 (8-1/4)	79 (3-1/8)	508 (20)
4TTA3036B	3	1	733 (28-3/4)	829 (32-5/8)	756 (29-3/4)	3/4	3/8	137 (5-3/8)	79 (3-1/8)	197 (7-3/4)	60 (2-3/8)	508 (20)
4TTA3042D	4	1	741 (29-1/8)	946 (37-1/4)	870 (34-1/4)	3/4	3/8	152 (6)	98 (3-7/8)	219 (8-5/8)	86 (3-3/8)	508 (20)
4TTA3048D	4	1	741 (29-1/8)	946 (37-1/4)	870 (34-1/4)	7/8	3/8	152 (6)	98 (3-7/8)	219 (8-5/8)	86 (3-3/8)	508 (20)
4TTA3060D	4	1	943 (37-1/8)	946 (37-1/4)	870 (34-1/4)	7/8	3/8	152 (6)	98 (3-7/8)	219 (8-5/8)	86 (3-3/8)	508 (20)

FROM DWG. D153074



Mechanical Specification Options

General

The 4TTA3 shall be fully charged from the factory for matched indoor section and up to 15 feet of piping. This unit must be designed to operate at outdoor ambient temperatures as high as 115°F. Cooling capacities shall be matched with a wide selection of air handlers and furnace coils that are AHRI certified. The unit is certified to UL 1995 application.

Casing

Unit casing is constructed of heavy gauge, galvanized steel and painted with a weather-resistant powder paint. Corrosion and weatherproof CMBP-G30 base.

Refrigerant Controls

Refrigeration system controls include condenser fan and compressor contactor. High and low pressure controls are inherent to the compressor. Another standard feature is the liquid line dryer.

Compressor

The compressor features internal over temperature and pressure protector, total dipped hermetic motor and thermostatically controlled sump heater. Other features include: roto lock suction and discharge refrigeration connections, centrifugal oil pump, and low vibration and noise.

Condenser Coil

The Spine Fin™ coil shall be continuously wrapped, corrosion resistant all aluminum with minimum brazed joints. This coil is 5/16 inch O.D. seamless aluminum glued to a continuous aluminum fin. Coils are lab tested to withstand 2,000 pounds of pressure per square inch. The outdoor coil provides low airflow resistance and efficient heat transfer. The coil is protected on all four sides by louvered panels.

Low Ambient Cooling

As manufactured, this unit has a cooling capability to 55°F. The addition of an evaporator defrost control permits operation to 30°F. The addition of a low ambient kit permits low ambient cooling to 0°F.

Accessories

Thermostats —

Heating/Cooling (manual and automatic changeover). Sub-base to match thermostat and locking thermostat cover.

Evaporator Defrost Control —

See Low Ambient Cooling.

Outdoor Thermostat —

Supplemental heat outdoor ambient lockout from 46 to -10°F.



Trane
www.trane.com

01/13

Trane has a policy of continuous product and product data improvement and it reserves the right to change design and specifications without notice.