

# TECHNICAL GUIDE

## PREDATOR®

### MID EFFICIENCY

### SINGLE PACKAGE AIR CONDITIONERS AND SINGLE PACKAGE GAS/ELECTRIC UNITS

DF 078, 090, 102 and 120

6-1/2, 7-1/2, 8-1/2 and 10 NOMINAL TONS

10.4 EER



## Heating and Air Conditioning

### DESCRIPTION

#### ASHRAE 90.1 COMPLIANT

YORK® DF Predator® units are convertible single packages with a common footprint cabinet and common roof curb for all 6-1/2 through 10 ton models. All units have two compressors with independent refrigeration circuits to provide 2 stages of cooling. The units were designed for light commercial applications and can be easily installed on a roof curb, slab, or frame.

All DF Predator® units are self-contained and assembled on rigid full perimeter base rails allowing for 3-way forklift access and overhead rigging. Every unit is completely charged, wired, piped, and tested at the factory to provide a quick and easy field installation.

All units are convertible between side and down airflow. Independent economizer designs are used on side and down discharge applications, as well as all tonnage sizes.

Predator® units are available in the following configurations: cooling only, cooling with electric heat, and cooling with gas heat. Electric heaters are available as factory-installed options and field-installed accessories.

*Tested in accordance with:*



## TABLE OF CONTENTS

<b>DESCRIPTION</b> .....	<b>1</b>	<u>Tbl. #</u>		<u>Pg. #</u>
<b>FEATURES</b> .....	<b>3</b>	9	ELECTRICAL DATA DF078 (6-1/2 TON) MID EFFICIENCY W/O PWRD CONVENIENCE OUTLET .....	20
<b>FACTORY INSTALLED OPTIONS</b> .....	<b>5</b>	10	ELECTRICAL DATA DF078 (6-1/2 TON) MID EFFICIENCY WITH PWRD CONVENIENCE OUTLET .....	20
<b>FIELD INSTALLED ACCESSORIES</b> .....	<b>6</b>	11	ELECTRICAL DATA DF090 (7-1/2 TON) MID EFFICIENCY W/O PWRD CONVENIENCE OUTLET .....	21
<b>NOMENCLATURE</b> .....	<b>10</b>	12	ELECTRICAL DATA DF090 (7-1/2 TON) MID EFFICIENCY WITH PWRD CONVENIENCE OUTLET .....	21
<b>GUIDE SPECIFICATIONS</b> .....	<b>44</b>	13	ELECTRICAL DATA DF102 (8-1/2 TON) MID EFFICIENCY W/O PWRD CONVENIENCE OUTLET .....	22

### LIST OF FIGURES

<u>Fig. #</u>			<u>Pg. #</u>	
1	PREDATOR® COMPONENT LOCATION (DF120 SHOWN) .....	3	14	ELECTRICAL DATA DF102 (8-1/2 TON) MID EFFICIENCY WITH PWRD CONVENIENCE OUTLET .....
2	POWER EXHAUST ACCESSORY DOWNFLOW APPLICATION .....	35	15	ELECTRICAL DATA DF120 (10 TON) MID EFFICIENCY W/O PWRD CONVENIENCE OUTLET .....
3	POWER EXHAUST ACCESSORY HORIZONTAL APPLICATION .....	35	16	ELECTRICAL DATA DF120 (10 TON) MID EFFICIENCY WITH PWRD CONVENIENCE OUTLET .....
4	UNIT 4 POINT LOAD .....	36	17	ELECTRIC HEAT MULTIPLIERS .....
5	UNIT CENTER OF GRAVITY .....	36	18	DF078 (6-1/2 TON) SIDE SHOT BLOWER PERFORMANCE .....
6	UNIT 6 POINT LOAD .....	36	19	DF090 (7-1/2 TON) SIDE SHOT BLOWER PERFORMANCE .....
7	UNIT DIMENSIONS .....	37	20	DF102 (8-1/2 TON) SIDE SHOT BLOWER PERFORMANCE .....
8	PREDATOR® ROOF CURB DIMENSIONS .....	38	21	DF120 (10 TON) SIDE SHOT BLOWER PERFORMANCE .....
9	SUNLINE™ TO PREDATOR® TRANSITION ROOF CURBS .....	38	22	DF078 (6-1/2 TON) DOWN SHOT BLOWER PERFORMANCE .....
10	BOTTOM DUCT OPENINGS .....	39	23	DF090 (7-1/2 TON) DOWN SHOT BLOWER PERFORMANCE .....
11	REAR DUCT DIMENSIONS .....	39	24	DF102 (8-1/2 TON) DOWN SHOT BLOWER PERFORMANCE .....
12	DOWNFLOW ECONOMIZER HOOD DETAIL .....	40	25	DF120 (10 TON) DOWN SHOT BLOWER PERFORMANCE .....
13	COOLING UNIT WITH GAS HEAT WIRING 230 VOLT DIAGRAM .....	41	26	ADDITIONAL STATIC RESISTANCE DF078, 120 .....
14	COOLING UNIT WITH/WITHOUT ELECTRIC HEAT WIRING DIAGRAM .....	42	27	ADDITIONAL STATIC RESISTANCE DF090, 102 .....
15	COOLING UNIT WITH GAS HEAT WIRING 460, 575 VOLT DIAGRAM .....	43	28	ELECTRIC HEAT MINIMUM SUPPLY AIR CFM .....

### LIST OF TABLES

<u>Tbl. #</u>			<u>Pg. #</u>	
1	ACCESSORIES .....	8	29	INDOOR BLOWER SPECIFICATIONS .....
2	DF PHYSICAL DATA .....	14	30	POWER EXHAUST SPECIFICATIONS .....
3	DF CAPACITY RATINGS .....	15	31	4 POINT LOAD WEIGHT .....
4	UNIT VOLTAGE LIMITATIONS .....	15	32	6 POINT LOAD WEIGHT .....
5	COOLING CAPACITY DF078 (6-1/2 TON) UNIT .....	16	33	UNIT WEIGHT .....
6	COOLING CAPACITY DF090 (7-1/2 TON) UNIT .....	17	34	UNIT HEIGHT .....
7	COOLING CAPACITY DF102 (8-1/2 TON) UNIT .....	18	35	UNIT CLEARANCES .....
8	COOLING CAPACITY DF120 (10 TON) UNIT .....	19		

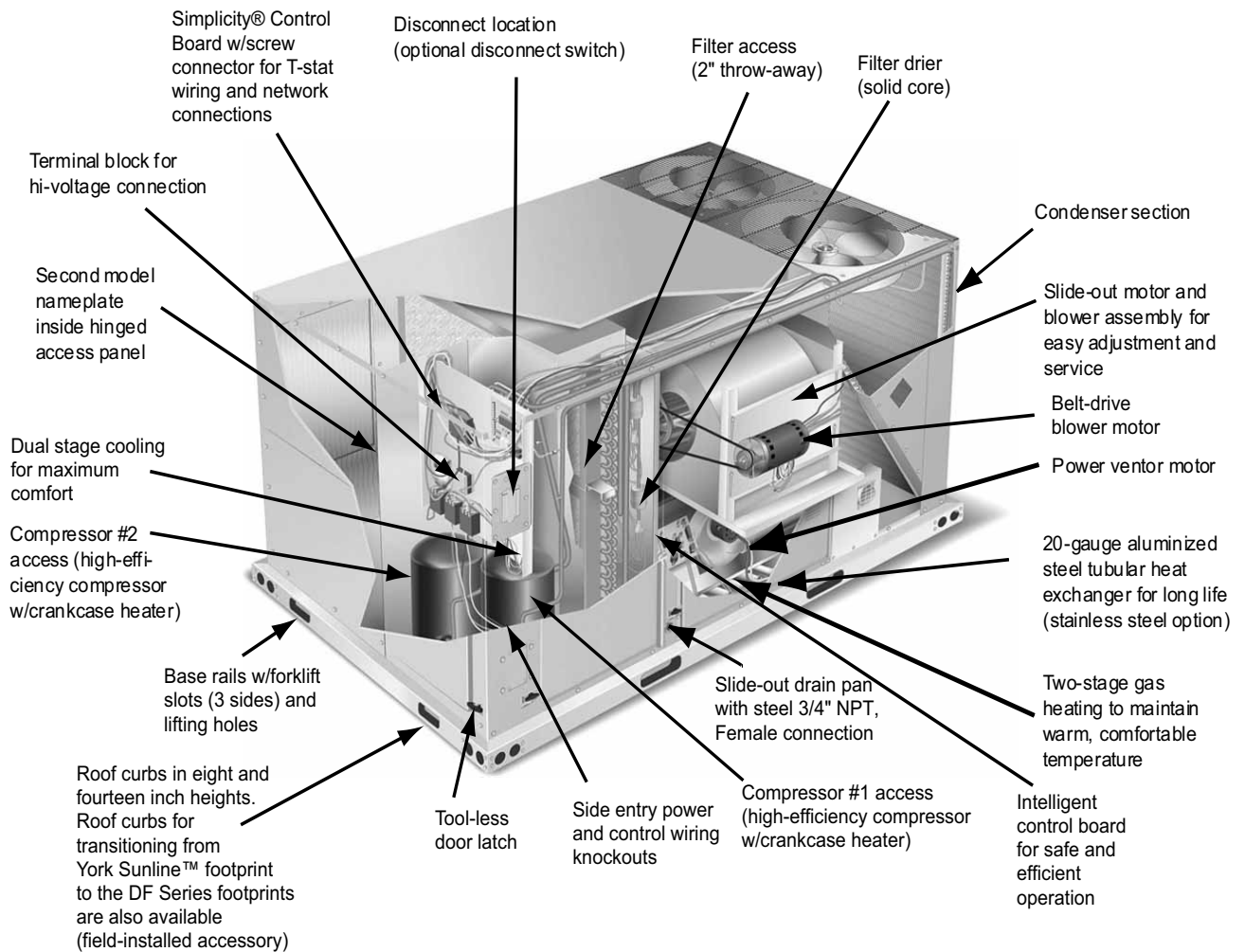

**FIGURE 1 - PREDATOR® COMPONENT LOCATION (DF120 SHOWN)**

## FEATURES

- **Mid Efficiency** - Mid efficiency units reach as high as 10.4 EER. Gas/electric units have electronic spark ignition and power vented combustion with steady state efficiencies of 80%. These efficiencies exceed all legislated minimum levels and provide low operating costs.
- **Service Friendly** - The Predator® incorporates a number of enhancements which improve serviceability.

The motor and blower slide out of the unit as a common assembly. This facilitates greater access to all the indoor airflow components, thus simplifying maintenance and adjustment.

Service time is reduced through the use of hinged, toolless panels. Such panels provide access to frequently inspected components and areas, including the control box, compressors, filters, indoor motor & blower,

and the heating section. The panels are screwed in place at the factory to prevent access by children or other unauthorized persons. It is recommended that the panels be secured with screws once service is complete.

Service windows have been placed in both condenser section walls. Rotation of the cover allows easy access to the condenser coils for cleaning or inspection.

Both the unit control board and ignition control board utilize flash codes to aid in diagnosis of unit malfunctions. Unique alarm codes quickly identify the source of the unit alarm.

All units use the same standard filter size. This standardization removes any confusion on which filter sizes are needed for replacement.

The non-corrosive drain pan slides out of the unit to permit easy cleaning. The drain pan is accessed by removing the drain pan cover plate on the rear of the unit. Once the plate is removed, the drain pan slides out through the rear of the unit.

All Predator® units have a second model nameplate located inside the control access door. This is to prevent deterioration of the nameplate through weathering.

- **Environmentally Aware** - For improved Indoor Air Quality, foil faced insulation is used exclusively throughout the units.
- **Balanced Heating** - The Predator® offers “Ultimate Heating Comfort” with a balance between 1<sup>st</sup> and 2<sup>nd</sup> stage gas heating. The first stage of a gas heat Predator® unit provides 60% of the heating capacity. Balanced heating allows the unit to better maintain desired temperatures.
- **Convertible Airflow Design** - The side duct openings are covered when they leave the factory. If a side supply/return is desired, the installer simply removes the two side duct covers from the outside of the unit and installs them over the down shot openings. No panel cutting is required. Convertible airflow design allows maximum field flexibility and minimum inventory.
- **System Protection** - Suction line freezestats are supplied on all units to protect against loss of charge and coil frosting when the economizer operates at low outdoor air temperatures while the compressors are running. Every unit has solid-core liquid line filter-driers and high and low-pressure switches. Internal compressor protection is standard on all compressors. Crankcase heaters are standard on reciprocating compressors. Scroll compressors do not require crankcase heaters. Phase Monitors are standard on units with scroll compressors. This accessory monitors the incoming power to the unit and protects the unit from phase loss and reversed phase rotation.
- **Advanced Controls** - Simplicity™ control boards have standardized a number of features previously available only as options or by utilizing additional controls.
  - **Low Ambient** - An integrated low-ambient control allows all units to operate in the cooling mode down to 0°F outdoor ambient without additional assistance. Optionally, the control board can be programmed to lockout the compressors when the outdoor air temperature is low or when free cooling is available.
  - **Anti-Short Cycle Protection** - To aid compressor life, an anti-short cycle delay is incorporated into the standard controls. Compressor reliability is further ensured by programmable minimum run times. For testing, the anti-short cycle delay can be temporarily overridden with the push of a button.

- **Fan Delays** - Fan on and fan off delays are fully programmable. Furthermore, the heating and cooling fan delay times are independent of one another. All units are programmed with default values based upon their configuration of cooling and heat.
- **Safety Monitoring** - The control board monitors the high and low-pressure switches, the freezestats, the gas valve, if applicable, and the temperature limit switch on gas and electric heat units. The unit control board will alarm on ignition failures, compressor lockouts and repeated limit switch trips.
- **Nuisance Trip Protection and Strikes** - To prevent nuisance trouble calls, the control board uses a “three times, you’re out” philosophy. The high and low-pressure switches and the freezestats must trip three times within two hours before the unit control board will lock out the associated compressor.
- **On Board Diagnostics** - Each alarm will energize a trouble light on the thermostat, if so equipped, and flash an alarm code on the control board LED. Each high and low-pressure switch alarm as well as each freezestat alarm has its own flash code. The control board saves the five most recent alarms in memory, and these alarms can be reviewed at any time. Alarms and programmed values are retained through the loss of power.
- **Reliable** - From the beginning - All units undergo computer automated testing before they leave the factory. Units are tested for refrigerant charge and pressure, unit amperage, and 100% functionality. For the long term - All Predator® units are painted with a long lasting, powder paint that stands up over the life of the unit. The paint used has been proven by a 1000 hour salt spray test.
- **Flexible Placement** - All models and configurations share the same cabinet/footprint and thus the same roof curb. You have the flexibility to set one curb and choose the correct tonnage size and heating option after the internal loads have been determined.

To further simplify planning and installation, Predator® cabinets are designed to fit your roof. With the optional roof curb, the unit ductwork is designed to fit around 24” on-center joists or between 48” on-center joists.

The drain pan can be rotated to drain to either the front or the rear of the unit. Additionally, the drain pan can be fitted to drain through the roof curb. As it is sometimes difficult to have a level installation, the drain pan features a generous slope to ensure proper drainage.

- **Full Perimeter Base Rails** - The permanently attached base rails provide a solid foundation for the entire unit and protect the unit during shipment. The rails offer fork-lift access from 3 sides, and rigging holes are available so that an overhead crane can be used to place the units on a roof.

- **Easy Installation** - Gas and electric utility knockouts are supplied in the unit underside as well as the side of the unit. A clearly identified location is provided to mount a field supplied electrical disconnect switch. Utility connections can be made quickly and with a minimum amount of field labor.

All units are shipped with 2" throw-away filters installed.

- **Wide Range of Indoor Airflows** - All indoor fan motors are belt-drive type providing maximum flexibility to handle most airflow requirements. For high static applications, factory installed alternate indoor fan motors are available. With the optional indoor fan motor, all units can supply nominal airflow at a minimum of 1.5" ESP.
- **Warranty** - All models include a 1-year limited warranty on the complete unit. Compressors and electric heater elements each carry a 5-year warranty. Aluminized steel and stainless steel tubular heat exchangers carry a 10-year warranty.

## FACTORY INSTALLED OPTIONS

YORK® offers several equipment options factory installed, for the Predator® line.

- **Downflow Economizer - (With barometric relief)** - The economizer is provided with a single enthalpy input. The economizer is 2% low leakage type, and is shipped installed and wired. The installer needs only to assemble and mount the outdoor air hood (Provided). The economizer has spring return, fully modulating damper actuators and is capable of introducing up to 100% outdoor air. As the outdoor air intake dampers open, the return air dampers close. The changeover from mechanical refrigeration to economizer operation is regulated by the standard single enthalpy input. There is an optional input dual dry bulb available. To meet regulated air standards, the economizer control accepts an optional CO<sub>2</sub> input for demand ventilation. With single enthalpy input, the economizer control monitors outdoor air. The dual enthalpy kit provides a second input used to monitor the return air. With a dual input kit installed, the economizer control compares the values of the two enthalpy or temperature inputs and positions the dampers to provide the maximum efficiency possible.
- **Horizontal Economizer - (Without barometric relief)** - All features of the downflow economizer exist except you must order the duct mount barometric relief separately. **You must order a 1EH0408 if you are installing a power exhaust. You can order a 1RD0411 Barometric Relief for horizontal flow economizers only.**
- **BAS Ready Economizer -(With barometric relief)** - The economizer is provided with a Belimo actuator that requires a 0-10V DC input from an external source (i.e., field installed building automation system controller). Power exhaust options are available. The economizer is 2% low leakage type with spring return and fully modulating dampers capable of introducing up to 100% outside air. Also include 2" pleated filters.
- **Slab Economizer for Energy Recovery Ventilators-(With barometric relief and Fresh Air Hood)** - The economizer is provided with a single enthalpy input. The economizer is 2% low leakage type, and is shipped installed and wired. The economizer has spring return, fully modulating damper actuators and is capable of introducing up to 100% outdoor air. As the outdoor air intake dampers open, the return air dampers close. The changeover from mechanical refrigeration to economizer operation is regulated by the standard single enthalpy input. There is an optional input dual dry bulb available. To meet regulated air standards, the economizer control accepts an optional CO<sub>2</sub> input for demand ventilation. With single enthalpy input, the economizer control monitors outdoor air. The dual enthalpy kit provides a second input used to monitor the return air. With a dual input kit installed, the economizer control compares the values of the two enthalpy or temperature inputs and positions the dampers to provide the maximum efficiency possible.
- **Power Exhaust (Downflow only)** - This accessory installs in the unit with a down flow economizer.
- **Motorized Outdoor Air Damper** - The motorized outdoor air damper includes a slide-in/plug-in damper assembly with an outdoor air hood and filters. The outdoor air dampers open to the preset position when the indoor fan motor is energized. The damper has a range of 0% to 100% outdoor air entry. Factory installed option or field installed accessory.
- **Alternate Indoor Blower Motor** - For applications with high static restrictions, units are offered with optional indoor motors that provide higher static output and/or higher airflow, depending upon the installer's needs.
- **Aluminized Steel Gas Heat Exchanger** - For applications in non-corrosive environments.
- **Stainless Steel Gas Heat Exchanger** - For applications in corrosive environments, this option provides a full stainless steel heat exchanger assembly.
- **Stainless Steel Drain Pan** - An optional rust-proof stainless steel drain pan is available to provide years of trouble-free operation in corrosive environments.
- **Electric Heaters** - The electric heaters range from 9kW to 54kW and are available in all the voltage options of the base units. All heaters are dual staged. All heaters are intended for single point power supply.
- **Disconnect Switch** - For gas heat units and cooling units with electric heat, a HACR breaker sized to the unit is provided. For cooling only units, a switch sized to the largest electric heat available for the particular unit is provided. Factory installed option only.
- **Convenience Outlet - (Non-Powered / Powered)** - This option locates a 120V single-phase GFCI outlet with cover, on the corner of the unit housing adjacent to the compressors. The "Non-powered" option requires the installer to provide the 120V single-phase power source and wiring. The "Powered" option is powered by a step-down transformer in the unit. Factory installed option only.

- **Smoke Detectors** - The smoke detectors stop operation of the unit by interrupting power to the control board if smoke is detected within the air compartment. Available for both the supply and/or return air.
- **Phase Monitors** - Designed to prevent unit damage. The phase monitor will shut the unit down in an out-of-phase condition. **(Standard on units with Scroll Compressors.)**
- **Coil Guard** - Customers can purchase a coil guard kit to protect the condenser coil from damage. Additionally, this kit stops animals and foreign objects from entering the space between the inner condenser coil and the main cabinet. This is not a hail guard kit.
- **Dirty Filter Switch** - This kit includes a differential pressure switch that energizes the fault light on the unit thermostat, indicating that there is an abnormally high pressure drop across the filters. Factory installed option or field installed accessory.
- **Technicoat Condenser Coils** - The condenser coils are coated with a phenolic coating for protection against corrosion due to harsh environments.
- **Technicoat Evaporator Coil** - The evaporator coils are coated with a phenolic coating for protection against corrosion due to harsh environments.
- **BAS - Building Automation System Controls Simplicity™ INTELLI-Comfort™ Control** - The York® Simplicity™ INTELLI-Comfort™ control is factory installed. It includes a supply air sensor, a return air sensor, and an outside air sensor. There are provisions for a field installed dirty filter indicator switch, an air-proving switch, an Outside Air Humidity sensor, a Return Air Humidity sensor, an Inside IAQ sensor, and an Outside Air IAQ sensor. Construction mode operation, 365-day real time clock with 7 day programming plus holiday scheduling is built-in. Two different modes of demand ventilation are achieved through the INTELLI-Comfort™ using CO<sub>2</sub> sensors. It uses an inside CO<sub>2</sub> sensor to perform Demand Ventilation. It can also use an Outside CO<sub>2</sub> sensor to perform Differential Demand Ventilation. It uses a Patented Comfort Ventilation algorithm to provide comfortable ventilation air temperature. The patented economizer-loading algorithm will protect the equipment when harsh operating conditions exist. Humidity in the occupied space or return duct can be monitored and controlled via humidity sensors and the on-board connection for hot gas re-heat system. It uses the INTELLI-Start™ algorithm to maximize energy savings by recovering the building from the Unoccupied Setpoints to the Occupied Setpoints just in time for the Occupied Time Period to begin. The Simplicity™ INTELLI-Comfort™ balances space temperature, ventilation air temperature, CO<sub>2</sub> and humidity for ultimate comfort.
- **Simplicity™ INTELLI-Comfort™ with ModLINC Control** - The York® Simplicity™ INTELLI-Comfort™ with ModLINC control is factory installed. It includes all

the features of the INTELLI-Comfort™ control with an additional control to translate communications from MODBUS to the BACnet MSTP protocol.

- **Novar® BAS Control** - The Novar® ETC-3 building automation system controller is factory installed. Includes supply air sensor, return air sensor, dirty filter indicator switch, and air proving switch.
- **Johnson Controls BAS Control** - The Johnson Control YK-UNT-1126 building automation system controller is factory installed. Includes supply air sensor, return air sensor, dirty filter indicator switch, and air proving switch.
- **CPC BAS Control** - The Computer Process Controls Model 810-3060 ARTC Advanced Rooftop building automation system controller is factory installed. Includes supply air sensor, return air sensor, dirty filter indicator switch and air proving switch.
- **Honeywell BAS Control** - The Honeywell W7750C building automation system controller is factory installed. Includes air supply sensor, return air sensor, dirty filter indicator switch, and air proving switch.

## FIELD INSTALLED ACCESSORIES

YORK® offers several equipment accessories for field installation, for the Predator® line.

- **Downflow Economizer - (With barometric relief)** - The economizer is provided with a single enthalpy input. The economizer is 2% low leakage type. The economizer has spring return, fully modulating damper actuators and is capable of introducing up to 100% outdoor air. As the outdoor air intake dampers open, the return air dampers close. The changeover from mechanical refrigeration to economizer operation is regulated by the standard single enthalpy input. There is an optional input dual dry bulb available. To meet regulated air standards, the economizer control accepts an optional CO<sub>2</sub> input for demand ventilation. With single enthalpy input, the economizer control monitors outdoor air. The dual enthalpy kit provides a second input used to monitor the return air. With a dual input kit installed, the economizer control compares the values of the two enthalpy or temperature inputs and positions the dampers to provide the maximum efficiency possible
- **Horizontal Economizer - (Without barometric relief)** - All features of the downflow economizer exist except you must order the duct mount barometric relief separately. **You must order a 1EH0408 if you are installing a power exhaust. You can order a 1RD0411 Barometric Relief for horizontal flow economizers only.**
- **Slab Economizer for Energy Recovery Ventilator - (Without barometric relief or Fresh Air Hood)** - The economizer is provided with a single enthalpy input. The economizer is 2% low leakage type. The economizer has spring return, fully modulating damper actuators and is capable of introducing up to 100% outdoor air. As the outdoor air intake dampers open, the return air dampers

close. The changeover from mechanical refrigeration to economizer operation is regulated by the standard single enthalpy input. There is an optional input dual dry bulb available. To meet regulated air standards, the economizer control accepts an optional CO<sub>2</sub> input for demand ventilation. With single enthalpy input, the economizer control monitors outdoor air. The dual enthalpy kit provides a second input used to monitor the return air. With a dual input kit installed, the economizer control compares the values of the two enthalpy or temperature inputs and positions the dampers to provide the maximum efficiency possible.

**You can order 1EH0409 Barometric Relief/FA Hood for field installations without an ERV.**

- **Dual Enthalpy Control, Accessory** - This kit contains the required components to convert a single enthalpy economizer to dual enthalpy.
- **Barometric Relief Damper** - Zero to 100% capacity barometric relief dampers for use with horizontal flow, or field installed slab economizers.
- **Power Exhaust** - This accessory installs in the unit with a down flow economizer. Power exhaust plugs into the connector in the unit bulkhead. **You must purchase 1EH0408 barometric relief when applying to a horizontal flow application.**
- **Manual Outdoor Air Damper** - Like the motorized outdoor air damper, each manual outdoor air damper includes a slide-in damper assembly with an outdoor air hood and filters. Customers have a choice of dampers with ranges of 0% to 100% or 0% to 35% outdoor air entry.
- **Motorized Outdoor Air Damper** - The motorized outdoor air damper includes a slide-in/plug-in damper assembly with an outdoor air hood and filters. The outdoor air dampers open to the preset position when the indoor fan motor is energized. The damper has a range of 0% to 100% outdoor air entry. Factory installed option or field installed accessory.
- **Smoke Detectors** - The smoke detectors stop operation of the unit by interrupting power to the control board if smoke is detected within the air compartment.
- **CO<sub>2</sub> Sensor** - Senses CO<sub>2</sub> levels and automatically overrides the economizer when levels rise above the preset limits.
- **Dirty Filter Switch** - This kit includes a differential pressure switch that energizes the fault light on the unit thermostat, indicating that there is an abnormally high pressure drop across the filters.
- **Coil Guard** - Field installed decorative wire coil guard.
- **Hail Guard** - This kit includes a sloped hood which installs over the outside condenser coil and prevents damage to the coil fins from hail strikes. Field installed accessory only.
- **Electric Heaters** - The electric heaters range from 9 kW to 54kW and are available in all the voltage options of the base units. All heaters are dual staged. Cooling units include an adapter panel for easy installation of the electric heaters. Necessary hardware and connectors are included with the heaters. All heaters are intended for single point power supply.
- **Metal Frame Filter Kit** - Metal frame with polyester filter medium.
- **Permanent Filters** - Permanent filters are available.
- **Roof Curbs** - The roof curbs have insulated decks and are shipped disassembled. The roof curbs are available in 8" and 14" heights. For applications with security concerns, burglar bars are available for the duct openings of the roof curbs.
- **Roof Curb Transition** - Single Piece Adapter (10" High) - Roof curbs for transitioning from Sunline™ units to Predator® units. Fits 7.5 to 12.5 Sunline™ roof curbs only.
- **Burglar Bars** - Mount in the supply and return openings to prevent entry into the duct work.
- **Thermostat** - The units are designed to operate with 24-volt electronic and electro-mechanical thermostats. All units (with or without an economizer) operate with two-stage heat/two-stage cool or two-stage cooling only thermostats, depending upon unit configuration.

**TABLE 1: ACCESSORIES**

Part Number	Description	Weight
1RC0470	Roof Curb, 8" Height	-
1RC0471	Roof Curb, 14" Height	-
1RC0472	Roof Curb, Transition (7.5 T through 12.5 T)	-
1BD0408	Burglar Bars, Downflow	-
2TP04520925	Electric Heat 9kW 230V	-
2TP04521825	Electric Heat 18kW 230V	-
2TP04522425	Electric Heat 24kW 230V	-
2TP04523625	Electric Heat 36kW 230V	-
2TP04525425	Electric Heat 54kW 230V	-
2TP04520946	Electric Heat 9kW 460V	-
2TP04521846	Electric Heat 18kW 460V	-
2TP04522446	Electric Heat 24kW 460V	-
2TP04523646	Electric Heat 36kW 460V	-
2TP04525446	Electric Heat 54kW 460V	-
2TP04520958	Electric Heat 9kW 575V	-
2TP04521858	Electric Heat 18kW 575V	-
2TP04522458	Electric Heat 24kW 575V	-
2TP04523658	Electric Heat 36kW 575V	-
2TP04525458	Electric Heat 54kW 575V	-
2TP04540925	Electric Heat 9kW 230V, 42" Tall Cabinet	-
2TP04541825	Electric Heat 18kW 230V, 42" Tall Cabinet	-
2TP04542425	Electric Heat 24kW 230V, 42" Tall Cabinet	-
2TP04543625	Electric Heat 36kW 230V, 42" Tall Cabinet	-
2TP04540946	Electric Heat 9kW 460V, 42" Tall Cabinet	-
2TP04541846	Electric Heat 18kW 460V, 42" Tall Cabinet	-
2TP04542446	Electric Heat 24kW 460V, 42" Tall Cabinet	-
2TP04543646	Electric Heat 36kW 460V, 42" Tall Cabinet	-
2TP04540958	Electric Heat 9kW 575V, 42" Tall Cabinet	-
2TP04541858	Electric Heat 18kW 575V, 42" Tall Cabinet	-
2TP04542458	Electric Heat 24kW 575V, 42" Tall Cabinet	-
2TP04543658	Electric Heat 36kW 575V, 42" Tall Cabinet	-
1FA0411	Manual Outside Air Damper 0-35%, Downflow (Incl. Hood, Damper & Filters, No Barometric Relief)	-
1FA0412	Manual Outside Air Damper 0-100%, Downflow (Incl. Hood, Damper & Filters, No Barometric Relief)	-
2MD04702724	Motorized Damper, Downflow (Incl. Hood, Damper & Filter, no Barometric Relief)	-
2MD04703324	Motorized Damper, Horizontal (Incl. Hood, Damper & Filter, no Barometric Relief)	-
2EE04705424	Economizer, Downflow (Incl. Barometric Relief & All Hoods)	124 lbs.
2EE04705524	Economizer, Horizontal (Incl. Dampers & Hoods, no Barometric Relief)	97 lbs.
2EE04705224	Economizer, Slab, Downflow (Incl. Dampers only no Hoods or Barometric Relief)	-
2EE04705624	"Downflow Economizer, Slab type for ERV (no Barometric Relief or FA hood)", 42" Tall Cabinet	-
2PE04703225	Power Exhaust, Downflow, 230V (For Units with Economizer only)	-
2PE04703246	Power Exhaust, Downflow, 460V (For Units with Economizer only)	-
2PE04703258	Power Exhaust, Downflow, 580V (For Units with Economizer only)	-
2EC04700924	Dual Enthalpy Control (Use with Single Enthalpy Economizer)	-
1EH0407	Hood Kit, Downflow Economizer (Included with all Downflow Economizers)	-
1RD0411	Barometric Relief Kit, Ductmount for Horizontal Application (Incl. Damper & Hood)	-
1EH0408	Barometric Relief Kit, Ductmount for Horizontal Application w/Power Exhaust (Incl. Damper & Hood)	25 lbs.
1EH0409	Barometric Relief / Hood Kit, for Field Installed Slab Econ. w/o ERV (Incl. Barometric Relief & FA Hood)	-
2AQ04700424	CO2 Detector Unit Mount	-
2AQ04700324	CO2 Detector Space Mount	-
2SD04700424	Smoke Detector, Supply or Return (Return Not Available with Horizontal Economizer)	-
2MK04700624	Low Limit / Compressor Lockout Kit	-
1CG0419	Coil Guard (Electric / Electric & HP models)	-
1CG0420	Coil Guard (Gas / Electric models)	-
1CG0427	Coil Guard (Electric / Electric & HP Models), 42" Tall Cabinet	-
1CG0428	Coil Guard (Gas / Electric Models), 42" Tall Cabinet	-

**TABLE 1: ACCESSORIES (CONTINUED)**

<b>Part Number</b>	<b>Description</b>	<b>Weight</b>
1HG0411	Hail Guard Kit	-
1HG0415	Hail Guard Kit, 42" Tall Cabinet	-
1GP0405	Gas Piping Kit	-
1NP0442	Propane Conversion Kit	-
1HA0442	High Altitude Kit for Natural Gas	-
1HA0443	High Altitude Kit for Propane	-
1FE0412	Flue Exhaust Extension Kit	-
2BC04700106	Gas Heat Kit, -60 deg F, 230V	-
2BC04700151	Gas Heat Kit, -60 deg F, 460V	-
2BC04700154	Gas Heat Kit, -60 deg F, 575V	-
1FL0402	Permanent Filter (Includes (4) Four Filters)	-
1FL0423	Permanent Filter (Includes (4) Four Filters), 42" Tall Cabinet	-
2DF0401	Dirty Filter Switch	-
1FF0410	Filter Frame Kit, Metal	-
1FF0411	Metal Filter Frame Kit, 42" Tall Cabinet	-

**NOMENCLATURE**

**6½ - 12½ Ton Predator Model Number Nomenclature**

**D F 090 N10 A 2 A AA 3**

**Product Category**  
D = Air Cond., Single Package

**Product Identifier**  
F = R-22 Mid Efficiency

**Nominal Cooling Capacity - MBH**  
078 = 6-½ Ton  
090 = 7-½ Ton  
102 = 8-½ Ton  
120 = 10 Ton

**Heat Type & Nominal Heat Capacity**  
C00 = Cooling Only. Suitable for field installed electric heat

**Gas Heat Options**  
N 10 = 100 MBH Output Aluminized Steel  
N 15 = 150 MBH Output Aluminized Steel  
N 20 = 200 MBH Output Aluminized Steel  
S 10 = 100 MBH Output Stainless Steel  
S 15 = 150 MBH Output Stainless Steel  
S 20 = 200 MBH Output Stainless Steel

**Electric Heat Options**  
E09 = 9 kW Electric Heat  
E18 = 18 kW Electric Heat  
E24 = 24 kW Electric Heat  
E36 = 36 kW Electric Heat  
E54 = 54 kW Electric Heat

**Product Generation**  
3 = Third Generation  
4 = Fourth Generation

**Voltage**  
2 = 208/230-3-60  
4 = 460-3-60  
5 = 575-3-60

**Installation Options**  
A = No Options Installed  
B = Option 1  
C = Option 2  
D = Options 1 & 2  
E = Option 3  
F = Option 4  
G = Options 1 & 3  
H = Options 1 & 4  
J = Options 1, 2 & 3  
K = Options 1, 2 & 4  
L = Options 1, 3 & 4  
M = Options 1, 2, 3 & 4  
N = Options 2 & 3  
P = Options 2 & 4  
Q = Options 2, 3 & 4  
R = Options 3 & 4  
S = Option 5  
T = Options 1 & 5  
U = Options 1, 3 & 5  
V = Options 1, 4 & 5  
W = Options 1, 3, 4 & 5  
X = Options 3 & 5  
Y = Options 4 & 5  
Z = Options 3, 4 & 5

**Options**  
1 = Disconnect  
2 = Non-Pwr'd Conv Outlet  
3 = Smoke Detector S. A.  
4 = Smoke Detector R. A.  
5 = Pwr'd Conv Outlet

**Additional Options**  
(See Next Page)

**Airflow**

A = Standard Motor  
B = Standard Motor/Economizer/Barometric Relief (Downflow only)  
C = Standard Motor/Economizer/Power Exhaust (Downflow only)  
D = Standard Motor/Motorized Damper (Downflow only)  
E = Standard Motor/Horizontal Economizer (No Barometric Relief)  
F = Standard Motor/Slab Economizer/Power Exhaust (Downflow only)  
G = Standard Motor/Slab Economizer/Barometric Relief (Downflow only)  
L = Standard Motor/BAS Ready Econ (NoBASController)/Barometric Relief w/2" Pleated Filters (Downflow only)  
M = Standard Motor/BAS Ready Econ (NoBASController)/Power Exhaust w/2" Pleated Filters (Downflow only)  
N = High Static Motor  
P = High Static Motor/Economizer/Barometric Relief (Downflow only)  
Q = High Static Motor/Economizer/Power Exhaust (Downflow only)  
R = High Static Motor/Motorized Damper (Downflow only)  
S = High Static Motor/Horizontal Economizer (No Barometric Relief)  
T = High Static Motor/Slab Economizer/Power Exhaust (Downflow only)  
U = High Static Motor/Slab Economizer/Barometric Relief (Downflow only)  
Y = High Static Motor/BAS Ready Econ (NoBASController)/Barometric Relief w/2" Pleated Filters (Downflow only)  
Z = High Static Motor/BAS Ready Econ (NoBASController)/Power Exhaust w/2" Pleated Filters (Downflow only)

**NOMENCLATURE ADDITIONAL OPTIONS**

Additional Options	
AA	None
AB	Phase Monitor
AC	Coil Guard
AD	Dirty Filter Switch
AE	Phase Monitor & Coil Guard
AF	Phase Monitor & Dirty Filter Switch
AG	Coil Guard & Dirty Filter Switch
AH	Phase Monitor, Coil Guard, & Dirty Filter Switch
AJ	SS Drain Pan
AK	SS Drain Pan & Phase Monitor
AL	SS Drain Pan & Coil Guard
AM	SS Drain Pan & Dirty Filter Switch
AN	SS Drain Pan, Phase Monitor, Coil Guard & Dirty Filter Switch
CA	CPC Controller with Dirty Filter Switch & Air Proving Switch
CB	CPC Controller, DFS, APS & Phase Monitor
CC	CPC Controller, DFS, APS & Coil Guard
CD	CPC Controller, DFS, APS, Phase Monitor, & Coil Guard
CE	CPC Controller, DFS, APS & Technicoat Cond. Coil
CF	CPC Controller, DFS, APS, Technicoat Cond. Coil, & Phase Monitor
CG	CPC Controller, DFS, APS, Technicoat Cond. Coil, & Coil Guard
CH	CPC Controller, DFS, APS, Technicoat Cond. Coil, Phase Monitor, & Coil Guard
CJ	CPC Controller, DFS, APS & Technicoat Evap. Coil
CK	CPC Controller, DFS, APS, Technicoat Evap. Coil, & Phase Monitor
CL	CPC Controller, DFS, APS, Technicoat Evap. Coil, & Coil Guard
CM	CPC Controller, DFS, APS, Technicoat Evap. Coil, Phase Monitor, & Coil Guard
CN	CPC Controller, DFS, APS & Technicoat Evap. & Cond Coils
CP	CPC Controller, DFS, APS, Technicoat Evap. & Cond Coils, & Phase Monitor
CQ	CPC Controller, DFS, APS, Technicoat Evap. & Cond Coils, & Coil Guard
CR	CPC Controller, DFS, APS, Technicoat Evap. & Cond Coils, Phase Monitor, & Coil Guard
CS	CPC Controller, DFS, APS, SS Drain Pan
CT	CPC Controller, DFS, APS, SS Drain Pan, Phase Monitor, & Coil Guard
CU	CPC Controller, DFS, APS, SS Drain Pan, & Technicoat Cond Coils
CV	CPC Controller, DFS, APS, SS Drain Pan, & Technicoat Evap Coil
CW	CPC Controller, DFS, APS, SS Drain Pan, & Technicoat Evap and Cond Coils
CX	CPC Controller, DFS, APS, SS Drain Pan, Phase Monitor, Coil Guard, & Technicoat Evap and Cond Coils
JA	Johnson UNT Controller with Dirty Filter Switch & Air Proving Switch
JB	Johnson UNT Controller, DFS, APS & Phase Monitor
JC	Johnson UNT Controller, DFS, APS & Coil Guard
JD	Johnson UNT Controller, DFS, APS, Phase Monitor, & Coil Guard
JE	Johnson UNT Controller, DFS, APS & Technicoat Cond. Coil
JF	Johnson UNT Controller, DFS, APS, Technicoat Cond. Coil, & Phase Monitor
JG	Johnson UNT Controller, DFS, APS, Technicoat Cond. Coil, & Coil Guard
JH	Johnson UNT Controller, DFS, APS, Technicoat Cond. Coil, Phase Monitor, & Coil Guard
JJ	Johnson UNT Controller, DFS, APS & Technicoat Evap. Coil
JK	Johnson UNT Controller, DFS, APS, Technicoat Evap. Coil, & Phase Monitor
JL	Johnson UNT Controller, DFS, APS, Technicoat Evap. Coil, & Coil Guard
JM	Johnson UNT Controller, DFS, APS, Technicoat Evap. Coil, Phase Monitor, & Coil Guard
JN	Johnson UNT Controller, DFS, APS & Technicoat Evap. & Cond Coils
JP	Johnson UNT Controller, DFS, APS, Technicoat Evap. & Cond Coils, & Phase Monitor
JQ	Johnson UNT Controller, DFS, APS, Technicoat Evap. & Cond Coils, & Coil Guard
JR	Johnson UNT Controller, DFS, APS, Technicoat Evap. & Cond Coils, Phase Monitor, & Coil Guard
JS	Johnson UNT Controller, DFS, APS, SS Drain Pan
JT	Johnson UNT Controller, DFS, APS, SS Drain Pan, Phase Monitor, & Coil Guard
JU	Johnson UNT Controller, DFS, APS, SS Drain Pan, & Technicoat Cond Coils
JV	Johnson UNT Controller, DFS, APS, SS Drain Pan, & Technicoat Evap Coil
JW	Johnson UNT Controller, DFS, APS, SS Drain Pan, & Technicoat Evap and Cond Coils
JX	Johnson UNT Controller, DFS, APS, SS Drain Pan, Phase Monitor, Coil Guard, & Technicoat Evap and Cond Coils

Additional Options	
HA	Honeywell Excel 10 Controller with Dirty Filter Switch & Air Proving Switch
HB	Honeywell Excel 10 Controller, DFS, APS & Phase Monitor
HC	Honeywell Excel 10 Controller, DFS, APS & Coil Guard
HD	Honeywell Excel 10 Controller, DFS, APS, Phase Monitor, & Coil Guard
HE	Honeywell Excel 10 Controller, DFS, APS & Technicoat Cond. Coil
HF	Honeywell Excel 10 Controller, DFS, APS, Technicoat Cond. Coil, & Phase Monitor
HG	Honeywell Excel 10 Controller, DFS, APS, Technicoat Cond. Coil, & Coil Guard
HH	Honeywell Excel 10 Controller, DFS, APS, Technicoat Cond. Coil, Phase Monitor, & Coil Guard
HJ	Honeywell Excel 10 Controller, DFS, APS & Technicoat Evap. Coil
HK	Honeywell Excel 10 Controller, DFS, APS, Technicoat Evap. Coil, & Phase Monitor
HL	Honeywell Excel 10 Controller, DFS, APS, Technicoat Evap. Coil, & Coil Guard
HM	Honeywell Excel 10 Controller, DFS, APS, Technicoat Evap. Coil, Phase Monitor, & Coil Guard
HN	Honeywell Excel 10 Controller, DFS, APS & Technicoat Evap. & Cond Coils
HP	Honeywell Excel 10 Controller, DFS, APS, Technicoat Evap. & Cond Coils, & Phase Monitor
HQ	Honeywell Excel 10 Controller, DFS, APS, Technicoat Evap. & Cond Coils, & Coil Guard
HR	Honeywell Excel 10 Controller, DFS, APS, Technicoat Evap. & Cond Coils, Phase Monitor, & Coil Guard
HS	Honeywell Excel 10 Controller, DFS, APS, SS Drain Pan
HT	Honeywell Excel 10 Controller, DFS, APS, SS Drain Pan, Phase Monitor, & Coil Guard
HU	Honeywell Excel 10 Controller, DFS, APS, SS Drain Pan, & Technicoat Cond Coils
HV	Honeywell Excel 10 Controller, DFS, APS, SS Drain Pan, & Technicoat Evap Coil
HW	Honeywell Excel 10 Controller, DFS, APS, SS Drain Pan, & Technicoat Evap and Cond Coils
HX	Honeywell Excel 10 Controller, DFS, APS, SS Drain Pan, Phase Monitor, Coil Guard, & Technicoat Evap and Cond Coils
WA	Intelli-Comfort w/ModLINC Controller
WB	Intelli-Comfort w/ModLINC Controller, & Phase Monitor
WC	Intelli-Comfort w/ModLINC Controller, & Coil Guard
WD	Intelli-Comfort w/ModLINC Controller, Phase Monitor, & Coil Guard
WE	Intelli-Comfort w/ModLINC Controller, & Technicoat Cond. Coil
WF	Intelli-Comfort w/ModLINC Controller, Technicoat Cond. Coil, & Phase Monitor
WG	Intelli-Comfort w/ModLINC Controller, Technicoat Cond. Coil, & Coil Guard
WH	Intelli-Comfort w/ModLINC Controller, Technicoat Cond. Coil, Phase Monitor, & Coil Guard
WJ	Intelli-Comfort w/ModLINC Controller, & Technicoat Evap. Coil
WK	Intelli-Comfort w/ModLINC Controller, Technicoat Evap. Coil, & Phase Monitor
WL	Intelli-Comfort w/ModLINC Controller, Technicoat Evap. Coil, & Coil Guard
WM	Intelli-Comfort w/ModLINC Controller, Technicoat Evap. Coil, Phase Monitor, & Coil Guard
WN	Intelli-Comfort w/ModLINC Controller, & Technicoat Evap. & Cond Coils
WP	Intelli-Comfort w/ModLINC Controller, Technicoat Evap. & Cond Coils, & Phase Monitor
WQ	Intelli-Comfort w/ModLINC Controller, Technicoat Evap. & Cond Coils, & Coil Guard
WR	Intelli-Comfort w/ModLINC Controller, Technicoat Evap. & Cond Coils, Phase Monitor, & Coil Guard
WS	Intelli-Comfort w/ModLINC Controller, SS Drain Pan
WT	Intelli-Comfort w/ModLINC Controller, SS Drain Pan, Phase Monitor, & Coil Guard
WU	Intelli-Comfort w/ModLINC Controller, SS Drain Pan, & Technicoat Cond Coils
WV	Intelli-Comfort w/ModLINC Controller, SS Drain Pan, & Technicoat Evap Coil
WW	Intelli-Comfort w/ModLINC Controller, SS Drain Pan, & Technicoat Evap and Cond Coils
WX	Intelli-Comfort w/ModLINC Controller, SS Drain Pan, Phase Monitor, Coil Guard, & Technicoat Evap and Cond Coils
NA	Novar ETC-3 Controller with Dirty Filter Switch & Air Proving Switch
NB	Novar ETC-3 Controller, DFS, APS & Phase Monitor
NC	Novar ETC-3 Controller, DFS, APS & Coil Guard
ND	Novar ETC-3 Controller, DFS, APS, Phase Monitor, & Coil Guard
NE	Novar ETC-3 Controller, DFS, APS & Technicoat Cond. Coil
NF	Novar ETC-3 Controller, DFS, APS, Technicoat Cond. Coil, & Phase Monitor
NG	Novar ETC-3 Controller, DFS, APS, Technicoat Cond. Coil, & Coil Guard
NH	Novar ETC-3 Controller, DFS, APS, Technicoat Cond. Coil, Phase Monitor, & Coil Guard
NJ	Novar ETC-3 Controller, DFS, APS & Technicoat Evap. Coil
NK	Novar ETC-3 Controller, DFS, APS, Technicoat Evap. Coil, & Phase Monitor
NL	Novar ETC-3 Controller, DFS, APS, Technicoat Evap. Coil, & Coil Guard
NM	Novar ETC-3 Controller, DFS, APS, Technicoat Evap. Coil, Phase Monitor, & Coil Guard
NN	Novar ETC-3 Controller, DFS, APS & Technicoat Evap. & Cond Coils
NP	Novar ETC-3 Controller, DFS, APS, Technicoat Evap. & Cond Coils, & Phase Monitor
NQ	Novar ETC-3 Controller, DFS, APS, Technicoat Evap. & Cond Coils, & Coil Guard

Additional Options	
NR	Novar ETC-3 Controller, DFS, APS, Technicoat Evap. & Cond Coils, Phase Monitor, & Coil Guard
NS	Novar ETC-3 Controller, DFS, APS, SS Drain Pan
NT	Novar ETC-3 Controller, DFS, APS, SS Drain Pan, Phase Monitor, & Coil Guard
NU	Novar ETC-3 Controller, DFS, APS, SS Drain Pan, & Technicoat Cond Coils
NV	Novar ETC-3 Controller, DFS, APS, SS Drain Pan, & Technicoat Evap Coil
NW	Novar ETC-3, DFS, APS, SS Drain Pan, & Technicoat Evap and Cond Coils
NX	Novar ETC-3 Controller, DFS, APS, SS Drain Pan, Phase Monitor, Coil Guard, & Technicoat Evap and Cond Coils
LA	Simplicity Intelli-Comfort Controller
LB	Simplicity Intelli-Comfort Controller, & Phase Monitor
LC	Simplicity Intelli-Comfort Controller, & Coil Guard
LD	Simplicity Intelli-Comfort Controller, Phase Monitor, & Coil Guard
LE	Simplicity Intelli-Comfort Controller, & Technicoat Cond. Coil
LF	Simplicity Intelli-Comfort Controller, Technicoat Cond. Coil, & Phase Monitor
LG	Simplicity Intelli-Comfort Controller, Technicoat Cond. Coil, & Coil Guard
LH	Simplicity Intelli-Comfort Controller, Technicoat Cond. Coil, Phase Monitor, & Coil Guard
LJ	Simplicity Intelli-Comfort Controller, & Technicoat Evap. Coil
LK	Simplicity Intelli-Comfort Controller, Technicoat Evap. Coil, & Phase Monitor
LL	Simplicity Intelli-Comfort Controller, Technicoat Evap. Coil, & Coil Guard
LM	Simplicity Intelli-Comfort Controller, Technicoat Evap. Coil, Phase Monitor, & Coil Guard
LN	Simplicity Intelli-Comfort Controller, & Technicoat Evap. & Cond Coils
LP	Simplicity Intelli-Comfort Controller, Technicoat Evap. & Cond Coils, & Phase Monitor
LQ	Simplicity Intelli-Comfort Controller, Technicoat Evap. & Cond Coils, & Coil Guard
LR	Simplicity Intelli-Comfort Controller, Technicoat Evap. & Cond Coils, Phase Monitor, & Coil Guard
LS	Simplicity Intelli-Comfort Controller, SS Drain Pan
LT	Simplicity Intelli-Comfort Controller, SS Drain Pan, Phase Monitor, & Coil Guard
LU	Simplicity Intelli-Comfort Controller, SS Drain Pan, & Technicoat Cond Coils
LV	Simplicity Intelli-Comfort Controller, SS Drain Pan, & Technicoat Evap Coil
LW	Simplicity Intelli-Comfort Controller, SS Drain Pan, & Technicoat Evap and Cond Coils
LX	Simplicity Intelli-Comfort Controller, SS Drain Pan, Phase Monitor, Coil Guard, & Technicoat Evap and Cond Coils
TA	Technicoat Condenser Coil
TB	Technicoat Condenser Coil & Phase Monitor
TC	Technicoat Condenser Coil & Coil Guard
TD	Technicoat Condenser Coil & Dirty Filter Switch
TE	Technicoat Condenser Coil, Phase Monitor, & Coil Guard
TF	Technicoat Condenser Coil, Phase Monitor, & Dirty Filter Switch
TG	Technicoat Condenser Coil, Coil Guard, & Dirty Filter Switch
TH	Technicoat Condenser Coil, Phase Monitor, Coil Guard, & Dirty Filter Switch
TJ	Technicoat Evaporator Coil
TK	Technicoat Evaporator Coil & Phase Monitor
TL	Technicoat Evaporator Coil & Coil Guard
TM	Technicoat Evaporator Coil & Dirty Filter Switch
TN	Technicoat Evaporator Coil, Phase Monitor, & Coil Guard
TP	Technicoat Evaporator Coil, Phase Monitor, & Dirty Filter Switch
TQ	Technicoat Evaporator Coil, Coil Guard, & Dirty Filter Switch
TR	Technicoat Evaporator Coil, Phase Monitor, Coil Guard, & Dirty Filter Switch
TS	Technicoat Evaporator & Condenser Coils
TT	Technicoat Evaporator & Condenser Coils & Phase Monitor
TU	Technicoat Evaporator & Condenser Coils & Coil Guard
TV	Technicoat Evaporator & Condenser Coils & Dirty Filter Switch
TW	Technicoat Evaporator & Condenser Coils, Phase Monitor, & Coil Guard
TX	Technicoat Evaporator & Condenser Coils, Phase Monitor, & Dirty Filter Switch
TY	Technicoat Evaporator & Condenser Coils, Coil Guard, & Dirty Filter Switch
TZ	Technicoat Evaporator & Condenser Coils, Phase Monitor, Coil Guard, & Dirty Filter Switch
T1	Technicoat Condenser & SS Drain Pan
T3	Technicoat Condenser Coil, SS Drain Pan, Phase Monitor, Coil Guard, & Dirty Filter Switch
T4	Technicoat Evaporator & SS Drain Pan
T6	Technicoat Evaporator Coil, SS Drain Pan, Phase Monitor, Coil Guard, & Dirty Filter Switch
T7	Technicoat Evaporator & Condenser Coils & SS Drain Pan
T9	Technicoat Evaporator & Condenser Coils, SS Drain Pan, Phase Monitor, Coil Guard, & Dirty Filter Switch

TABLE 2: DF PHYSICAL DATA

Component		Models			
		078	090	102	120
Evaporator Blower	Blower, Centrifugal (Dia. X Wd. in.)	15 x 15	12 x 12	12 x 12	15 x 15
	Motor, Standard (HP)	1.5	2	3	2
	Motor, Optional (HP)	2	3	3	3
Evaporator Coil	Rows	3	3	3	4
	Fins per Inch	15	15	15	15
	Height (in.)	32	32	32	40
	Face Area (ft. <sup>2</sup> )	10.67	10.67	10.67	13.2
Condenser Fan (2 per Unit)	Propeller Dia. (in.)	24	24	24	24
	Motor (HP, each)	1/3	1/3	3/4	3/4
	CFM, Nominal (each)	1700	1700	2200	2200
Condenser Coil (2 per unit)	Rows	1	1	Sys 1: 2 Row Sys 2: 1 Row	2
	Fins per Inch	20	20	20	20
	Height (in.)	44	36	36	44
	Face Area (ft. <sup>2</sup> )	14.5	12	12	14.5
Refrigerant Charge	System 1 (lb/oz)	6/12	5/4	9/12	11/1
	System 2 (lb/oz)	6/4	5/0	5/6	11/1
Compressors	Quantity	2	2	2	2
	Type	Recip	Recip	Recip	Recip
Air Filters	Size (Wd. x Ht. x Thickness in.)	25x20x2	25x16x2	25x16x2	25x20x2
	Number Per Unit	4	4	4	4

**TABLE 3: DF CAPACITY RATINGS**

Size (Tons)	Model	Cooling Capacity ARI Ratings*			CFM	Sound Rating (dB)†	Nominal Electric Heat Capacity‡ (kW)	Gas Heat Capacity				Gas Line Size (in. OD)
		MBH	EER	IPLV				Input (MBH)	Output (MBH)	Seasonal Efficiency (%)	Temp. Rise (°F)	
<b>078</b> (6-1/2)	Cooling Only						-	-	-	-	-	-
	Electric Heat	75	10.4	11.0	2600	84	9, 18, 24, 36	-	-	-	-	-
	Gas Heat						-	120	96	80	20-50	3/4
	Gas Heat						-	180	144	80	35-65	3/4
<b>090</b> (7-1/2)	Cooling Only						-	-	-	-	-	-
	Electric Heat	87	10.5	11.6	2516	84	18, 36	-	-	-	-	-
	Gas Heat						-	120	96	80	15-45	3/4
	Gas Heat						-	180	144	80	30-60	3/4
<b>102</b> (8-1/2)	Cooling Only						-	-	-	-	-	-
	Electric Heat	99	10.4	10.39	3055	84	9, 18, 24, 36	-	-	-	-	-
	Gas Heat						-	120	96	80	15-45	3/4
	Gas Heat						-	180	144	80	30-60	3/4
<b>120</b> (10)	Cooling Only						-	-	-	-	-	-
	Electric Heat	115	10.4	10.0	4000	90	18, 24, 36, 54	-	-	-	-	-
	Gas Heat						-	180	144	80	20-50	3/4
	Gas Heat						-	240	192	80	35-65	3/4

\* Rated at 95°F ambient 80°F dry bulb and 67°F wet bulb.

† Rated in accordance with ARI 270 standard.

‡ See Table 17.

**TABLE 4: UNIT VOLTAGE LIMITATIONS**

POWER RATING	MIN.	MAX.
<b>208/230-3-60</b>	187	252
<b>460-3-60</b>	432	504
<b>575-3-60</b>	540	630

\* The capacities are gross ratings. For net capacity, deduct indoor blower motor, MBH=3.415 x kW. Refer to the appropriate Blower Performance table for the kW of the supply air blower motor.

† Input power includes the condenser and compressor motors but not the indoor blower motor.

**TABLE 5: COOLING CAPACITY DF078 (6-1/2 TON) UNIT**

Return Air		Outdoor Ambient Temperature 85°F									Outdoor Ambient Temperature 95°F										
CFM	WB (°F)	Gross Cap.* (MBH)	Input† Power (kW)	Gross Sensible Capacity (MBH)* Return Air Dry Bulb (°F)								Gross Cap.* (MBH)	Input† Power (kW)	Gross Sensible Capacity (MBH)* Return Air Dry Bulb (°F)							
				86	83	80	77	74	71	68	86			83	80	77	74	71	68		
1950	72	84.1	5.92	50.0	44.4	38.8	33.3	27.7	-	-	80.2	6.37	48.3	42.7	37.2	31.6	26.1	-	-		
	67	77.4	5.78	62.7	57.1	51.6	46.0	40.5	34.9	29.3	71.8	6.20	60.1	54.6	49.0	43.4	37.9	32.3	26.8		
	62	70.9	5.65	70.9	67.9	62.4	56.8	51.3	45.7	40.1	64.4	6.05	64.4	63.9	58.4	52.8	47.3	41.7	36.1		
2275	57	68.2	5.63	68.2	68.2	62.7	57.2	51.6	46.0	40.5	59.5	5.99	59.5	59.5	53.9	48.4	42.8	37.3	31.7		
	72	87.3	5.96	55.3	48.7	42.1	35.5	29.0	-	-	83.4	6.42	53.9	47.3	40.7	34.1	27.6	-	-		
	67	80.3	5.82	69.0	62.5	55.9	49.3	42.8	36.2	29.6	74.7	6.26	66.8	60.2	53.7	47.1	40.5	33.9	27.4		
2600	62	73.5	5.69	73.5	72.0	67.6	61.1	54.5	47.9	41.3	66.9	6.10	66.9	66.7	63.9	61.9	50.8	44.2	37.7		
	57	70.7	5.67	70.7	70.7	68.0	61.4	54.8	48.3	41.7	61.8	6.05	61.8	61.8	59.1	52.5	45.9	39.4	32.8		
	72	90.4	6.01	60.5	53.0	45.4	37.8	30.2	-	-	86.6	6.48	59.4	51.8	44.3	36.7	29.1	-	-		
2925	67	83.2	5.87	75.4	67.8	60.2	52.7	45.1	37.5	29.9	77.6	6.31	73.5	65.9	58.3	50.7	43.2	35.6	28.0		
	62	76.1	5.74	76.1	76.1	72.9	65.3	57.7	50.1	42.5	69.5	6.15	69.5	69.5	69.5	61.9	54.3	46.8	39.2		
	57	73.2	5.72	73.2	73.2	73.2	65.7	58.1	50.5	42.9	64.2	6.10	64.2	64.2	64.2	56.6	49.1	41.5	33.9		
3250	72	91.6	6.05	65.0	56.3	47.7	39.1	30.4	-	-	87.4	6.54	64.1	55.5	46.8	38.2	29.6	-	-		
	67	84.4	5.91	80.5	72.0	63.3	54.7	46.1	37.4	28.8	78.3	6.37	76.2	70.3	61.7	53.1	44.4	35.8	27.2		
	62	77.2	5.78	77.2	77.2	75.6	66.9	58.3	49.6	41.0	70.1	6.21	70.1	70.1	70.1	61.5	52.9	44.2	35.6		
3250	57	74.3	5.76	74.3	74.3	74.3	65.6	57.0	48.4	39.7	64.8	6.15	64.8	64.8	64.8	56.2	47.5	38.9	30.3		
	72	92.9	6.09	69.4	59.7	50.0	40.4	30.7	-	-	88.2	6.59	68.8	59.1	49.4	39.7	30.0	-	-		
	67	85.5	5.95	85.5	76.1	66.4	56.7	47.1	37.4	27.7	79.0	6.42	79.0	74.8	65.1	55.4	45.7	36.0	26.3		
3250	62	78.2	5.81	78.2	78.2	78.2	68.6	58.9	49.2	39.5	70.8	6.26	70.8	70.8	70.8	61.1	51.4	41.7	32.0		
	57	75.3	5.80	75.3	75.3	75.3	65.6	55.9	46.2	36.5	65.4	6.21	65.4	65.4	65.4	55.7	46.0	36.3	26.7		
	<b>Outdoor Ambient Temperature 105°F</b>									<b>Outdoor Ambient Temperature 115°F</b>											
1950	72	74.0	6.84	46.1	40.5	35.0	29.4	23.9	-	-	67.8	7.31	43.9	38.3	32.8	27.2	21.6	-	-		
	67	64.9	6.62	57.4	51.8	46.3	40.7	35.1	29.6	24.0	58.0	7.03	54.6	49.1	43.5	38.0	32.4	26.8	21.3		
	62	57.5	6.45	57.5	57.3	51.8	46.2	40.7	35.1	29.5	50.6	6.86	50.6	50.6	45.2	39.6	34.0	28.5	22.9		
2275	57	56.1	6.52	56.1	56.1	50.5	45.0	39.4	33.8	28.3	52.8	7.05	52.8	52.6	47.1	41.5	36.0	30.4	24.8		
	72	76.5	6.90	51.4	44.8	38.2	31.7	25.1	-	-	69.6	7.37	48.9	42.3	35.8	29.2	22.6	-	-		
	67	67.1	6.67	62.3	57.1	50.6	44.0	37.4	30.9	24.3	59.5	7.09	57.9	54.1	47.5	40.9	34.4	27.8	21.2		
2600	62	59.5	6.51	59.5	59.4	56.6	50.0	43.5	36.9	30.3	52.0	6.92	52.0	52.0	49.3	42.7	36.1	29.6	23.0		
	57	58.0	6.58	58.0	58.0	55.2	48.7	42.1	35.5	28.9	54.2	7.11	54.2	54.2	51.4	44.8	38.2	31.7	25.1		
	72	79.0	6.96	56.7	49.1	41.5	33.9	26.3	-	-	71.5	7.43	53.9	46.3	38.8	31.2	23.6	-	-		
2925	67	69.3	6.73	67.3	62.5	54.9	47.3	39.7	32.2	24.6	61.1	7.15	61.1	59.1	51.5	43.9	36.3	28.7	21.1		
	62	61.5	6.56	61.5	61.5	61.5	53.9	46.3	38.7	31.1	53.4	6.98	53.4	53.4	53.4	45.8	38.3	30.7	23.1		
	57	59.9	6.63	59.9	59.9	59.9	52.4	44.8	37.2	29.6	55.7	7.16	55.7	55.7	55.7	48.1	40.5	32.9	25.4		
3250	72	79.7	7.02	61.3	52.7	44.1	35.4	26.8	-	-	72.0	7.50	58.6	49.9	41.3	32.7	24.0	-	-		
	67	69.9	6.79	68.9	65.4	58.3	49.7	41.0	32.4	23.8	61.6	7.22	61.6	60.5	54.9	46.2	37.6	29.0	20.3		
	62	62.0	6.63	62.0	62.0	62.0	53.3	44.7	36.1	27.4	53.8	7.04	53.8	53.8	53.8	45.2	36.5	27.9	19.3		
3250	57	60.4	6.69	60.4	60.4	60.4	51.8	43.2	34.5	25.9	56.1	7.23	56.1	56.1	56.1	47.4	38.8	30.2	21.5		
	72	80.4	7.09	66.0	56.3	46.6	36.9	27.3	-	-	72.5	7.58	63.3	53.6	43.9	34.2	24.5	-	-		
	67	70.5	6.85	70.5	68.4	61.7	52.0	42.3	32.6	22.9	62.0	7.29	62.0	62.0	58.3	48.6	38.9	29.2	19.5		
3250	62	62.5	6.69	62.5	62.5	62.5	52.8	43.1	33.4	23.7	54.2	7.11	54.2	54.2	54.2	44.5	34.8	25.1	15.4		
	57	60.9	6.76	60.9	60.9	60.9	51.3	41.6	31.9	22.2	56.5	7.31	56.5	56.5	56.5	46.8	37.1	27.4	17.7		
	<b>Outdoor Ambient Temperature 125°F</b>									<b>Outdoor Ambient Temperature 135°F</b>											
1950	72	61.6	7.8	41.7	36.1	30.6	25.0	19.4	-	-	-	-	-	-	-	-	-	-	-		
	67	51.0	7.4	51.0	46.3	40.8	35.2	29.7	24.1	18.5	-	-	-	-	-	-	-	-	-		
	62	43.8	7.3	43.8	43.8	38.6	33.0	27.4	21.9	16.3	-	-	-	-	-	-	-	-	-		
2275	57	49.4	7.6	49.4	49.2	43.6	38.1	32.5	27.0	21.4	-	-	-	-	-	-	-	-	-		
	72	62.7	7.8	46.4	39.8	33.3	26.7	20.1	-	-	-	-	-	-	-	-	-	-	-		
	67	52.0	7.5	52.0	51.0	44.4	37.8	31.3	24.7	18.1	-	-	-	-	-	-	-	-	-		
2600	62	44.6	7.3	44.6	44.6	42.0	35.4	28.8	22.3	15.7	-	-	-	-	-	-	-	-	-		
	57	50.4	7.6	50.4	50.3	47.5	41.0	34.4	27.8	21.2	-	-	-	-	-	-	-	-	-		
	72	63.9	7.9	51.2	43.6	36.0	28.4	20.8	-	-	-	-	-	-	-	-	-	-	-		
2925	67	52.9	7.6	52.9	52.9	48.1	40.5	32.9	25.3	17.7	-	-	-	-	-	-	-	-	-		
	62	45.4	7.4	45.4	45.4	45.4	37.8	30.2	22.6	15.1	-	-	-	-	-	-	-	-	-		
	57	51.4	7.7	51.4	51.4	51.4	43.8	36.2	28.7	21.1	-	-	-	-	-	-	-	-	-		
3250	72	64.3	8.0	55.8	47.2	38.6	29.9	21.3	-	-	-	-	-	-	-	-	-	-	-		
	67	53.2	7.6	53.2	53.2	51.5	42.8	34.2	25.6	16.9	-	-	-	-	-	-	-	-	-		
	62	45.6	7.5	45.6	45.6	45.6	37.0	28.4	19.7	11.1	-	-	-	-	-	-	-	-	-		
3250	57	51.7	7.8	51.7	51.7	51.7	43.1	34.4	25.8	17.2	-	-	-	-	-	-	-	-	-		
	72	64.7	8.1	60.5	50.8	41.1	31.4	21.7	-	-	-	-	-	-	-	-	-	-	-		
	67	53.5	7.7	53.5	53.5	53.5	45.2	35.5	25.8	16.1	-	-	-	-	-	-	-	-	-		
3250	62	45.9	7.5	45.9	45.9	45.9	36.2	26.5	16.8	7.1	-	-	-	-	-	-	-	-	-		
	57	52.0	7.9	52.0	52.0	52.0	42.3	32.6	22.9	13.2	-	-	-	-	-	-	-	-	-		

**TABLE 6: COOLING CAPACITY DF090 (7-1/2 TON) UNIT**

Air on Evaporator Coil		Temperature of Air on Condenser Coil																	
		75°F									85°F								
		CFM	WB (°F)	Total Cap.* (MBH)	Total† (kW)	Sensible Capacity (MBH)* Return Dry Bulb (°F)						Total Cap.* (MBH)	Total† (kW)	Sensible Capacity (MBH)* Return Dry Bulb (°F)					
86	83					80	77	74	71	68	86			83	80	77	74	71	68
2250	72	106.1	6.5	61.2	54.8	48.4	42.0	35.5	-	-	100.7	7.1	58.8	52.4	46.0	39.6	33.1	-	-
	67	99.1	6.3	75.8	69.4	63.0	56.5	50.1	43.7	37.3	92.8	6.9	73.5	67.0	60.6	54.2	47.8	41.4	35.0
	62	91.8	6.2	91.8	85.0	78.6	72.2	65.8	59.3	52.9	85.7	6.8	85.7	81.0	74.6	68.2	61.7	55.3	48.9
	57	89.3	6.2	89.3	89.0	82.6	76.2	69.8	63.4	57.0	84.7	6.8	84.7	83.7	77.3	70.9	64.5	58.1	51.7
2625	72	110.1	6.6	67.2	59.7	52.1	44.5	36.9	-	-	104.3	7.2	64.9	57.3	49.7	42.1	34.5	-	-
	67	102.8	6.4	82.9	75.3	67.8	60.2	52.6	45.0	37.4	96.2	7.0	80.7	73.1	65.5	57.9	50.4	42.8	35.2
	62	95.3	6.3	95.3	91.9	84.6	77.0	69.4	61.9	54.3	88.7	6.8	88.7	86.4	80.6	73.0	65.4	57.9	50.3
	57	92.7	6.3	92.7	92.6	89.0	81.4	73.8	66.2	58.6	87.7	6.8	87.7	87.2	83.6	76.0	68.4	60.8	53.3
3000	72	114.1	6.6	73.3	64.5	55.8	47.0	38.3	-	-	107.9	7.2	70.9	62.2	53.4	44.7	35.9	-	-
	67	106.6	6.4	90.1	81.3	72.6	63.8	55.1	46.3	37.6	99.5	7.1	87.9	79.2	70.4	61.7	52.9	44.2	35.4
	62	98.8	6.3	98.8	98.8	90.6	81.9	73.1	64.4	55.6	91.8	6.9	91.8	91.8	86.6	77.9	69.1	60.4	51.6
	57	96.1	6.3	96.1	96.1	95.3	86.6	77.8	69.1	60.3	90.7	6.9	90.7	90.7	89.8	81.1	72.3	63.6	54.9
3375	72	115.3	6.7	78.5	68.6	58.6	48.7	38.7	-	-	109.2	7.3	76.3	66.3	56.4	46.4	36.4	-	-
	67	107.7	6.5	98.1	86.2	76.3	66.3	56.3	46.4	36.4	100.7	7.1	94.2	84.3	74.3	64.4	54.4	44.4	34.5
	62	99.8	6.4	99.8	99.8	95.8	85.8	75.8	65.9	55.9	92.9	6.9	92.9	92.9	90.3	80.4	70.4	60.5	50.5
	57	97.1	6.4	97.1	97.1	96.7	86.8	76.8	66.8	56.9	91.9	6.9	91.9	91.9	91.4	81.5	71.5	61.5	51.6
3750	72	116.5	6.8	83.8	72.6	61.5	50.3	39.1	-	-	110.6	7.3	81.7	70.5	59.3	48.1	36.9	-	-
	67	108.8	6.6	106.0	91.1	79.9	68.8	57.6	46.4	35.2	101.9	7.1	100.5	89.4	78.2	67.0	55.8	44.7	33.5
	62	100.9	6.4	100.9	100.9	100.9	89.7	78.5	67.4	56.2	94.0	7.0	94.0	94.0	94.0	82.9	71.7	60.5	49.3
	57	98.1	6.4	98.1	98.1	98.1	86.9	75.8	64.6	53.4	93.0	7.0	93.0	93.0	93.0	81.8	70.6	59.5	48.3
		95°F									105°F								
2250	72	95.3	7.7	56.4	50.0	43.6	37.2	30.8	-	-	87.9	8.3	53.5	47.1	40.7	34.3	27.9	-	-
	67	86.6	7.5	71.1	64.7	58.3	51.9	45.5	39.1	32.6	79.1	8.1	67.9	61.5	55.1	48.6	42.2	35.8	29.4
	62	79.5	7.3	79.5	77.0	70.6	64.1	57.7	51.3	44.9	73.2	7.9	73.2	70.9	64.5	58.0	51.6	45.2	38.8
	57	80.1	7.3	80.1	78.5	72.0	65.6	59.2	52.8	46.4	74.2	7.9	74.2	72.5	66.1	59.6	53.2	46.8	40.4
2625	72	98.5	7.8	62.5	54.9	47.3	39.7	32.2	-	-	90.7	8.4	59.5	52.0	44.4	36.8	29.2	-	-
	67	89.5	7.6	78.5	70.9	63.3	55.7	48.1	40.6	33.0	81.6	8.1	74.3	67.6	60.1	52.5	44.9	37.3	29.7
	62	82.1	7.4	82.1	80.9	76.6	69.0	61.4	53.9	46.3	75.5	7.9	75.5	74.3	70.3	62.7	55.1	47.6	40.0
	57	82.7	7.4	82.7	81.9	78.2	70.6	63.0	55.5	47.9	76.5	8.0	76.5	75.7	72.1	64.5	56.9	49.3	41.7
3000	72	101.7	7.9	68.5	59.8	51.1	42.3	33.6	-	-	93.4	8.4	65.6	56.8	48.1	39.3	30.6	-	-
	67	92.4	7.7	85.8	77.0	68.3	59.5	50.8	42.0	33.3	84.1	8.2	80.8	73.8	65.1	56.3	47.6	38.8	30.1
	62	84.8	7.5	84.8	84.8	82.6	73.9	65.1	56.4	47.6	77.7	8.0	77.7	77.7	76.2	67.4	58.7	49.9	41.2
	57	85.4	7.4	85.4	85.4	84.4	75.6	66.9	58.1	49.4	78.9	8.0	78.9	78.9	78.1	69.3	60.6	51.8	43.1
3375	72	103.2	7.9	74.0	64.1	54.1	44.1	34.2	-	-	94.8	8.5	71.1	61.2	51.2	41.2	31.3	-	-
	67	93.7	7.7	90.4	82.3	72.4	62.4	52.4	42.5	32.5	85.4	8.3	83.7	78.4	69.3	59.3	49.4	39.4	29.4
	62	86.0	7.5	86.0	86.0	84.9	75.0	65.0	55.0	45.1	78.9	8.0	78.9	78.9	78.1	68.2	58.2	48.3	38.3
	57	86.6	7.5	86.6	86.6	86.1	76.2	66.2	56.2	46.3	80.1	8.1	80.1	80.1	79.7	69.7	59.7	49.8	39.8
3750	72	104.6	7.9	79.5	68.3	57.1	46.0	34.8	-	-	96.3	8.5	76.7	65.5	54.3	43.1	31.9	-	-
	67	95.1	7.7	95.1	87.6	76.4	65.3	54.1	42.9	31.7	86.7	8.3	86.7	83.0	73.5	62.3	51.1	40.0	28.8
	62	87.2	7.5	87.2	87.2	87.2	76.0	64.9	53.7	42.5	80.1	8.1	80.1	80.1	80.1	68.9	57.8	46.6	35.4
	57	87.9	7.5	87.9	87.9	87.9	76.7	65.5	54.3	43.2	81.3	8.1	81.3	81.3	81.3	70.1	58.9	47.7	36.6
		115°F									125°F								
2250	72	80.5	8.9	50.6	44.2	37.8	31.4	25.0	-	-	73.0	9.4	47.7	41.3	34.9	28.5	22.1	-	-
	67	71.7	8.6	64.6	58.2	51.8	45.4	39.0	32.6	26.2	64.2	9.2	61.4	55.0	48.6	42.1	35.7	29.3	22.9
	62	66.9	8.4	66.9	64.8	58.4	51.9	45.5	39.1	32.7	60.6	9.0	60.6	58.7	52.2	45.8	39.4	33.0	26.6
	57	68.3	8.5	68.3	66.5	60.1	53.7	47.2	40.8	34.4	62.5	9.1	62.5	60.5	54.1	47.7	41.3	34.8	28.4
2625	72	82.8	8.9	56.6	49.0	41.5	33.9	26.3	-	-	74.9	9.5	53.7	46.1	38.5	30.9	23.4	-	-
	67	73.7	8.7	70.2	64.4	56.8	49.3	41.7	34.1	26.5	65.8	9.3	65.8	61.2	53.6	46.0	38.4	30.9	23.3
	62	68.8	8.5	68.8	67.7	64.0	56.4	48.8	41.3	33.7	62.1	9.0	62.1	61.2	57.7	50.1	42.6	35.0	27.4
	57	70.3	8.6	70.3	69.4	65.9	58.3	50.7	43.2	35.6	64.1	9.2	64.1	63.1	59.7	52.2	44.6	37.0	29.4
3000	72	85.1	9.0	62.6	53.9	45.1	36.4	27.6	-	-	76.8	9.6	59.6	50.9	42.2	33.4	24.7	-	-
	67	75.8	8.8	75.8	70.6	61.9	53.1	44.4	35.6	26.9	67.5	9.4	67.5	67.4	58.7	49.9	41.2	32.4	23.7
	62	70.7	8.6	70.7	70.7	69.7	60.9	52.2	43.4	34.7	63.7	9.1	63.7	63.7	63.2	54.4	45.7	36.9	28.2
	57	72.3	8.7	72.3	72.3	71.7	63.0	54.2	45.5	36.7	65.8	9.3	65.8	65.8	65.4	56.7	47.9	39.2	30.4
3375	72	86.5	9.1	68.2	58.2	48.3	38.3	28.4	-	-	78.2	9.6	65.3	55.3	45.4	35.4	25.4	-	-
	67	77.1	8.8	77.1	74.4	66.2	56.2	46.3	36.3	26.3	68.7	9.4	68.7	68.7	63.1	53.2	43.2	33.2	23.3
	62	71.9	8.6	71.9	71.9	71.4	61.4	51.4	41.5	31.5	64.8	9.1	64.8	64.8	64.6	54.6	44.6	34.7	24.7
	57	73.5	8.7	73.5	73.5	73.2	63.2	53.3	43.3	33.3	66.9	9.3	66.9	66.9	66.7	56.8	46.8	36.8	26.9
3750	72	87.9	9.1	73.8	62.6	51.4	40.3	29.1	-	-	79.5	9.7	70.9	59.8	48.6	37.4	26.2	-	-
	67	78.3	8.8	78.3	78.3	70.5	59.4	48.2	37.0	25.8	69.9	9.4	69.9	69.9	67.6	56.4	45.2	34.1	22.9
	62	73.0	8.6	73.0	73.0	73.0	61.9	50.7	39.5	28.3	66.0	9.2	66.0	66.0	66.0	54.8	43.6	32.4	21.2
	57	74.7	8.7	74.7	74.7	74.7	63.5	52.3	41.1	30.0	68.1	9.3	68.1	68.1	68.1	56.9	45.7	34.5	23.4

\* The capacities are gross ratings. For net capacity, deduct indoor blower motor, MBH=3.415 x kW. Refer to the appropriate Blower Performance table for the kW of the supply air blower motor.

† These ratings include the condensate fan motors (total 1 kW) and the compressor motors but not the supply air blower motor.

**TABLE 7: COOLING CAPACITY DF102 (8-1/2 TON) UNIT**

Air on Evaporator Coil		Temperature of Air on Condenser Coil																	
		75°F									85°F								
		CFM	WB (°F)	Total Cap.* (MBH)	Total† Input (kW)	Sensible Capacity (MBH)* Return Dry Bulb (°F)						Total Cap.* (MBH)	Total† Input (kW)	Sensible Capacity (MBH)* Return Dry Bulb (°F)					
86	83					80	77	74	71	68	86			83	80	77	74	71	68
2550	72	120.3	7.1	67.8	60.5	53.3	46.0	38.7	-	-	114.1	7.8	64.6	57.3	50.1	42.8	35.5	-	-
	67	114.8	7.1	85.5	78.2	71.0	63.7	56.4	49.2	41.9	106.9	7.7	82.0	74.7	67.4	60.2	52.9	45.6	38.4
	62	105.5	7.0	105.5	97.4	90.1	82.8	75.6	68.3	61.0	98.6	7.6	98.6	91.9	84.7	77.4	70.1	62.9	55.6
	57	103.6	6.9	103.6	103.9	96.7	89.4	82.1	74.8	67.6	96.3	7.5	96.3	96.3	89.1	81.8	74.5	67.3	60.0
2975	72	122.9	7.1	73.8	65.2	56.6	48.0	39.4	-	-	116.6	7.8	70.8	62.2	53.6	45.0	36.5	-	-
	67	117.3	7.1	92.6	84.0	75.4	66.8	58.2	49.6	41.0	109.2	7.7	89.5	80.9	72.3	63.7	55.1	46.5	37.9
	62	107.7	7.0	107.7	103.7	95.7	87.1	78.5	69.9	61.4	100.7	7.6	100.7	97.3	90.7	82.1	73.5	64.9	56.4
	57	105.8	6.9	105.8	106.0	102.7	94.1	85.5	76.9	68.3	98.4	7.6	98.4	98.4	95.5	86.9	78.3	69.7	61.1
3400	72	125.5	7.2	79.7	69.8	59.9	50.0	40.1	-	-	119.0	7.9	77.1	67.1	57.2	47.3	37.4	-	-
	67	119.7	7.1	99.6	89.7	79.8	69.9	59.9	50.0	40.1	111.4	7.8	96.9	87.0	77.1	67.2	57.3	47.4	37.4
	62	110.0	7.0	110.0	110.0	101.3	91.4	81.5	71.6	61.7	102.8	7.6	102.8	102.8	96.8	86.9	77.0	67.0	57.1
	57	108.0	6.9	108.0	108.0	108.8	98.9	88.9	79.0	69.1	100.4	7.6	100.4	100.4	101.8	91.9	82.0	72.1	62.2
3825	72	129.6	7.2	84.8	73.5	62.2	50.9	39.7	-	-	121.9	7.9	82.5	71.2	59.9	48.7	37.4	-	-
	67	123.7	7.1	106.4	94.2	82.9	71.6	60.3	49.0	37.7	114.2	7.8	103.3	92.1	80.8	69.5	58.2	46.9	35.6
	62	113.6	7.0	113.6	113.6	107.4	96.2	84.9	73.6	62.3	105.3	7.7	105.3	105.3	101.4	90.1	78.8	67.5	56.2
	57	111.6	6.9	111.6	111.6	111.9	100.6	89.4	78.1	66.8	102.9	7.6	102.9	102.9	103.6	92.3	81.0	69.7	58.4
4250	72	133.8	7.2	89.9	77.3	64.6	51.9	39.2	-	-	124.9	7.9	88.0	75.3	62.7	50.0	37.3	-	-
	67	127.6	7.1	113.3	98.6	86.0	73.3	60.6	48.0	35.3	116.9	7.8	109.8	97.1	84.4	71.8	59.1	46.4	33.8
	62	117.3	7.0	117.3	117.3	113.6	100.9	88.2	75.6	62.9	107.8	7.7	107.8	107.8	106.0	93.3	80.6	68.0	55.3
	57	115.1	6.9	115.1	115.1	115.1	102.4	89.8	77.1	64.4	105.4	7.6	105.4	105.4	105.4	92.7	80.1	67.4	54.7
		95°F									105°F								
2550	72	108.0	8.5	61.4	54.1	46.8	39.6	32.3	-	-	99.8	9.2	58.0	50.8	43.5	36.2	29.0	-	-
	67	98.9	8.3	78.5	71.2	63.9	56.6	49.4	42.1	34.8	89.3	8.9	74.4	67.1	59.9	52.6	45.3	38.0	30.8
	62	91.6	8.2	91.6	86.5	79.2	71.9	64.7	57.4	50.1	82.3	8.8	82.3	79.7	73.3	66.0	58.8	51.5	44.2
	57	89.1	8.2	89.1	88.8	81.5	74.2	66.9	59.7	52.4	82.4	8.8	82.4	81.1	73.8	66.5	59.3	52.0	44.7
2975	72	110.2	8.5	67.9	59.3	50.7	42.1	33.5	-	-	101.7	9.2	64.5	55.9	47.3	38.7	30.1	-	-
	67	101.0	8.4	86.4	77.8	69.2	60.6	52.0	43.4	34.8	90.9	9.0	81.3	73.6	65.1	56.5	47.9	39.3	30.7
	62	93.6	8.2	93.6	91.0	85.7	77.1	68.5	60.0	51.4	83.9	8.8	83.9	82.6	79.7	71.1	62.5	53.9	45.3
	57	91.0	8.2	91.0	90.8	88.2	79.6	71.0	62.4	53.8	84.0	8.9	84.0	83.3	80.2	71.6	63.0	54.4	45.8
3400	72	112.5	8.6	74.4	64.5	54.6	44.6	34.7	-	-	103.5	9.3	70.9	61.0	51.1	41.2	31.2	-	-
	67	103.1	8.4	94.3	84.4	74.4	64.5	54.6	44.7	34.8	92.6	9.1	88.2	80.2	70.3	60.3	50.4	40.5	30.6
	62	95.5	8.3	95.5	95.5	92.3	82.3	72.4	62.5	52.6	85.4	8.9	85.4	85.4	86.0	76.1	66.2	56.3	46.4
	57	92.9	8.3	92.9	92.9	94.9	85.0	75.1	65.2	55.2	85.5	8.9	85.5	85.5	86.6	76.7	66.8	56.9	46.9
3825	72	114.2	8.6	80.2	68.9	57.6	46.4	35.1	-	-	105.7	9.3	77.0	65.7	54.4	43.1	31.8	-	-
	67	104.7	8.5	100.3	89.9	78.7	67.4	56.1	44.8	33.5	94.5	9.1	92.3	85.6	74.8	63.5	52.2	40.9	29.6
	62	96.9	8.3	96.9	96.9	95.3	84.0	72.7	61.5	50.2	87.2	9.0	87.2	87.2	87.5	76.2	64.9	53.6	42.3
	57	94.3	8.3	94.3	94.3	95.3	84.0	72.7	61.4	50.1	87.3	9.0	87.3	87.3	87.8	76.5	65.2	54.0	42.7
4250	72	115.9	8.7	86.1	73.4	60.7	48.1	35.4	-	-	107.8	9.4	83.0	70.3	57.7	45.0	32.3	-	-
	67	106.2	8.5	106.2	95.5	82.9	70.2	57.5	44.9	32.2	96.4	9.1	96.4	91.1	79.4	66.7	54.0	41.3	28.7
	62	98.4	8.4	98.4	98.4	98.4	85.7	73.1	60.4	47.7	88.9	9.0	88.9	88.9	88.9	76.2	63.6	50.9	38.2
	57	95.7	8.4	95.7	95.7	95.7	83.0	70.3	57.7	45.0	89.1	9.0	89.1	89.1	89.1	76.4	63.7	51.0	38.4
		115°F									125°F								
2550	72	91.7	9.9	54.7	47.4	40.2	32.9	25.6	-	-	83.6	10.5	51.4	44.1	36.8	29.6	22.3	-	-
	67	79.6	9.5	70.3	63.1	55.8	48.5	41.2	34.0	26.7	69.9	10.2	66.3	59.0	51.7	44.4	37.2	29.9	22.6
	62	73.0	9.4	73.0	73.0	67.4	60.1	52.9	45.6	38.3	63.7	10.0	63.7	63.7	61.5	54.2	46.9	39.7	32.4
	57	75.8	9.4	75.8	73.4	66.1	58.8	51.6	44.3	37.0	69.1	10.0	69.1	65.7	58.4	51.2	43.9	36.6	29.4
2975	72	93.2	9.9	61.1	52.5	43.9	35.3	26.7	-	-	84.6	10.6	57.6	49.1	40.5	31.9	23.3	-	-
	67	80.8	9.6	76.2	69.5	60.9	52.3	43.7	35.2	26.6	70.7	10.2	70.7	65.4	56.8	48.2	39.6	31.0	22.4
	62	74.2	9.5	74.2	74.2	73.6	65.0	56.4	47.8	39.2	64.5	10.1	64.5	64.5	64.5	59.0	50.4	41.8	33.2
	57	77.0	9.5	77.0	75.8	72.2	63.6	55.0	46.4	37.8	70.0	10.1	70.0	68.3	64.2	55.6	47.0	38.4	29.9
3400	72	94.6	10.0	67.4	57.5	47.6	37.7	27.8	-	-	85.6	10.7	63.9	54.0	44.1	34.2	24.3	-	-
	67	82.1	9.7	82.1	76.0	66.1	56.2	46.2	36.3	26.4	71.6	10.3	71.6	71.6	61.9	52.0	42.1	32.1	22.2
	62	75.3	9.5	75.3	75.3	79.8	69.9	60.0	50.1	40.2	65.2	10.2	65.2	65.2	65.2	63.7	53.8	43.9	34.0
	57	78.2	9.5	78.2	78.2	78.3	68.4	58.5	48.6	38.7	70.8	10.2	70.8	70.8	70.0	60.1	50.2	40.3	30.4
3825	72	97.2	10.0	73.7	62.4	51.1	39.8	28.5	-	-	88.7	10.7	70.4	59.1	47.8	36.5	25.2	-	-
	67	84.3	9.7	84.3	81.3	71.0	59.7	48.4	37.1	25.8	74.1	10.4	74.1	74.1	67.1	55.8	44.5	33.2	21.9
	62	77.4	9.6	77.4	77.4	79.6	68.3	57.0	45.7	34.5	67.6	10.2	67.6	67.6	67.6	60.5	49.2	37.9	26.6
	57	80.3	9.6	80.3	80.3	80.4	69.1	57.8	46.5	35.2	73.3	10.2	73.3	73.3	72.9	61.6	50.3	39.0	27.7
4250	72	99.8	10.1	79.9	67.3	54.6	41.9	29.3	-	-	91.7	10.8	76.9	64.2	51.5	38.9	26.2	-	-
	67	86.6	9.8	86.6	86.6	75.8	63.2	50.5	37.8	25.2	76.7	10.4	76.7	76.7	72.3	59.6	47.0	34.3	21.6
	62	79.4	9.7	79.4	79.4	79.4	66.8	54.1	41.4	28.7	69.9	10.3	69.9	69.9	69.9	57.3	44.6	31.9	19.3
	57	82.4	9.6	82.4	82.4	82.4	69.8	57.1	44.4	31.8	75.8	10.3	75.8	75.8	75.8	63.1	50.5	37.8	25.1

\* The capacities are gross ratings. For net capacity, deduct indoor blower motor, MBH=3.415 x kW. Refer to the appropriate Blower Performance table for the kW of the supply air blower motor.

† These ratings include the condensate fan motors (total 1 kW) and the compressor motors but not

**TABLE 8: COOLING CAPACITY DF120 (10 TON) UNIT**

Return Air		Outdoor Ambient Temperature 85°F									Outdoor Ambient Temperature 95°F										
CFM	WB (°F)	Gross Cap.* (MBH)	Input† Power (kW)	Gross Sensible Capacity (MBH) <sup>†</sup> Return Air Dry Bulb (°F)								Gross Cap.* (MBH)	Input† Power (kW)	Gross Sensible Capacity (MBH) <sup>†</sup> Return Air Dry Bulb (°F)							
				86	83	80	77	74	71	68	86			83	80	77	74	71	68		
3000	72	119.5	8.47	73.6	65.1	56.5	48.0	39.4	-	-	119.3	9.31	73.2	64.7	56.1	47.6	39.0	-	-		
	67	116.6	8.49	94.8	86.2	77.7	69.1	60.5	52.0	43.4	114.0	9.25	94.3	85.7	77.2	68.6	60.1	51.5	43.0		
	62	112.6	8.43	112.	106.	98.3	89.8	81.2	72.7	64.1	109.4	9.11	109.	105.	97.0	88.4	79.9	71.3	62.8		
	57	109.2	8.41	109.	109.	101.	93.0	84.4	75.9	67.3	109.1	9.16	108.	100.	91.6	83.0	74.4	65.9	57.3		
3500	72	122.4	8.52	80.0	69.9	59.8	49.7	39.6	-	-	122.0	9.34	80.0	69.9	59.8	49.6	39.5	-	-		
	67	119.4	8.54	102.	92.3	82.2	72.1	62.0	51.9	41.7	116.6	9.28	102.	92.3	82.2	72.1	61.9	51.8	41.7		
	62	115.3	8.47	115.	112.	104.	94.0	83.9	73.8	63.6	111.9	9.13	111.9	110.	103.	93.1	83.0	72.9	62.8		
	57	111.8	8.45	111.8	111.8	107.	97.3	87.2	77.1	67.0	111.6	9.19	111.4	107.	97.5	87.3	77.2	67.1	57.0		
4000	72	125.2	8.56	86.4	74.8	63.1	51.4	39.8	-	-	124.7	9.37	86.7	75.0	63.4	51.7	40.0	-	-		
	67	122.1	8.59	110.	98.4	86.7	75.0	63.4	51.7	40.1	119.2	9.31	110.	98.8	87.1	75.5	63.8	52.1	40.5		
	62	118.0	8.52	118.	118.	109.	98.2	86.5	74.8	63.2	114.4	9.16	114.	114.	109.	97.8	86.2	74.5	62.8		
	57	114.4	8.50	114.	114.	113.	101.	90.0	78.4	66.7	114.1	9.22	114.	114.	103.	91.7	80.0	68.4	56.7		
4500	72	125.5	8.56	91.5	78.2	64.9	51.6	38.3	-	-	125.8	9.41	92.6	79.3	66.0	52.8	39.5	-	-		
	67	122.4	8.59	115.	102.	89.2	75.9	62.6	49.3	36.1	120.2	9.35	115.	104.	90.8	77.5	64.2	50.9	37.7		
	62	118.3	8.52	118.	118.	113.	99.7	86.4	73.1	59.8	115.4	9.20	115.	115.	112.	99.7	86.4	73.1	59.8		
	57	114.7	8.50	114.	114.	114.	100.	87.6	74.3	61.0	115.1	9.25	115.	115.	107.	94.4	81.1	67.8	54.6		
5000	72	125.8	8.56	96.5	81.6	66.7	51.8	36.9	-	-	126.9	9.45	98.5	83.6	68.7	53.8	38.9	-	-		
	67	122.7	8.59	121.	106.	91.7	76.8	61.9	47.0	32.1	121.3	9.38	121.	109.	94.5	79.6	64.6	49.7	34.8		
	62	118.5	8.52	118.	118.	116.	101.	86.3	71.4	56.5	116.4	9.24	116.	116.	116.	101.	86.6	71.7	56.8		
	57	115.0	8.50	115.	115.	115.	100.	85.2	70.3	55.3	116.0	9.29	116.	116.	112.	97.1	82.2	67.3	52.4		
		Outdoor Ambient Temperature 105°F									Outdoor Ambient Temperature 115°F										
3000	72	113.3	10.02	71.2	62.6	54.1	45.5	37.0	-	-	107.2	10.74	69.1	60.5	52.0	43.4	34.9	-	-		
	67	106.2	9.85	91.5	82.9	74.4	65.8	57.3	48.7	40.2	98.5	10.44	88.7	80.1	71.6	63.0	54.5	45.9	37.4		
	62	103.6	9.74	103.	97.2	88.7	80.1	71.6	63.0	54.4	97.8	10.37	97.4	88.9	80.3	71.8	63.2	54.7	46.1		
	57	103.3	9.75	102.	93.9	85.3	76.8	68.2	59.7	51.1	97.6	10.34	96.2	87.7	79.1	70.6	62.0	53.5	44.9		
3500	72	117.0	10.10	78.6	68.5	58.4	48.2	38.1	-	-	111.9	10.85	77.2	67.1	57.0	46.8	36.7	-	-		
	67	109.7	9.92	100.	90.4	80.3	70.2	60.1	50.0	39.9	102.8	10.55	97.9	88.5	78.4	68.3	58.2	48.1	38.0		
	62	107.0	9.81	106.	103.	95.6	85.5	75.4	65.3	55.2	102.1	10.48	101.	97.7	88.0	77.9	67.8	57.7	47.6		
	57	106.7	9.82	106.	102.	92.1	82.0	71.9	61.8	51.6	101.9	10.45	101.	96.8	86.7	76.6	66.5	56.4	46.3		
4000	72	120.7	10.17	86.0	74.3	62.6	51.0	39.3	-	-	116.6	10.96	85.3	73.6	61.9	50.3	38.6	-	-		
	67	113.2	9.99	108.	97.9	86.2	74.5	62.9	51.2	39.5	107.1	10.66	107.	96.9	85.3	73.6	61.9	50.3	38.6		
	62	110.4	9.87	110.	110.	102.	90.9	79.3	67.6	55.9	106.4	10.59	106.	106.	95.7	84.0	72.4	60.7	49.0		
	57	110.1	9.89	110.	110.	98.8	87.2	75.5	63.8	52.2	106.2	10.56	106.	105.	94.3	82.6	71.0	59.3	47.6		
4500	72	121.9	10.22	92.5	79.2	65.9	52.6	39.3	-	-	117.9	11.03	92.3	79.1	65.8	52.5	39.2	-	-		
	67	114.3	10.04	112.	103.	90.7	77.4	64.1	50.8	37.5	108.3	10.73	108.	103.	90.6	77.3	64.0	50.7	37.4		
	62	111.5	9.93	111.5	111.5	107.	94.0	80.7	67.4	54.1	107.7	10.65	107.	107.	101.	88.4	75.1	61.8	48.5		
	57	111.2	9.94	111.2	111.2	103.	90.6	77.3	64.1	50.8	107.4	10.62	107.	107.	100.	86.9	73.6	60.3	47.0		
5000	72	123.1	10.27	99.0	84.1	69.2	54.3	39.3	-	-	119.3	11.10	99.4	84.5	69.6	54.7	39.8	-	-		
	67	115.4	10.09	115.	109.	95.2	80.3	65.3	50.4	35.5	109.6	10.79	109.	109.	95.9	81.0	66.1	51.1	36.2		
	62	112.6	9.98	112.	112.	112.	97.1	82.2	67.3	52.4	108.9	10.72	108.	108.	107.	92.7	77.8	62.9	48.0		
	57	112.3	9.99	112.	112.	109.	94.1	79.2	64.3	49.4	108.6	10.68	108.	108.	106.	91.1	76.2	61.3	46.4		
		Outdoor Ambient Temperature 125°F																			
3000	72	101.1	11.4	67.0	58.5	49.9	41.3	32.8	-	-											
	67	90.7	11.0	85.9	77.3	68.8	60.2	51.7	43.1	34.6											
	62	92.0	11.0	91.4	80.5	72.0	63.4	54.9	46.3	37.8											
	57	91.8	10.9	90.0	81.5	72.9	64.4	55.8	47.3	38.7											
3500	72	106.8	11.6	75.8	65.7	55.6	45.4	35.3	-	-											
	67	95.9	11.2	95.7	86.7	76.6	66.4	56.3	46.2	36.1											
	62	97.2	11.2	96.9	91.5	80.4	70.3	60.2	50.1	40.0											
	57	97.0	11.1	96.1	91.7	81.3	71.2	61.1	51.0	40.9											
4000	72	112.6	11.8	84.5	72.9	61.2	49.5	37.9	-	-											
	67	101.1	11.3	101.	96.0	84.3	72.7	61.0	49.4	37.7											
	62	102.5	11.3	102.	102.	88.8	77.1	65.5	53.8	42.1											
	57	102.2	11.2	102.	101.	89.7	78.1	66.4	54.8	43.1											
4500	72	114.0	11.8	92.2	78.9	65.6	52.4	39.1	-	-											
	67	102.4	11.4	102.	102.	90.5	77.2	63.9	50.6	37.3											
	62	103.8	11.4	103.	103.	96.0	82.7	69.4	56.1	42.9											
	57	103.5	11.3	103.	103.	96.4	83.1	69.8	56.5	43.2											
5000	72	115.4	11.9	99.9	85.0	70.1	55.2	40.3	-	-											
	67	103.7	11.5	103.	103.	96.6	81.7	66.8	51.8	36.9											
	62	105.1	11.5	105.	105.	103.	88.3	73.4	58.5	43.6											
	57	104.8	11.4	104.	104.	103.	88.1	73.2	58.2	43.3											

\* The capacities are gross ratings. For net capacity, deduct indoor blower motor, MBH=3.415 x kW. Refer to the appropriate Blower Performance table for the kW of the supply air blower motor.

† Input power includes the condenser and compressor motors but not the indoor blower motor.

**TABLE 9: ELECTRICAL DATA DF078 (6-1/2 TON) MID EFFICIENCY W/O PWRD CONVENIENCE OUTLET**

Voltage	Compressors		OD Fan Motors	Supply Blower Motor FLA		Pwr Exh Motor	Pwr Conv Outlet	Electric Heater Model No.	Actual KW	Heater Amps	Min. Circuit Ampacity (Amps)		MCA w/Power Exhaust (Amps)		Max Fuse* Size (Amps)		Max Fuse* Size w/Power Exhaust (Amps)	
	RLA ea.	LRA ea.	FLA ea.	1.5 HP	2 HP	FLA	FLA				1.5 HP	2 HP	1.5 HP	2 HP	1.5 HP	2 HP	1.5 HP	2 HP
208	10.6	78.0	1.5	6.2	8.2	5.5	0.0	None	--	--	33.1	35.1	38.6	40.6	40	45	45	50
								2TP04520925	6.8	18.9	33.1	35.1	38.6	40.7	40	45	45	50
								2TP04521825	13.5	37.5	54.6	57.1	61.5	64.0	60	60	70	70
								2TP04522425	18.0	50.0	70.2	72.7	77.1	79.6	80	80	80	80
								2TP04523625	25.5	70.8	96.2	98.7	103.1	105.6	100	100	110	110
230	10.6	78.0	1.5	6.2	8.2	5.5	0.0	None	--	--	33.1	35.1	38.6	40.6	40	45	45	50
								2TP04520925	9.0	21.7	34.8	37.3	41.7	44.2	40	45	45	50
								2TP04521825	18.0	43.3	61.9	64.4	68.8	71.3	70	70	70	80
								2TP04522425	24.0	57.7	79.9	82.4	86.8	89.3	80	90	90	90
								2TP04523625	34.0	81.8	110.0	112.5	116.9	119.4	110	125	125	125
460	5.2	40.0	0.8	3.1	4.1	2.2	0.0	None	--	--	16.4	17.4	18.6	19.6	20	20	20	20
								2TP04520946	9	11.3	17.4	18.7	20.2	21.4	20	20	25	25
								2TP04521846	18	22.6	30.9	32.2	33.7	34.9	35	35	35	35
								2TP04522446	24	30.1	40	41.2	42.7	44	40	45	45	45
								2TP04523646	34	42.7	55	56.2	57.7	59	60	60	60	60
575	4.1	32.0	0.6	2.4	3.6	1.8	0.0	None	--	--	12.8	14	14.6	15.8	15	15	15	20
								2TP04520958	9	9.0	13.8	15.3	16.1	17.6	15	20	20	20
								2TP04521858	18	18.1	24.7	26.2	26.9	28.4	25	30	30	30
								2TP04522458	24	24.1	31.9	33.4	34.1	35.6	35	35	35	40
								2TP04523658	34	34.1	43.9	45.4	46.1	47.6	45	50	50	50

\* Maximum HACR breaker of the same AMP size is applicable.

**TABLE 10: ELECTRICAL DATA DF078 (6-1/2 TON) MID EFFICIENCY WITH PWRD CONVENIENCE OUTLET**

Voltage	Compressors		OD Fan Motors	Supply Blower Motor FLA		Pwr Exh Motor	Pwr Conv Outlet	Electric Heater Model No.	Actual KW	Heater Amps	Min. Circuit Ampacity (Amps)		MCA w/Power Exhaust (Amps)		Max Fuse* Size (Amps)		Max Fuse* Size w/Power Exhaust (Amps)	
	RLA ea.	LRA ea.	FLA ea.	1.5 HP	2 HP	FLA	FLA				1.5 HP	2 HP	1.5 HP	2 HP	1.5 HP	2 HP	1.5 HP	2 HP
208	10.6	78.0	1.5	6.2	8.2	5.5	10.0	None	--	--	43.1	45.1	48.6	50.6	50	50	50	60
								2TP04520925	6.8	18.9	43.8	46.3	50.7	53.2	50	50	60	60
								2TP04521825	13.5	37.5	67.1	69.6	74.0	76.5	70	70	80	80
								2TP04522425	18.0	50.0	82.7	85.2	89.6	92.1	90	90	90	100
								2TP04523625	25.5	70.8	108.7	111.2	115.6	118.1	110	125	125	125
230	10.6	78.0	1.5	6.2	8.2	5.5	10.0	None	--	--	43.1	45.1	48.6	50.6	50	50	50	60
								2TP04520925	9.0	21.7	47.3	49.8	54.2	56.7	50	50	60	60
								2TP04521825	18.0	43.3	74.4	76.9	81.3	83.8	80	80	90	90
								2TP04522425	24.0	57.7	92.4	94.9	99.3	101.8	100	100	100	110
								2TP04523625	34.0	81.8	122.5	125.0	129.4	131.9	125	125	150	150
460	5.2	40.0	0.8	3.1	4.1	2.2	5.0	None	--	--	21.4	22.4	23.6	24.6	25	25	25	25
								2TP04520946	9	11.3	23.7	24.9	26.4	27.7	25	25	30	30
								2TP04521846	18	22.6	37.2	38.4	39.9	41.2	40	40	40	45
								2TP04522446	24	30.1	46.2	47.5	49	50.2	50	50	50	60
								2TP04523646	34	42.7	61.2	62.5	64	65.2	70	70	70	70
575	4.1	32.0	0.6	2.4	3.6	1.8	4.0	None	--	--	16.8	18	18.6	19.8	20	20	20	20
								2TP04520958	9	9.0	18.8	20.3	21.1	22.6	20	25	25	25
								2TP04521858	18	18.1	29.7	31.2	31.9	33.4	30	35	35	35
								2TP04522458	24	24.1	36.9	38.4	39.1	40.6	40	40	40	45
								2TP04523658	34	34.1	48.9	50.4	51.1	52.6	50	60	60	60

\* Maximum HACR breaker of the same AMP size is applicable.

**TABLE 11: ELECTRICAL DATA DF090 (7-1/2 TON) MID EFFICIENCY W/O PWRD CONVENIENCE OUTLET**

Voltage	Compressors		OD Fan Motors	Supply Blower Motor FLA		Pwr Exh Motor	Pwr Conv Outlet	Electric Heater Model No.	Actual KW	Heater Amps	Min. Circuit Ampacity (Amps)		MCA w/Power Exhaust (Amps)		Max Fuse* Size (Amps)		Max Fuse Size w/Power Exhaust (Amps)	
	RLA	LRA	FLA	2 HP	3 HP	FLA	FLA				2 HP	3 HP	2 HP	3 HP	2 HP	3 HP	2 HP	3 HP
	ea.	ea.	ea.															
208	12.8	84.0	1.5	8.2	10.9	5.5	0.0	None	--	--	40.0	42.7	45.5	48.2	50	50	50	60
								2TP04540925	6.8	18.9	40.0	42.7	45.5	48.2	50	50	50	60
								2TP04541825	13.5	37.5	57.1	60.5	64.0	67.3	60	70	70	70
								2TP04542425	18.0	50.0	72.7	76.1	79.6	83.0	80	80	80	90
								2TP04543625	25.5	70.8	98.7	102.1	105.6	109.0	100	110	110	110
230	12.8	84.0	1.5	8.2	10.9	5.5	0.0	None	--	--	40.0	42.7	45.5	48.2	50	50	50	60
								2TP04540925	9.0	21.7	40.0	42.7	45.5	48.2	50	50	50	60
								2TP04541825	18.0	43.3	64.4	67.8	71.3	74.6	70	70	80	80
								2TP04542425	24.0	57.7	82.4	85.8	89.3	92.7	90	90	90	100
								2TP04543625	34.0	81.8	112.5	115.9	119.4	122.7	125	125	125	125
460	5.8	42.0	0.8	4.1	5.3	2.2	0.0	None	--	--	18.8	20	21	22.2	20	25	25	25
								2TP04540946	9	11.3	18.8	20.2	21.4	22.9	20	25	25	25
								2TP04541846	18	22.6	32.2	33.7	34.9	36.4	35	35	35	40
								2TP04542446	24	30.1	41.2	42.7	44	45.5	45	45	45	50
								2TP04543646	34	42.7	56.2	57.7	59	60.5	60	60	60	70
575	5.1	34.0	0.6	3.6	4.1	1.8	0.0	None	--	--	16.3	16.8	18.1	18.6	20	20	20	20
								2TP04540958	9	9.0	16.3	16.8	18.1	18.6	20	20	20	20
								2TP04541858	18	18.1	26.2	26.8	28.4	29	30	30	30	30
								2TP04542458	24	24.1	33.4	34	35.6	36.2	35	35	40	40
								2TP04543658	34	34.1	45.4	46	47.6	48.3	50	50	50	50

**TABLE 12: ELECTRICAL DATA DF090 (7-1/2 TON) MID EFFICIENCY WITH PWRD CONVENIENCE OUTLET**

Voltage	Compressors		OD Fan Motors	Supply Blower Motor FLA		Pwr Exh Motor	Pwr Conv Outlet	Electric Heater Model No.	Actual KW	Heater Amps	Min. Circuit Ampacity (Amps)		MCA w/Power Exhaust (Amps)		Max Fuse* Size (Amps)		Max Fuse Size w/Power Exhaust (Amps)	
	RLA	LRA	FLA	2 HP	3 HP	FLA	FLA				2 HP	3 HP	2 HP	3 HP	2 HP	3 HP	2 HP	3 HP
	ea.	ea.	ea.															
208	12.8	84.0	1.5	8.2	10.9	5.5	10.0	None	--	--	51.1	53.8	56.6	59.3	60	60	60	70
								2TP04540925	6.8	18.9	51.1	53.8	56.6	59.3	60	60	60	70
								2TP04541825	13.5	37.5	69.6	73.0	76.5	79.8	70	80	80	80
								2TP04542425	18.0	50.0	85.2	88.6	92.1	95.5	90	90	100	100
								2TP04543625	25.5	70.8	111.2	114.6	118.1	121.5	125	125	125	125
230	12.8	84.0	1.5	8.2	10.9	5.5	10.0	None	--	--	51.1	53.8	56.6	59.3	60	60	60	70
								2TP04540925	9.0	21.7	51.1	53.8	56.7	60.1	60	60	60	70
								2TP04541825	18.0	43.3	76.9	80.3	83.8	87.1	80	90	90	90
								2TP04542425	24.0	57.7	94.9	98.3	101.8	105.2	100	100	110	110
								2TP04543625	34.0	81.8	125.0	128.4	131.9	135.2	125	150	150	150
460	5.8	42.0	0.8	4.1	5.3	2.2	5.0	None	--	--	26.7	27.9	28.9	30.1	30	30	35	35
								2TP04540946	9	11.3	26.7	27.9	28.9	30.1	30	30	35	35
								2TP04541846	18	22.6	38.4	39.9	41.2	42.7	40	40	45	45
								2TP04542446	24	30.1	47.5	49	50.2	51.7	50	50	60	60
								2TP04543646	34	42.7	62.5	64	65.2	66.7	70	70	70	70
575	5.1	34.0	0.6	3.6	4.1	1.8	4.0	None	--	--	21.7	22.2	23.5	24	25	25	25	25
								2TP04540958	9	9.0	21.7	22.2	23.5	24	25	25	25	25
								2TP04541858	18	18.1	31.2	31.8	33.4	34	35	35	35	35
								2TP04542458	24	24.1	38.4	39	40.6	41.2	40	40	45	45
								2TP04543658	34	34.1	50.4	51	52.6	53.3	60	60	60	60

**TABLE 13: ELECTRICAL DATA DF102 (8-1/2 TON) MID EFFICIENCY W/O PWRD CONVENIENCE OUTLET**

Voltage	Compressors		OD Fan Motors	Supply Blower Motor FLA		Pwr Exh Motor	Pwr Conv Outlet	Electric Heater Model No.	Actual KW	Heater Amps	Min. Circuit Ampacity (Amps)		MCA w/Power Exhaust (Amps)		Max Fuse* Size (Amps)		Max Fuse Size w/Power Exhaust (Amps)	
	RLA ea.	LRA ea.	FLA ea.	3 HP	3 HP	FLA	FLA				3 HP	3 HP	3 HP	3 HP	3 HP	3 HP	3 HP	3 HP
208	11.7	88.0	3.5	10.9	10.9	5.5	0.0	None	--	--	44.2	44.2	49.7	49.7	50	50	60	60
								2TP04540925	6.8	18.9	44.2	44.2	49.7	49.7	50	50	60	60
								2TP04541825	13.5	37.5	60.5	60.5	67.3	67.3	70	70	70	70
								2TP04542425	18	50.0	76.1	76.1	83.0	83.0	80	80	90	90
								2TP04543625	25.5	70.8	102.1	102.1	109.0	109.0	110	110	110	110
230	11.7	88.0	3.5	10.9	10.9	5.5	0.0	None	--	--	44.2	44.2	50.4	50.4	50	50	60	60
								2TP04540925	9	21.7	44.2	44.2	50.4	50.4	50	50	60	60
								2TP04541825	18	43.3	67.8	67.8	74.6	74.6	70	70	80	80
								2TP04542425	24	57.7	85.8	85.8	92.7	92.7	90	90	100	100
								2TP04543625	34	81.8	115.9	115.9	122.7	122.7	125	125	125	125
460	6.4	42.0	1.6	5.3	5.3	2.2	0.0	None	--	--	22.9	22.9	25.1	25.1	25	25	30	30
								2TP04540946	9	11.3	22.9	22.9	25.1	25.1	25	25	30	30
								2TP04541846	18	22.6	33.7	33.7	36.4	36.4	35	35	40	40
								2TP04542446	24	30.1	42.7	42.7	45.5	45.5	45	45	50	50
								2TP04543646	34	42.7	57.7	57.7	60.5	60.5	60	60	70	70
575	5.1	36.0	1.3	4.1	4.1	1.8	0.0	None	--	--	18.2	18.2	20	20	20	20	25	25
								2TP04540958	9	9.0	18.2	18.2	20	20	20	20	25	25
								2TP04541858	18	18.1	26.8	26.8	29	29	30	30	30	30
								2TP04542458	24	24.1	34	34	36.2	36.2	35	35	40	40
								2TP04543658	34	34.1	46	46	48.3	48.3	50	50	50	50

**TABLE 14: ELECTRICAL DATA DF102 (8-1/2 TON) MID EFFICIENCY WITH PWRD CONVENIENCE OUTLET**

Voltage	Compressors		OD Fan Motors	Supply Blower Motor FLA		Pwr Exh Motor	Pwr Conv Outlet	Electric Heater Model No.	Actual KW	Heater Amps	Min. Circuit Ampacity (Amps)		MCA w/Power Exhaust (Amps)		Max Fuse* Size (Amps)		Max Fuse Size w/Power Exhaust (Amps)	
	RLA ea.	LRA ea.	FLA ea.	3 HP	3 HP	FLA	FLA				3 HP	3 HP	3 HP	3 HP	3 HP	3 HP	3 HP	3 HP
208	11.7	88.0	3.5	10.9	10.9	5.5	10.0	None	--	--	54.2	54.2	59.7	59.7	60	60	70	70
								2TP04540925	6.8	18.9	54.2	54.2	59.7	59.7	60	60	70	70
								2TP04541825	13.5	37.5	73.0	73.0	79.8	79.8	80	80	80	80
								2TP04542425	18	50.0	88.6	88.6	95.5	95.5	90	90	100	100
								2TP04543625	25.5	70.8	114.6	114.6	121.5	121.5	125	125	125	125
230	11.7	88.0	3.5	10.9	10.9	5.5	10.0	None	--	--	54.2	54.2	59.7	59.7	60	60	70	70
								2TP04540925	9	21.7	54.2	54.2	59.7	59.7	60	60	70	70
								2TP04541825	18	43.3	80.3	80.3	87.1	87.1	90	90	90	90
								2TP04542425	24	57.7	98.3	98.3	105.2	105.2	100	100	110	110
								2TP04543625	34	81.8	128.4	128.4	135.2	135.2	150	150	150	150
460	6.4	42.0	1.6	5.3	5.3	2.2	10.0	None	--	--	27.9	27.9	30.1	30.1	30	30	35	35
								2TP04540946	9	11.3	27.9	27.9	30.1	30.1	30	30	35	35
								2TP04541846	18	22.6	39.9	39.9	42.7	42.7	40	40	45	45
								2TP04542446	24	30.1	49	49	51.7	51.7	50	50	60	60
								2TP04543646	34	42.7	64	64	66.7	66.7	70	70	70	70
575	5.1	36.0	1.3	4.1	4.1	1.8	10.0	None	--	--	22.2	22.2	24	24	25	25	25	25
								2TP04540958	9	9.0	22.2	22.2	24	24	25	25	25	25
								2TP04541858	18	18.1	31.8	31.8	34	34	35	35	35	35
								2TP04542458	24	24.1	39	39	41.2	41.2	40	40	45	45
								2TP04543658	34	34.1	51	51	53.3	53.3	60	60	60	60

**TABLE 15: ELECTRICAL DATA DF120 (10 TON) MID EFFICIENCY W/O PWRD CONVENIENCE OUTLET**

Voltage	Compressors		OD Fan Motors	Supply Blower Motor FLA		Pwr Exh Motor	Pwr Conv Outlet	Electric Heater Model No.	Actual KW	Heater Amps	Min. Circuit Ampacity (Amps)		MCA w/Power Exhaust (Amps)		Max Fuse* Size (Amps)		Max Fuse* Size w/Power Exhaust (Amps)				
				2 HP	3 HP	FLA	FLA				2 HP	3 HP	2 HP	3 HP	2 HP	3 HP	2 HP	3 HP			
	RLA ea.	LRA ea.	FLA ea.	2 HP	3 HP	FLA	FLA	2 HP	3 HP	2 HP	3 HP	2 HP	3 HP	2 HP	3 HP	2 HP	3 HP				
208	16.0	137.0	3.5	8.2	10.9	5.5	0.0	None	--	--	51.2	53.9	56.7	59.4	60	60	70	70			
								2TP04521825	13.5	37.5	57.1	60.5	64.0	67.3	60	70	70	70	90	90	
								2TP04522425	18.0	50.0	72.7	76.1	79.6	83.0	80	80	80	80	80	80	90
								2TP04523625	25.5	70.8	98.7	102.1	105.6	109.0	100	110	110	110	110	110	110
								2TP04525425	40.6	112.7	151.1	154.5	158.0	161.4	175	175	175	175	175	175	175
230	16.0	137.0	3.5	8.2	10.9	5.5	0.0	None	--	--	51.2	53.9	56.7	59.4	60	60	70	70			
								2TP04521825	18.0	43.3	64.4	67.8	71.3	74.6	70	70	80	80	80	80	
								2TP04522425	24.0	57.7	82.4	85.8	89.3	92.7	90	90	90	90	90	100	
								2TP04523625	34.0	81.8	112.5	115.9	119.4	122.7	125	125	125	125	125	125	
								2TP04525425	54.0	129.9	140.2	143.5	147.0	150.4	150	150	150	150	175	175	
460	8.3	69.0	1.6	4.1	5.3	2.2	0.0	None	--	--	26	27.2	28.2	29.4	30	35	35	35			
								2TP04521846	18	22.6	32.2	33.7	34.9	36.4	35	35	35	35	40		
								2TP04522446	24	30.1	41.2	42.7	44	45.5	45	45	45	45	50		
								2TP04523646	34	42.7	56.2	57.7	59	60.5	60	60	60	60	70		
								2TP04525446	54	67.8	70.1	71.6	72.8	74.3	80	80	80	80	80		
575	6.4	58.0	1.3	3.6	4.1	1.8	0.0	None	--	--	20.6	21.1	22.4	22.9	25	25	25	25			
								2TP04521858	18	18.1	26.2	26.8	28.4	29	30	30	30	30	30		
								2TP04522458	24	24.1	33.4	34	35.6	36.2	35	35	40	40	40		
								2TP04523658	34	34.1	45.4	46	47.6	48.3	50	50	50	50	50		
								2TP04525458	54	54.2	56.5	57.1	58.7	59.3	70	70	70	70	70		

\* Maximum HACR breaker of the same AMP size is applicable.

**TABLE 16: ELECTRICAL DATA DF120 (10 TON) MID EFFICIENCY WITH PWRD CONVENIENCE OUTLET**

Voltage	Compressors		OD Fan Motors	Supply Blower Motor FLA		Pwr Exh Motor	Pwr Conv Outlet	Electric Heater Model No.	Actual KW	Heater Amps	Min. Circuit Ampacity (Amps)		MCA w/Power Exhaust (Amps)		Max Fuse* Size (Amps)		Max Fuse* Size w/Power Exhaust (Amps)		
				2 HP	3 HP	FLA	FLA				2 HP	3 HP	2 HP	3 HP	2 HP	3 HP	2 HP	3 HP	
	RLA ea.	LRA ea.	FLA ea.	2 HP	3 HP	FLA	FLA	2 HP	3 HP	2 HP	3 HP	2 HP	3 HP	2 HP	3 HP	2 HP	3 HP		
208	16.0	137.0	3.5	8.2	10.9	5.5	10.0	None	--	--	61.2	63.9	66.7	69.4	70	70	80	80	
								2TP04521825	13.5	37.5	69.6	73.0	76.5	79.8	70	80	80	80	80
								2TP04522425	18.0	50.0	85.2	88.6	92.1	95.5	90	90	90	100	100
								2TP04523625	25.5	70.8	111.2	114.6	118.1	121.5	125	125	125	125	125
								2TP04525425	40.6	112.7	163.6	167.0	170.5	173.9	175	175	175	175	175
230	16.0	137.0	3.5	8.2	10.9	5.5	10.0	None	--	--	61.2	63.9	66.7	69.4	70	70	80	80	
								2TP04521825	18.0	43.3	76.9	80.3	83.8	87.1	80	90	90	90	90
								2TP04522425	24.0	57.7	94.9	98.3	101.8	105.2	100	100	110	110	110
								2TP04523625	34.0	81.8	125.0	128.4	131.9	135.2	125	150	150	150	150
								2TP04525425	54.0	129.9	152.7	156.0	159.5	162.9	175	175	175	175	175
460	8.3	69.0	1.6	4.1	5.3	2.2	5.0	None	--	--	31	32.2	33.2	34.4	35	40	40	40	
								2TP04521846	18	22.6	38.4	39.9	41.2	42.7	40	40	45	45	
								2TP04522446	24	30.1	47.5	49	50.2	51.7	50	50	60	60	
								2TP04523646	34	42.7	62.5	64	65.2	66.7	70	70	70	70	
								2TP04525446	54	67.8	76.3	77.8	79.1	80.6	90	90	90	90	
575	6.4	58.0	1.3	3.6	4.1	1.8	4.0	None	--	--	24.6	25.1	26.4	26.9	30	30	30	30	
								2TP04521858	18	18.1	31.2	31.8	33.4	34	35	35	35	35	
								2TP04522458	24	24.1	38.4	39	40.6	41.2	40	40	45	45	
								2TP04523658	34	34.1	50.4	51	52.6	53.3	60	60	60	60	
								2TP04525458	54	54.2	61.5	62.1	63.7	64.3	70	70	70	70	

\* Maximum HACR breaker of the same AMP size is applicable.

**TABLE 17: ELECTRIC HEAT MULTIPLIERS**

VOLTAGE		kW Cap. Multiplier
NOMINAL	RATING	
240	208	0.75
	230	0.92
480	460	0.92
600	575	0.92

**NOTE:** Electric heaters are rated at nominal voltage. Use this table to determine the electric heat capacity for heaters supplied at lower voltages.

**NOTES FOR TABLES 18 THROUGH TABLE 25:**

- Blower performance includes dry coil and 2" throwaway filters.
- Blower performance for gas heat includes the maximum number of heat tubes available for each tonnage.

ESP (External Static Pressure) given is that available for the supply and return air duct system. All internal resistances have been deducted from the total static pressure of the blower.

**TABLE 18: DF078 (6-1/2 TON) SIDE SHOT BLOWER PERFORMANCE**

CFM	External Static Pressure																			
	0.2		0.4		0.6		0.8		1.0		1.2		1.4		1.6		1.8			
	RPM	Watts	RPM	BHP	Watts	RPM	BHP	Watts	RPM	BHP	Watts	RPM	BHP	Watts	RPM	BHP	Watts	RPM	BHP	Watts
1900	----	----	687	0.69	641	0.81	758	0.95	884	893	1.18	1097	1.34	1252	1013	1.42	1324	1062	1.59	1484
2000	----	----	697	0.72	676	0.84	782	0.97	846	900	1.22	1137	1.39	1299	1019	1.48	1377	1067	1.65	1541
2100	----	----	707	0.76	712	0.87	810	0.97	854	907	1.26	1179	1.44	1346	1024	1.53	1430	1073	1.71	1599
2200	----	----	608	0.61	572	0.80	750	0.90	843	861	1.13	1055	1.50	1395	1030	1.59	1485	1078	1.78	1656
2300	----	----	623	0.66	614	0.85	790	0.94	880	869	1.19	1113	1.55	1444	1035	1.65	1541	1083	1.84	1713
2400	----	----	639	0.71	659	0.89	832	0.99	922	876	1.26	1172	1.60	1493	1041	1.71	1597	1088	1.90	1770
2500	602	0.59	550	0.76	705	0.94	877	1.04	968	884	1.32	1232	1.66	1544	1046	1.78	1655	1094	1.96	1827
2600	612	0.64	600	0.81	755	0.99	923	1.09	1019	891	1.39	1292	1.71	1595	1051	1.84	1713	1099	2.02	1884
2700	622	0.70	652	0.86	806	1.04	971	1.15	1074	899	1.45	1353	1.77	1647	1057	1.90	1773	1104	2.08	1941
2800	632	0.76	707	0.92	860	1.10	1022	1.22	1133	906	1.52	1414	1.82	1700	1062	1.97	1833	1109	2.14	1999
2900	642	0.82	764	0.98	917	1.15	1074	1.28	1197	914	1.58	1476	1.88	1753	1068	2.03	1894	-----	-----	-----
3000	652	0.88	823	1.05	976	1.21	1129	1.36	1266	921	1.65	1539	1.94	1807	1073	2.10	1956	-----	-----	-----
3100	662	0.95	885	1.11	1037	1.27	1185	1.44	1339	929	1.72	1602	2.00	1862	-----	-----	-----	-----	-----	-----
3200	672	1.02	949	1.18	1100	1.33	1244	1.52	1417	936	1.79	1666	2.06	1918	-----	-----	-----	-----	-----	-----
3300	682	1.09	1016	1.25	1166	1.40	1305	1.61	1499	944	1.86	1731	2.12	1974	-----	-----	-----	-----	-----	-----

High Horsepower Option Required

**TABLE 19: DF090 (7-1/2 TON) SIDE SHOT BLOWER PERFORMANCE**

CFM	External Static Pressure																													
	0.2		0.4		0.6		0.8		1.0		1.2		1.4		1.6		1.8		2											
	RPM	Watts	BHP	RPM	Watts	BHP	RPM	Watts	BHP	RPM	Watts	BHP	RPM	Watts	BHP	RPM	Watts	BHP	RPM	Watts	BHP									
2000	745	0.31	292	811	0.51	478	876	0.71	658	939	0.89	827	1001	1.05	980	1061	1.19	1113	1118	1.31	1221	1174	1.46	1361	1227	1.59	1486	1278	1.74	1622
2100	759	0.38	359	825	0.58	545	890	0.78	725	954	0.96	894	1015	1.12	1047	1075	1.27	1180	1133	1.38	1288	1188	1.54	1434	1241	1.67	1559	1292	1.82	1695
2200	774	0.46	429	841	0.66	615	906	0.85	795	969	1.03	964	1031	1.20	1117	1090	1.34	1251	1148	1.46	1359	1204	1.62	1508	1257	1.75	1633	1307	1.90	1769
2300	791	0.54	504	857	0.74	690	922	0.93	870	985	1.11	1039	1047	1.28	1192	1107	1.42	1325	1164	1.54	1433	1220	1.70	1584	1273	1.83	1709	1324	1.98	1845
2400	808	0.62	582	874	0.82	768	939	1.02	948	1002	1.20	1117	1064	1.36	1270	1124	1.51	1403	1182	1.62	1511	1237	1.78	1664	1290	1.92	1789	1341	2.06	1925
2500	826	0.71	664	892	0.91	850	957	1.11	1030	1020	1.29	1199	1082	1.45	1353	1142	1.59	1486	1200	1.71	1594	1255	1.87	1746	1308	2.01	1871	1359	2.15	2007
2600	845	0.81	750	911	1.00	936	976	1.20	1116	1039	1.38	1285	1101	1.54	1438	1161	1.69	1571	1219	1.80	1680	1274	1.97	1832	1327	2.10	1957	1378	2.25	2093
2700	865	0.90	840	931	1.10	1026	996	1.29	1206	1059	1.47	1375	1121	1.64	1528	1181	1.78	1661	1238	1.90	1769	1294	2.06	1922	1347	2.20	2046	1398	2.34	2183
2800	885	1.00	933	952	1.20	1119	1016	1.39	1299	1080	1.58	1468	1141	1.74	1621	1201	1.88	1755	1259	2.00	1863	1314	2.16	2015	1368	2.30	2140	1418	2.44	2276
2900	907	1.11	1030	973	1.30	1216	1038	1.50	1396	1101	1.68	1565	1163	1.84	1718	1222	1.99	1851	1280	2.10	1960	1336	2.27	2113	1389	2.40	2238	1439	2.55	2374
3000	929	1.21	1131	995	1.41	1317	1060	1.61	1497	1123	1.79	1666	1185	1.95	1819	1244	2.09	1952	1302	2.21	2060	1358	2.38	2214	1411	2.51	2339	1461	2.66	2475
3100	951	1.32	1235	1017	1.52	1421	1082	1.72	1601	1146	1.90	1769	1207	2.06	1923	1267	2.21	2056	1325	2.32	2164	1380	2.49	2320	1434	2.62	2445	1484	2.77	2581
3200	975	1.44	1342	1041	1.64	1528	1106	1.83	1708	1169	2.01	1877	1231	2.18	2030	1290	2.32	2163	1348	2.48	2311	1404	2.61	2431	1457	2.74	2555	1507	2.89	2691
3300	999	1.56	1453	1065	1.76	1639	1130	1.95	1819	1193	2.13	1987	1255	2.30	2141	1314	2.47	2304	1372	2.60	2425	1428	2.73	2545	1481	2.86	2670	1531	3.01	2806
3400	1023	1.68	1567	1089	1.88	1753	1154	2.07	1932	1218	2.25	2101	1279	2.46	2293	1339	2.60	2422	1397	2.73	2544	1452	2.86	2664	1505	2.99	2789	1556	3.14	2925
3500	1048	1.81	1684	1115	2.01	1870	1179	2.20	2049	1243	2.44	2273	1304	2.59	2416	1364	2.73	2546	1422	2.86	2667	1478	2.99	2787	1531	3.12	2912	1581	3.27	3048
3600	1074	1.94	1804	1140	2.13	1990	1205	2.33	2170	1269	2.58	2401	1330	2.73	2544	1390	2.87	2794	1448	3.00	2794	1503	3.13	2914	1556	3.26	3039	1639	3.40	3171
3700	1101	2.07	1927	1167	2.27	2113	1232	2.54	2369	1295	2.72	2532	1357	2.87	2676	1416	3.01	2805	1474	3.14	2926	1530	3.27	3046	1583	3.40	3171	1688	3.54	3303
3800	1127	2.20	2053	1194	2.48	2315	1258	2.69	2505	1322	2.86	2669	1383	3.02	2812	1443	3.15	2941	1501	3.29	3062	1556	3.40	3171	1639	3.54	3303	1743	3.68	3435
3900	1155	2.39	2232	1221	2.63	2455	1286	2.84	2645	1349	3.01	2809	1411	3.17	2952	1471	3.31	3081	1556	3.40	3171	1639	3.54	3303	1743	3.68	3435	1848	3.82	3567
4000	1183	2.55	2377	1249	2.79	2600	1314	2.99	2790	1377	3.17	2953	1439	3.32	3097	1501	3.46	3220	1601	3.59	3350	1601	3.72	3491	1714	3.85	3602	1903	3.96	3699
4100	1211	2.71	2525	1277	2.95	2748	1342	3.15	2939	1406	3.33	3102	1463	3.46	3246	1526	3.59	3350	1651	3.72	3491	1714	3.85	3602	1818	3.96	3699	2008	4.07	3796
4200	1240	2.87	2678	1306	3.11	2901	1371	3.32	3091	1431	3.46	3220	1488	3.59	3350	1556	3.72	3491	1714	3.85	3602	1818	3.96	3699	1923	4.07	3796	2103	4.18	3893
4300	1269	3.04	2835	1336	3.28	3058	1401	3.46	3246	1463	3.59	3350	1501	3.72	3491	1583	3.85	3602	1818	3.96	3699	1923	4.07	3796	2028	4.18	3893	2208	4.29	3989
4400	1299	3.21	2996	1366	3.44	3219	1431	3.62	3302	1493	3.72	3491	1526	3.85	3602	1601	3.96	3699	1923	4.07	3796	2028	4.18	3893	2153	4.29	3989	2303	4.40	4086
4500	1329	3.39	3161	1396	3.60	3388	1461	3.78	3467	1526	3.96	3699	1556	3.96	3699	1639	4.07	3796	2028	4.18	3893	2153	4.29	3989	2258	4.40	4086	2408	4.51	4182

High Horsepower Option Required

**TABLE 20: DF102 (8-1/2 TON) SIDE SHOT BLOWER PERFORMANCE**

CFM	External Static Pressure																					
	0.2		0.4		0.6		0.8		1.0		1.2		1.4		1.6		1.8					
	RPM	Watts	RPM	Watts	RPM	Watts	RPM	Watts	RPM	Watts	RPM	Watts	RPM	Watts	RPM	Watts	RPM	Watts				
2000	802	0.31	288	866	0.55	510	923	0.75	700	1025	1.08	1007	1137	1124	1.35	1259	1178	1.48	1378	1237	1.61	1503
2100	813	0.38	354	877	0.62	576	934	0.82	766	1036	1.15	1074	1203	1135	1.42	1325	1189	1.55	1445	1248	1.68	1569
2200	825	0.45	423	889	0.69	646	946	0.90	836	1048	1.23	1143	1273	1147	1.50	1394	1201	1.62	1514	1260	1.76	1638
2300	838	0.53	497	902	0.77	719	959	0.98	909	1061	1.30	1216	1346	1160	1.57	1467	1214	1.70	1587	1273	1.84	1712
2400	852	0.62	573	916	0.85	796	973	1.06	986	1075	1.39	1293	1423	1174	1.66	1544	1228	1.79	1664	1287	1.92	1788
2500	867	0.70	654	931	0.94	877	988	1.14	1067	1090	1.47	1374	1504	1189	1.74	1625	1243	1.87	1745	1302	2.01	1869
2600	882	0.79	739	946	1.03	962	1004	1.24	1152	1105	1.57	1459	1589	1204	1.83	1710	1258	1.96	1830	1318	2.10	1954
2700	899	0.89	829	963	1.13	1051	1020	1.33	1241	1122	1.66	1548	1678	1221	1.93	1800	1274	2.06	1919	1334	2.19	2044
2800	916	0.99	922	980	1.23	1145	1037	1.43	1335	1089	1.61	1498	1771	1238	2.03	1893	1292	2.16	2013	1328	2.28	2128
2900	934	1.09	1020	998	1.33	1243	1055	1.54	1433	1107	1.71	1596	1869	1255	2.14	1991	1309	2.26	2111	1346	2.40	2235
3000	952	1.20	1122	1016	1.44	1345	1073	1.65	1535	1125	1.82	1698	1972	1274	2.25	2093	1315	2.38	2215	1365	2.52	2347
3100	971	1.32	1229	1035	1.56	1451	1092	1.76	1641	1145	1.94	1805	2078	1293	2.36	2200	1335	2.50	2333	1385	2.64	2465
3200	991	1.44	1340	1055	1.68	1562	1112	1.88	1752	1164	2.06	1916	2189	1313	2.48	2311	1355	2.64	2456	1406	2.78	2588
3300	1012	1.56	1455	1076	1.80	1677	1133	2.00	1867	1185	2.18	2031	2304	1327	2.63	2450	1377	2.77	2584	1427	2.91	2716
3400	1033	1.69	1574	1097	1.93	1797	1154	2.13	1987	1206	2.31	2151	2424	1349	2.77	2583	1399	2.91	2717	1449	3.06	2849
3500	1054	1.82	1698	1118	2.06	1921	1176	2.26	2111	1228	2.44	2274	2578	1372	2.92	2720	1421	3.06	2854	1471	3.20	2986
3600	1077	1.96	1826	1141	2.20	2048	1198	2.40	2238	1250	2.58	2402	2720	1395	3.07	2861	1444	3.21	2996	1495	3.36	3128
3700	1100	2.10	1958	1164	2.34	2180	1221	2.54	2370	1273	2.72	2534	2865	1418	3.23	3007	1468	3.37	3141	*****	*****	*****
3800	1123	2.25	2094	1187	2.49	2316	1244	2.69	2506	1296	2.86	2670	3015	1442	3.39	3156	*****	*****	*****	*****	*****	*****
3900	1147	2.40	2234	1211	2.64	2457	1268	2.84	2647	1315	3.05	2843	3168	*****	*****	*****	*****	*****	*****	*****	*****	*****
4000	1171	2.55	2378	1236	2.79	2601	1293	2.99	2791	1340	3.22	2999	3171	*****	*****	*****	*****	*****	*****	*****	*****	*****
4100	1197	2.71	2526	1261	2.95	2749	1311	3.18	2966	1365	3.39	3160	*****	*****	*****	*****	*****	*****	*****	*****	*****	*****
4200	1222	2.87	2678	1286	3.11	2900	1337	3.36	3129	*****	*****	*****	*****	*****	*****	*****	*****	*****	*****	*****	*****	*****
4300	1248	3.04	2834	1306	3.30	3075	*****	*****	*****	*****	*****	*****	*****	*****	*****	*****	*****	*****	*****	*****	*****	*****
4400	1275	3.21	2993	*****	*****	*****	*****	*****	*****	*****	*****	*****	*****	*****	*****	*****	*****	*****	*****	*****	*****	*****
4500	1302	3.39	3156	*****	*****	*****	*****	*****	*****	*****	*****	*****	*****	*****	*****	*****	*****	*****	*****	*****	*****	*****

Optional Drive Required

**TABLE 21: DF120 (10 TON) SIDE SHOT BLOWER PERFORMANCE**

CFM	External Static Pressure																				
	0.2		0.4		0.6		0.8		1.0		1.2		1.4		1.6		1.8				
	RPM	Watts	RPM	BHP	Watts	RPM	BHP	Watts	RPM	BHP	Watts	RPM	BHP	Watts	RPM	BHP	Watts	RPM	BHP	Watts	
3000	741	1.20	1122	816	1.35	1256	865	1.46	1365	923	1.69	1571	971	1.91	1784	1035	2.04	1906	1092.2	2.26	2110
3100	705	1.13	1049	755	1.25	1167	828	1.41	1314	876	1.54	1431	933	1.75	1628	980	1.99	1851	1041	2.12	1976
3200	719	1.18	1100	769	1.31	1218	840	1.48	1376	887	1.61	1501	943	1.81	1691	988	2.06	1922	1048	2.20	2049
3300	733	1.24	1156	783	1.37	1274	851	1.55	1443	899	1.69	1575	952	1.89	1760	997	2.14	1997	1054	2.28	2125
3400	694	1.18	1102	747	1.30	1216	797	1.43	1336	863	1.62	1514	910	1.77	1653	962	1.97	1834	1006	2.23	2076
3500	707	1.25	1161	761	1.37	1281	811	1.51	1404	874	1.70	1589	922	1.86	1735	972	2.05	1915	1015	2.31	2158
3600	720	1.31	1224	775	1.45	1351	825	1.59	1477	886	1.79	1669	933	1.95	1821	982	2.15	2001	1023	2.41	2244
3700	733	1.38	1290	789	1.53	1426	839	1.67	1556	897	1.88	1753	944	2.05	1911	992	2.24	2092	1032	2.50	2334
3800	746	1.46	1361	803	1.61	1505	853	1.76	1641	909	1.98	1841	956	2.15	2005	1002	2.35	2190	1041	2.60	2427
3900	759	1.54	1435	817	1.70	1589	867	1.86	1731	920	2.07	1934	967	2.26	2103	1012	2.46	2293	1050	2.71	2624
4000	772	1.62	1513	831	1.80	1678	881	1.96	1827	932	2.18	2031	979	2.37	2205	1022	2.58	2402	1058	2.82	2625
4100	784	1.71	1595	845	1.90	1771	895	2.07	1928	943	2.29	2132	990	2.48	2311	1032	2.70	2516	1067	2.93	2729
4200	797	1.80	1680	859	2.01	1869	909	2.18	2035	955	2.40	2238	1001	2.60	2422	1042	2.83	2637	1076	3.04	2838
4300	810	1.90	1770	873	2.12	1972	923	2.30	2148	966	2.52	2348	1013	2.72	2536	1052	2.96	2763	1084	3.16	2949
4400	823	2.00	1863	887	2.23	2079	937	2.43	2266	978	2.64	2463	1024	2.85	2654	1062	3.11	2895	1093	3.29	3065
4500	836	2.10	1960	901	2.35	2191	951	2.56	2390	989	2.77	2581	1036	2.98	2776	1072	3.25	3032	1102	3.42	3184
4600	849	2.21	2061	915	2.48	2308	965	2.70	2519	1001	2.90	2705	1047	3.11	2902	1082	3.41	3175	1102	3.42	3184
4700	862	2.32	2166	929	2.61	2430	979	2.85	2654	1012	3.04	2832	1058	3.25	3032	1102	3.41	3175	1102	3.42	3184
4800	875	2.44	2274	943	2.74	2556	993	3.00	2795	1024	3.18	2964	1070	3.40	3166	1102	3.41	3175	1102	3.42	3184
4900	888	2.56	2387	957	2.88	2687	1007	3.15	2941	1036	3.33	3100	1102	3.41	3175	1102	3.41	3175	1102	3.41	3175
5000	901	2.69	2503	971	3.03	2823	1021	3.32	3093	1047	3.46	3184	1102	3.41	3175	1102	3.41	3175	1102	3.41	3175

High Horsepower Option Required

**TABLE 22: DF078 (6-1/2 TON) DOWN SHOT BLOWER PERFORMANCE**

CFM	External Static Pressure																	
	0.2		0.4		0.6		0.8		1.0		1.2		1.4		1.6			
	RPM	BHP	Watts	RPM	BHP	Watts	RPM	BHP	Watts	RPM	BHP	Watts	RPM	BHP	Watts	RPM	BHP	Watts
1900	733	0.75	698	804	0.9	825	881	1.03	963	931	1.21	1124	980	1.37	1279	1019	1.51	1409
2000	745	0.8	742	814	0.94	872	885	1.09	1017	939	1.27	1181	987	1.43	1336	1025	1.57	1465
2100	756	0.85	789	824	0.99	922	889	1.15	1073	946	1.33	1240	993	1.5	1395	1031	1.63	1521
2200	767	0.9	839	835	1.05	975	894	1.21	1131	954	1.4	1301	1000	1.56	1454	1036	1.69	1578
2300	778	0.96	891	845	1.1	1030	898	1.28	1191	962	1.46	1363	1006	1.63	1515	1042	1.76	1636
2400	789	1.01	946	855	1.17	1088	902	1.34	1253	969	1.53	1426	1013	1.69	1577	1047	1.82	1695
2500	801	1.08	1003	865	1.23	1148	906	1.41	1317	977	1.6	1491	1019	1.76	1641	1053	1.88	1755
2600	812	1.14	1063	875	1.3	1211	910	1.48	1384	985	1.67	1558	1026	1.83	1705	1059	1.95	1816
2700	823	1.21	1125	886	1.37	1276	914	1.56	1452	992	1.75	1627	1032	1.9	1771	1064	2.01	1878
2800	834	1.28	1190	896	1.44	1344	918	1.63	1523	1000	1.82	1697	1039	1.97	1838	1064	2.01	1878
2900	846	1.35	1257	906	1.52	1414	923	1.71	1596	1008	1.9	1769	1045	2.04	1906	1064	2.01	1878
3000	857	1.42	1327	916	1.59	1487	927	1.79	1671	1015	1.98	1842	1045	2.04	1906	1064	2.01	1878
3100	868	1.5	1400	926	1.68	1562	931	1.87	1748	1023	2.06	1917	1045	2.04	1906	1064	2.01	1878
3200	879	1.58	1475	937	1.76	1640	935	1.96	1827	1030	2.1	1988	1045	2.04	1906	1064	2.01	1878
3300	890	1.67	1552	947	1.85	1721	939	2.05	1908	1030	2.1	1988	1045	2.04	1906	1064	2.01	1878

High Horsepower Option Required

Motor Efficiency 0.8

Std HP Motor 1.5

**TABLE 23: DF090 (7-1/2 TON) DOWN SHOT BLOWER PERFORMANCE**

CFM	External Static Pressure																											
	0.2		0.4		0.6		0.8		1.0		1.2		1.4		1.6		1.8											
	RPM	BHP	Watts	RPM	BHP	Watts	RPM	BHP	Watts	RPM	BHP	Watts	RPM	BHP	Watts	RPM	BHP	Watts										
2000	814	0.52	488	888	0.71	665	960	0.89	834	1030	1.06	984	1103	1.18	1104	1179	1.27	1185	1253	1.51	1411	1411	1335	1.69	1577	1429	1.90	1773
2100	831	0.60	558	905	0.79	735	977	0.97	904	1047	1.13	1054	1120	1.26	1174	1196	1.35	1255	1266	1.60	1492	1349	1.78	1658	1443	1.99	1854	
2200	849	0.68	633	924	0.87	810	995	1.05	979	1066	1.21	1129	1138	1.34	1249	1214	1.43	1330	1282	1.69	1574	1364	1.87	1741	1458	2.08	1936	
2300	869	0.77	713	943	0.95	890	1015	1.14	1059	1086	1.30	1208	1158	1.43	1329	1234	1.51	1410	1299	1.78	1658	1381	1.96	1824	1475	2.17	2020	
2400	890	0.86	798	964	1.05	975	1036	1.23	1143	1106	1.39	1293	1179	1.52	1414	1255	1.60	1495	1317	1.87	1745	1400	2.05	1911	1493	2.26	2107	
2500	911	0.95	887	986	1.14	1063	1057	1.32	1232	1128	1.48	1382	1201	1.61	1503	1277	1.70	1584	1337	1.97	1834	1420	2.15	2000	1513	2.36	2196	
2600	934	1.05	980	1009	1.24	1157	1080	1.42	1325	1151	1.58	1475	1223	1.71	1596	1299	1.80	1677	1358	2.07	1928	1440	2.25	2094	1534	2.46	2290	
2700	958	1.16	1077	1032	1.35	1254	1104	1.53	1422	1175	1.69	1572	1247	1.82	1693	1323	1.90	1774	1379	2.17	2026	1462	2.35	2192	1556	2.56	2388	
2800	982	1.26	1178	1057	1.45	1355	1128	1.63	1524	1199	1.80	1674	1271	1.92	1794	1348	2.01	1875	1402	2.28	2128	1485	2.46	2294	1578	2.67	2490	
2900	1007	1.38	1283	1082	1.57	1460	1153	1.75	1629	1224	1.91	1779	1297	2.04	1899	1373	2.12	1980	1425	2.40	2236	1508	2.58	2402	1602	2.79	2598	
3000	1033	1.49	1392	1108	1.68	1569	1179	1.86	1737	1250	2.02	1887	1322	2.15	2008	1399	2.24	2089	1450	2.52	2348	1532	2.70	2515	1626	2.91	2710	
3100	1060	1.61	1504	1134	1.80	1681	1206	1.98	1850	1277	2.15	1999	1349	2.27	2120	1400	2.49	2319	1474	2.65	2467	1557	2.82	2633	1651	3.03	2829	
3200	1087	1.74	1620	1162	1.93	1797	1233	2.11	1965	1304	2.27	2115	1357	2.47	2303	1426	2.62	2443	1500	2.78	2590	1583	2.96	2756	1676	3.17	2952	
3300	1115	1.87	1739	1189	2.06	1916	1261	2.24	2084	1318	2.46	2291	1383	2.61	2433	1451	2.76	2572	1526	2.92	2719	1608	3.10	2886	1702	3.31	3081	
3400	1143	2.00	1861	1218	2.19	2038	1279	2.44	2270	1344	2.60	2426	1409	2.75	2568	1478	2.90	2707	1552	3.06	2854	1635	3.24	3021	1729	3.45	3216	
3500	1172	2.13	1986	1246	2.32	2163	1306	2.59	2411	1371	2.75	2566	1436	2.91	2708	1505	3.06	2848	1579	3.21	2995	1662	3.39	3161	1762	3.66	3411	
3600	1201	2.27	2114	1267	2.55	2377	1334	2.74	2557	1398	2.91	2713	1464	3.06	2855	1532	3.21	2994	1606	3.37	3142	1695	3.57	3331	1801	3.93	3661	
3700	1223	2.48	2314	1295	2.71	2530	1361	2.91	2710	1426	3.07	2865	1491	3.23	3007	1560	3.38	3147	1647	3.51	3293	1746	3.77	3501	1851	4.27	3951	
3800	1251	2.65	2473	1323	2.88	2688	1389	3.08	2868	1454	3.24	3023	1519	3.40	3165	1600	3.59	3307	1698	3.74	3464	1805	4.03	3711	1911	4.57	4201	
3900	1280	2.83	2636	1351	3.06	2852	1418	3.25	3032	1487	3.46	3133	1551	3.57	3327	1650	3.79	3477	1797	4.01	3644	1874	4.29	3881	1981	4.91	4601	
4000	1308	3.01	2806	1380	3.24	3021	1446	3.43	3201	1516	3.67	3293	1600	3.81	3507	1720	4.03	3667	1874	4.29	3881	1981	4.57	4201	2091	5.27	4951	

High Horsepower Option Required

**TABLE 24: DF102 (8-1/2 TON) DOWN SHOT BLOWER PERFORMANCE**

CFM	External Static Pressure																										
	0.2			0.4			0.6			0.8			1.0			1.2			1.4			1.6			1.8		
	RPM	BHP	Watts	RPM	BHP	Watts	RPM	BHP	Watts	RPM	BHP	Watts	RPM	BHP	Watts	RPM	BHP	Watts	RPM	BHP	Watts	RPM	BHP	Watts	RPM	BHP	Watts
2000	842	0.46	431	913	0.69	647	980	0.89	827	1044	1.05	982	1110	1.21	1124	1178	1.36	1263	1253	1.51	1411	1335	1.69	1577	1429	1.90	1773
2100	856	0.55	513	927	0.78	728	993	0.97	908	1058	1.14	1064	1123	1.29	1206	1192	1.44	1345	1266	1.60	1492	1349	1.78	1658	1443	1.99	1854
2200	871	0.64	595	942	0.87	810	1009	1.06	990	1074	1.23	1146	1139	1.38	1288	1207	1.53	1427	1282	1.69	1574	1364	1.87	1741	1458	2.08	1936
2300	888	0.73	679	959	0.96	894	1026	1.15	1074	1091	1.32	1230	1156	1.47	1372	1224	1.62	1511	1299	1.78	1658	1381	1.96	1824	1475	2.17	2020
2400	906	0.82	765	978	1.05	980	1044	1.24	1160	1109	1.41	1316	1174	1.56	1458	1243	1.71	1597	1317	1.87	1745	1400	2.05	1911	1493	2.26	2107
2500	926	0.92	855	997	1.15	1070	1064	1.34	1250	1129	1.51	1406	1194	1.66	1548	1262	1.81	1687	1340	2.02	1883	1415	2.13	1990	1494	2.21	2063
2600	947	1.02	948	1018	1.25	1164	1085	1.44	1344	1149	1.61	1499	1215	1.76	1641	1283	1.91	1780	1362	2.13	1990	1436	2.25	2096	1515	2.33	2170
2700	969	1.12	1046	1040	1.35	1261	1106	1.55	1441	1171	1.71	1597	1236	1.87	1739	1305	2.02	1878	1384	2.26	2102	1459	2.37	2209	1538	2.45	2282
2800	991	1.23	1149	1062	1.46	1364	1129	1.66	1544	1194	1.82	1700	1259	1.98	1842	1328	2.13	1981	1408	2.38	2221	1483	2.50	2328	1562	2.58	2401
2900	1015	1.35	1256	1086	1.58	1471	1152	1.77	1651	1217	1.94	1807	1283	2.09	1949	1362	2.37	2207	1434	2.52	2346	1508	2.63	2452	1587	2.71	2526
3000	1039	1.47	1369	1110	1.70	1584	1177	1.89	1764	1241	2.06	1920	1307	2.21	2062	1388	2.51	2338	1460	2.66	2477	1534	2.77	2583	1613	2.85	2657
3100	1064	1.60	1487	1135	1.83	1702	1201	2.02	1882	1266	2.19	2038	1345	2.47	2307	1415	2.66	2475	1487	2.80	2614	1561	2.92	2721	1641	3.00	2794
3200	1089	1.73	1611	1160	1.96	1826	1227	2.15	2006	1292	2.32	2161	1373	2.63	2450	1443	2.81	2619	1515	2.96	2757	1590	3.07	2864	1669	3.15	2937
3300	1115	1.87	1740	1186	2.10	1955	1253	2.29	2135	1318	2.46	2291	1402	2.79	2600	1472	2.97	2768	1544	3.12	2907	1619	3.23	3013	1698	3.31	3087
3400	1142	2.01	1875	1213	2.24	2090	1279	2.44	2270	1361	2.74	2558	1432	2.96	2755	1502	3.14	2924	1574	3.29	3062	1648	3.40	3169	-----	-----	-----
3500	1168	2.16	2016	1240	2.39	2231	1306	2.59	2411	1392	2.92	2720	1462	3.13	2917	1533	3.31	3086	-----	-----	-----	-----	-----	-----	-----	-----	-----
3600	1196	2.32	2162	1267	2.55	2377	1351	2.86	2663	1423	3.10	2887	1494	3.31	3085	-----	-----	-----	-----	-----	-----	-----	-----	-----	-----	-----	-----
3700	1223	2.48	2314	1295	2.71	2530	1383	3.04	2837	1455	3.28	3061	-----	-----	-----	-----	-----	-----	-----	-----	-----	-----	-----	-----	-----	-----	-----
3800	1251	2.65	2473	1341	2.97	2767	1416	3.24	3016	-----	-----	-----	-----	-----	-----	-----	-----	-----	-----	-----	-----	-----	-----	-----	-----	-----	-----
3900	1280	2.83	2636	1374	3.17	2952	1450	3.43	3202	-----	-----	-----	-----	-----	-----	-----	-----	-----	-----	-----	-----	-----	-----	-----	-----	-----	-----
4000	1328	3.08	2870	1408	3.37	3143	-----	-----	-----	-----	-----	-----	-----	-----	-----	-----	-----	-----	-----	-----	-----	-----	-----	-----	-----	-----	-----
4100	1363	3.29	3067	-----	-----	-----	-----	-----	-----	-----	-----	-----	-----	-----	-----	-----	-----	-----	-----	-----	-----	-----	-----	-----	-----	-----	-----

Optional Drive Required

**TABLE 25: DF120 (10 TON) DOWN SHOT BLOWER PERFORMANCE**

CFM	External Static Pressure																				
	0.2		0.4		0.6		0.8		1.0		1.2		1.4		1.6						
	RPM	BHP	Watts	RPM	BHP	Watts	RPM	BHP	Watts	RPM	BHP	Watts	RPM	BHP	Watts	RPM	BHP	Watts			
3000	741	1.21	1128	814	1.34	1248	880	1.50	1400	935	1.68	1564	981	1.86	1732	1018	2.03	1893	1047	2.17	2026
3100	758	1.26	1178	829	1.41	1312	892	1.58	1473	945	1.76	1643	990	1.95	1815	1025	2.12	1976	1053	2.26	2107
3200	775	1.32	1234	843	1.48	1381	904	1.66	1550	956	1.85	1726	998	2.04	1900	1032	2.21	2061	1060	2.35	2190
3300	792	1.39	1298	858	1.56	1456	916	1.75	1632	966	1.94	1812	1007	2.13	1989	1040	2.31	2149	1066	2.44	2275
3400	809	1.47	1369	872	1.65	1537	929	1.84	1719	976	2.04	1902	1015	2.23	2080	1047	2.40	2239	1072	2.53	2361
3500	826	1.55	1447	887	1.74	1623	941	1.94	1810	986	2.14	1995	1024	2.33	2174	1054	2.50	2331	1078	2.61	2448
3600	843	1.64	1532	901	1.84	1715	953	2.04	1905	997	2.24	2092	1033	2.44	2270	1062	2.60	2425	1084	2.71	2545
3700	860	1.74	1624	916	1.94	1812	965	2.15	2005	1007	2.35	2193	1041	2.54	2370	1069	2.71	2522	1090	2.82	2642
3800	877	1.85	1723	930	2.05	1915	977	2.26	2109	1017	2.46	2297	1050	2.65	2473	1076	2.81	2621	1096	2.92	2748
3900	894	1.96	1829	945	2.17	2023	990	2.38	2218	1027	2.58	2405	1059	2.77	2578	1083	2.91	2700	1102	3.02	2875
4000	911	2.08	1943	959	2.29	2138	1002	2.50	2331	1038	2.70	2516	1067	2.88	2686	1090	3.01	2852	1108	3.12	3000
4100	928	2.21	2063	974	2.42	2257	1014	2.63	2449	1048	2.82	2631	1076	3.00	2797	1097	3.10	2929	1115	3.23	3125
4200	945	2.35	2190	988	2.56	2383	1026	2.76	2571	1058	2.95	2749	1084	3.09	2958	1104	3.19	3054	1122	3.34	3250
4300	962	2.49	2324	1003	2.70	2514	1038	2.89	2697	1068	3.08	2871	1092	3.18	3087	1112	3.28	3183	1130	3.45	3375
4400	979	2.65	2466	1017	2.84	2650	1050	3.03	2828	1079	3.21	2996	1100	3.37	3216	1120	3.37	3316	1138	3.56	3500
4500	996	2.80	2614	1032	3.00	2792	1063	3.18	2963	1090	3.30	3103	1108	3.46	3249	1128	3.46	3449	1146	3.67	3625
4600	1013	2.97	2770	1046	3.15	2940	1075	3.33	3103	1108	3.45	3253	1116	3.55	3382	1136	3.55	3582	1154	3.78	3750
4700	1030	3.15	2932	1061	3.32	3094	1089	3.50	3253	1120	3.60	3407	1124	3.64	3496	1144	3.64	3726	1162	3.89	3875
4800	1047	3.33	3102	1075	3.49	3253	1103	3.65	3453	1132	3.75	3560	1132	3.74	3684	1152	3.74	3884	1170	4.00	4000
4900	1065	3.52	3278	1089	3.82	3628	1117	3.90	3753	1146	3.84	3860	1146	3.84	3984	1160	3.84	4008	1178	4.11	4125
5000	1082	3.71	3462	1103	4.00	3816	1131	4.05	3998	1160	4.10	4100	1160	4.10	4220	1170	4.10	4220	1180	4.21	4250

High Horsepower Option Required

Motor Efficiency 0.8

Std HP Motor2

**TABLE 26: ADDITIONAL STATIC RESISTANCE DF078, 120**

CFM	Cooling Only*	Economizer† ‡	Electric Heat KW†				
			9	18	24	36	54
1900	0.06	0.02	0.05	0.06	0.07	0.08	0.10
2100	0.07	0.02	0.06	0.07	0.08	0.09	0.11
2300	0.08	0.02	0.07	0.08	0.09	0.10	0.13
2500	0.09	0.02	0.08	0.09	0.10	0.11	0.14
2700	0.11	0.03	0.09	0.10	0.12	0.13	0.16
2900	0.12	0.03	0.10	0.11	0.13	0.14	0.18
3100	0.14	0.03	0.12	0.13	0.15	0.16	0.20
3300	0.16	0.03	0.13	0.14	0.17	0.18	0.22
3500	0.18	0.04	0.15	0.16	0.19	0.20	0.24
3700	0.20	0.04	0.17	0.18	0.21	0.22	0.26
3900	0.23	0.04	0.19	0.20	0.23	0.24	0.28
4100	0.25	0.04	0.21	0.22	0.25	0.26	0.31
4300	0.28	0.05	0.23	0.24	0.28	0.29	0.34
4500	0.30	0.05	0.25	0.26	0.30	0.31	0.37
4700	0.33	0.05	0.28	0.29	0.33	0.34	0.40
4900	0.36	0.05	0.30	0.31	0.35	0.37	0.43
5100	0.39	0.06	0.33	0.34	0.38	0.40	0.46

\* Add these resistance values to the available static resistance in the respective Blower Performance Tables.

† Deduct these resistance values from the available external static pressure shown in the respective Blower Performance Table.

‡ The pressure drop through the economizer is greater for 100% outdoor air than for 100% return air. If the resistance of the return air duct system is less than 0.25 IWG, the unit will deliver less CFM during full economizer operation.

**TABLE 27: ADDITIONAL STATIC RESISTANCE DF090, 102**

CFM	Cooling Only*	Economizer† ‡	Electric Heat KW†				
			9	18	24	36	54
1900	-0.004	0.07	0.05	0.06	0.07	0.08	0.1
2100	0.01	0.09	0.06	0.07	0.08	0.09	0.11
2300	0.01	0.11	0.07	0.08	0.09	0.1	0.13
2500	0.02	0.13	0.08	0.09	0.1	0.11	0.14
2700	0.03	0.16	0.09	0.1	0.12	0.13	0.16
2900	0.04	0.18	0.1	0.11	0.13	0.14	0.18
3100	0.05	0.20	0.12	0.13	0.15	0.16	0.2
3300	0.06	0.22	0.13	0.14	0.17	0.18	0.22
3500	0.07	0.24	0.15	0.16	0.19	0.2	0.24
3700	0.08	0.27	0.17	0.18	0.21	0.22	0.26
3900	0.09	0.29	0.19	0.2	0.23	0.24	0.28
4100	0.09	0.31	0.21	0.22	0.25	0.26	0.31
4300	0.10	0.33	0.23	0.24	0.28	0.29	0.34

\* Deduct these resistance values to the available static resistance in the respective Blower Performance Tables.

† Deduct these resistance values from the available external static pressure shown in the respective Blower Performance Table.

‡ The pressure drop through the economizer is greater for 100% outdoor air than for 100% return air. If the resistance of the return air duct system is less than 0.25 IWG, the unit will deliver less CFM during full economizer operation.

**TABLE 28: ELECTRIC HEAT MINIMUM SUPPLY AIR CFM**

HEATER		UNIT MODEL SIZE (NOMINAL TONS)			
kW	VOLTAGE	078 (6.5)	090 (7.5)	102 (8.5)	120 (10)
		MINIMUM SUPPLY AIR CFM			
9	208/230	1950	2250	2550	N/A
18		1950	2250	2550	3000
24		1950	2250	2550	3000
36		1950	2250	2550	3000
54		N/A	N/A	N/A	3500
9	480	1950	2250	2550	N/A
18		1950	2250	2550	3000
24		1950	2250	2550	3000
36		1950	2250	2550	3000
54		N/A	N/A	N/A	3000
9	600	1950	2250	2550	N/A
18		1950	2250	2550	3000
24		1950	2250	2550	3000
36		1950	2250	2550	3000
54		N/A	N/A	N/A	3500

**TABLE 29: INDOOR BLOWER SPECIFICATIONS**

MODEL	MOTOR					MOTOR SHEAVE			BLOWER SHEAVE			BELT
	HP	RPM	Eff.	SF	Frame	Datum Dia. (in.)	Bore (in.)	Model	Datum Dia. (in.)	Bore (in.)	Model	
DF078	1-1/2	1725	80%	1.15	56	3.4 - 4.4	7/8	1VM50	9.5	1	AK99	A58
	2	1725	80%	1.15	56	3.4 - 4.4	7/8	1VM50	7.5	1	AK79	A55
DF090	2	1725	80%	1.15	56	3.4 - 4.4	7/8	1VM50	6.5	1	AK69	A49
	3	1725	80%	1.15	56	3.4 - 4.4	7/8	1VM50	6.0	1	AK64	A49
DF102	3	1725	80%	1.15	56	3.4 - 4.4	7/8	1VM50	6.0	1	AK64	A49
	3	1725	80%	1.15	56	3.4 - 4.4	7/8	1VM50	5.7	1	AK61	A49
DF120	2	1725	80%	1.15	56	3.4 - 4.4	7/8	1VM50	8.5	1	AK89	A56
	3	1725	80%	1.15	56	3.4 - 4.4	7/8	1VM50	7.0	1	AK74	A54

**TABLE 30: POWER EXHAUST SPECIFICATIONS**

POWER EXHAUST MODEL	VOLT	PHASE	MOTOR			ELECTRICAL			FUSE SIZE	CFM @ 0.1 ESP
			HP	RPM*	QTY	LRA	FLA	MCA		
2PE0473225	208/230	1	0.75	1075	1	24.9	5.0	6.3	10	3,800
2PE0473246	460	1				N/A	2.2	2.8	5	
2PE0473258	575	1				N/A	1.5	1.9	4	

\* Motors are multi-tapped and factory wired for high speed.

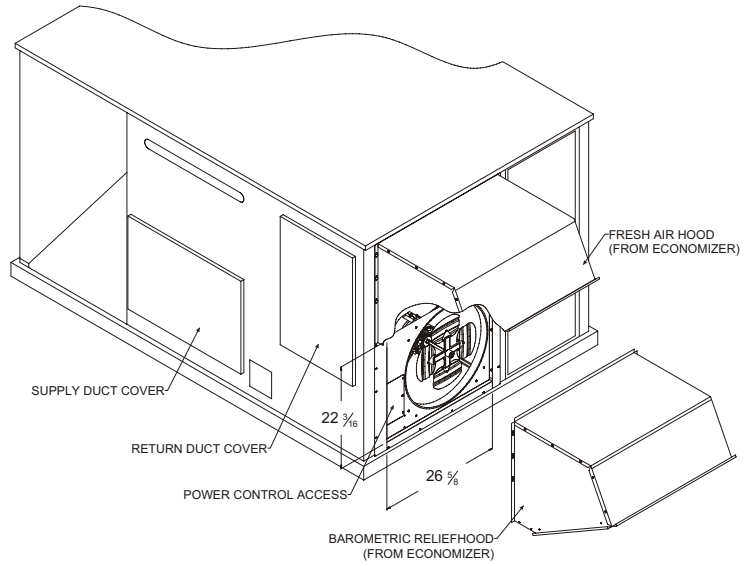

**FIGURE 2 - POWER EXHAUST ACCESSORY DOWNFLOW APPLICATION**

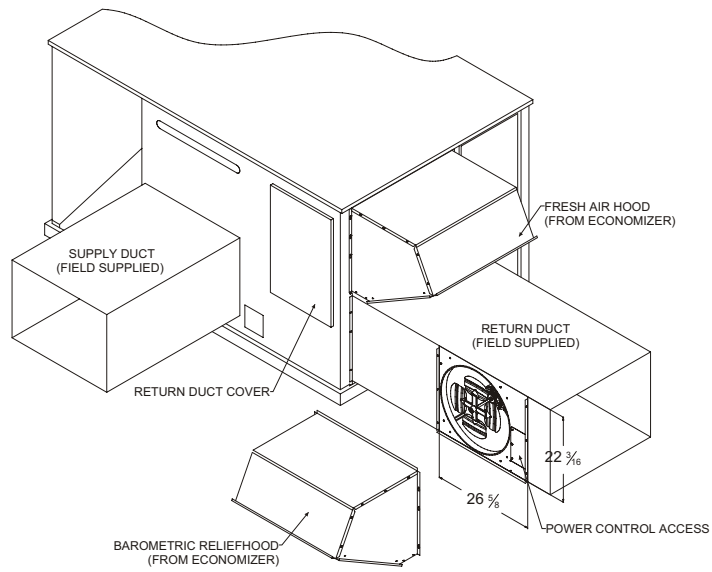

**FIGURE 3 - POWER EXHAUST ACCESSORY HORIZONTAL APPLICATION**

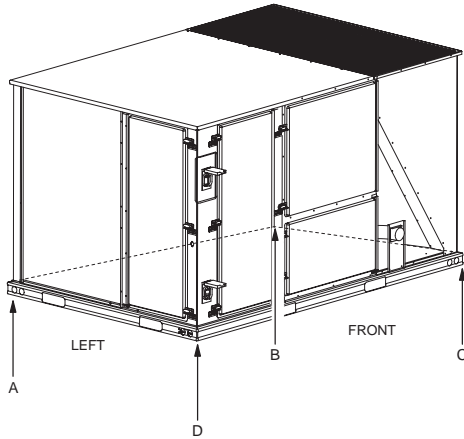

FIGURE 4 - UNIT 4 POINT LOAD

TABLE 31: 4 POINT LOAD WEIGHT

Model	Location (lbs.)*			
	A	B	C	D
DF078	231	197	288	337
DF090	195	146	228	306
DF102	197	147	230	309
DF120	260	222	324	379

\* Weights include largest heating option.

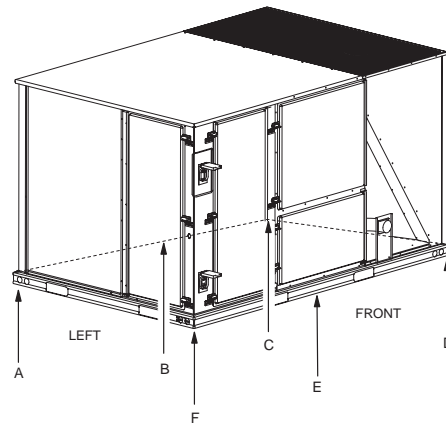

FIGURE 6 - UNIT 6 POINT LOAD

TABLE 32: 6 POINT LOAD WEIGHT

Model	Locations (lbs.)					
	A	B	C	D	E	F
DF078	158	142	128	187	207	231
DF090	137	112	93	145	175	214
DF102	138	113	93	146	176	216
DF120	178	160	144	210	233	260

TABLE 33: UNIT WEIGHT

Model	Shipping* Weight (lbs.)	Operating Weight (lbs.)
DF078	1058	1053
DF090	875	870
DF102	888	883
DF120	1190	1185
ECON.	85	84
PE	150	148
GAS HEAT†	110	100
ELEC. HEAT‡	49	49

\* Weights include largest heating option.

† 8 tube gas section.

‡ 54kW heater.

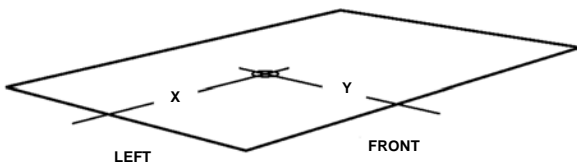

Unit Model Number	X	Y
DF078	47 1/2	25 1/2
DF090	38	23
DF102	38	23
DF120	47 1/2	25 1/2

FIGURE 5 - UNIT CENTER OF GRAVITY

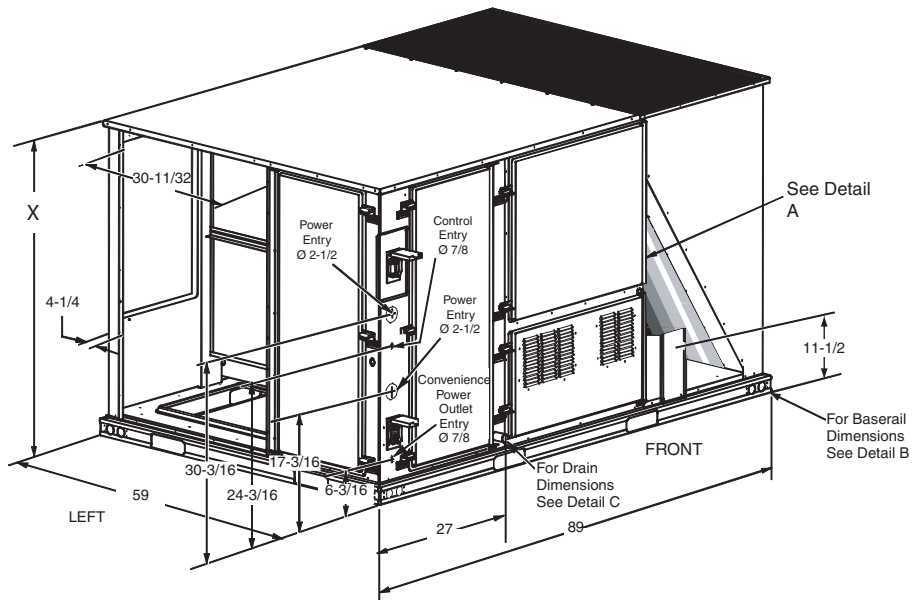
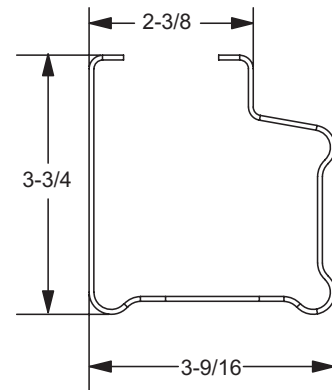

FIGURE 7 - UNIT DIMENSIONS

TABLE 34: UNIT HEIGHT

Unit Model Number	X
DF078	50 3/4
DF090	42
DF102	42
DF120	50 3/4

DETAIL B



DETAIL A

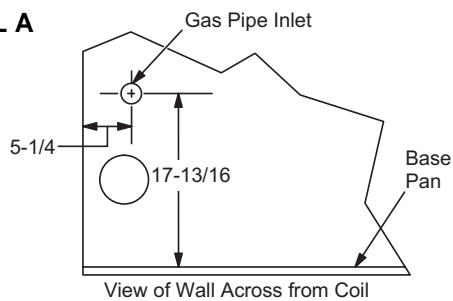

DETAIL C

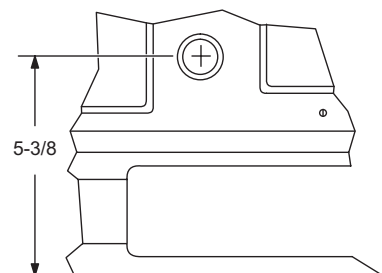
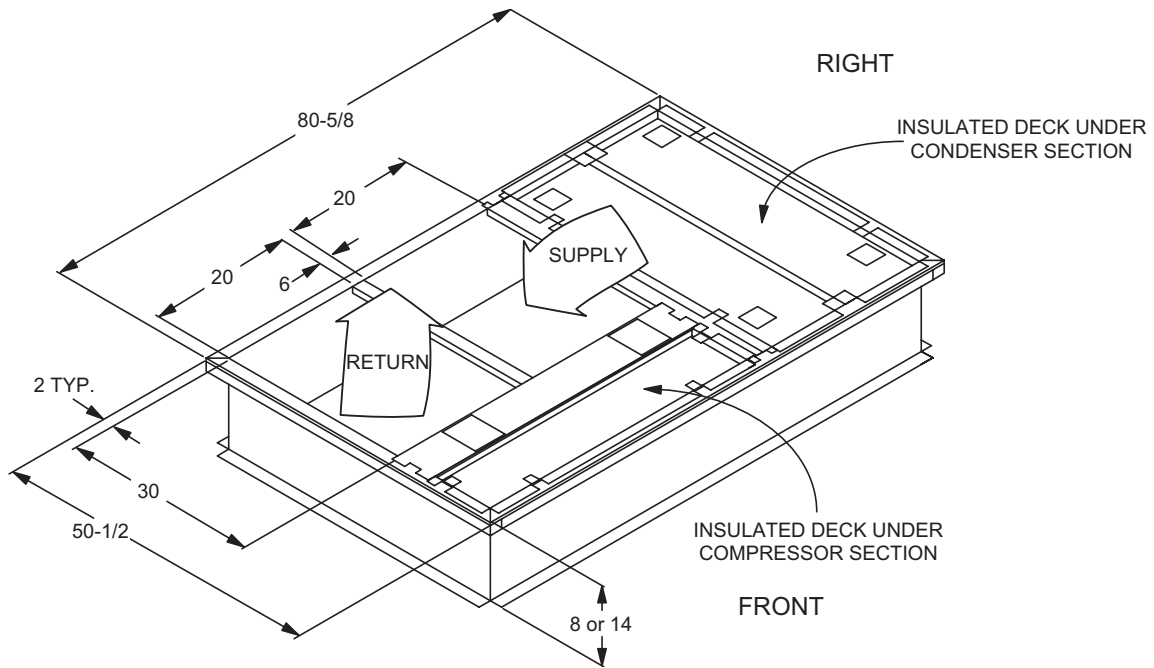

TABLE 35: UNIT CLEARANCES

Top*	72"	Right	12"
Front	36"	Left	36"
Rear†	36"	Bottom‡	0"

- \* Units must be installed outdoors. Overhanging structure or shrubs should not obstruct condenser air discharge outlet.
- † To remove the slide-out drain pan, a rear clearance of 60" is required. If space is unavailable, the drain pan can be removed through the front by separating the corner wall.
- ‡ Units may be installed on combustible floors made from wood or class A, B or C roof covering materials.



**FIGURE 8 - PREDATOR® ROOF CURB DIMENSIONS**

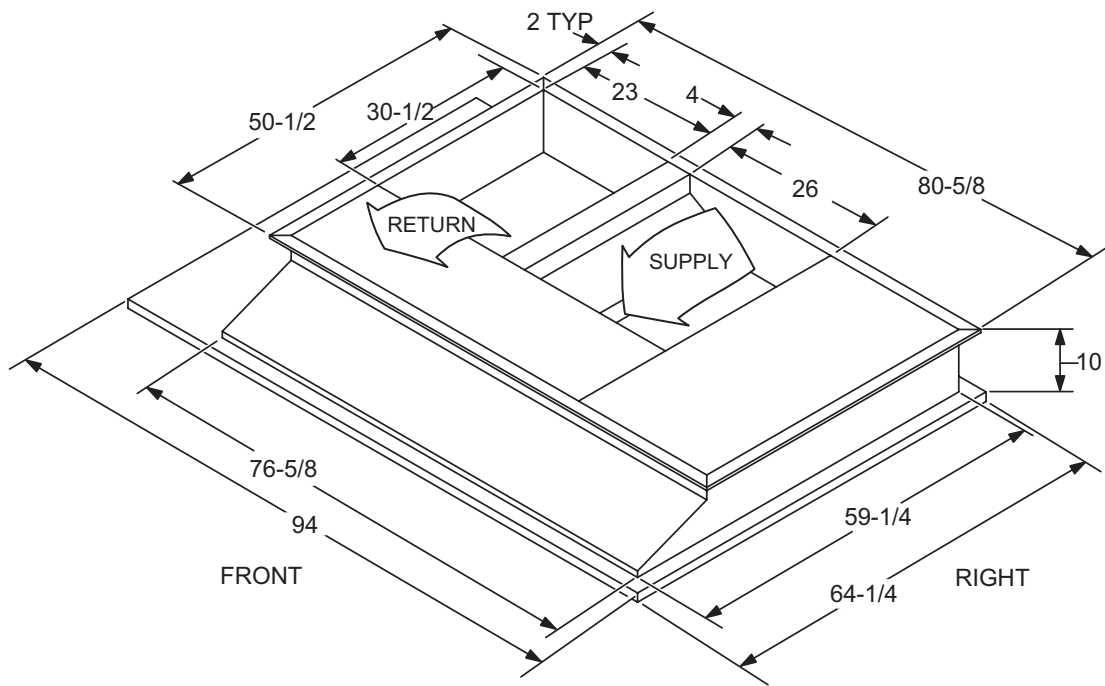

**FIGURE 9 - SUNLINE™ TO PREDATOR® TRANSITION ROOF CURBS**

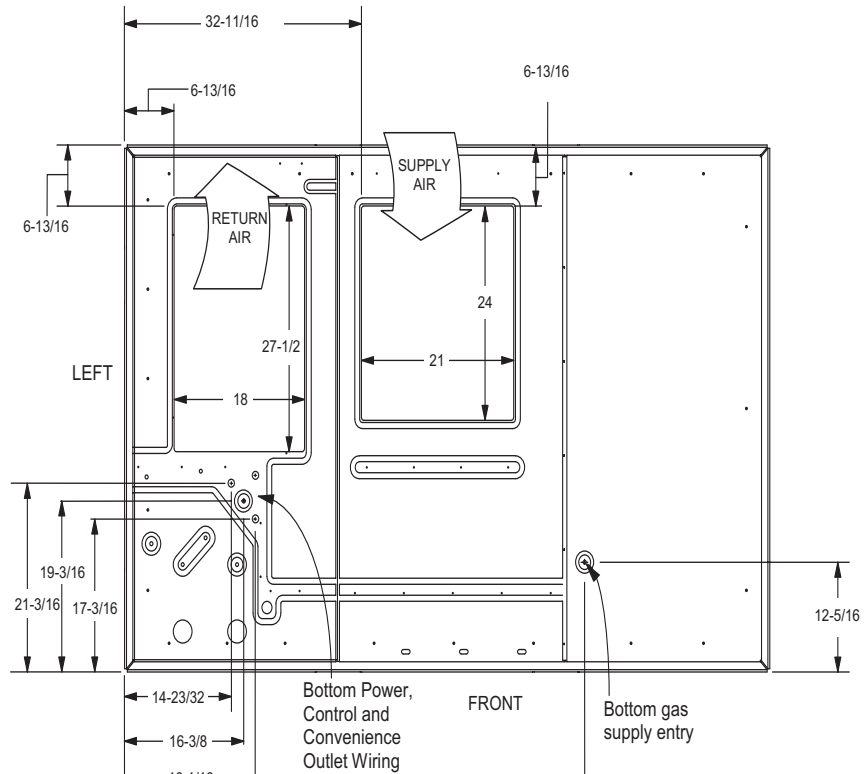

FIGURE 10 - BOTTOM DUCT OPENINGS (FROM ABOVE)

REAR DUCT DIMENSIONS

CABINET SIZE	DIMENSION		
	"A"	"B"	"C"
50 3/4"	28 1/4	18 1/16	28 1/4
42"	27 3/4	12 1/16	27 1/2

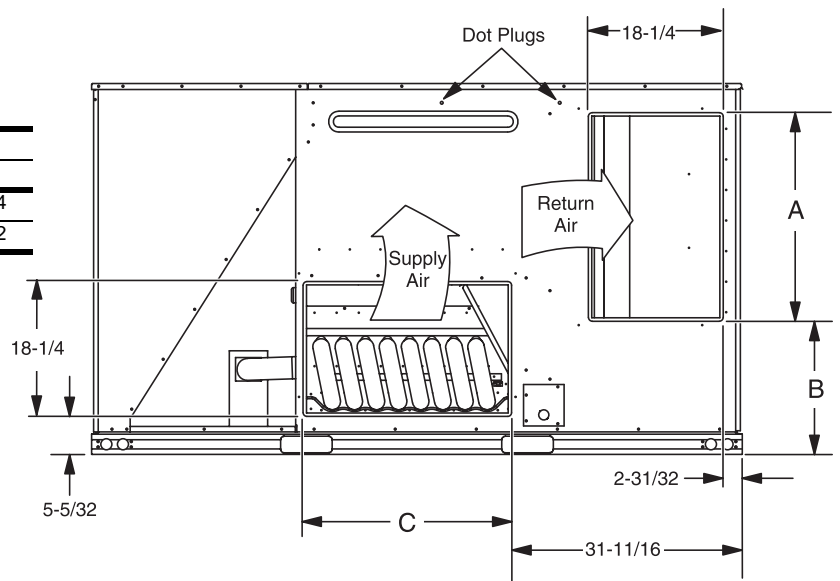
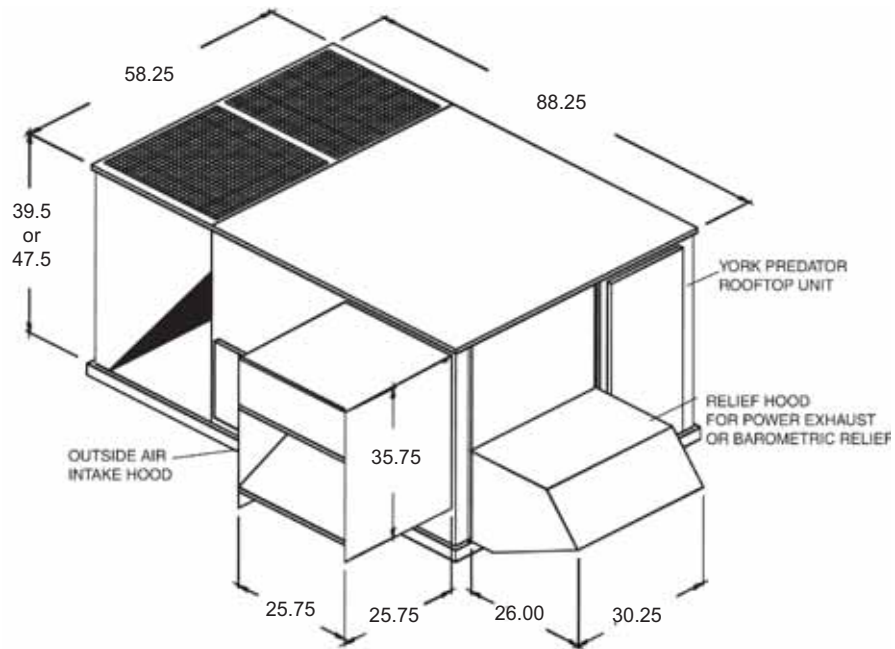

FIGURE 11 - REAR DUCT DIMENSIONS



**FIGURE 12 - DOWNFLOW ECONOMIZER HOOD DETAIL**



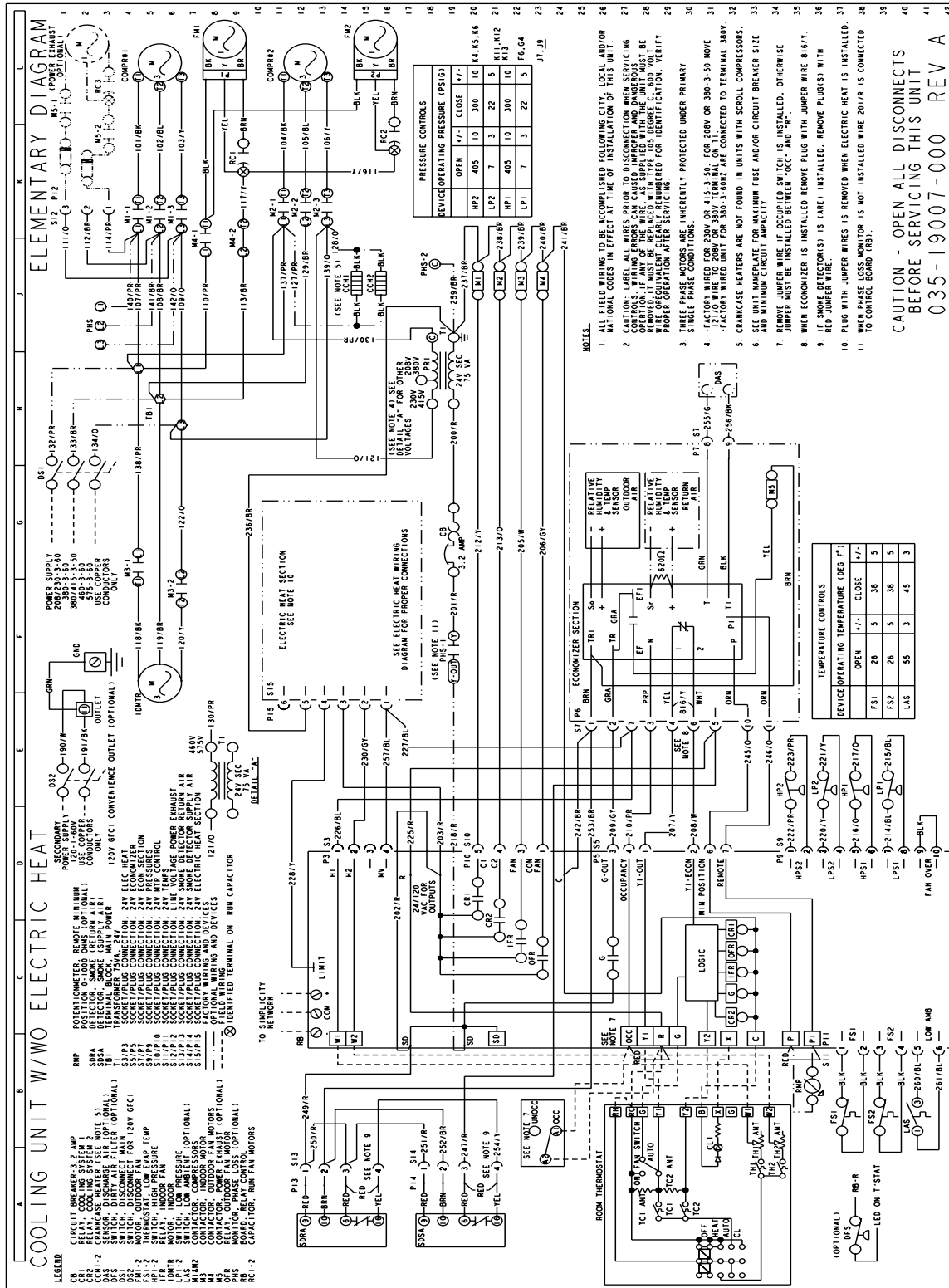

FIGURE 14 - COOLING UNIT WITH/WITHOUT ELECTRIC HEAT WIRING DIAGRAM



## GUIDE SPECIFICATIONS

### PREDATOR® DF 078, 090, 102 & 120 10.4 EER

#### GENERAL

Units shall be manufactured by York International Unitary Products Group in an ISO 9001 certified facility. YORK® DF Predator® units are convertible single packages with a common footprint cabinet and common roof curb for all 6-1/2 through 10 ton models. All units have two compressors with independent refrigeration circuits to provide 2 stages of cooling. The units were designed for light commercial applications and can be easily installed on a roof curb, slab, or frame. All Predator® units are self-contained and assembled on rigid full perimeter base rails allowing for 3-way forklift access and overhead rigging. Every unit is completely charged, wired, piped, and tested at the factory to provide a quick and easy field installation. All units are convertible between side and down airflow. Independent economizer designs are used on side and down discharge applications, as well as all tonnage sizes. Predator® units are available in the following configurations: cooling only, cooling with electric heat, and cooling with gas heat. Electric heaters are available as factory-installed options or field-installed accessories.

#### DESCRIPTION

Units shall be factory assembled, single package, (Elec/Elec, Gas/Elec), designed for outdoor installation. Units shall have a minimum EER of 10.4. They shall have built in field convertible duct connections for down discharge supply/return or horizontal discharge supply/return and be available with factory installed options or field installed accessories. The units shall be factory wired, piped and charged with R-22 refrigerant and factory tested prior to shipment. All unit wiring shall be both numbered and color coded. The cooling performance shall be rated in accordance with DOE and ARI test procedures. Units shall be CSA certified to ANSI Z21.47 and UL 1995/CAN/CSA No. 236-M90 standards.

#### UNIT CABINET

Unit cabinet shall be constructed of G90 galvanized steel with exterior surfaces coated with a non-chalking, powder paint finish, certified at 1000 hours salt spray test per ASTM-B117 standards. Indoor blower sections shall be insulated with up to 1" thick insulation coated on the airside. Aluminum foil faced insulation shall be used in the unit's compartments and be fastened to prevent insulation from entering the air stream. Cabinet doors shall be hinged with toolless access for easy servicing and maintenance. Full perimeter base rails shall be provided to assure reliable transit of equipment, overhead rigging, fork truck access and proper sealing on roof curb applications. Disposable 2" filters shall be furnished and be accessible through hinged access door. Fan performance measuring ports shall be provided on the outside of the cabinet to allow accurate air measurements of evaporator

fan performance without removing panels or creating bypass of the coils. Condensate pan shall be slide out design, constructed of a non corrosive material, internally sloped and conforming to ASHRAE 62-B9 standards. Condensate connection shall be a minimum of 3/4" I.D. female and be rigid mount connection.

#### INDOOR (EVAPORATOR) FAN ASSEMBLY

Fan shall be a belt drive assembly and include an adjustable pitch motor pulley. Job site selected brake horsepower shall not exceed the motors nameplate horsepower rating plus the service factor. Units shall be designed to operate within the service factor. Fan wheel shall be double inlet type with forward curve blades, dynamically balanced to operate smoothly throughout the entire range of operation. Airflow design shall be constant volume. Bearings shall be sealed and permanently lubricated for longer life and no maintenance. Entire blower assembly and motor shall be slide out design.

#### OUTDOOR (CONDENSER) FAN ASSEMBLY

The outdoor fans shall be of the direct drive type, discharge air vertically, have aluminum blades riveted to corrosion resistant steel spider brackets and shall be dynamically balanced for smooth operation. The outdoor fan motors shall have permanently lubricated bearings internally protected against overload conditions and staged independently. A cleaning window shall be provided on two sides of the units for coil cleaning.

#### REFRIGERANT COMPONENTS

##### Compressors:

- A. Shall be fully hermetic type, direct drive, internally protected with internal high-pressure relief and over temperature protection. The hermetic motor shall be suction gas cooled and have a voltage range of + or - 10% of the unit nameplate voltage.
- B. Shall have internal spring isolation and sound muffling to minimize vibration and noise, and be externally isolated on a dedicated, independent mounting.

##### Coils:

- A. Evaporator and condenser coils shall have aluminum plate fins mechanically bonded to seamless internally enhanced copper tubes with all joints brazed. Special Phenolic coating shall be available as a factory option.
- B. Evaporator and condenser coils shall be of the direct expansion, draw-thru design.

Refrigerant Circuit and Refrigerant Safety Components shall include:

- A. Independent fixed-orifice or thermally operated expansion devices.
- B. Solid core filter drier/strainer to eliminate any moisture or foreign matter.
- C. Accessible service gage connections on both suction and discharge lines to charge, evacuate, and measure refrigerant pressure during any necessary servicing or troubleshooting, without losing charge.
- D. The unit shall have two independent refrigerant circuits, equally split in 50% capacity increments.

#### Unit Controls:

- A. Unit shall be complete with self-contained low-voltage control circuit protected by a resettable circuit breaker on the 24-volt transformer side.
- B. Unit shall incorporate a lockout circuit which provides reset capability at the space thermostat or base unit should any of the following standard safety devices trip and shut off compressor:
  - C. Loss-of-charge/Low-pressure switch.
    - (1) High-pressure switch.
    - (2) Freeze-protection thermostat, evaporator coil. If any of the above safety devices trip, an LED (light-emitting diode) indicator shall flash a diagnostic code that indicates which safety switch has tripped.
- D. Unit shall incorporate "AUTO RESET" compressor over temperature, over current protection.
- E. Unit shall operate with conventional thermostat designs and have a low voltage terminal strip for easy hook-up.
- F. Unit control board shall have on-board diagnostics and fault code display.
- G. Standard controls shall include anti-short cycle and low voltage protection, and permit cooling operation down to 0 °F.
- H. Control board shall monitor each refrigerant safety switch independently.
- I. Control board shall retain last 5 fault codes in non-volatile memory, which will not be lost in the event of a power loss.

#### **GAS HEATING SECTION (IF EQUIPPED)**

Heat exchanger and exhaust system shall be constructed of aluminized steel and shall be designed with induced draft combustion with post purge logic, energy saving direct spark ignition, and redundant main gas valve. The heat exchanger shall be of the tubular type, constructed of T1-40 aluminized steel for corrosion resistance and allowing minimum mixed air entering temperature of 40 °F. Burners shall be of the in-

shot type, constructed of aluminum-coated steel. All gas piping shall enter the unit cabinet at a single location, through either the side or bottom, without any field modifications. An integrated control board shall provide timed control of evaporator fan functioning and burner ignition. Heating section shall be provided with the following minimum protection:

- A. Primary and auxiliary high-temperature limit switches.
- B. Induced draft pressure sensor.
- C. Flame roll out switch (manual reset).
- D. Flame proving controls. Unit shall have two independent stages of capacity (60% 1<sup>st</sup> stage, 100% 2<sup>nd</sup> stage).

#### **ELECTRIC HEATING SECTION (IF EQUIPPED)**

An electric heating section, with nickel chromium elements, shall be provided in a range of 9 thru 54 KW, offering two states of capacity all sizes. The heating section shall have a primary limit control(s) (automatic reset) to prevent the heating element system from operating at an excessive temperature. The Heating Section assembly shall slide out of the unit for easy maintenance and service. Units with Electric Heating Sections shall be wired for a single point power supply with branch circuit fusing (where required).

#### **UNIT OPERATING CHARACTERISTICS**

Unit shall be capable of starting and running at 125 °F outdoor temperature, exceeding maximum load criteria of ARI Standard 210/240. The compressor, with standard controls, shall be capable of operation down to 0 °F outdoor temperature. Unit shall be provided with fan time delay to prevent cold air delivery before heat exchanger warms up. (Gas heat only)

**ELECTRICAL REQUIREMENTS** - All unit power wiring shall enter unit cabinet at a single factory provided location and be capable of side or bottom entry to minimize roof penetrations and avoid unit field modifications. Separate side and bottom openings shall be provided for the control wiring.

**STANDARD LIMITED WARRANTIES** - Compressor - 5 Years, Heat Exchanger - 10 Years, Elect. Heat Elem. - 5 Years, Parts - 1 Year

**FACTORY INSTALLED OPTIONAL OUTDOOR AIR** (Shall be made available by either/or):

1. **ELECTRONIC ENTHALPY AUTOMATIC ECONOMIZER** - Outdoor and return air dampers that are interlocked and positioned by a fully-modulating, spring-return damper actuator. The maximum leakage rate for the outdoor air intake dampers shall not exceed 2% when dampers are fully closed and operating against a pressure differential of 0.5 IWG. A unit-mounted potentiometer shall be provided to adjust the outdoor and return air damper assembly to take in outdoor air to meet the minimum ventilation requirement of the conditioned space during normal operation. During economizer operation, a mixed-air temperature control shall modulate the

outdoor and return air damper assembly to prevent the supply air temperature from dropping below 55 °F. Changeover from compressor to economizer operation shall be provided by an integral electronic enthalpy control that feeds input into the basic module. The outdoor intake opening shall be covered with a rain hood that matches the exterior of the unit. Water eliminator/filters shall be provided. Simultaneous economizer/compressor operation is also possible. Dampers shall fully close on power loss. Available with barometric relief or power exhaust.

2. **MOTORIZED OUTDOOR AIR DAMPERS** - Outdoor and return air dampers that are interlocked and positioned by a 2-position, spring-return damper actuator. The maximum leakage rate for the outdoor air intake dampers shall not exceed 2% when dampers are fully closed and operating against a pressure differential of 0.5 IWG. A unit-mounted potentiometer shall be provided to adjust the outdoor and return air damper assembly to take in the design CFM of outdoor air to meet the ventilation requirements of the conditioned space during normal operation. Whenever the indoor fan motor is energized, the dampers open up to one of two pre-selected positions - regardless of the outdoor air enthalpy. Dampers return to the fully closed position when the indoor fan motor is de-energized. Dampers shall fully close on power loss.

#### ADDITIONAL FACTORY INSTALLED OPTIONS

- **ALTERNATE INDOOR BLOWER MOTOR** - For applications with high restrictions, units are available with optional indoor blower motors that provide higher static output and/or higher airflow.
- **CONVENIENCE OUTLET (POWERED/NON-POWERED)** - Unit can be provided with an optional 120VAC GFCI outlet with cover on the corner of the unit housing the compressors.
- **ELECTRIC HEAT** - Electric heaters range from 9kW to 54 kW and are available in all the voltage options of the base unit.
- **PHASE MONITOR** - Designed to prevent damage in out-of-phase condition.
- **COIL GUARD** - Designed to prevent condenser coil damage.
- **BAS CONTROLS** - Include supply air sensor, return air sensor, dirty filter indicator and air proving switch.
- **DIRTY FILTER SWITCH** - This kit includes a differential pressure switch that energizes the fault light on the unit thermostat, indicating that there is an abnormally high-pressure drop across the filters.
- **BREAKER** - An HACR breaker can be factory installed on gas heat units or cooling units with electric heaters.
- **DISCONNECT SWITCH** - A disconnect can be factory installed on cooling only units, sized for the largest electric heat available.
- **STAINLESS STEEL HEAT EXCHANGER** - For applications in a corrosive environment, this option provides a full stainless steel heat exchanger assembly.
- **STAINLESS STEEL DRAIN PAN** - Provides years of trouble free operation in corrosive environments.
- **SMOKE DETECTOR** - A smoke detector can be factory mounted and wired in the supply and/or return air compartments.

#### OTHER PRE-ENGINEERED ACCESSORIES AVAILABLE

- **ROOF CURB** - 14" and 8" high, full perimeter knockdown curb, with hinged design for quick assembly.
- **BAROMETRIC RELIEF DAMPER** - (Unit Mounted - Downflow, Duct Mounted - Horizontal flow) - Contains a rain hood, air inlet screen, exhaust damper and mounting hardware. Used to relieve internal air pressure through the unit during economizer operation.
- **PROPANE CONVERSION KIT** - Contains new orifices and gas valve springs to convert from natural to L.P. gas.
- **-60 °F GAS HEAT KIT** - Provides an electric heat kit for the gas compartment for use in extreme low ambient conditions.
- **ECONOMIZER** (Downflow and Horizontal flow)
- **POWER EXHAUST** - (Unit mount - Downflow, Duct mount - Horizontal flow)
- **DUAL ENTHALPY KIT** - Provides a second input to economizer to monitor return air.



Subject to change without notice. Printed in U.S.A.  
Copyright © 2005 by Unitary Products. All rights reserved.

036-21491-004-A-0405  
Supersedes: 036-21491-003-A-1204

---

**Unitary  
Products  
Group**

**5005  
York  
Drive**

**Norman  
OK  
73069**