



Heating and Air Conditioning

TECHNICAL GUIDE

SPLIT-SYSTEM AIR COOLED CONDENSING UNITS

MODELS: HA120

10 NOMINAL TONS

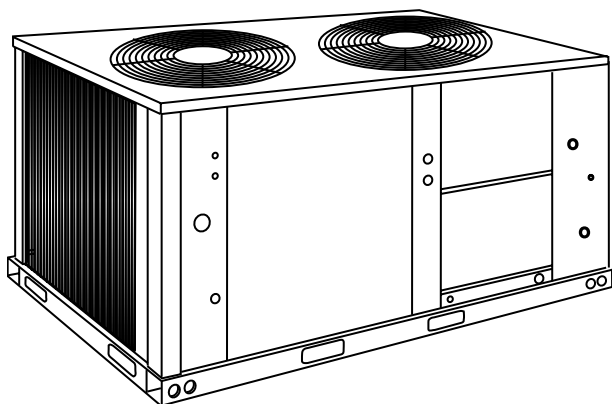

DESCRIPTION

These outdoor condensing units are completely assembled, piped and wired at the factory to provide one-piece shipment and rigging. Each unit is pressurized with a holding charge of refrigerant-22 for storage and/or shipping.

The compact design, clean styling, and quiet operation make these condensing units suitable for almost any outdoor location. On rooftops . . . because they weigh much less than a single package unit of similar capacity and are much easier to rig and support. At ground level. . . because their ample sub-cooling capacity allows them to be located 18 meters (60 feet) below the evaporator coil.

All sheet metal parts are constructed of commercial grade (G90) galvanized steel. Before painting, each part is thoroughly cleaned to remove any grease or dirt from its surfaces. The external parts are then coated with a powder paint to assure a quality finish for many years. This coating system has passed the 750 hour, salt spray test per ASTM Standard B117.

All models include a 1-year limited warranty on the complete unit. The compressor carries an additional 4-year warranty.

A matching line of Evaporator Blower units is also offered to meet your precise capacity and air handling requirements.

FEATURES

- Condenser coil constructed of rifled copper tubes and louvered aluminum fins for durability and long lasting efficient operation.
- Permanently attached base rails with fork lift slots and lifting holes. This design allows for 3-way fork lift access and overhead rigging.
- Both high and low pressure controls.
- Solid state motor protection to prevent the compressor from operating at an unsafe condition.
- Ball bearing condenser fan motors with 1/2 inch shafts.
- Color-coded power and control wiring for easier service and troubleshooting.
- Anti-short cycle timer to protect the compressor.
- A lockout circuit to prevent the unit from cycling on safety control.
- A 24-volt temperature control circuit.
- Standard unit low ambient operation to (35°F).
- A filter-drier (shipped in the unit's compressor compartment for field installation near the evaporator coil).
- Service valves with a back-seating access port for pressure testing the system. Copper stub-outs are factory mounted on the suction and liquid service valves to simplify the field piping connections.
- Exterior access to service pressure port connections.
- Packaging suitable for outdoor storage.
- An optional Phenolic coating is available where the condenser coils are fully dipped in a phenolic coating process to provide longer life in corrosive conditions.



TABLE OF CONTENTS

<p>DESCRIPTION 1</p> <p>FEATURES 1</p> <p>FIELD-INSTALLED ACCESSORIES 4</p> <p>OPERATION 7</p> <p style="padding-left: 20px;">UNIT OPERATION 7</p> <p>GUIDE SPECIFICATION - HA120 9</p> <p>GENERAL 9</p> <p style="padding-left: 20px;">UNIT CABINET 9</p> <p style="padding-left: 20px;">COMPRESSOR 9</p> <p style="padding-left: 20px;">CONDENSER AND FANS 9</p> <p style="padding-left: 20px;">REFRIGERATION COMPONENTS 9</p> <p style="padding-left: 20px;">CONTROLS 9</p> <p style="padding-left: 20px;">ELECTRICAL 9</p> <p style="padding-left: 20px;">ACCESSORIES AND OPTIONS 10</p>	<p style="text-align: center;">LIST OF FIGURES</p> <table style="width: 100%; border-collapse: collapse;"> <thead> <tr> <th style="text-align: left; width: 5%;"><u>Fig. #</u></th> <th style="width: 90%;"></th> <th style="text-align: right; width: 5%;"><u>Pg. #</u></th> </tr> </thead> <tbody> <tr> <td>1</td> <td>UNIT DIMENSIONS & CLEARANCES AND CENTER OF GRAVITY</td> <td style="text-align: right;">4</td> </tr> <tr> <td>2</td> <td>FIELD WIRING - HA120/LA120</td> <td style="text-align: right;">7</td> </tr> </tbody> </table> <p style="text-align: center;">LIST OF TABLES</p> <table style="width: 100%; border-collapse: collapse;"> <thead> <tr> <th style="text-align: left; width: 5%;"><u>Tbl. #</u></th> <th style="width: 90%;"></th> <th style="text-align: right; width: 5%;"><u>Pg. #</u></th> </tr> </thead> <tbody> <tr> <td>1</td> <td>ARI RATINGS</td> <td style="text-align: right;">3</td> </tr> <tr> <td>2</td> <td>UNIT APPLICATION DATA</td> <td style="text-align: right;">3</td> </tr> <tr> <td>3</td> <td>PHYSICAL DATA</td> <td style="text-align: right;">3</td> </tr> <tr> <td>4</td> <td>ELECTRICAL DATA</td> <td style="text-align: right;">4</td> </tr> <tr> <td>5</td> <td>SYSTEM GROSS COOLING CAPACITIES AND POWER REQUIREMENTS - HA120 WITH LA120</td> <td style="text-align: right;">5</td> </tr> <tr> <td>6</td> <td>CONDENSING UNIT ONLY COOLING CAPACITIES AND POWER REQUIREMENTS</td> <td style="text-align: right;">7</td> </tr> <tr> <td>7</td> <td>SUCTION LINE DATA</td> <td style="text-align: right;">8</td> </tr> <tr> <td>8</td> <td>LIQUID LINE DATA</td> <td style="text-align: right;">8</td> </tr> <tr> <td>9</td> <td>REFRIGERANT-22 LINE CHARGE</td> <td style="text-align: right;">8</td> </tr> </tbody> </table>	<u>Fig. #</u>		<u>Pg. #</u>	1	UNIT DIMENSIONS & CLEARANCES AND CENTER OF GRAVITY	4	2	FIELD WIRING - HA120/LA120	7	<u>Tbl. #</u>		<u>Pg. #</u>	1	ARI RATINGS	3	2	UNIT APPLICATION DATA	3	3	PHYSICAL DATA	3	4	ELECTRICAL DATA	4	5	SYSTEM GROSS COOLING CAPACITIES AND POWER REQUIREMENTS - HA120 WITH LA120	5	6	CONDENSING UNIT ONLY COOLING CAPACITIES AND POWER REQUIREMENTS	7	7	SUCTION LINE DATA	8	8	LIQUID LINE DATA	8	9	REFRIGERANT-22 LINE CHARGE	8
<u>Fig. #</u>		<u>Pg. #</u>																																						
1	UNIT DIMENSIONS & CLEARANCES AND CENTER OF GRAVITY	4																																						
2	FIELD WIRING - HA120/LA120	7																																						
<u>Tbl. #</u>		<u>Pg. #</u>																																						
1	ARI RATINGS	3																																						
2	UNIT APPLICATION DATA	3																																						
3	PHYSICAL DATA	3																																						
4	ELECTRICAL DATA	4																																						
5	SYSTEM GROSS COOLING CAPACITIES AND POWER REQUIREMENTS - HA120 WITH LA120	5																																						
6	CONDENSING UNIT ONLY COOLING CAPACITIES AND POWER REQUIREMENTS	7																																						
7	SUCTION LINE DATA	8																																						
8	LIQUID LINE DATA	8																																						
9	REFRIGERANT-22 LINE CHARGE	8																																						

TABLE 1: ARI RATINGS¹

CONDENSING UNIT MODEL	INDOOR BLOWER UNIT MODEL	SYSTEM MBH	SYSTEM EER	CONDENSING UNIT SOUND LEVEL ² (DB)
HA120	LA120	126 ³	10.53	88.0

¹ Certified in accordance with Unitary Large Equipment certification program, which is based on ARI Standard 340/360.

² Rated in accordance with ARI Standard 270.

³ Deduct 1.0 MBH for units operating at 208 volts.

TABLE 2: UNIT APPLICATION DATA

Voltage Variation ¹ Min. / Max.	208/230-3-60	187 / 252
	460-3-60	432 / 504
	575-3-60	540 / 630
Ambient Air on Condenser Coil Min. / Max.	35 °F ² / 125 °F	
Ambient Air on Condenser Coil Min. / Max. with Head Pressure Control	0 - 125 °F	



¹ Utilization range "A" in accordance with ARI Standard 110.

² The minimum allowed ambient temperature for mechanical cooling without the head pressure control accessory installed must be raised if the indoor air flow is less than the minimum value given in the capacity tables.

TABLE 3: PHYSICAL DATA

Model Size (Mbh)	Compressor ¹		Condenser										Unit Weight (Lbs.)		Charge, (Refrigerant-22) Lbs.,-Oz.	
			24" Fan (Propeller)				Fan Motor ²				Coil					
	Rating (Tons)	Cap. (Stg's)	Qty.	Blades/Pitch (Deg.)	Nom CFM	Pitch (Deg.)	Qty.	HP	RPM	Rotation**	Fins per inch	Rows Deep	Ship.	Oper.	Holding ³	Oper. ⁴
HA120	10	1	2	3/26	8100	26	2	3/4	1110	CW	20	2	731	741	2 - 0	27.85

¹ Compressor set consists of two Copeland scroll compressors manifolded into a single refrigerant circuit.

² The ball bearing, 48 frame, single phase condenser fan motor have internal protection are directly connected to the condenser fans.

³ Holding charge is the amount in the unit as shipped from the factory.

⁴ Operating refrigerant charge is for the condensing unit and the matching York air handler, but does not include the charge in the interconnecting piping.

See the Refrigerant Line Charge Table to determine the additional refrigerant charge required for interconnecting piping.

** When viewing the shaft end of the motor.

TABLE 4: ELECTRICAL DATA

Model	Unit Power Supply	Compressor			Condenser Fan Motor			Unit		
		Qty	RLA	LRA	Qty	HP	FLA	Minimum Circuit Ampacity (Amps)	Maximum Fuse Size ¹ (Amps)	Minimum Disconnect Size ² (Amps)
HA120	208/230/3/60	1	42	239.0	2	3/4	3.0	58.8	100	100
	460/3/60	1	19.2	125.0	2	3/4	1.6	27.2	45	45
	575/3/60	1	13.8	80.0	2	3/4	1.4	20.1	30	30

¹ Dual element, time delay type.

² Refer to NEC/NFPA No. 70, Articles 440-11, 12 for information on minimum disconnect sizing.

FIELD-INSTALLED ACCESSORIES

- 0° F LOW AMBIENT - A single phase condenser fan motor and head pressure control to reduce its speed

maintain stable system operation at ambient temperatures down to 0° F.

- Coil Guard - A decorative coil guard provides an additional level of protection for the condenser coils.

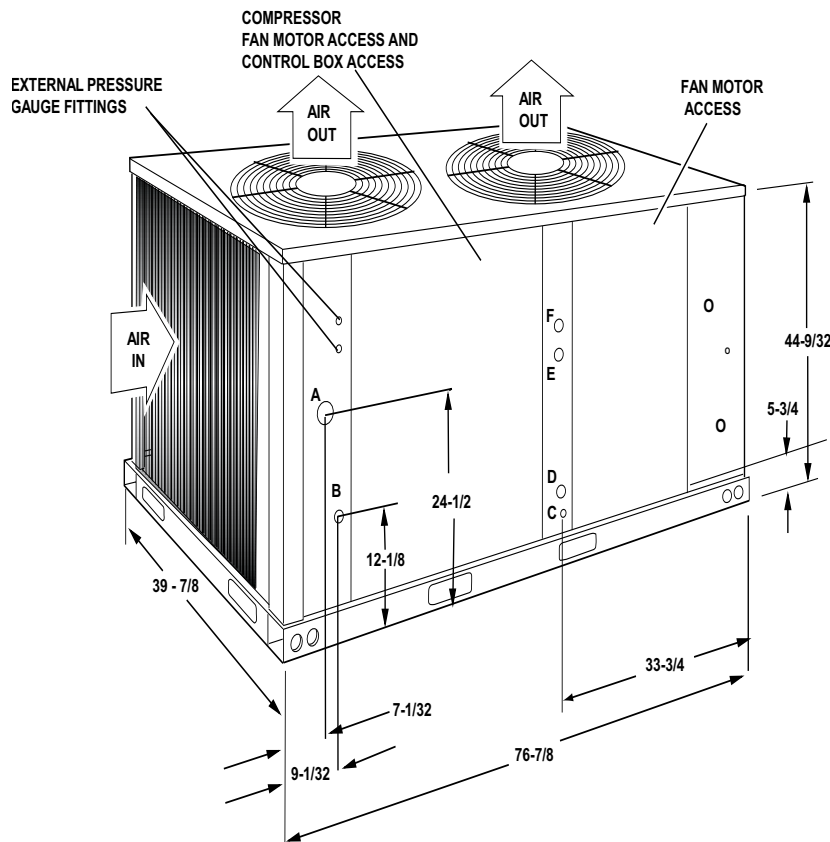

All dimensions are in inches. They are subject to change without notice. Certified dimensions will be provided upon request.

Connection Entry	Connection Size	
		10 Ton
Suction Line	A	1-3/8 OD
Liquid Line	B	5/8 ID
Control Wiring	C	7/8 KO
Power Wiring	D	1-3/4 KO
Accessory Wiring	E	7/8 KO
Accessory Wiring	F	1-3/8 KO

CLEARANCES

Overhead (Top) ¹	120"
Front (Piping and Access Panels)	30"
Left Side	24"
Right Side	24"
Rear	24"
Bottom ²	0"

¹ Units must be installed outdoors. Overhanging structures or shrubs should not obstruct condenser air discharge.

² Adequate snow clearance must be provided if winter operation is expected

FIGURE 1 - UNIT DIMENSIONS & CLEARANCES AND CENTER OF GRAVITY

TABLE 5: SYSTEM GROSS COOLING CAPACITIES AND POWER REQUIREMENTS, HA120 WITH LA120

AIR ON EVAPORATOR COIL		TEMPERATURE OF AIR ON CONDENSER COIL																	
		85°F								95°F									
		TOTAL CAP. ¹ (MBH)	TOTAL INPUT ² (kW)	SENSIBLE CAPACITY (MBH)						TOTAL CAP. ¹ (MBH)	TOTAL INPUT ² (kW)	SENSIBLE CAPACITY (MBH)							
				RETURN DRY BULB (°F)								RETURN DRY BULB (°F)							
CFM	WB (°F)	86	83	80	77	74	71	68	86	83	80	77	74	71	68				
3200	72	140	9.0	83	74	65	56	47	-	-	141	10.8	90	80	71	62	53	-	-
	67	129	8.8	102	93	84	75	66	57	48	124	10.6	100	91	82	73	64	55	46
	62	118	8.6	118	109	100	91	82	73	63	117	10.5	117	117	110	101	92	83	74
	57	117	8.6	117	117	107	98	89	80	71	118	10.5	118	118	116	107	98	89	80
3600	72	143	9.4	90	79	69	59	48	-	-	141	10.8	92	82	71	61	50	-	-
	67	132	9.2	110	100	89	79	68	58	48	124	10.6	103	92	82	72	61	51	40
	62	120	9.1	120	116	106	96	85	75	64	117	10.5	117	117	110	100	89	79	69
	57	119	9.1	119	119	114	104	93	83	72	118	10.5	118	118	116	106	96	85	75
4000	72	146	9.9	96	85	73	61	50	-	-	141	10.8	95	83	71	60	48	-	-
	67	135	9.7	118	106	94	83	71	59	48	128	10.7	114	102	91	79	67	56	44
	62	123	9.5	123	123	112	101	89	77	66	117	10.5	117	117	110	98	87	75	63
	57	122	9.5	122	122	121	109	97	86	74	118	10.5	118	118	116	105	93	81	70
4400	72	149	10.0	102	89	76	63	50	-	-	147	10.9	105	92	79	66	53	-	-
	67	137	9.7	125	112	99	86	73	60	47	129	10.7	117	104	91	78	65	52	39
	62	126	9.6	126	126	117	104	91	78	65	122	10.5	122	122	119	106	93	80	67
	57	124	9.6	124	124	124	111	98	85	72	123	10.6	123	123	122	109	96	83	70
4800	72	152	10.0	108	94	80	65	51	-	-	153	11.0	116	102	87	73	59	-	-
	67	140	9.8	132	117	103	89	74	60	46	134	10.7	129	115	101	86	72	58	43
	62	128	9.6	128	128	122	108	94	79	65	127	10.6	127	127	127	113	99	84	70
	57	127	9.6	127	127	127	113	98	84	70	128	10.7	128	128	128	114	100	85	71

AIR ON EVAPORATOR COIL		TEMPERATURE OF AIR ON CONDENSER COIL																	
		105°F								115°F									
		TOTAL CAP. ¹ (MBH)	TOTAL INPUT ² (kW)	SENSIBLE CAPACITY (MBH)						TOTAL CAP. ¹ (MBH)	TOTAL INPUT ² (kW)	SENSIBLE CAPACITY (MBH)							
				RETURN DRY BULB (°F)								RETURN DRY BULB (°F)							
CFM	WB (°F)	86	83	80	77	74	71	68	86	83	80	77	74	71	68				
3200	72	133	11.9	84	75	66	57	47	-	-	125	13.0	78	69	60	51	42	-	-
	67	119	11.7	98	89	80	71	62	53	43	115	12.8	96	87	78	69	60	51	41
	62	111	11.5	111	110	102	93	84	75	66	105	12.5	105	103	94	85	76	67	57
	57	113	11.6	113	112	106	97	88	79	70	107	12.6	107	105	96	87	78	69	60
3600	72	134	11.9	88	78	67	57	47	-	-	127	13.0	84	74	64	53	43	-	-
	67	120	11.7	103	93	82	72	62	51	41	116	12.8	103	93	83	72	62	51	41
	62	112	11.5	112	111	105	94	84	74	63	106	12.5	106	105	100	89	79	68	58
	57	113	11.6	113	113	109	99	88	78	68	108	12.6	108	108	102	92	81	71	60
4000	72	135	12.0	93	81	69	58	46	-	-	129	13.1	91	79	67	56	44	-	-
	67	121	11.7	108	96	85	73	61	50	38	118	12.8	111	99	87	76	64	52	41
	62	113	11.5	113	113	108	96	84	73	61	108	12.6	108	108	105	94	82	70	59
	57	114	11.6	114	114	112	100	89	77	65	110	12.7	110	110	108	96	84	73	61
4400	72	139	12.0	101	88	75	62	49	-	-	131	13.1	97	84	71	58	41	-	-
	67	125	11.8	117	104	91	78	65	53	40	120	12.9	117	105	92	79	66	53	40
	62	116	11.6	116	116	114	101	88	75	62	110	12.6	110	110	109	96	83	70	57
	57	118	11.7	118	118	117	104	91	78	65	112	12.7	112	112	111	98	85	72	59
4800	72	143	12.1	109	95	81	66	52	-	-	134	13.2	103	88	74	60	45	-	-
	67	129	11.8	126	113	98	84	70	55	41	123	12.9	123	110	96	82	67	53	39
	62	120	11.6	120	120	120	105	91	77	62	112	12.7	112	112	112	98	83	69	55
	57	121	11.7	121	121	121	107	93	78	64	114	12.7	114	114	114	100	86	71	57

TABLE 5: SYSTEM GROSS COOLING CAPACITIES AND POWER REQUIREMENTS, HF-10 WITH LF-10 (CONT.)

AIR ON EVAPORATOR COIL		TEMPERATURE OF AIR ON CONDENSER COIL									
		125°F									
		TOTAL CAP. ¹ (MBH)	TOTAL INPUT ² (kW)	SENSIBLE CAPACITY (MBH)							
				RETURN DRY BULB (°F)							
CFM	WB (°F)			86	83	80	77	74	71	68	
3200	72	118	14.1	73	64	54	45	36	-	-	
	67	110	13.8	94	85	76	67	58	48	39	
	62	99	13.5	99	96	86	77	68	58	49	
	57	101	13.6	101	99	86	77	68	59	49	
3600	72	120	14.2	81	70	60	49	39	-	-	
	67	113	13.9	104	93	83	72	62	52	41	
	62	101	13.6	101	99	94	84	73	63	53	
	57	103	13.7	103	102	95	84	74	64	53	
4000	72	123	14.2	89	77	65	54	42	-	-	
	67	115	14.0	113	102	90	78	67	55	43	
	62	103	13.6	103	103	103	91	79	68	56	
	57	106	13.7	106	106	103	92	80	68	57	
4400	72	124	14.3	92	79	66	53	40	-	-	
	67	116	14.0	116	105	92	79	66	53	40	
	62	104	13.7	104	104	104	91	78	65	52	
	57	106	13.7	106	106	105	92	79	66	53	
4800	72	125	14.3	96	81	67	53	39	-	-	
	67	117	14.0	117	108	94	79	65	51	36	
	62	105	13.7	105	105	105	90	76	62	47	
	57	107	13.8	107	107	107	93	79	64	50	

Nominal Rating

1 - These capacities are gross ratings. For net capacity, deduct air blower motor, MBh = 3.415 x kW. Refer to the appropriate Blower Performance Table for the kW of the supply air blower motor.

2 - These ratings include the condenser fan motors (total 1 kW) and the compressor motors but not the supply air blower motor.

TABLE 6: CONDENSING UNIT ONLY COOLING CAPACITIES AND POWER REQUIREMENTS

Model	Suction Press & Saturation Temp		Temperature of Air on Condenser Coil, °F											
			65		75		85		95		105		115	
	PSIG	°F	MBH	KW	MBH	KW	MBH	KW	MBH	KW	MBH	KW	MBH	KW
HA120	61.6	35	128	7.9	122	8.5	116	9.2	110	10	104	11.1	97	12.2
	68.5	40	139	8	133	8.7	127	9.4	120	10.3	114	11.3	107	12.3
	76	45	151	8.3	144	8.9	138	9.6	131	10.5	124	11.4	117	12.5
	84	50	163	8.5	156	9.1	149	9.9	142	10.7	134	11.7	127	12.7

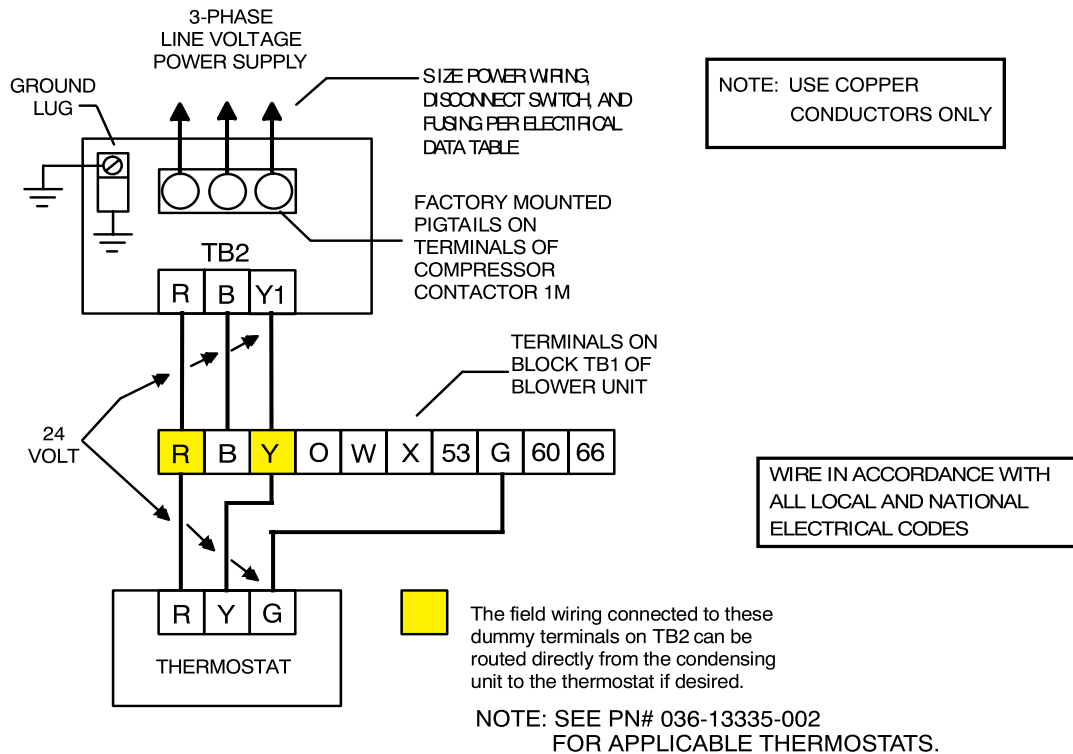

FIGURE 2 - FIELD WIRING - HA120/LA120

OPERATION

UNIT OPERATION

When the external control calls for cooling at terminal:

1. The system controller (SC) is energized. The system controller starts the compressor and enables the condenser fans by energizing contactor 1M (and 2M on the 208/230 volt models).

Condenser fan motor #1 is energized with the compressor. Fan motor #2 operation is controlled through the Pressure Switch (PS) which will de-energize the motor when the discharge pressure falls below 180 PSI.

2. Safety Lockout: The system controller (SC) has a lockout circuit to prevent compressor short-cycling on a safety control with automatic reset. If the high or low refrigerant pressure switches (HP or LP) open, the SC will enter lockout mode.

SC provides a 90 second bypass of the low pressure switch LP to prevent nuisance lockouts during unit start-up.

A malfunction light (24V, 2 A max. resistive load) can be energized through SC, by connecting the light between terminals X and B on TB1. Terminal X will energize when SC locks out.

- Unit is equipped with an anti-short cycle timer to prevent two successive compressor starts within 5 minutes. If the compressor fails to start with a call for cooling and SC is not locked out, wait at least 6 minutes for the anti-cycle timer to reset.

NOTE: To reset the unit after a lockout:

- Turn the system switch on the thermostat to the "OFF" position and back to the "COOL" position.

OR

- Increase the set point of the room thermostat above the temperature in the conditioned space and return it to its original setting.

If the unit continues to be shut down by one of its safety controls, service should be called to determine the cause of the problem. Repeatedly resetting the lockout circuit may damage the unit.

TABLE 7: SUCTION LINE DATA^{1,2}

Model Designation	Nominal Capacity (Tons)	Refrigerant Flow Rate ³ (Lbs./Min.)	Type L Copper tubing (Inches O.D.)	Refrigerant Gas Velocity (FT./Min.)	Friction Loss ^{4,5} (PSI/100 Ft.)
HA120	10	30	1-3/8	2280	2.8

¹ All horizontal suction lines should be pitched at least 1 inch every 20 feet in the direction of the refrigerant flow to aid the return of oil to the compressor.

² Every vertical suction riser greater than 25 feet in height should have a "P" trap at the bottom to facilitate the return of oil to the compressor. Use short radius fittings for these traps.

³ Based on Refrigerant-22 at the nominal capacity of the condensing unit, a suction temperature of 40° F and a liquid temperature of 105° F.

⁴ Although suction lines should be sized for a friction loss equivalent to a 2° F change in saturation temperature (or approximately 3 psi), sizing the lines for the proper return of oil is more important.

⁵ These friction losses do not include any allowances for valves or fittings.

TABLE 8: LIQUID LINE DATA

Model	Nominal Capacity Tons	Refrigerant Flow Rate ¹ (Lbs./Min.)	Type L Copper Tubing (Inches O.D.)	Pressure Drop ²	
				Friction ³ (PSI/100 Ft.)	Vertical Rise (PSI/Ft.)
HA120	10	30	5/8	5.8	0.5

¹ Based on Refrigerant-22 at the nominal capacity of the condensing unit, a liquid temperature of 105° F and a suction temperature of 40° F.

² These friction losses do not include any allowances for a strainer, filter-drier, solenoid valve, isolation valve or fittings.

³ The total pressure drop of the liquid line for both friction and vertical rise must not exceed 40 PSI. If the pressure drop exceeds 40 PSI, the liquid refrigerant could flash before it reaches the expansion valve. This flashing will not only cause erratic valve operation and poor system performance, but could also damage the expansion valve.

TABLE 9: REFRIGERANT-22 LINE CHARGE¹

Liquid Line ² Inches, O.D.	5/8	0.113 lb./ft.
Suction Line ² Inches, O.D.	1-3/8	0.013 lb./ft.

NOTE: Add the operating charge of the condensing unit, the evaporator coil and the refrigerant lines to determine the total refrigerant charge of the system.

¹ Charges are based on 40° F suction temperature and a 105° F liquid temperature.

² Type "L" copper tubing.

GUIDE SPECIFICATION - HA120

GENERAL

- A. Units shall be manufactured in a facility registered under the ISO 9002 manufacturing quality standard.
- B. Units shall be UL listed to US and Canadian safety standards.
- C. Unit shall be packaged to allow outdoor storage.
- D. Warranty shall be a full year limited parts warranty on the complete unit with an additional 4-year warranty on the compressor.
- E. Unit shall be rated in accordance with ARI 360.

Unit Cabinet

- A. Cabinet shall be constructed of 18 gauge, zinc-coated steel, finished with a powder paint process capable of withstanding a minimum of 750 salt spray hours according to ASTM B117.
- B. Cabinet screws shall comply with the ASTM B117 salt spray test for a minimum of 750 hours.
- C. Panels shall be removable for easy access to all internal components during maintenance and service.
- D. Cabinet shall feature a separate access panel for the controls so that unit airflow need not be disturbed during servicing.
- E. Permanently attached base rails shall have 3-way fork lift access and lifting holes for ease of installation.

Compressor

- A. Compressor shall be hermetic scroll.
- B. Compressor shall feature motor overload protection.
- C. A crankcase heater shall keep refrigerant from diluting the compressor oil in the sump. Crankcase heater shall be field replaceable without removal of the charge.
- D. Neoprene isolators shall be used to minimize the transmission of sound and vibration.

Condenser and Fans

- A. Fan motors shall be direct-drive with propeller-type condenser fans which discharge air vertically upward.
- B. Fan motors shall have permanently lubricated ball-bearings for longer wear during start and stop cycles and shall have inherent overload protection.

- C. Coil shall be constructed of rifled copper tubing mechanically expanded and bonded to louvered aluminum fins. Coil shall include an integral subcooler.

Refrigeration Components - Refrigeration system shall contain the following:

- High and low pressure cut-outs
- Suction and liquid line service valves to ease installation and recovery of refrigerant
- External ports to accommodate gauge lines, allowing for easy servicing
- Filter drier shipped in unit for field installation
- Holding charge of R-22

Controls - Unit controls shall include:

- A. 24 volt control circuit with terminal blocks.
- B. Color-coded wiring for easy service and troubleshooting.
- C. Independent line break thermal protection for the condenser fans.
- D. 5 minute anti-short cycle timer to protect the compressor from frequent cycling.
- E. Unit safety lockouts which automatically reset from the thermostat once the anti-short cycle timer is satisfied. Safety lockouts will also generate a 24 volt signal to the "X" terminal, allowing notification to the user via the thermostat fault light (if present). These safety lockouts shall include:
 1. High refrigerant pressure
 2. Low refrigerant pressure. Low refrigerant pressure shall be bypassed for the first 120 seconds (approximate) of operation to eliminate nuisance trips.
- F. Compressor motor protection to automatically shut-down the unit in the event of motor overcurrent or low control voltage conditions. Unit shall automatically restart after satisfying the anti-short cycle timer.
- G. Low ambient operation down to 35 °F without a low ambient kit. (Operation down to 0 °F with the optional low ambient kit.)

Electrical

- A. Units shall be _____ volts, 3 phase, with a single power point connection.
- B. Unit control circuit shall have a 24 volt transformer, sized sufficiently to operate the indoor fan.
- C. All condenser fan motors and the secondary of each transformer shall be grounded.

Accessories and Options

A. Head Pressure Control

Shall include a condenser fan motor and a pressure controller, allowing operation of the condensing unit down to 0°F.

B. Coil Guard

Field installed decorative grille shall be placed on the units to provide further coil protection.

C. Phenolic Coating on Condenser Coil

Condenser coils shall be dipped in a four-coat phenolic coating process to provide longer life in corrosive conditions.

Subject to change without notice. Printed in U.S.A.
Copyright © by Unitary Products Group 2004. All rights reserved.

036-21365-003-C-0104
Supersedes: 036-21365-003-B-0703

**Unitary
Products
Group**

**5005
York
Drive**

**Norman
OK
73069**