



CERTIFICATE

By Authority Of
THE UNITED STATES OF AMERICA
Legally Binding Document

By the Authority Vested By Part 5 of the United States Code § 552(a) and Part 1 of the Code of Regulations § 51 the attached document has been duly INCORPORATED BY REFERENCE and shall be considered legally binding upon all citizens and residents of the United States of America. *HEED THIS NOTICE:* Criminal penalties may apply for noncompliance.



Document Name: APSP 16: Standard Suction Fittings for Use in Swimming Pools, Wading Pools, Spas, and Hot Tubs

CFR Section(s): 16 CFR 1450.3

Standards Body: Association of Pool and Spa Professionals



Official Incorporator:

THE EXECUTIVE DIRECTOR
OFFICE OF THE FEDERAL REGISTER
WASHINGTON, D.C.

ANSI/APSP-16 2011



American National Standard for Suction Fittings for Use in Swimming Pools, Wading Pools, Spas, and Hot Tubs

Approved February 17, 2011

Courtesy of Michelle Vlach Photography, www.michellevlach.com



APSP

*The Association of
Pool & Spa Professionals®*

Suction Fittings for Use in Swimming Pools, Wading Pools, Spas, and Hot Tubs Errata, 2011-09-30

Page	Error
4	2.3.1.2 Entrapping Force Criterion for Q equation is shown incorrectly. The correct equation is shown below.
5	3.1.1: The words "conducted by a certification body" have been deleted. Corrected paragraph is shown below.
6	3.1.6: This paragraph was incorrectly divided into two paragraphs. Corrected paragraph is shown below.
7	3.3.1, 3.4, 3.5.2, and 3.6.1: These equations incorrectly omitted "× K." Corrected paragraphs are shown below.
8	3.7.1: The word "vacuum" has been replaced by "differential pressure."
15	Table 1: Incorrect numbers in rows 1 and 10 of this table have been fixed. Corrected rows are shown on back.
18	7.1.1: The lines "Swim Jet" and "Life: 7 Years" were incorrectly shown on the same line. Corrected example is shown on back.
A-2	Table II: In the second row under "Field Fabricated Outlets," the word "Yes" has been corrected to "Per manufacturer." Corrected row is shown on back.

2.3.1.2 Entrapping Force Criterion for Q

$$Q = a_r \sqrt{C \frac{F}{2} a_b}$$

3.1.1 Certification. All testing and any certification of products to this Standard shall be in accordance with ISO/IEC 17025, except for field fabrication suction outlets which shall be certified in accordance with para. 2.3.1.7.

3.1.6 Crack Detection. After each physical test, the unit shall be washed in a standard liquid detergent solution, rinsed with clear water, and dried prior to application of ink as specified in para. 3.1.6.1. After inking, the unit shall be visually inspected in accordance with para. 3.1.6.2. To hasten drying, the surface of the unit shall be permitted to be wiped with a clean chamois leather or a clean absorbent lint-free material for this test only.

3.3.1 Test Method. Using the tup and a 2 in. (51 mm) diameter "Skin Pad" on the face of the tup, and tup speed described in para. 3.3, the six fittings shall be mounted in a horizontal plane and tested. The "Skin Pad" is a ¼ in. (6.35 mm) thick Buna-N rubber pad of Shore A durometer 60 ±5 hardness. The tup and pad shall be centered

- on the fitting face
- at two points midway between the center and edge
- at two points between stiffeners, if any
- at two points furthest from any support post.

A load is applied at each of the above locations until 300 lbf × K ±10 lbf (1 334 N × K ±44 N) is reached.

3.4 Horizontal Load and Deformation Test

Fittings to be tested shall be the six as previously tested in para. 3.3. This test is identical to the Vertical Test except that the load is 150 lbf × K ±5 lbf (667 N × K ±22 N). This applies only to fittings intended for and marked "Wall Only" or "Wall or Floor."

3.5.2 Performance Requirement. Suction fittings shall not sustain loss of any material from the fitting, exclusive of plating or finish upon protrusion, or when a value of 600 lbf × K ±10 lbf (2 669 N × K ±44 N) is reached. Permanent deformation shall not be considered a failure.

3.6.1 Test Method. The fitting shall be tested by the application of a 150 lbf × K ±5 lbf (667 N × K ±22 N) test load applied 30° from the mounting plane by a loading face 2 in.² (645 mm²) covered with a 2 in. × 2 in. (51 mm × 51 mm) "Skin Pad" on its face. The six fittings shall be tested using the point load machine described in para. 3.3. Three fittings shall be tested with fasteners directly in line with the load to test the fastener's strength, and three shall be tested with the load midway between fasteners for general strength.

3.7.1 Test Method

(a) The fitting to be tested shall be mounted on a horizontal surface and covered with a 20 mil (0.5 mm) plastic material or other suitable material. The fitting outlet shall be connected to a vacuum or pressure (pressure will be required for K factors greater than 1.0) system and it shall be subjected to a 28.5 in. (724 mm) Hg × K differential pressure within 60 sec ±5 sec. The vacuum shall be sustained for 5 min ±10 sec.

Bather	Min. Width Blocking Element to Shadow Tested Cover	Blocking Element Length = 1.2777 × Width	Basis is Child Width	Ratio of Element Width to Child Width	Ratio Cubed	Times Child Weight = 30 lb	One-Half Weight	Maximum Removal Effort No.
99th percentile male	18	23.0	9	2.00	8.00	240	120	120
	13.5	17.2	9	1.50	3.38	101	51	51

7.1.1 Fittings that comply with ASME A112.19.8 shall be permanently marked as follows in a manner that is visible in the installed position and where the text is no smaller than 0.08 in. (2.03 mm) tall:

(a) The following is an example of a typical marking:

EXAMPLE:

For Multiple Drain Use Only

108 GPM

Swim Jet

Life: 7 Years

Wall Only

Quantum 1563-W

Type	Field Fabricated Outlets	Venturi Outlets	Swim Jet Combination Outlets	Submerged Suction Outlets	Self-Contained Spa Fittings
Certification	Registered Design Professional	Independent Laboratory (1)	Independent Laboratory (1)	Independent Laboratory (1)	Independent Laboratory (1)
Single or multiple	Per manufacturer	Per manufacturer	Per manufacturer	Per manufacturer	Multiple only

ANSI/APSP-16 2011

**American National Standard for
Suction Fittings for Use in
Swimming Pools, Wading Pools, Spas, and Hot Tubs**

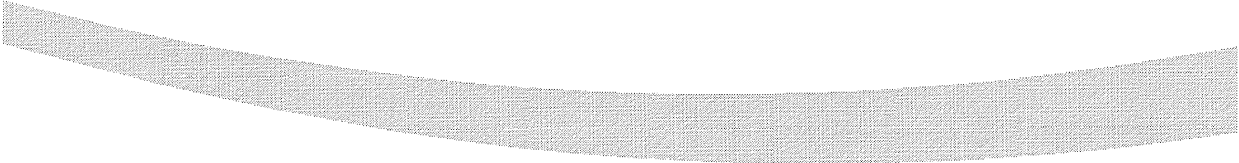

SECRETARIAT:

Association of Pool & Spa Professionals
2111 Eisenhower Avenue
Alexandria, VA 22314
703 838-0083
APSP.org

Approved February 17, 2011
American National Standards Institute

American National Standard

Approval of an American National Standard requires verification by ANSI that the requirements for due process, consensus, and other criteria for approval have been met by the standard developer. Consensus is established when, in the judgment of the ANSI Board of Standards Review, substantial agreement has been reached by directly and materially affected interests. Substantial agreement means much more than a simple majority, but not necessarily unanimity.

Consensus requires that all views and objections be considered and that a concerted effort be made toward their resolution. The use of American National Standards is completely voluntary; their existence does not in any respect preclude anyone, whether he has approved this standard or not, from manufacturing, marketing, purchasing, or using products, processes, or procedures not conforming to the standards.

The American National Standards Institute does not develop standards and will in no circumstances give an interpretation of any American National Standard. Moreover, no person shall have the right or authority to issue an interpretation of an American National Standard in the name of the American National Standards Institute. Requests for interpretations should be addressed to the secretariat or sponsor whose name appears on the title page of this standard.

NOTICE: This American National Standard may be revised or withdrawn at any time. The procedures of the American National Standards Institute require that action be taken periodically to reaffirm, revise, or withdraw this standard.

Important Notice about this Document

This voluntary standard has been developed under the published procedures of the American National Standards Institute (ANSI). The ANSI process brings together volunteers representing varied viewpoints and interests to achieve consensus.

APSP does not write the standards. Rather, APSP facilitates a forum for its members, and others interested in pool and spa design and safety, to develop standards through the consensus procedures of the American National Standards Institute (ANSI). While the APSP administers the process and establishes rules to promote fairness in the development of consensus, it does not independently test, evaluate, or verify the accuracy of any information or the soundness of any judgments contained in its codes and standards.

In issuing and making this document available, the APSP is not undertaking to render professional or other services for or on behalf of any person or entity. Nor is the APSP undertaking to perform any duty owed by any person or entity to someone else. The APSP disclaims liability for any personal injury, property, or other damages of any nature whatsoever, whether special, indirect, consequential, or compensatory, directly or indirectly resulting from the publication of, use of, or reliance on this document.

The APSP has no power, nor does it undertake, to police or enforce compliance with the contents of this document. The APSP does not list, certify, test, or inspect products, designs, or installations for compliance with this document. Any certification or other statement of compliance with the requirements of this document shall not be attributable to the APSP. Any certification of products stating compliance with requirements of this document is the sole responsibility of the certifier or maker of the statement. The APSP, its members, and those participating in its activities do not accept any liability resulting from compliance or noncompliance with the provisions given herein, for any restrictions imposed on materials, or for the accuracy and completeness of the text.

Anyone using this document should rely on his or her own independent judgment or, as appropriate, seek the advice of a competent professional in determining the exercise of reasonable care in any given circumstance. It is assumed and intended that pool users will exercise appropriate personal judgment and responsibility and that public pool owners and operators will create and enforce rules of behavior and warnings appropriate for their facility.

Copyright Notice

Copyright ©2011 by The Association of Pool & Spa Professionals, 2111 Eisenhower Avenue, Alexandria, VA 22314-4695. Printed in the United States of America. All rights reserved. No part of this book may be reproduced, stored in a retrieval system, transcribed or transmitted, in any form or by any means or method, electronic, mechanical, photocopy, recording, or otherwise, without advance written permission from the publisher: The Association of Pool & Spa Professionals, 2111 Eisenhower Avenue, Alexandria, VA 22314-4695.

“APSP,” “The Association of Pool & Spa Professionals,” and the APSP logo are trademarks of The Association of Pool & Spa Professionals.

Cover Photo: Courtesy of Michelle Vlach Photography, www.michellevlach.com

Foreword

This Foreword is not part of the American National Standard ANSI/APSP-16 2011. It is included for information only.

The ANSI/APSP-16 2011, Standard for Suction Fittings for Use in Swimming Pools, Wading Pools, Spas, and Hot Tubs, was approved by ANSI February 17, 2011, as a new standard.

The objective of this voluntary standard is to provide recommended minimum guidelines for testing and marking requirements for suction fittings that are designed for use on totally submerged suction outlets in swimming pools, wading pools, spas, and hot tubs, as well as other aquatic facilities. It is intended to meet the needs for incorporation into national or regional building codes, and also for adoption by federal, state, and/or local governments, and/or as a local code or ordinance. It is understood that for the sake of applicability and enforceability, the style and format of the standard may need adjustment to meet code or ordinance style of the jurisdiction adopting this document.

The APSP does not certify, test or endorse any product.

The recommendations and testing practices in this standard are based upon sound engineering principles, research, and field experience that, when applied properly, contribute to the delivery and installation of a safe product.

The words “safe” and “safety” are not absolutes. While the goals of this standard are to design and construct a safe, enjoyable product, it is recognized that risk factors cannot, as a practical matter, be reduced to zero in any human activity. This standard does not replace the need for good judgment and personal responsibility. In permitting use of the pool or spa by others, owners must consider the skill, attitude, training, and experience of the expected user.

As with any product, the specific recommendations for installation and use provided by the manufacturer should be carefully observed.

This standard was prepared by the APSP-16 Suction Fittings Standard Writing Committee of the Association of Pool and Spa Professionals (APSP) in accordance with American National Standards Institute (ANSI) Essential Requirements: Due process requirements for American National Standards.

Consensus approval was achieved by a ballot of the balanced APSP Standards Consensus Committee below and through an ANSI Public Review process. The ANSI Public Review provided an opportunity for additional input from industry, academia, regulatory agencies, safety experts, state code and health officials, and the public at large.

Suggestions for improvement of this standard should be sent to the Association of Pool and Spa Professionals, 2111 Eisenhower Avenue, Alexandria, VA 22314.

Organizations Represented

Consensus approval in accordance with ANSI procedures was achieved by ballot of the following APSP Standards Consensus Committee. Inclusion in this list does not necessarily imply that the organization concurred with the submittal of the proposed standard to ANSI.

Producers

All American Custom Pools & Spas, Inc.	John Romano
Custom Pools, Inc.	Scott Heusser
Gary Pools, Inc.	Leif Zars
Hayward Industries	John O'Hare
HornerXpress South Florida	Bill Kent
Master Spas Inc.	Nathan Coelho
Rosebrook Carefree Pools, Inc.	John Bently
Royal Fiberglass Pools Inc.	Tony Hebert
S.R. Smith, LLC	Bill Svendsen
Van Kirk & Sons, Inc.	Don Cesarone

General Interest

American Red Cross	Connie Harvey
Con-Serv Associates, Inc.	Wally James
Conroe Independent School District, TX	Louis Sam Fruia
Higgins Environmental Solutions (NEHA)	Florence Higgins
Walt Disney Parks and Resorts	Michael Beatty
Gene Wells Consulting	Gene Wells
Don Witte, Consultant	Don Witte
World Waterpark Association	Rick Root
Wyndham Worldwide Corporation (American Hotel & Lodging Association).	Tony Mendez
YMCA of the USA.	Albert Tursi

Government/User

City of Southfield, MI	Wayne Jewell
City of Mount Dora, FL	Tom Allen
Fairfax County, VA	Marc Mordue
Indiana Building Safety and Codes.	Don LeBrun
Madison County Inspection Dept., WI	Matthew Danner
N.J. Dept. of Community Affairs Division of Codes and Standards	Thomas Pitcherello
Oregon Public Health Division	Stephen Keifer
Wisconsin Dept. of Commerce Safety and Buildings Division.	Lynita Docken
Texas Dept. of State Health Services	Kathleen Moore
U.S. Consumer Product Safety Commission	Troy Whitfield*
Washington State Dept. of Health	Gary Fraser

*non-voting

In accordance with American National Standards Institute (ANSI) procedures, this document will be reviewed periodically. The Association of Pool & Spa Professionals welcomes your comments and suggestions, and continues to review all APSP standards, which include:

- ANSI/APSP-1 2003 Standard for Public Swimming Pools
- ANSI/APSP-2 1999 Standard for Public Spas
- ANSI/APSP-3 1999 Standard for Permanently Installed Residential Spas
- ANSI/APSP-4 1999 Standard for Aboveground/Onground Residential Swimming Pools
- ANSI/APSP-5 2011 Standard for Residential Inground Swimming Pools
- ANSI/APSP-6 1999 Standard for Residential Portable Spas
- ANSI/APSP-7 2006 Standard for Suction Entrapment Avoidance in Swimming Pools, Wading Pools, Spas, Hot Tubs, and Catch Basins
- ANSI/APSP-8 1996 Model Barrier Code for Residential Swimming Pools, Spas and Hot Tubs
- ANSI/APSP-9 2005 Standard for Aquatic Recreation Facilities
- ANSI/APSP-11 2009 Standard for Water Quality in Public Pools and Spas
- ANSI/APSP-14 2011 Standard for Portable Electric Spa Energy Efficiency
- APSP-15 Standard for Pool and Spa Energy Efficiency (Draft)
- ANSI/APSP -16 2011 Suction Fittings for Use in Swimming Pools, Wading Pools, Spas, and Hot Tubs
- APSP-17 Manufactured Safety Vacuum Release Systems (SVRS) for Residential and Commercial Swimming Pool, Spa, Hot Tub, and Wading Pool Suction Systems (Draft)
- APSP 2005 Workmanship Standards for Swimming Pools and Spas

APSP-16 Writing Committee

Gary Pools, Inc.	Leif Zars, Chair
NSF International	Sal Aridi, Vice Chair
Aquatic Development Group	Jim Dunn
Balboa Water Group, Inc.	Paul Rosenau
Hayward Pool Products	Robert Rung
IAPMO.	Maribel Campos
Paramount Pool and Spa Systems	Dominic Conn
Pentair Water Pool and Spa	Steve Barnes
Stingl Products LLC	David Stingl
Texas Dept. of State Health Services	Kathleen O. Moore
Underwriters Laboratories Inc.	Gary Siggins
U.S. Consumer Product Safety Commission	Troy Whitfield*
Vac-Alert Industries, LLC	George Pellington
Walt Disney Parks and Resorts.	Andrea M. Crabb
Water Technology, Inc.	Brian W. Freber
Waterway Plastics Inc	Ray Mirzaei

* non-voting

APSP Staff

Bernice Crenshaw, Director, Standards and Technical Information
Carvin DiGiovanni, Senior Director, Technical and Standards

Contents

Sections	Page
1 General	1
2 Fitting Design, Assembly, and Material Requirements	3
3 Physical Testing	5
4 Hair Entrapment	8
5 Body Entrapment	13
6 Finger and Limb Entrapment	15
7 Packaging and Installation Instructions	18

Figures

1 Finger Probe “Edge”	2
2 Field Built Sump	5
3 Test Tank Pull Mechanism	9
4 Test Tank Side View	9
5 Test Tank Top View	9
6 Test Tank Mounting Plate	10
7 Test Tank Baffles	10
8 Anticlastic Mounting Surface (Typical)	11
9 Hair Test Configuration for Self-Contained Spa Fittings	12
10 Hair Test Diagrams	13
11 Body Block Element	14
12 Body Block Element Dimensions	14
13 Finger Probe–Finger and Limb Entrapment Test	16
14 Finger Probe	16
15 Finger Probe Dimensions	17
16 Finger Probe Knuckle Dimensions	17

Tables

1 Applicable Body Block Element Calculation of Removal Force	15
---	----

Mandatory Appendices

I Torso Specimen With Rectangle Superimposed	A-1
II Fitting Type Requirements	A-2

Non-mandatory Appendix

A Suction Fitting Test Form–Hair Entrapment	A-3
---	-----

Suction Fittings For Use In Swimming Pools, Wading Pools, Spas, And Hot Tubs

1 General

1.1 Scope

1.1.1 General Requirements. This Standard establishes materials, testing, and marking requirements for suction fittings that are designed to be totally submerged for use in swimming pools, wading pools, spas, and hot tubs, as well as other aquatic facilities.

1.1.2 Definition. Suction fittings shall be defined as all components, including the sump and/or body, cover/grate, and hardware.

1.1.3 Compliance. Demonstration of compliance for this Standard is merely an indication that the product meets performance requirements and specifications contained in this Standard.

1.1.4 Revisions. The provisions of this Standard shall not be construed to prevent the use of any alternate material or method of construction provided any such alternate meets the full intent of the standard.

1.1.5 Exclusions

1.1.5.1 Skimmers shall be excluded from evaluation to this Standard.

1.1.5.2 Vacuum connection covers shall be excluded from evaluation to this Standard.

1.1.6 Types of Suction Fittings

1.1.6.1 General. A manufacturer or designer of any suction outlet cover/grate shall indicate under which Type the cover/grate is listed.

1.1.6.2 Field Fabricated Outlets. All non-manufactured suction outlets constructed in the field with individual components shall be considered as "Field Fabricated Outlets."

1.1.6.3 Venturi Outlets. All venturi activated indirect-suction outlets or venturi activated debris collection systems shall be considered as "Venturi Outlets."

1.1.6.4 Swim Jet Combination Fittings. All swim jet combination fittings that combine suction and discharge into one housing, creating a high velocity, high volume stream of water to swim, jog, or walk against, as well as massage, shall be considered "Swim Jet Combination Fittings."

1.1.6.5 Submerged Suction Outlets. All other suction outlets for use in swimming pools, wading pools, spas, and hot tubs, as well as all other aquatic facilities, shall be considered as "Submerged Suction Outlets."

1.1.6.6 Self-Contained Spa Fittings. Suction outlet fittings used exclusively in self-contained factory manufactured spas shall be considered "Self-Contained Spa Fittings."

1.1.7 Single or Multiple Usage

1.1.7.1 Cover/grates that pass the body entrapment portion of this Standard as well as meeting all other requirements in this Standard shall be permanently marked "For Single or Multiple Outlet Use," "For Single Outlet Use," or "For Multiple Outlet Use Only" at the manufacturer's option.

1.1.7.2 Cover/grates that fail the body entrapment portion of this Standard or any other requirements of this Standard may not be certified under this Standard.

1.2 Related Standards

Since the scope of this Standard is directly related to suction fittings, it is important to mention that the fittings themselves represent only one portion of the suction entrapment scenario. Several other standards, including but not limited to, ANSI/APSP-1, -2, -3, -4, -5, -6, -8 and -9, as well as ASME A112.19.17, and ASTM F 2387-04, as outlined in para. 1.4, should be consulted to provide coverage for the various other aspects of this potential hazard in swimming pools, wading pools, spas, and hot tubs.

1.3 Units of Measurement

When values are stated in U.S. Customary units and in the International System of Units (SI), the values stated in U.S. Customary units shall be considered as the standard.

1.4 References

The following standards are referenced in this document. Unless otherwise specified, the latest edition shall apply.

ANSI/APSP-1, Standard for Public Swimming Pools

ANSI/APSP-2, Standard for Public Spas

ANSI/APSP-3, Standard for Permanently Installed Residential Spas

ANSI/APSP-4, Standard for Aboveground/Onground Residential Swimming Pools

ANSI/APSP-5, Standard for Residential Inground Swimming Pools

ANSI/APSP-6, Standard for Residential Portable Spas

ANSI/APSP-8, Model Barrier Code for Residential Swimming Pools, Spas, and Hot Tubs

ANSI/APSP-9, Aquatic Recreation Facilities

Publisher: Association of Pool & Spa Professionals, APSP, (formerly National Spa and Pool Institute, NSPI), 2111 Eisenhower Avenue, Alexandria VA 22314

ASME A112.19.17, Manufactured Safety Vacuum Release Systems (SVRS) for Residential and Commercial Swimming Pool, Spa, Hot Tub, and Wading Pool Suction Systems

Publisher: The American Society of Mechanical Engineers, ASME, Three Park Avenue, New York, NY 10016-5990; Order Department: 22 Law Drive, P.O. Box 2300, Fairfield NJ 07007-2300

ANSI/ASTM D 638, Standard Test Method for Tensile Properties of Plastics

ASTM D 256, Standard Test Methods for Determining the Izod Pendulum Impact Resistance of Plastics

ASTM D 2444, Standard Practice for Impact Resistance of Thermoplastic Pipe and Fittings by Means of a Tup (Falling Weight)

ASTM D 2466-02, Standard Specification for Poly(Vinyl Chloride, PVC) Plastic Pipe Fittings, Schedule 40

ASTM F 1498-2000, Standard Specification for Taper Pipe Threads 60° for Thermoplastic Pipe and Fittings

ASTM F 2387-04, Standard Provisional Specification for Manufactured Safety Vacuum Release Systems (SVRS) for Swimming Pools, Spas, and Hot Tubs

ASTM G 154, Standard Practices for Operating Fluorescent Light Apparatus for UV Exposure of Nonmetallic Materials

Publisher: ASTM International (ASTM), 100 Barr Harbor Drive, P.O. Box C700, West Conshohocken PA 19428-2959

IAPMO PS 33-2007a Flexible PVC Hose for Pools, Hot Tubs, Spas and Jetted Bathtubs

Publisher: IAPMO Research and Testing, 5001 E. Philadelphia St., Ontario CA 91761 USA

1.5 Definitions

anticlastic: Having opposite curvatures, as the surface of a saddle.

anti-vortex: The term anti-vortex has been misused within the industry and largely misunderstood as somehow relating to entrapment prevention. Anti-vortex outlet covers were designed to prevent an air-entraining vortex from forming. The term anti-vortex should not be construed to impart any protection and should no longer be referenced in this regard.

applicable body blocking element: A body blocking element that has a mandatory length to width ratio of 1.2777, a maximum size of 18 in. × 23 in. (457 mm × 584 mm), and a minimum size of 9 in. × 11.5 in. (229 mm × 292 mm). Its actual size for test purposes is the smallest size that will completely shadow the suction cover/grate being tested.

body-blocking element: A flat, rectangular shape with radiused corners of approved foam and backing of the torso specimen measuring 18 in. × 23 in. (457 mm × 584 mm) with 4 in. (102 mm) corner radii.

complete system: Comprising a pump, suction outlet, (and possibly inlet), and connecting piping as specified by manufacturer. No other operating components or valves may be included. Safety devices, vents, suction vacuum release systems, etc., shall be used only as specified by the manufacturer. Non-operating components such as drains are permitted.

cover: A fitting or device generally placed between the suction piping and the bather. Not used in this document to avoid confusion. See also cover/grate.

cover/grate: Covering fitting or assembly that separates the bather from the suction sump or piping, sometimes referred to as a “grate” or a “cover.”

dual outlets: Two suction outlets connected to an individual suction system but separated by a minimum of 3 feet (914 mm).

edge: The line of intersection between any two surfaces with an intersecting angle greater than 180°, measured face to face (see Figure 1), and having a transitional radius between the two faces of less than 0.75 in. (19 mm).

field fabricated: When applied to suction outlet hardware, shall indicate the use or design of conventional building materials or products, or of custom fabrication (i.e., weldments) to create specialized suction outlets.

Figure 1: Finger Probe “Edge”

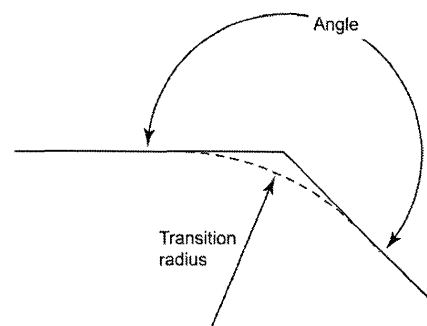

NOTE

A transition is considered an “edge” when the angle is greater than 180 deg, and the transition radius is less than 0.75 in

grate: A fitting, assembly, or panel with multiple openings in its surface. Not used in this Standard to avoid confusion. See also cover/grate.

indirect-suction: A localized area of low pressure for the transfer of water from a swimming pool, wading pool, spa, or hot tub by any means not to include suction created by the inlet side of a pump or turbine (e.g., gravity flow systems where the low pressure under a cover/grate is produced by a difference in water levels).

individual suction system: A single suction system piping arrangement that connects one or more suction outlets to one or more pumps or gravity flow reservoirs.

manufactured: When applied to fittings, fitting assemblies, cover/grates, or related devices, indicates the routine commercial production of such items for the purpose of providing suction outlet hardware for swimming pools, wading pools, spas, and hot tubs.

multiple drain use only: Indicating that the referenced suction outlet may not be used as the single sole source for water to a pump suction system.

multiple outlets: When applied to suction outlets, shall mean two or more suction outlets connected to an individual suction system.

operating component: Any component or part that can have its functionality changed.

pinch point: Any location inside the assembled suction fitting where an aperture enlarges upstream and downstream.

Q: Flow rate in cubic feet per second (ft³/sec).

registered design professional: An individual who is registered or licensed to practice their respective design profession as defined by the statutory requirements of the professional registration laws of the state or jurisdiction in which the project is to be constructed.

self-contained factory manufactured spa: A spa/hydrotherapy unit of irregular or geometric design in which all control, water heating and water circulation equipment is an integral part of the product (appliance). Self-contained factory manufactured spas are assemblies that are complete with submerged suction outlets, fittings and connecting hoses assembled into the body or the shell of the spa at the time of manufacture.

self-contained spa fittings: A fitting, fitting assembly, cover/grate, and related components that provide a localized low pressure area for the transfer of water from a Self-Contained, Factory Manufactured Spa.

single drain use: Indicating that the referenced suction outlet may be used as the single sole source for water to a pump suction system.

single or multiple drain use: Indicating that the referenced suction outlet may be used as either the single sole source for water to a pump suction system, or may be used in conjunction with additional suction outlets to a pump suction system.

skin pad: Skin-like cushion consisting of ¼ in. (6.35 mm) thick Buna-N rubber, Shore A durometer 60 ±5.

suction outlet: A fitting, fitting assembly, cover/grate, and related components that provide a localized low-pressure area for the transfer of water from a swimming pool, wading pool, spa, or hot tub.

swim jet combination fitting: A fitting that combines suction and discharge in one housing, creating a high velocity, high volume stream of water to swim, jog, or walk, as well as massage.

torso specimen: An 18 in. × 23 in. (457 mm × 584 mm) rectangular form with 4 in. (102 mm) radiused corners representing the flat portion of the 99th percentile adult male body (Mandatory Appendix I).

venturi outlets: Venturi activated indirect-suction cover/grates or venturi activated debris collection systems.

2 Fitting Design, Assembly, and Material Requirements

2.1 General Requirements

2.1.1 When fasteners are used, the suction fitting shall be designed so that tools are required for disassembly. Standard slotted screws shall not be permitted for affixing cover/grates to the suction fitting body. Fasteners shall have a corrosion resistance to the intended environment equivalent to grade 316 stainless steel as a minimum.

2.1.1.1 Threaded fasteners shall be sized to provide a minimum of three threads of engagement.

2.1.1.2 Sumps intended to receive fasteners shall be designed for fifteen secure insertion, tightening, and removal cycles of the fasteners without stripping. The design shall inhibit inadvertent cross-threading.

2.1.1.3 Sumps intended for use with self-tapping screws (those not having threaded inserts) shall be designed and constructed to accommodate redrilling for insertion of a threaded insert in a stripped hole to accept the original size fastener.

2.1.1.4 If threaded inserts are used, they shall be chosen to preclude any corrosive or chemical reaction with screws provided for the sump by the manufacturer.

2.1.1.5 Both self-tapping screws and machine screws with associated threaded inserts shall be permitted.

2.1.1.6 The strength of the fastening system shall conform to the requirements of this Standard.

2.1.2 Suction fitting assemblies that connect directly to the circulation piping shall attach by a PVC end connection in accordance with ASTM D 2466, or by a threaded end connection in accordance with ASTM F 1498.

2.1.3 There shall be no accessible sharp edges to constitute a hazard with fully assembled suction fittings.

2.1.4 Suction fittings shall not protrude from the installed surface more than 2 in. (51 mm).

2.2 Fitting Exposure

When polymeric material is used for the manufacture of suction fitting components they shall be tested as described in para. 3.2 and be rated for service life in accordance with para. 7.1.1(b)(5).

2.3 Specific Design Requirements

2.3.1 Field Fabricated Outlets. Field fabricated outlets are intended as but are not limited to a single suction outlet and are limited to 1.5 ft/sec (0.46 m/s) of flow through the open area of the cover/grate unless rated at a lower flow rate by the Registered Design Professional. They shall be of such a size that the 18 in. x 23 in. (457 mm x 584 mm) body-blocking element will not cause a differential pressure that could cause body entrapment as defined below. They are further governed by the stipulations of Mandatory Appendix II.

2.3.1.1 Suction Outlet Cover/Grates. Suction outlet cover/grates that cannot be completely covered by the 18 in. x 23 in. (457 mm x 584 mm) body-blocking element may be rated by the following formulas, which shall yield the maximum allowable flow, Q, through the cover/grate.

All calculations involve the open area of the cover/grate only.

2.3.1.2 Entrapping Force Criterion for Q

$$Q = a_R \sqrt{C \frac{F}{\rho a_B}}$$

where

a_B = largest area of the openings in ft², that can be blocked by the torso specimen in the most demanding position

a_R = area of the openings in ft² that remain unblocked

a_T = total area of the openings in ft² in the cover/grate

C = flow coefficient based on the design of the openings in the cover/grate. It shall be taken at 2.1 unless otherwise demonstrated by calculation or test.

F = allowable lifting load that can be exerted by a conscious entrapped person. It is taken at 120 lbf (534 N), about half the weight of the 99th percentile male whose weight is already entirely balanced by buoyancy.

Q = limiting flow rate in ft³/sec based on the allowable entrapping force

ρ = mass density of water

$$= \frac{62.4 \text{ lb/ft}^3}{32.16 \text{ ft/sec}^2} = 1.940 \text{ slugs/ft}^3$$

2.3.1.3 Maximum Rating, ft³/sec. The maximum rating of the cover/grate in cubic feet per second is Q.

2.3.1.4 Maximum Rating, gal/min. The maximum rating of the cover/grate in gallons per minute is Q multiplied by 7.48 gal/ft³ multiplied by 60 sec/min.

2.3.1.5 Alternate Test. As an alternate to para. 2.3.1.2, the Body Entrapment Test of section 5 may be performed.

2.3.1.6 Sump. Field fabricated outlets shall have a sump below or behind the cover/grate of the design specified by the Registered Design Professional to control flow through the open area of the cover/grate.

2.3.1.7 Design. The design of field fabricated outlets shall be further specified by a Registered Design Professional to fully address the considerations of cover/grate loadings, durability, hair, finger and limb entrapment issues, cover/grate secondary layer of protection, related sump design, and features particular to the site.

2.3.2 Venturi Outlets. Venturi outlets are outlets that are venturi activated through indirect suction through a single cover/grate generally designed for debris collection. Those that do not connect directly to the circulation piping shall have the manufacturer's recommended sump below or behind the outlet cover/grate. They are further governed by the stipulations of Mandatory Appendix II.

2.3.3 Swim Jet Combination Fittings. Swim jet combination fittings are fittings that combine suction and discharge into one housing and may be used as single inlets/outlets. They shall connect directly to the circulation piping by a PVC end connection in accordance with ASTM D 2466, or by a threaded end connection in accordance with ASTM F 1498. They are further governed by the stipulations of Mandatory Appendix II.

Figure 2: Field Built Sump

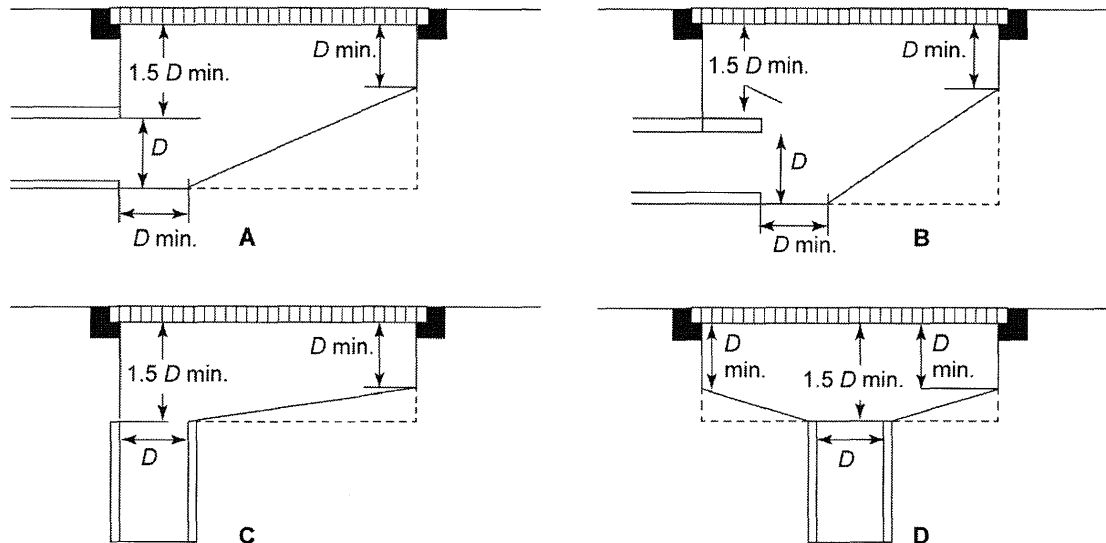

NOTES:

- (a) D = inside diameter of pipe.
 (b) All dimensions shown are minimums.
 (c) A broken line (---) indicates suggested sump configuration.

2.3.4 Submerged Suction Outlets. Submerged suction outlets are manufactured cover/grate assemblies that may or may not connect directly to the circulation piping. Those that do not connect directly to the circulation piping shall have either the manufacturer's recommended sump below or behind the outlet cover/grate, or a field built sump of the design specified by the manufacturer to control flow through the open area of the cover/grate. Alternatively, a sump built in accordance with Figure 2 shall be permitted. They are further governed by the stipulations of Mandatory Appendix II

2.3.5 Self-Contained Spa Fittings. Self-contained spa fittings shall be used exclusively in Self-Contained Factory Manufactured Spas and at least two fittings shall be used for each pump. The installation shall conform to the applicable requirements of this standard.

2.3.5.1 Installation. Self-contained spa fittings shall be installed into the body or shell of the spa at the time of spa manufacture. When used, at least two Self-Contained Spa Fittings shall be piped so that water is drawn through them simultaneously through a common line to the related pump. The use of valves or fittings capable of isolating one Self-Contained Spa Fitting from any other on the common line to the related pump shall be prohibited. This type fitting shall be connected to the tee leading to the pump utilizing only the fitting manufacturer's specified size(s) of flexible PVC hose. The flexible PVC hose specified shall conform to IAPMO PS 33.

2.3.5.1.1 Maximum Hose Length. The maximum length of hose between any self-contained spa fitting and the tee leading to the pump, shall not exceed 13 ft (396.2 cm).

3 Physical Testing

3.1 General

3.1.1 Certification. All testing and any certification of products to this Standard shall be in accordance with ISO/IEC 17025, conducted by a certification body, except for field fabrication suction outlets which shall be certified in accordance with para. 2.3.1.7.

3.1.2 Conditions for Tests and Evaluation. All tests shall be conducted at laboratory room temperature of 73.4 °F ± 3 °F (23 °C ± 2 °C) unless specified otherwise herein.

3.1.3 Test Procedure. For the tests covered in Section 3, a minimum of six suction fittings shall be tested in each test condition, unless otherwise stated. If the parts are made in different mold cavities, representative samples shall be taken from different mold cavities for a total of six. Testing shall be performed immediately after conditioning, as described in para. 3.1.5.

3.1.4 Test Fixture. The fitting(s) shall be installed in a rigid fixture that is capable of supporting the fitting(s) in a manner similar to the actual installation.

3.1.5 Conditioning. All specimens shall be submerged in water at a temperature of 73.4 °F ± 3 °F (23 °C ± 2 °C) for at least 2 hr before testing.

3.1.6 Crack Detection. After each physical test, the unit shall be washed in a standard liquid detergent solution, rinsed with clear water, and dried prior to application of ink as specified in para. 3.1.6.1. After inking, the unit shall be visually inspected in accordance with para.

3.1.6.2. To hasten drying, the surface of the unit shall be permitted to be wiped with a clean chamois leather or a clean absorbent lint-free material for this test only.

NOTE: Standard liquid detergent shall consist of (by volume):

- (a) Monsanto TKPP, 8.00%
- (b) Sterox NJ, 7.00%
- (c) Stepan SXS, 8.00%
- (d) Butyl Cellosolve, 1.5%
- (e) Water, 75.5%

3.1.6.1 Inking Procedure. The entire finished surface of the fitting shall be rubbed with a sponge and a 50% solution of tap water and water-soluble contrasting color ink after the unit has been washed and dried as described in para. 3.1.6. The ink shall be rinsed from the surface and then dried before inspection.

3.1.6.2 Method of Inspection of the Fitting Surface. The surface of the fitting shall be inspected with the unaided eye for defects from a distance of between 1 ft and 2 ft (305 mm and 610 mm). The light source shall be equivalent to an illumination intensity near the surface to be inspected of 150 fc \pm 50 fc (1615 lx \pm 540 lx).

3.1.7 Performance Requirement. The fitting shall be free from cracks. The presence of seams, flow lines, and knit lines within suction fittings shall be permitted and shall not be considered as cracks. No failures shall occur.

3.2 Ultraviolet Light Exposure Test

Either Test Method 1 or Test Method 2 may be utilized. Test Method 1 is suited for products small enough to fit into the UV test chamber, while Test Method 2 is suitable for all products.

If Test Method 1 is used, then the ultraviolet test as well as all the structural tests, are performed on the complete (as sold) samples.

If Test Method 2 is used, then the ultraviolet test is performed on "dogbone" samples molded per ASTM D 638 from the same resin as the final production samples. The tensile strength and Izod impact tests are performed on two sets of the "dogbone" samples, set A is non-exposed and set B is exposed to the ultraviolet test. In addition, all the applicable structural tests (paras. 3.3 through 3.8) are also performed on the complete (as sold) virgin samples. The performance

requirements for those tests, however, will be adjusted per para. 3.2.2.3 of this Standard.

EXCEPTION: Manufactured sumps and other fitting components that are not exposed to natural UV radiation when fully assembled and installed, according to the manufacturer's instruction, shall not be required to be included in the Ultraviolet Light Exposure Test.

3.2.1 Test Method 1. Twelve new fitting specimens shall be exposed to ultraviolet light and water spray in accordance with either:

- (a) 720 hr of twin enclosed carbon-arc (ASTM G 153, Table X1.1 Cycle 1),
- (b) 1,000 hr of xenon-arc (ASTM G 155, Table X3.1 Cycle 1), or
- (c) 750 hr of fluorescent (ASTM G 154, Table X2.1 Cycle 1).

3.2.1.1 Test Method 1. Specimens shall be mounted inside the test apparatus, with exposed surfaces of the specimens facing the UV lamps and positioned so they receive exposure approximating a fully assembled and installed cover/grate fitting. After the exposure test, the specimens shall be removed from the test apparatus and rejected if signs of deterioration such as cracking or crazing appear.

Discoloration shall not be cause for rejection. They shall then be retained under conditions of ambient room temperature and atmospheric pressure for not less than 16 hr and not more than 96 hr before being subjected to the following tests:

- (a) Deflection Tests
- (b) Point Load to Protrusion Test
- (c) Shear Load Test
- (d) Vacuum and Point Impact Test
- (e) Pull Load Test

The intensification factor K shall be 1.0 for UV Test Method 1.

The exposed specimen shall be permitted to be transported from one laboratory to another, provided time requirements are met.

3.2.1.2 Performance Requirement. All the specimens that were subject to UV Test Method 1 shall comply with all performance requirements of the structural integrity tests in paras. 3.3 through 3.8.

3.2.2 Test Method 2. Samples of the fitting polymeric materials shall be exposed to ultraviolet light in accordance with the options specified in para. 3.2.1(a), (b), or (c), Test Method 1, and then to the tests specified in paras. 3.2.2.1 and 3.2.2.2.

3.2.2.1 Tensile Strength. Samples of virgin material (A) and UV-exposed material (B) shall be evaluated for tensile strength as described in the Standard Test Method for Tensile Properties of Plastics, ANSI/ASTM D 638 (ISO 527-2) using Type 1 specimens of 0.125 in. ± 0.02 in. (3.2 mm ± 0.4 mm) thickness and testing speed of 0.2 in./min (5.1 mm/min) $\pm 25\%$. The tensile strength is to be that at the yield point if the material yields, otherwise at break.

3.2.2.2 Izod Impact. Samples of virgin material (A) and UV-exposed material (B) shall be evaluated for impact strength as described in Method A of the Standard Test Methods for Impact Resistance of Plastics and Electrical Insulating Materials, ASTM D 256 or ISO 180, using 0.125 in. (3.2 mm) thick specimen.

3.2.2.3 Performance Requirement. Samples of the material shall retain at least 70% of the unconditioned (virgin) value when the tests indicated in paras. 3.2.2.1 and 3.2.2.2 are performed. An intensification factor K shall be defined as the inverse of the lowest retained proportion. The applicable structural integrity tests, i.e., paras. 3.3, 3.4, 3.5, 3.6, 3.7, and 3.8, will be conducted on the complete (as sold) non-UV-exposed samples at loadings equal to the base values multiplied by the intensification factor, K. For example, if 80% of the tensile strength is retained in para. 3.2.2.1, and 85% of the Izod unit energy is retained, then $K = 1/0.80 = 1.25$. This will ensure that adequate strength remains after service aging.

NOTE: In the following paragraphs, the factor K is derived from para. 3.2.1.1 (Test Method 1) or para. 3.2.2.3 (Test Method 2).

3.3 Vertical Load and Deformation Test

Six fittings intended for installation in the floor or wall shall be tested.

A point load machine readable to, at a minimum, 5 lbf (22 N) increments and that is equipped with a 2 in. (51 mm) minimum diameter steel tup with a 2 in. $\pm 1/2$ in. (51 mm ± 13 mm) radius nose and a tup speed of 0.20 in./min to 0.25 in./min (5.1 mm/min to 6.4 mm/min) shall be used.

3.3.1 Test Method. Using the tup and a 2 in. (51 mm) diameter "Skin Pad" on the face of the tup, and tup speed described in para. 3.3, the six fittings shall be mounted in a horizontal plane and tested. The "Skin Pad" is a 1/4 in. (6.35 mm) thick Buna-N rubber pad of Shore A durometer 60 ± 5 hardness. The tup and pad shall be centered

- (a) on the fitting face
- (b) at two points midway between the center and edge
- (c) at two points between stiffeners, if any
- (d) at two points furthest from any support post.

A load is applied at each of the above locations until 300 lbf ± 10 lbf (1 334 N ± 44 N) is reached.

3.3.2 Performance Requirement. Suction fittings shall not permanently deform, crack, or lose any material from the fitting, exclusive of plating or finish.

3.4 Horizontal Load and Deformation Test

Fittings to be tested shall be the six as previously tested in para. 3.3. This test is identical to the Vertical Test except that the load is 150-lbf ± 5 lbf (667 N ± 22 N). This applies only to fittings intended for and marked "Wall Only" or "Wall or Floor."

3.5 Point Load to Excess Test

Fittings to be tested shall be the six as previously tested in paras. 3.3 and 3.4, loaded in the same manner.

3.5.1 Test Method. The test equipment to be used shall be the same and positioned as described in para. 3.3, with "Skin Pad." The units shall be subjected to additional loading, with a load speed of 0.20 in./min to 0.25 in./min (5.1 mm/min to 6.4 mm/min), until the tup protrudes through the cover/grate or until a value of 600 lbf $\times K \pm 10$ lbf (2 669 N $\times K \pm 44$ N) is reached.

3.5.2 Performance Requirement. Suction fittings shall not sustain loss of any material from the fitting, exclusive of plating or finish upon protrusion, or when a value of 600 lbf $\times K \pm 10$ lbf (2 669 N $\times K \pm 44$ N) is reached. Permanent deformation shall not be considered a failure.

3.6 Shear Load Test

Six fittings shall be tested. They shall be those from the Ultraviolet Light Exposure Test (para. 3.2). This test shall be applied to all fittings that protrude 1/2 in. (13 mm) or more from the mounting plane.

3.6.1 Test Method. The fitting shall be tested by the application of a 150 lbf $\times \pm 5$ lbf (667 N $\times K \pm 22$ N) test load applied 30° from the mounting plane by a loading face 2 in.² (645 mm²) covered with a 2 in. \times 2 in. (51 mm \times 51 mm) "Skin Pad" on its face. The six fittings shall be tested using the point load machine described in para. 3.3. Three fittings shall be tested with fasteners directly in line with the load to test the fastener's strength, and three shall be tested with the load midway between fasteners for general strength.

3.6.2 Performance Requirement. The cover/grate shall remain in place. The fitting shall not permanently deform, crack, or lose any material exclusive of plating and finish.

3.7 Pressure Differential and Point Impact Test.

The same six fittings used in the Shear Load Test (para. 3.6) shall be tested.

3.7.1 Test Method

(a) The fitting to be tested shall be mounted on a horizontal surface and covered with a 20 mil (0.5 mm) plastic material or other suitable material. The fitting outlet shall be connected to a vacuum or pressure (pressure will be required for K factors greater than 1.0) system and it shall be subjected to a 28.5 in. (724 mm) Hg \times K vacuum within 60 sec \pm 5 sec. The vacuum shall be sustained for 5 min \pm 10 sec.

(b) The vacuum or pressure shall be removed from the system, and the fitting shall be impacted at 15 ft/lbf \times K (20.3 J \times K) using the test method in ASTM D 2444, with a 5 lb (2.3 kg) steel tup, 2 in. (51 mm) minimum diameter with a 2 in. \pm 1/2 in. (51 mm \pm 13 mm) radius nose. The tup shall be dropped from a distance of 3 ft \times K (914 mm \times K) aligned with the center of the fitting.

(c) The fitting shall be again connected to the vacuum or pressure system and again it shall be subjected to the 28.5 in. (724 mm) Hg \times K differential pressure within 60 sec \pm 5 sec. The differential shall be sustained for an additional 5 min \pm 10 sec.

After removal from the test fixture, water-soluble contrasting ink shall be applied in accordance with paras. 3.1.6 and 3.1.6.1 and the fitting shall be inspected for cracks, breaks, or fractures in accordance with para. 3.1.6.2.

3.7.2 Performance Requirement. The cover/grate shall remain in place after the test procedures in paras. 3.7.1(a) through (d). The fitting shall not permanently deform, crack, or lose any material from the fitting exclusive of plating and finish.

3.8 Pull Load Test

Pull Load Testing shall be required of all fittings with openings of 0.375 in. (9.53 mm) or more affording a finger grip. The measurements shall be done on the anticlastic surface when required for the hair test, para. 4.1.5.7. The same six fittings used in the Vacuum and Point Impact Test (see para. 3.7) shall be tested.

3.8.1 Test Method. The cover/grate shall be tested by the application of a 150 lbf \times K \pm 5 lbf (667 N \times K \pm 22 N) test load to the underside of the cover/grate assembly and perpendicular to the mounting surface that will approximate the load bearing points available to a bather's three fingers directly adjacent to fasteners, and midway between fasteners when the fitting is installed in accordance with the manufacturer's instructions.

3.8.2 Performance Requirement. The cover/grate shall withstand a 150 lbf \times K (667 N \times K) pulling force. Distortion under load shall not compromise the fastener(s), loosen the cover/grate, permanently deform, or crack the fitting.

3.9 Mold Stress Relief Distortion

3.9.1 Test Method. One sample of the complete (as sold) non-UV-exposed fitting is to be placed in a full draft circulating air oven maintained at a uniform temperature of 140 °F (60 °C). The sample is to remain in the oven for 7 hr. The sample is then to be removed from the oven, and be allowed to return to room temperature.

3.9.2 Performance Requirement. This sample shall be used for the Hair and Body Entrapment Tests to ensure compliance therewith.

4 Hair Entrapment

4.1 General

4.1.1 Impedance. Hair drawn into or on suction fittings shall not impede the escape of a bather.

4.1.2 Sample Types. Two types of hair shall be used in this test and separate tests shall be run with each type.

4.1.2.1 Type 1. A full head of natural, fine, straight, blond European, human hair with cuticle on hair stems, 16 in. (406 mm) in length, 5.5 oz \pm 0.5 oz (155 g \pm 15 g), shall be firmly affixed in a manner approximating the normal distribution of hair with "hook and loop" to a Professional Wig Display Mannequin, Model No. FMH #1SC, or equivalent, properly weighted to achieve neutral buoyancy under the water. A scale anchoring point shall be provided near the "neck" of the "skull." A fresh sample of hair shall be used for each fitting tested or when tangles in the hair cannot be removed. Hair shall be trimmed evenly.

4.1.2.2 Type 2. Natural, medium to fine, straight, light-brown colored human hair weighing 2 oz \pm 0.11 oz (57 g \pm 3 g) and having a length of 16 in. (406 mm) shall be affixed to a 1 in. (25 mm) diameter by 12 in. (305 mm) wooden dowel as may be required to properly place the hair sample for testing.

Consideration shall be given to the buoyancy of the portion of the wooden dowel in excess of 12 in (305 mm) in determining the removal force. A method for attaching a scale shall be provided on the opposite end of the dowel. A fresh sample of hair shall be used for each fitting tested or when tangles in the hair cannot be removed. Hair shall be trimmed evenly.

4.1.3 Suction Fitting. Only one new suction fitting shall be required to be tested.

4.1.4 Field Fabricated Outlets. For field fabricated outlets, hair entrapment tests are not required, but velocity through cover/grate openings shall not exceed 1.5 ft/sec (4.675 gpm/in.²) [457 mm/sec (2.73 Lpm/cm²)] of open area.

Figure 3: Test Tank Pull Mechanism

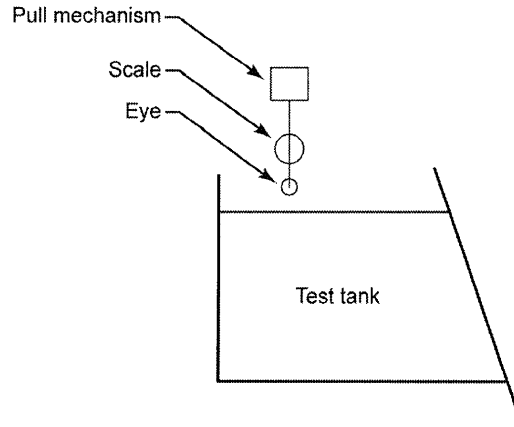

Figure 4: Test Tank Side View

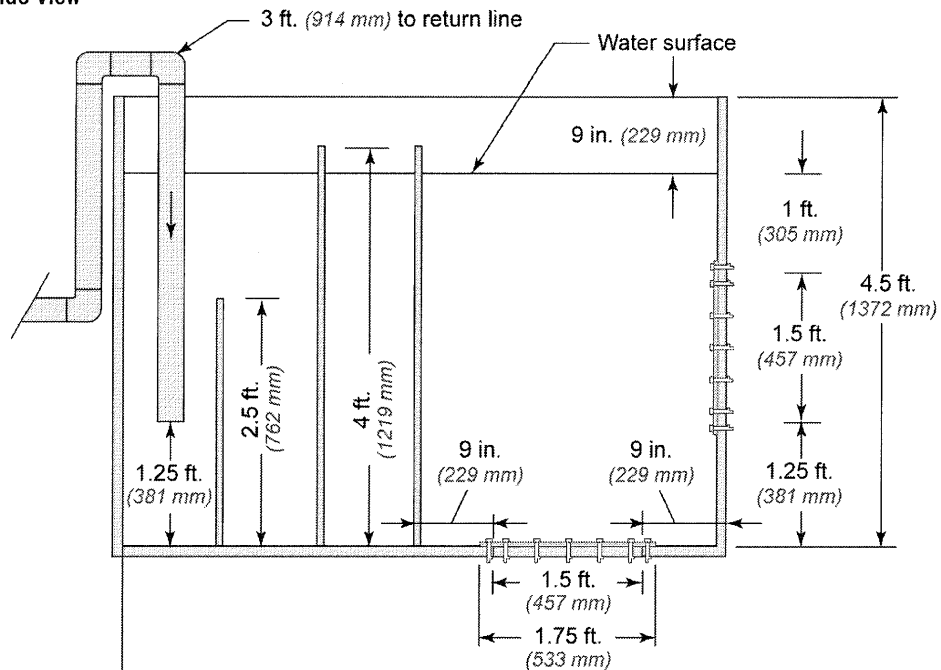

Figure 5: Test Tank Top View

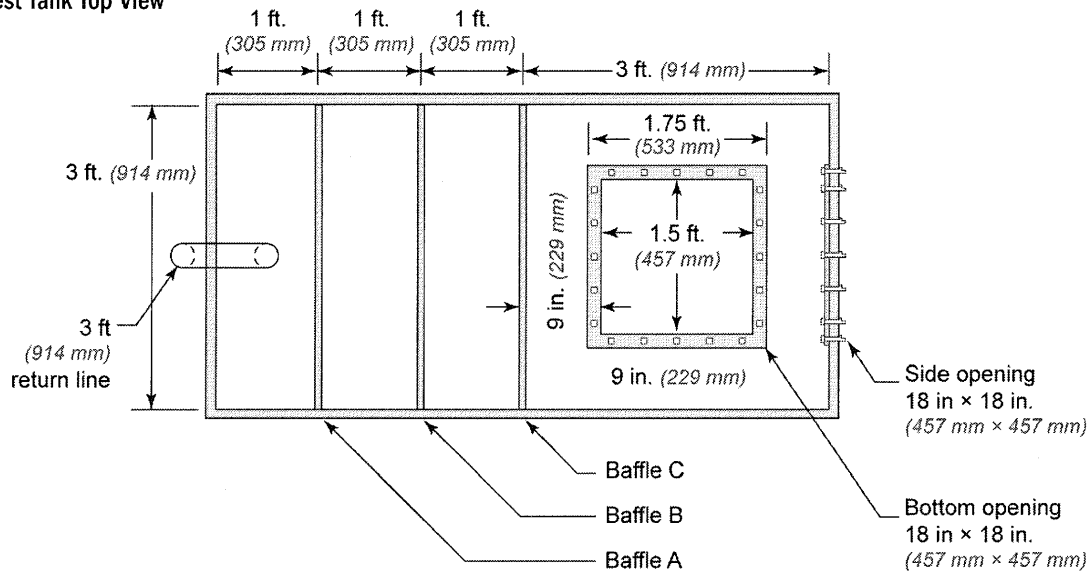

Figure 6: Test Tank Mounting Plate

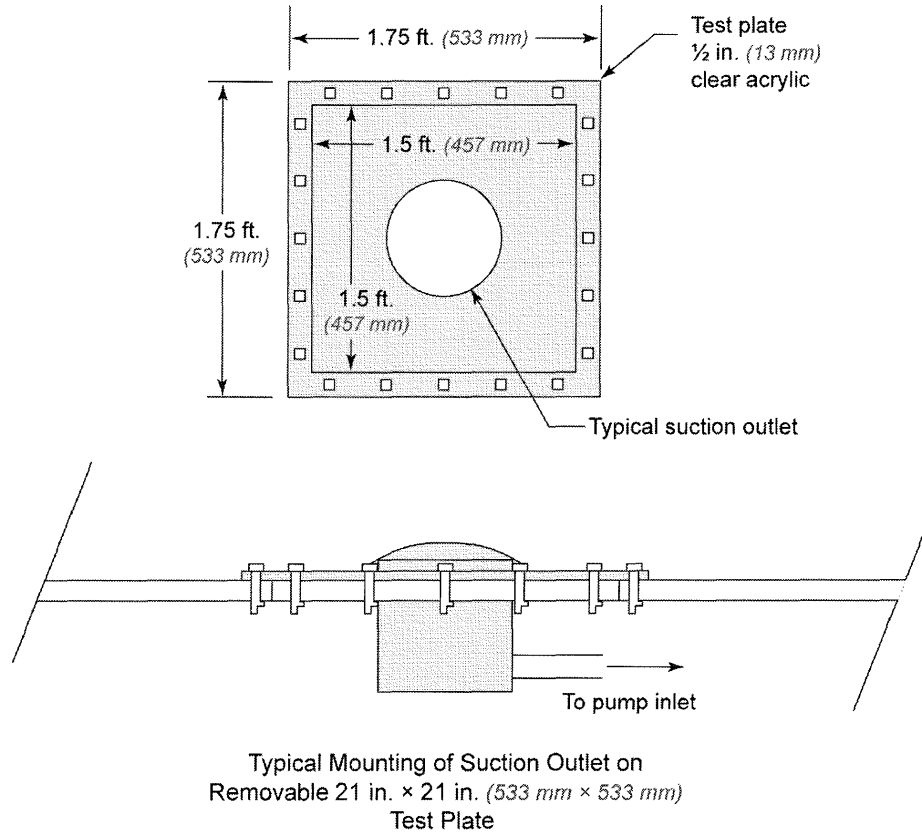
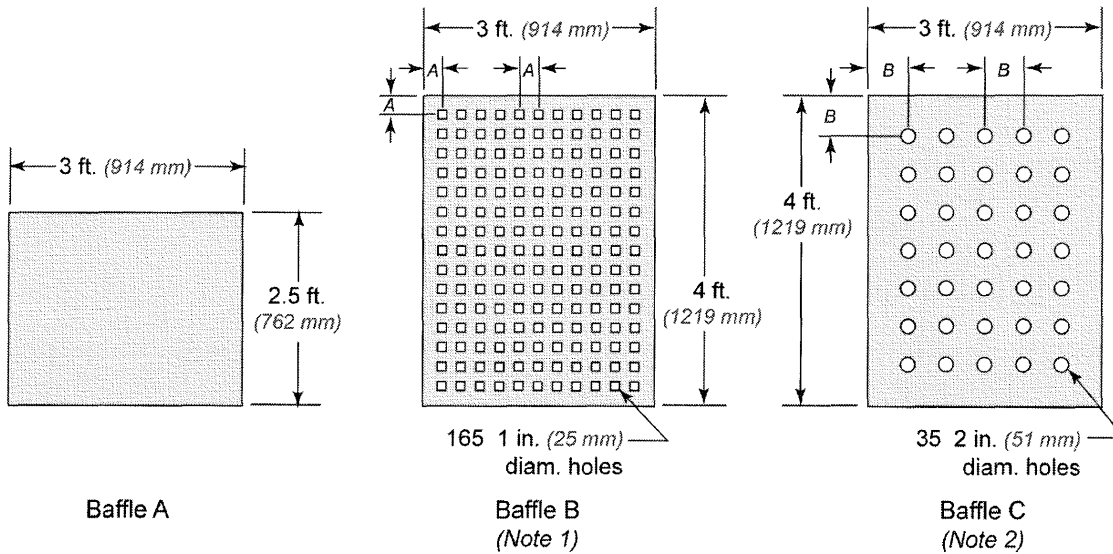

Figure 7: Test Tank Baffles



NOTES:
Baffles made of 1/2 in. (13 mm) clear acrylic.
(1) A = 3 in. (76 mm)
(2) B = 6 in. (152 mm)

4.1.5 Test Equipment

4.1.5.1 Test Tank. The test tank for evaluation of suction fittings for the hair entrapment test shall be in accordance with Figures 4, 5, and 6. The baffle plates shall be constructed as shown in Figure 7 and be positioned as shown in Figures 4 and 5.

4.1.5.2 Pump. A properly grounded pump capable of producing a flow rate of at least 25% greater than the fitting manufacturer is recommended rating of the fitting shall be used. A rate of flow meter with an accuracy of $\pm 3\%$ at the anticipated cover rating shall be installed in the piping system.

4.1.5.3 Pump Inlet. The pump inlet shall be connected to the 16 in. (406 mm) length of Schedule 40 plastic pipe using pipe lengths and adapters as necessary.

4.1.5.4 Scale. A scale accurate within 0.1 lbf (0.45 N) at a tension of 5 lbf (22 N) shall be used to determine pounds of pull against the entrapment.

4.1.5.5 Test Fixture. The hair entrapment test fixture shall be comprised of the test tank (Figures 4 through 7), the mechanical appurtenances, and the pull mechanism (Figure 3).

4.1.5.6 Mounting Surface. For assemblies where all flow passages are provided by the manufactured components, the mounting surface of Figure 6 shall be planar.

4.1.5.7 Test Procedure. For assemblies where a portion of the flow passage is the pool surface and is not controlled by the suction outlet manufacturer, the test-mounting surface shall represent field imperfections that may produce a hair entrapment hazard.

The nominally square planar mounting surface shall be distorted to an anticlastic (warped or saddle-shaped) surface such that one corner is 2 in. (51 mm) away from a plane defined by the other three corners of a 48 in. \times 48 in. (122 mm \times 122 mm) square as shown in Figure 8. A convenient means shall support three of the corners in a plane with 1 in. (25 mm) clearance from the nearby surface of the frame. Then force the fourth corner 2 in. (51 mm) from the plane of the first three. Supports shall be localized, and 1.5 in. (38 mm) from the edges of the mounting surface. The test specimen shall be firmly attached to the anticlastic surface in a field installation manner as specified by the manufacturer.

4.1.6 Alternate Test Tank

4.1.6.1 Depth of Tank. The same tank as described in para. 4.1.5.1, with baffles, bottom, sides, and only the one end where the fittings are tested may be used by the insertion of the tank into a larger body of water, so that the submerged depth of the tank is the same as in para. 4.2.3.

4.1.6.2 Water Volume. The volume of the water in this larger body of water shall substitute for the return line piping depicted in Figures 4 and 5.

4.1.6.3 Alternate Test Pool. Any other body of water may be used, provided the body of water gives equivalent test results as intended by this Standard.

4.1.6.4 Water Currents. Influences of water currents shall be virtually absent in the test pool as evidenced by the suspension of the hair sample in the tank for 30 sec and noting its deviation from a vertical plumb line hung at a distance from the nonflowing test specimen of four times the least dimension of the test cover/grate. The deviation shall not exceed 1 in. (25 mm) during this time.

Figure 8: Anticlastic Mounting Surface (Typical)

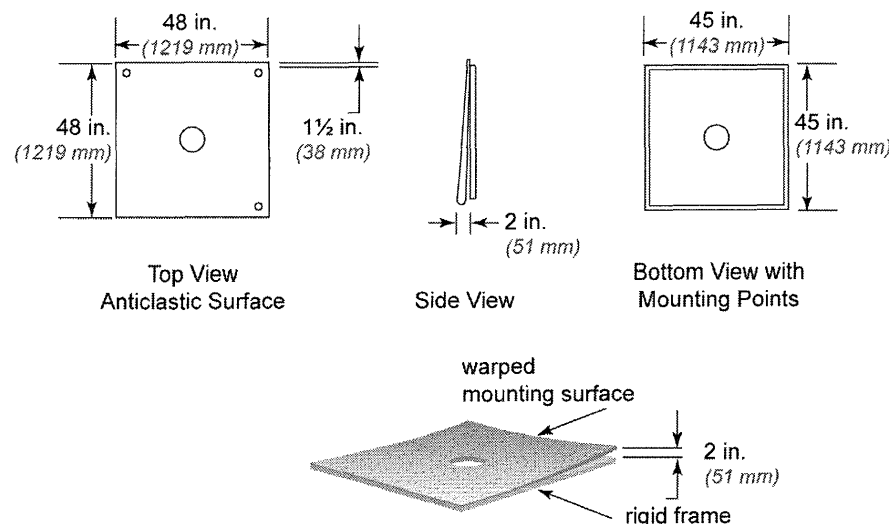
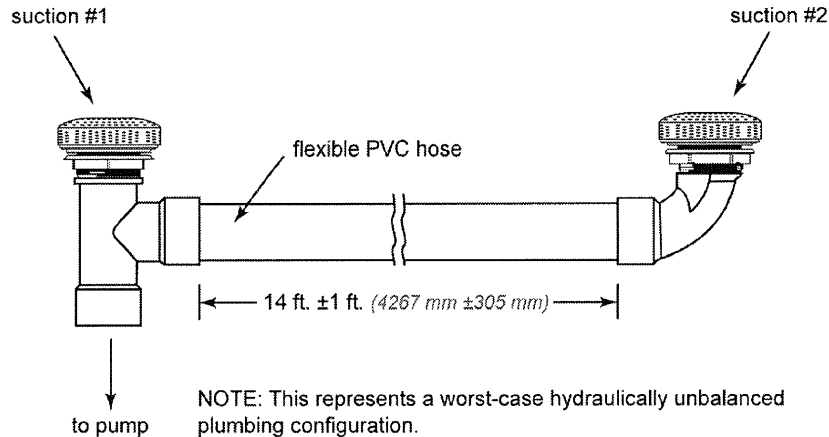

Figure 9: Hair Test Configuration for Self-Contained Spa Fittings



4.2 Test Method

4.2.1 Testing requirements shall be in accordance with paras. 4.1.3 and 4.1.4.

4.2.2 The suction fitting including the sump to be tested (see Figure 6) shall be installed in accordance with manufacturer's installation instructions on the test drain-mounting surface. For suction fittings intended for wall installation, the test-mounting surface shall be placed in the vertical position, and for suction fittings intended to be installed only in the floor installation, the test-mounting surface shall be placed in the horizontal position. Suction fittings intended for installation in either the wall or floor position shall be tested in both positions. For fittings tested in the vertical position, if the pattern of the cover/grate is not uniform, it shall be tested in two positions, representing the essential geometric differences. The fitting shall be connected to a 90° elbow the same size of the fitting outlet, and as close to the suction fitting as possible, with a minimum of 16 in. (406 mm) of straight Schedule 40 plastic pipe the same size as the fitting socket connected to the 90° elbow.

4.2.2.1 Self-Contained Spa Fittings shall be installed in pairs on the test suction outlet mounting surface using 14 ft ±1 ft (4267 mm ±305 mm) of flexible PVC hose in accordance with Figure 9. The size(s) of the flexible PVC tubing shall be specified by the self-contained spa fitting manufacturer. When more than one size of hose is specified, each size shall be tested. Suction #1, shown in Figure 9, shall be tested for hair entrapment in accordance with paras. 4.2.3 through 4.3.

4.2.3 The tank shall be filled with water at a temperature at 90 °F ±10 °F (32 °C ±6 °C) to a depth of 12 in. ±½ in. (305 mm ±13 mm) above the top edge of the cover/grate, or to a depth in accordance with the manufacturer's instructions for swim jet combination fittings.

4.2.4 Prior to energizing the test pump, the pull mechanism shall be verified to ensure a consistent speed when pulling weights from 2 lbf to 10 lbf (8.9 N to 44 N). Within that range of test weights, the speed of the pull shall be 5 in./sec ±0.25 in./sec (127 mm/sec ±6 mm/sec).

4.2.5 The test pump shall be activated and the flow shall be regulated to 10 gpm (38 L/min) less than the fitting manufacturer's recommended gpm flow rate. If the fitting rating is not known, this test shall be started at 25 gpm (95 L/min). The fitting manufacturer may specify the starting test flow rate for each fitting to be tested.

4.2.6 Prior to use, the hair shall be cleaned in a 10% volume of Sodium Alpha Olefin Sulfonate (AOS) and water. After cleaning thoroughly, rinse in potable water. Hair samples shall be cleaned after every ten pulls. Dry hair shall be saturated for a minimum of 2 min in the test tank. When saturated, the hair shall be placed on the dowel/human skull and attached to the piston. When testing on a vertical fitting, the free end of the hair shall be placed approximately 12 in. (305 mm) in front of the suction fitting, 2 in. (51 mm) above the face of the fitting, as illustrated in Figure 10.

4.2.7 In both tests the hair shall be slowly moved closer to the suction portions of the fitting, and the ends of the hair shall be fed into the fitting in the direction of the intake flow as illustrated in Figure 10. The hair shall be continually fed into the fitting while moving the skull or dowel from side-to-side in a sweeping motion.

The magnitude of the sweeping motion shall be reduced with each pass of the skull or dowel. The hair shall be fed into the fitting over a period of 60 sec ±5 sec. Then the skull or dowel end shall be held against the fitting for 30 sec ±5 sec. The skull or dowel shall then be released and allowed to float or remain free for 30 sec ±5 sec.

Figure 10: Hair Test Diagrams

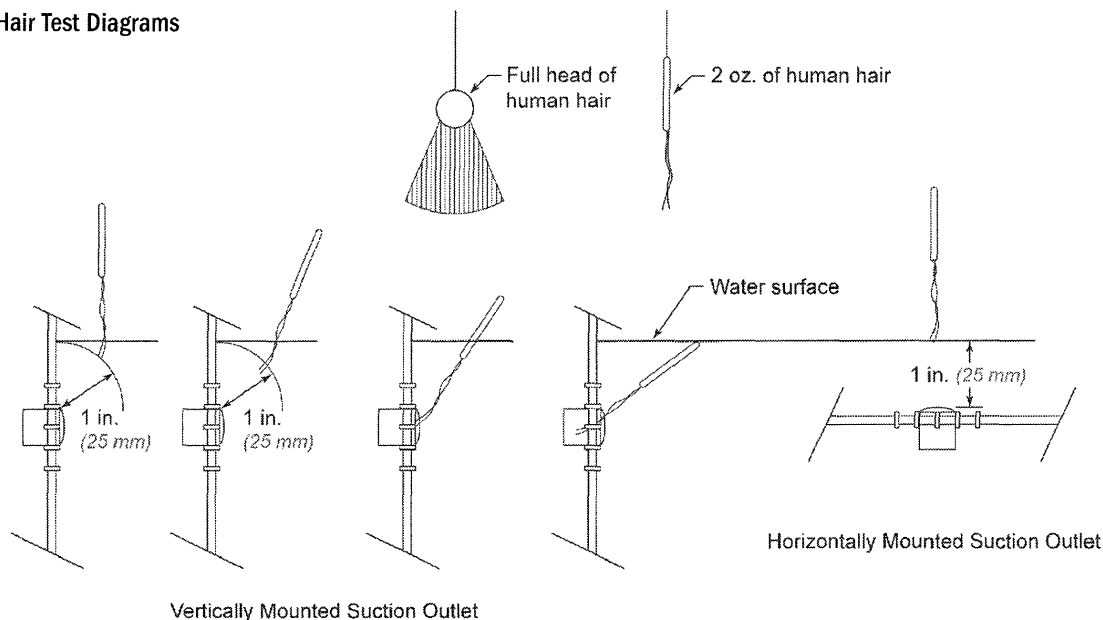

NOTE: Showing 2 oz. hair test. Same to be performed with full head of hair.

4.2.7.1 If testing a horizontal fitting, testing shall start with the end of the hair 2 in. (51 mm) above the fitting in a similar sweeping motion.

4.2.7.2 In testing any fitting which is not entirely symmetric, or those mounted on an anticlastic surface, testing shall start with the end of the hair 2 in. (51 mm) from all representative locations around the fitting.

4.2.8 The flow rate shall be increased in 5 gpm (19 L/min) increments $\pm 3\%$ and ten tests shall be performed at each flow rate. Brush hair prior to each test to keep tangle-free.

4.2.8.1 With the test pump still operating, the amount of force necessary to free the hair from the fitting shall be measured. The skull or dowel shall be attached to the scale and the scale shall be zeroed and then pulled in a vertical orientation away from the fitting by activating the hair removal mechanism. The force of the entrapment shall be measured and recorded. A sample reporting form for recording the data is provided in non-mandatory Appendix A.

4.2.8.2 Where a failure is determined with a specific 5 gpm (19 L/min) increase, the unit shall be permitted to be retested in 1 gpm (3.8 L/min) increments up to the point of the previous failure in order to determine the rating under this section.

4.3 Performance Requirement

A pull of 5 lbf (22 N) or greater on any one of the ten tests, including the equalized weight of the saturated test apparatus, shall be deemed a failure, and the flow rate in gpm at failure shall be recorded. If one failure in ten pulls occurs, repeat the test ten more times.

All additional tests shall pass before moving to the next value. The highest passing flow rate shall be divided by 1.25 to determine the maximum allowable rating of the suction fitting unless the manufacturer has set a lower flow rate, which then shall be the rating of this fitting.

5 Body Entrapment

5.1 General

5.1.1 Design and Installation. Suction fittings shall be designed and installed to reduce the potential for body entrapment. The potential for body entrapment is addressed by the proper selection of the size of outlet cover/grate or the proper installation of more than one suction outlet.

5.1.2 Fittings

5.1.2.1 Body Entrapment Test shall apply to all fittings and suction outlets covered under this Standard. For manufactured fittings only one new fitting shall be required to be tested.

5.1.2.1.1 Self-Contained Spa Fittings shall be tested for conformance with Section 5 Body Entrapment using a single-outlet configuration. The Body Entrapment Test shall not be performed using the configuration of para. 4.2.2.1.

5.1.2.2 Suction outlet cover/grates that cannot be completely covered by the 18 in. \times 23 in. (457 mm \times 584 mm) body blocking element may be rated by either the test procedures called for in this section or by calculation in accordance with para. 2.3.1.

Figure 11: Body Block Element

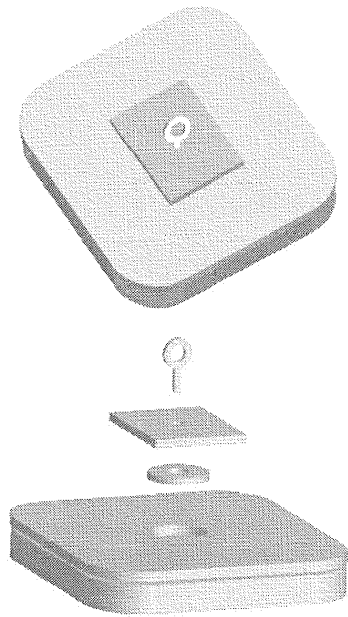
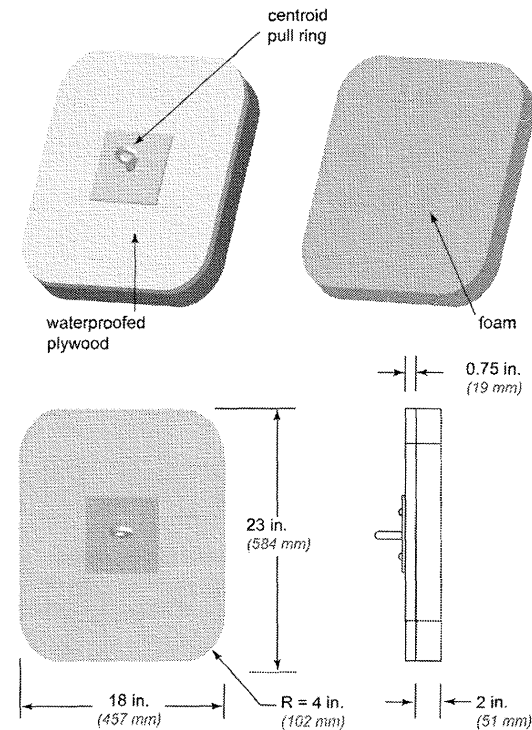

Figure 12: Body Block Element Dimensions



5.1.3 Test Equipment. A torso specimen is defined as a rectangular form representing the flat portion of the 99th percentile adult male body (Mandatory Appendix I). Representing this form for test purposes is the body block element that is an 18 in. \times 23 in. \times 2 in. (457 mm \times 584 mm \times 51 mm) section of foam identified as “Closed Cell NBR/PVC Foam with a compression deflection value of 1.5 psi to 3.0 psi (10 kPa to 21 kPa) at 25% deflection as measured in accordance with ASTM D 1056-00.” It shall be mounted against an 18 in. \times 23 in. \times $\frac{3}{4}$ in. (457 mm \times 584 mm \times 19 mm) waterproofed plywood backing, with the skin side away from the plywood, with an eyebolt, hitching ring, or equivalent at the centroid as shown in Figures 11 and 12. The specimen shall be ballasted to neutral buoyancy, within 0.7 lbf (3.1 N), at the test depth.

Corners of the applicable body-blocking element as well as the body-blocking element shall be radiused with a radii of 22% of the width dimension.

5.2 Test Method

5.2.1 With the outlet flowing at the smaller of the maximum flow specified by the manufacturer or designer or as determined in para. 4.3, the 18 in. \times 23 in. (457 mm \times 584 mm) body block element, concentrically loaded, shall be placed on the cover/grate with an applied force of 120 lbf (534 N) and in such a position as to be centered or cover the largest area of the cover/grate.

5.2.1.1 For purposes of calculating the maximum allowable release force, the smallest blocking element that will completely shadow the suction outlet cover/grate being tested shall be referred to as the applicable body-blocking element.

5.2.1.2 Applicable body blocking elements may range in size from the 18 in. \times 23 in. (457 mm \times 584 mm) size down to a minimum dimension of 9 in. \times 11.5 in. (229 mm \times 292 mm) as given in Table 1. Corners shall be rounded with a radius of 22% of the width dimension.

5.2.2 Swim jet combination fittings shall be tested by placing the body-blocking element fully against and centered on the fixture faceplate with a force of 120 lbf (534 N).

5.3 Performance Requirement

5.3.1 Under these test conditions, to pass the Body Entrapment Test, the maximum allowable removal force (in pounds), immediately after the 120 lbf (534 N) applied force is released, shall be based on the following calculation using the width of the smallest applicable body blocking element. This maximum shall not be exceeded in three consecutive tests.

NOTE: See Table 1 for computation of the maximum removal force.

Bather	Min. Width Blocking Element to Shadow Tested Cover	Blocking Element Length = $1.2777 \times \text{Width}$	Basis is Child Width	Ratio of Element Width to Child Width	Ratio Cubed	Times Child Weight = 30 lb	One-Half Weight	Maximum Removal Effort No.
99th percentile male	51	23.0	9	2.00	8.00	240	120	120
	17.5	22.4	9	1.94	7.35	221	110	110
	17	21.7	9	1.89	6.74	202	101	101
	16.5	21.1	9	1.83	6.16	185	92	92
	16	20.4	9	1.78	5.62	169	84	84
	15.5	19.8	9	1.72	5.11	153	77	77
	15	19.2	9	1.67	4.63	139	69	69
	14.5	18.5	9	1.61	4.18	125	63	63
	14	17.9	9	1.56	3.76	113	56	56
	56	17.2	9	1.50	3.38	101	51	51
	13	16.6	9	1.44	3.01	90	45	45
	12.5	16.0	9	1.39	2.68	80	40	40
	12	15.3	9	1.33	2.37	71	36	36
	11.5	14.7	9	1.28	2.09	63	31	31
	11	14.1	9	1.22	1.83	55	27	27
	10.5	13.4	9	1.17	1.59	48	24	24
	10	12.8	9	1.11	1.37	41	21	21
9.5	12.1	9	1.06	1.19	35	18	18	
3 year old child	9	11.5	9	1.00	1.00	30	15	15

NOTES:

(a) All dimensions in inches (1 in. = 25.4 mm)

(b) This Table calculates the maximum removal effort that shall be required to remove the body blocking element from the cover/grate being tested as based on the width of the applicable body blocking element. Intermediate values may be calculated using the formula $(\text{width}/9)^3 \times 15$
Example: $10.7/9 = 1.188$; $1.188^3 = 1.68$; 168 multiplied by 15 = 25.2 lbf

5.3.2 Where a failure is determined at the tested flow rate as specified in para. 5.2.1, the unit shall be allowed to be tested in 5 gpm (19 L/min) decreases until the unit passes. The unit shall then be permitted to be retested in 1 gpm (3.8 L/min) increments up to the point of the previous failure in order to determine its rating under this section.

6 Finger and Limb Entrapment

6.1 General

6.1.1 Design and Installation. Suction fittings shall be designed and installed to reduce the potential for digit or limb entrapment.

6.1.1.1 When fully assembled, suction fittings shall not have any accessible opening that allows the passage of the 1 in. (25 mm) cylindrical end of the UL Articulate Probe.

6.1.2 Small Aperture. A small aperture is an opening with two or more dimensions smaller than 1 in. (25 mm) (see Figure 13, p. 16).

6.1.3 Large Aperture. A large aperture is an opening with only one dimension smaller than 1 in. (25 mm) (see Figure 13).

6.1.4 Suction Outlet Testing

6.1.4.1 All suction outlets covered under this Standard shall be subjected to the following test.

6.1.4.2 Finger Entrapment Tests shall be conducted on one new suction fitting from each mold cavity.

6.1.5 Conditions for Tests. Tests shall be conducted at room temperature using new dry fittings.

6.1.6 Conditions Using UL Articulate Probe. Tests shall be conducted with the UL Articulate Probe in accordance with Figures 1, 13, 14, 15, and 16.

6.2 Test Method

Each aperture on the assembled suction fitting shall be subjected to the insertion of both ends of an UL Articulate Probe. Using 3 lbf (12 N) $\pm 5\%$, the Articulate Probe shall be urged through all exposed apertures of the assembled suction fitting.

6.3 Performance Requirement

A small or large aperture is permitted when the 1 in. (25 mm) cylindrical end of the UL Articulate Probe cannot be made to penetrate through to the inside surface of the aperture and as follows:

Figure 13: Finger Probe–Finger and Limb Entrapment Test

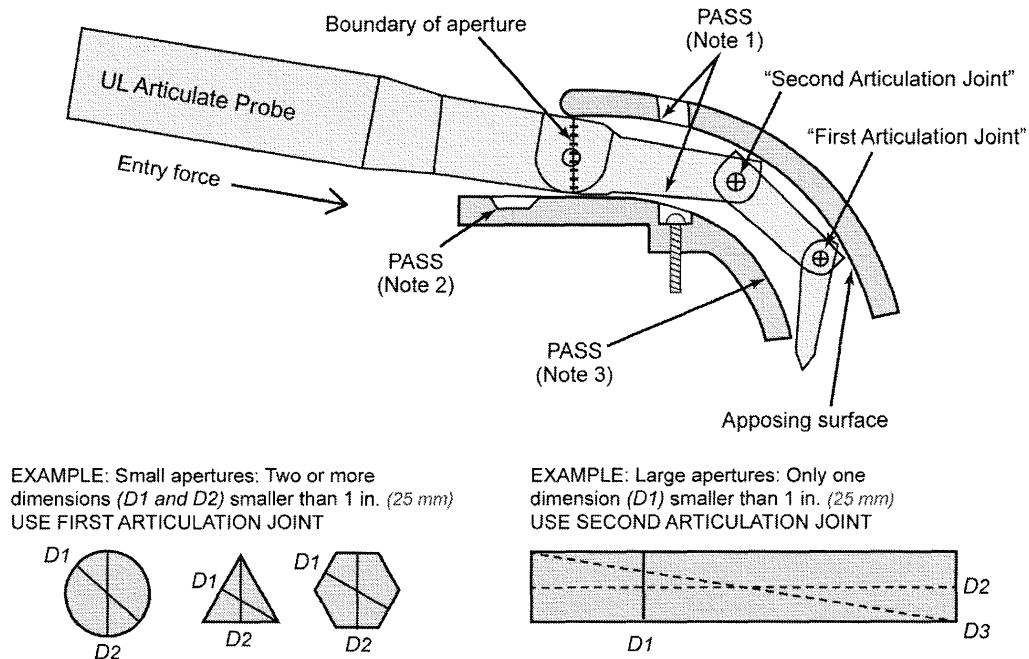

- NOTES:
1. "Edges" inside aperture are less than 0.311 in. (7.9 mm) wide and there are no protrusions above the aperture surface.
 2. An "edge" wider than 0.311 in. (7.9 mm) but it is outside the aperture.
 3. Transitional radius > 0.79 in (19 mm).

Figure 14: Finger Probe

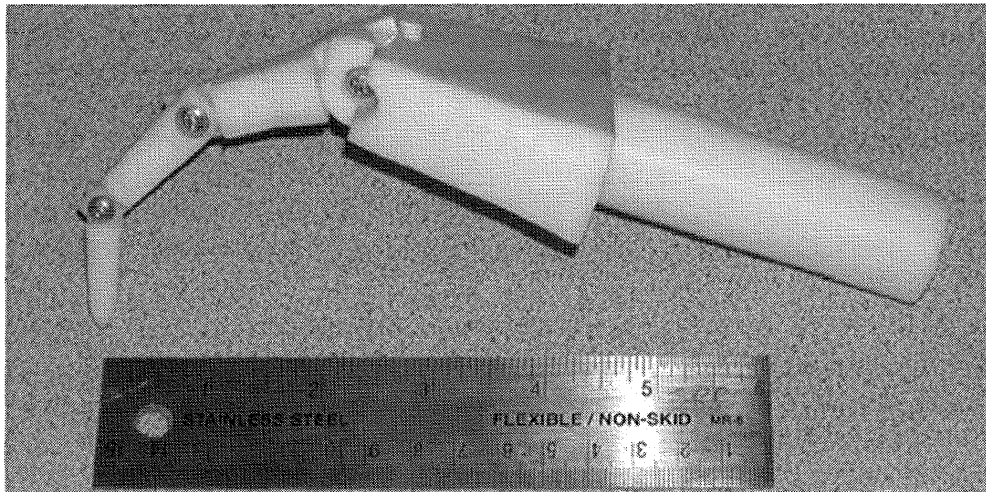

Figure 15: Finger Probe Dimensions

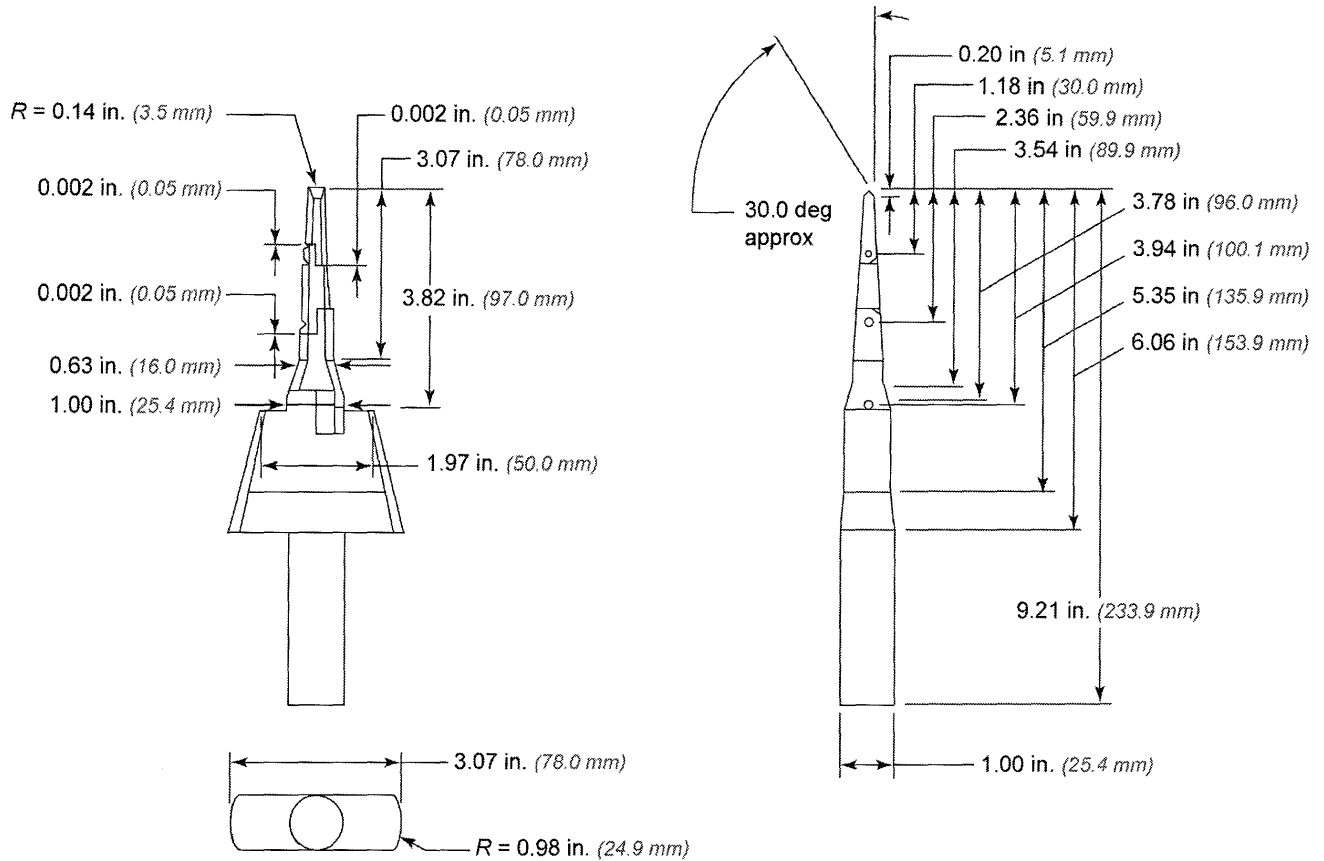
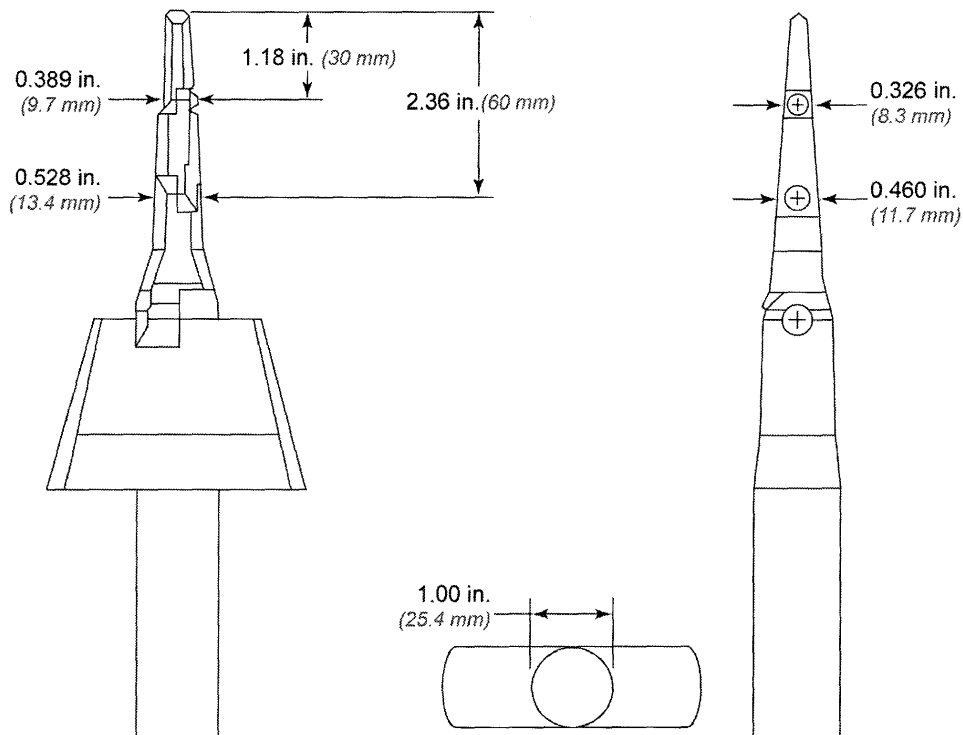

Figure 16: Finger Probe Knuckle Dimensions



(a) Small apertures shall be permitted when the centerline of the first articulation joint, located 1.18 in. (30 mm) from the point end of the UL Articulate Probe, cannot be made to pass beyond an edge or pinch point that is located inside the aperture being tested. (See Figure 1, p. 2.)

(b) Large aperture(s) shall be permitted when the centerline of the second articulation joint, located 2.36 in. (59.9 mm) from the point end of the UL Articulate Probe, cannot be made to pass beyond an apposed edge or pinch point that is located inside the aperture being tested. (See Figure 13.)

(c) Edges and pinch points shall be permitted within the aperture and within range of the first articulate joint in accordance with Figure 13 if they are less than 0.311 in. (7.9 mm) wide, measured parallel to the aperture opening.

(d) Edges and pinch points created by molding lines, engraved text, and symbols shall be permitted within the aperture provided they do not exceed a height of 0.025 in. (0.64 mm).

7 Packaging and Installation Instructions

7.1 Marking of Suction Fittings

7.1.1 Fittings that comply with ASME A112.19.8 shall be permanently marked as follows in a manner that is visible in the installed position and where the text is no smaller than 0.08 in. (2.03 mm) tall:

(a) The following is an example of a typical marking:

EXAMPLE:

For Multiple Drain Use Only

108 GPM

Swim Jet Life: 7 Years

Wall Only

Quantum 1563-W

(b) The positioning or arrangement of this marking shall be in the following sequence when possible:

(1) Certification markings as required by responsible jurisdictional authority.

(2) The statement "For Single or Multiple Outlet Use," "For Single Outlet Use," or "For Multiple Outlet Use Only." Self-contained spa fittings shall be marked with "For Use in Self-Contained Factory Manufactured Spas Only" and "For Multiple Outlet Use Only."

(3) The lesser of the maximum flow rate in gpm as determined in accordance with para. 2.3.1.4, 4.3, or 5.3.2. A fitting shall be permitted to be marked

with multiple flow rates (i.e., a flow rating for "Floor" installations and another for "Wall" installations).

(4) The "Type" of the fitting in accordance with para. 1.1.6.

(5) Fitting components shall be marked "Life: X Years" where the manufacturer indicates the appropriate installed life in years. Individual components may be marked with unique life spans.

(6) Installation position— "Wall Only," or "Floor Only," or "Wall or Floor" if allowed in both positions.

(7) Manufacturer's name or registered trademark.

(8) Model designation.

7.1.2 As an alternate to marking field fabricated outlets, the owner of the facility where these fittings will be installed shall be advised in writing by the Registered Design Professional the information called for in paras. 7.1.1(b)(1) through (8).

7.2 Packaging of Suction Ratings

7.2.1 The packaging and installation instructions for manufactured fittings shall contain

(a) information on installation and service, including:

(1) type designation in accordance with para. 1.1.6, including any requirement for multiple outlets required per pump

(2) instructions not to locate suction outlets on seating areas or on the backrests for such seating areas

(3) instructions stating that when two or more suction fittings are used on a common suction line, they shall be separated by a minimum of 3 ft (914 mm), or if any are located closer, they shall be located on two different planes (i.e., one on the bottom and one on the vertical wall, or one each on two separate vertical walls), such that it is unlikely both could be simultaneously blocked

(4) instructions stating that in the event of one suction outlet being completely blocked, the remaining suction outlets serving that system shall have a flow rating capable of the full flow of the pump(s) for the specific suction system

(5) maximum flow rating with head loss curve

(6) acceptable connecting pipe size(s)

(7) mounting position(s)

(8) suction outlet part number(s), and/or model number(s), and detailed field build sump design specifications, when applicable

- (9) part number/description list, and “Replace within ‘YY’ installed years” for all parts
- (10) tools required
- (11) service and winterizing instructions
- (b) a cautionary note not to exceed the maximum allowable flow rate stated on the suction fitting
- (c) a note that the suction fitting including fasteners should be observed for damage or tampering before each use of this facility
- (d) a statement that missing, broken, or cracked suction fittings shall be replaced before using this facility
- (e) a statement that loose suction fittings shall be reattached or replaced before using this facility
- (f) a statement “Read, then keep these instructions for future reference”
- (g) a cautionary note about increasing flow by increasing pump size.

Mandatory Appendix I

Torso Specimen with Rectangle Superimposed

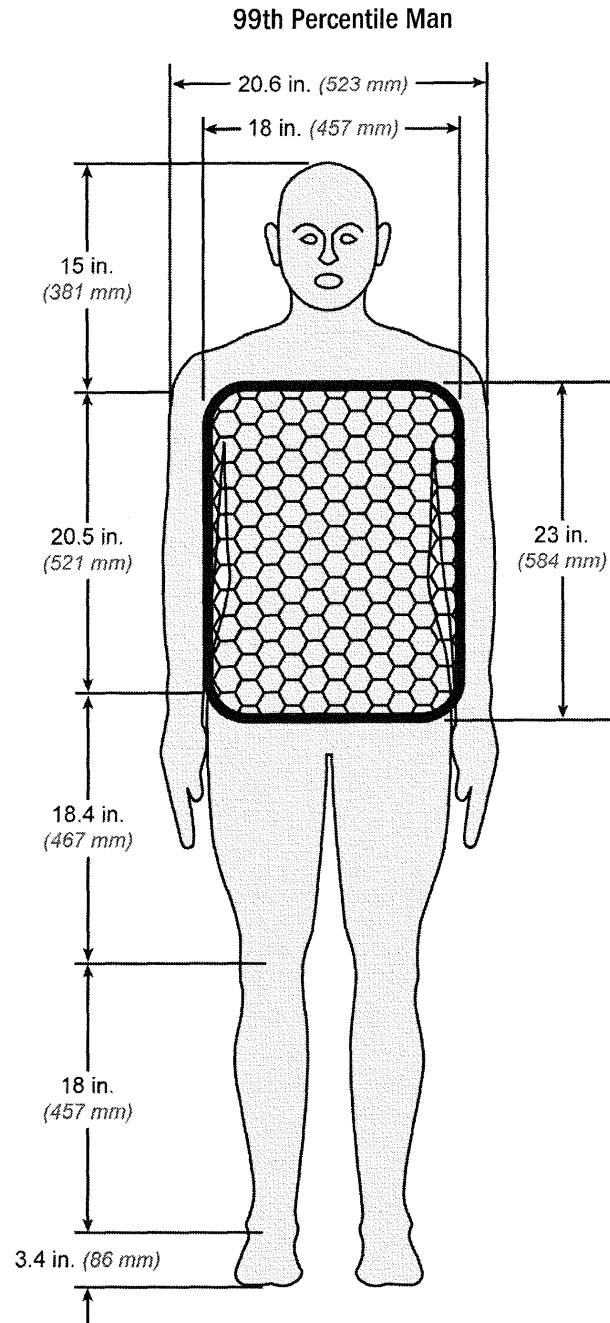

Mandatory Appendix II

Fitting Type Requirements

Table II Fitting Type Requirements					
Type	Field Fabricated Outlets	Venturi Outlets	Swim Jet Combination Outlets	Submerged Suction Outlets	Self-Contained Spa Fittings
Certification	Registered Design Professional	Independent Laboratory (1)	Independent Laboratory (1)	Independent Laboratory (1)	Independent Laboratory (1)
Single or multiple	Yes	Per manufacturer	Per manufacturer	Per manufacturer	Multiple only
Require tools to open	Yes	Yes	Yes	Yes	Yes
UV test and usable lifetime labeling	Yes	Yes	Yes	Yes	Yes
Sump/fitting specification required	Yes	Yes	Yes	Yes	Yes
Body entrapment test	Yes	Yes	Yes	Yes	Yes
Vertical load	Note 2	Yes	Yes	Yes	Yes
Horizontal load	Note 2	Yes	Yes	Yes	Yes
Excess load	Note 2	Yes	Yes	Yes	Yes
Shear test	Note 2	Yes	Yes	Yes	Yes
Vacuum test	Note 2	Yes	Yes	Yes	Yes
Pull test	Note 2	Yes	Yes	Yes	Yes
Hair test	No	Yes	Yes	Yes	Yes
Finger test	Note 2	Yes	Yes	Yes	Yes

NOTES:

- (1) All testing and any certification of this fitting shall be in accordance with ISO/IEC 17025.
 (2) Design shall be per Registered Design Professional.

ANSI/APSP-16 2011



**American National Standard for
Suction Fittings for Use in
Swimming Pools, Wading Pools, Spas, and Hot Tubs**

Familiarity with the ANSI/APSP standards is essential for anyone who builds, manufactures, sells, or services pools, spas or hot tubs.

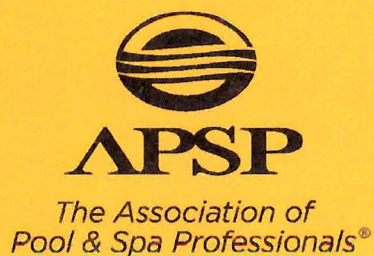

2111 Eisenhower Avenue
Alexandria VA 22314-4695

703.838.0083
memberservices@APSP.org
APSP.org

Non-mandatory Appendix A

Suction Fitting Test Form–Hair Entrapment

Suction Fitting Test Form–Hair Entrapment													
Date:			Pump Type:				Water Temp:						
Operator:			Hair Type:				Maximum Flow (gpm) ¹						
Protocol:			Fitting Description:				Maximum Vacuum (in Hg) ²						
F _i ³ (gpm)	V _i ⁴ (in Hg)		1	2	3	4	5	6	7	8	9	10	Comments ⁷
		F _f ⁵ (gpm) V _f ⁶ (in Hg) Pull (lbf)											
		F _f V _f Pull											
		F _f V _f Pull											
		F _f V _f Pull											
		F _f V _f Pull											
		F _f V _f Pull											
		F _f V _f Pull											

NOTES:

- (1) Maximum Flow (gpm) shall be the flow rate measurement in gallons per minute with the fitting in place with all valves fully open.
- (2) Maximum Vacuum (in Hg) shall be the vacuum recorded in inches of mercury as measured at maximum flow.
- (3) F_i shall mean the initial flow rate in gallons per minute, which is measured before the entanglement effort is started.
- (4) V_i shall mean the initial vacuum as measured in inches of mercury before the entanglement effort is started.
- (5) F_f shall mean the final flow rate as measured prior to removal of the hair.
- (6) V_f shall mean the final vacuum as measured prior to removal of the hair.
- (7) Report any significant changes here.

(Approved by the American National Standards Institute February 17, 2011)