

Two models offer higher design load values and optional installation with the SDS Strong-Drive screw.

MATERIAL: 3 gauge. **FINISH:** Simpson gray paint.

INSTALLATION: • Use all specified fasteners. See General Notes.

- All multiple members must be fastened together to act as a single unit.
- Maximum 1 1/8" bottom chord in the carrying member to allow for the minimum bolt end distance.
- See page 13 for SDS screws.
- For optional installations see page 164.

CODES: See page 10 for Code Listing Key Chart.

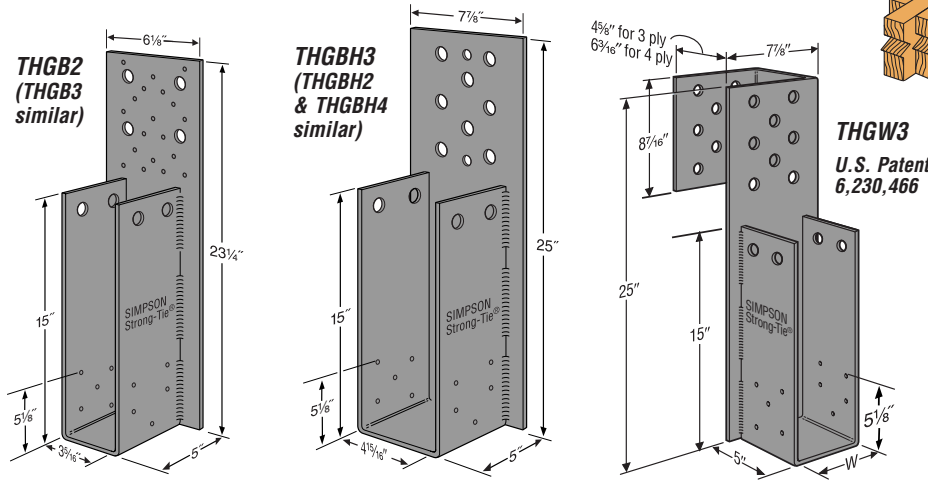
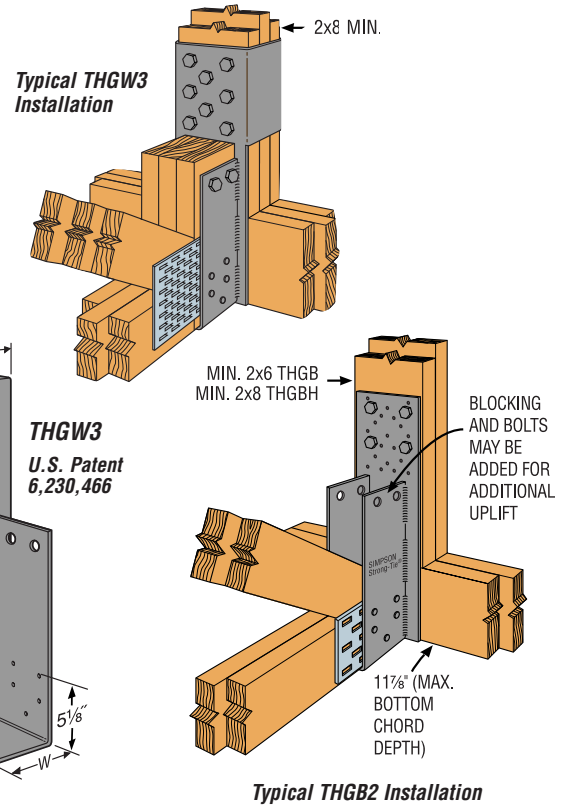

Model No.	Width (W)	Fasteners		Length of Fastener in Carrying Member	Doug-Fir/So. Pine Allowable Loads					Spruce-Pine-Fir Allowable Loads					Code Ref.					
		Carried Member	Carrying Member		Uplift ¹ (133/160)	Floor (100)	Snow (115)	Roof (125)	Wind (133)	Uplift ¹ (133/160)	Floor (100)	Snow (115)	Roof (125)	Wind (133)						
THGB2	3 5/8	10-10d & 2-3/4" MB	4-3/4" MB	3	7540	5655	6505	7070	7540	6400	4800	5520	6000	6400	160					
				4 1/2	8010	6235	7170	7795	8315							6650	5775	6640	7220	7235
				6	8010	6235	7170	7795	8315											
THGB2	3 5/8	10-10d & 2-3/4" MB	19-SDS 1/2 X 3 ²	3	8010	6385	7340	7980	8510	6650	5550	6380	6935	7200						
				4 1/2		6385	7340	7980	8510		5550	6380	6935	7200						
				6		6385	7340	7980	8510		5550	6380	6935	7200						
THGBH2	3 5/8	10-10d & 2-3/4" MB	8-3/4" MB	3	8010	10010	10010	10010	10010	6650	7745	7950	8090	8200						
				4 1/2		10010	10010	10010	10010		7745	7950	8090	8200						
				6		10010	10010	10010	10010		7745	7950	8090	8200						
THGB3	4 5/8	10-10d & 2-3/4" MB	4-3/4" MB	3	7540	5655	6505	7070	7540	6400	4800	5520	6000	6400						
				4 1/2	8010	6235	7170	7795	8315							6650	5775	6640	7220	7235
				6	8010	6230	7165	7795	8315											
THGB3	4 5/8	10-10d & 2-3/4" MB	19-SDS 1/2 X 3 ²	3	8010	6385	7340	7980	8510	6650	5550	6380	6935	7200						
				4 1/2		6385	7340	7980	8510		5550	6380	6935	7200						
				6		6385	7340	7980	8510		5550	6380	6935	7200						
THGBH3	4 5/8	10-10d & 2-3/4" MB	8-3/4" MB	3	8010	10010	10010	10010	10010	6650	8310	8310	8310	8310						
				4 1/2		12000	12000	12000	12000		9960	9960	9960	9960						
				6		12335	12335	12335	12335		10240	10240	10240	10240						
THGBH4	6 3/8	10-10d & 2-3/4" MB	4-3/4" MB ³	3	7540	5655	6505	7070	7540	6400	4800	5520	6000	6400						
				4 1/2	8010	6235	7170	7795	8315						6650	5775	6640	7220	7235	
				6	8010	6235	7170	7795	8315											6650
THGBH4	6 3/8	10-10d & 2-3/4" MB	6-3/4" MB ³	3	8010	8410	9565	9565	9565	6650	7135	7940	7940	7940						
				4 1/2		9310	9565	9565	9565		7940	7940	7940	7940						
				6		9280	9565	9565	9565		7940	7940	7940	7940						
THGBH4	6 3/8	10-10d & 2-3/4" MB	8-3/4" MB	3	8010	10010	10010	10010	10010	6650	8310	8310	8310	8310						
				4 1/2		12425	14050	14050	14050		11510	11660	11660	11660						
				6		12425	14050	14050	14050		11510	11660	11660	11660						
THGW3-3 ⁴	4 5/8	10-10d & 2-3/4" MB	8-3/4" MB	4 1/2	8010	21830	21830	21830	21830	6650	18120	18120	18120	18120						
6				21830		21830	21830	21830	18120		18120	18120	18120							
THGW4-3 ⁴	6 3/8	10-10d & 2-3/4" MB	8-3/4" MB	4 1/2	8010	24165	24165	24165	24165	6650	20055	20055	20055	20055						
6				24165		24165	24165	24165	20055		20055	20055	20055							

1. Allowable loads have been increased 33% and 60% for earthquake or wind loading with no further increase allowed; reduce where other loads govern. A 2 ply minimum truss is required. When using 10-10d nails only for carried member, uplift is 1960 lbs for Doug-Fir/So. Pine and 1625 lbs for Spruce-Pine-Fir.
2. SDS 1/2 X 3 must have a minimum 2 ply member.
3. Bolts must be installed symmetrically when using less than 8 bolts on the 8-bolt backplate.
4. Loads for THGW models are based on end grain bearing.
5. Minimum fasteners 10-10d will achieve the down loads and the corresponding uplift (see footnote 1). To achieve maximum uplift, install nails and bolts listed in the table.
6. Wind (133) is a download rating.