

**TABLE S601.7 - UPLIFT CONNECTIONS - 150 MPH WINDS EXP "C"**  
NFCM 2015 TABLE 3.2C

CONNECTION	FRAMING SPACING (INCHES)	ROOF SPAN (FEET)	UPLIFT	LATERAL	SHEAR	NUMBER OF 8d COMMON NAILS OR 10d BOX NAILS IN EACH END OF 1-1/4"X20 GAGE STRAP
ROOF ASSEMBLY TO WALL ASSEMBLY	16" OC	16	40T	292	152R	4
WALL ASSEMBLY TO FOUNDATION	16" OC	16	224	219	436	4

**TABLE S601.8 - SILL OR BOTTOM PLATE TO FOUNDATION CONNECTIONS RESISTING UPLIFT LOADS - 150 MPH WIND EXP "C"**  
NFCM 2015 TABLE 3.2C

BOTTOM PLATE TO FOUNDATION ANCHOR BOLT CONNECTION RESISTING	FOUNDATION SUPPORTING	MAXIMUM ANCHOR BOLT SPACING (INCHES)
UPLIFT LOADS	1 - 3 STORIES	8" END ZONES 25 INCHES ON CENTER 30 INCHES ON CENTER

NOTE: A MINIMUM OF ONE ANCHOR BOLT SHALL BE PROVIDED WITHIN 6 TO 12 INCHES OF EACH END OF EACH PLATE

**TABLE S601.9 - SILL OR BOTTOM PLATE TO FOUNDATION CONNECTIONS RESISTING SHEAR LOADS - 150 MPH WIND EXP "C"**  
NFCM 2015 TABLE 3.2B

BOTTOM PLATE TO FOUNDATION ANCHOR BOLT CONNECTION RESISTING	FOUNDATION SUPPORTING	MAXIMUM ANCHOR BOLT SPACING (INCHES)
UPLIFT LOADS	4 STORY	5/8" Ø ANCHOR BOLTS 48 INCHES ON CENTER W/3X3X1/4" WASHER

**TABLE S601.10 - FULL HEIGHT STUD REQUIREMENT FOR HEADERS OR WINDOW SILL PLATES IN EXTERIOR WALLS EXPOSURE "C"**  
NFCM 2015 TABLE 3.23C

HEADER SPAN (FEET)	WALL SPACING (INCHES)		
	12" O.C.	16" O.C.	24" O.C.
2	1	1	1
4	2	2	1
6	3	3	2
8	4	3	2

**TABLE S601.5 - JACK STUD REQ - INT LOADBEARING WALLS**

HEADER SUPPORTING	HEADER SPAN (FT)	ROOF SPAN (FEET)													
		12 FEET				24 FEET				36 FEET					
		3"	4.5"	5"	6.5"	3"	4.5"	5"	6.5"	3"	4.5"	5"	6"		
ONE FLOOR ONLY (CENTER BEARING)	2	1	1	1	1	1	1	1	1	1	1	1	1	1	1
	4	1	1	1	1	1	1	1	1	1	1	1	1	1	1
	6	1	1	1	1	1	1	1	1	2	1	1	1	1	1
	8	1	1	1	1	2	1	1	1	2	2	2	1	1	1
	10	1	1	1	1	2	2	1	1	3	2	2	2	2	1
	12	1	1	1	1	2	2	2	1	3	2	2	2	2	2
	14	2	1	1	1	3	2	2	2	4	3	3	2	2	2
	16	2	2	1	1	3	2	2	2	4	3	3	2	2	2
	2	1	1	1	1	1	1	1	1	2	1	1	1	1	1
	4	1	1	1	1	2	1	1	1	3	2	2	2	2	2
6	2	1	1	1	3	2	2	2	4	3	2	2	2	2	
8	2	2	1	1	3	2	2	2	5	3	3	3	3	3	
10	2	2	2	1	4	3	3	2	6	4	4	3	3	3	
12	3	2	2	2	5	3	3	3	7	5	4	4	4	4	
14	3	2	2	2	6	4	4	3	8	5	5	4	4	4	
16	4	3	2	2	6	4	4	3	9	6	6	5	5	5	

**TABLE S601.6 - JACK STUD REQ - EXTERIOR LOADBEARING WALLS**  
NFCM 2015 TABLE 3.22F

HEADER WIDTH - 3" (2-2X), 4.5" (3-2X), 5", 6.5" (4-2X) EACH W/ 1/2" PLYWOOD SPACER BETWEEN	ROOF LIVE LOAD 20 PSF				ROOF LIVE LOAD 30 PSF				
	3"	4.5"	5"	6.5"	3"	4.5"	5"	6.5"	
	NUMBER OF JACK STUDS REQUIRED								
ROOF AND CEILING	2	1	1	1	1	1	1	1	1
	4	1	1	1	1	1	1	1	1
	6	2	1	1	1	2	1	1	1
	8	2	2	2	1	2	2	2	1
	10	3	2	2	2	3	2	2	2
	12	3	2	2	2	3	2	2	2
	14	4	3	2	2	4	3	2	2
	16	4	3	3	2	4	3	3	2
	2	1	1	1	1	1	1	1	1
	4	2	1	1	1	2	1	1	1
6	2	2	2	1	3	2	2	2	
8	3	2	2	2	3	2	2	2	
10	4	3	2	2	4	3	3	2	
12	4	3	3	2	5	3	3	3	
14	5	4	3	3	5	4	3	3	
16	6	4	4	3	6	4	4	3	

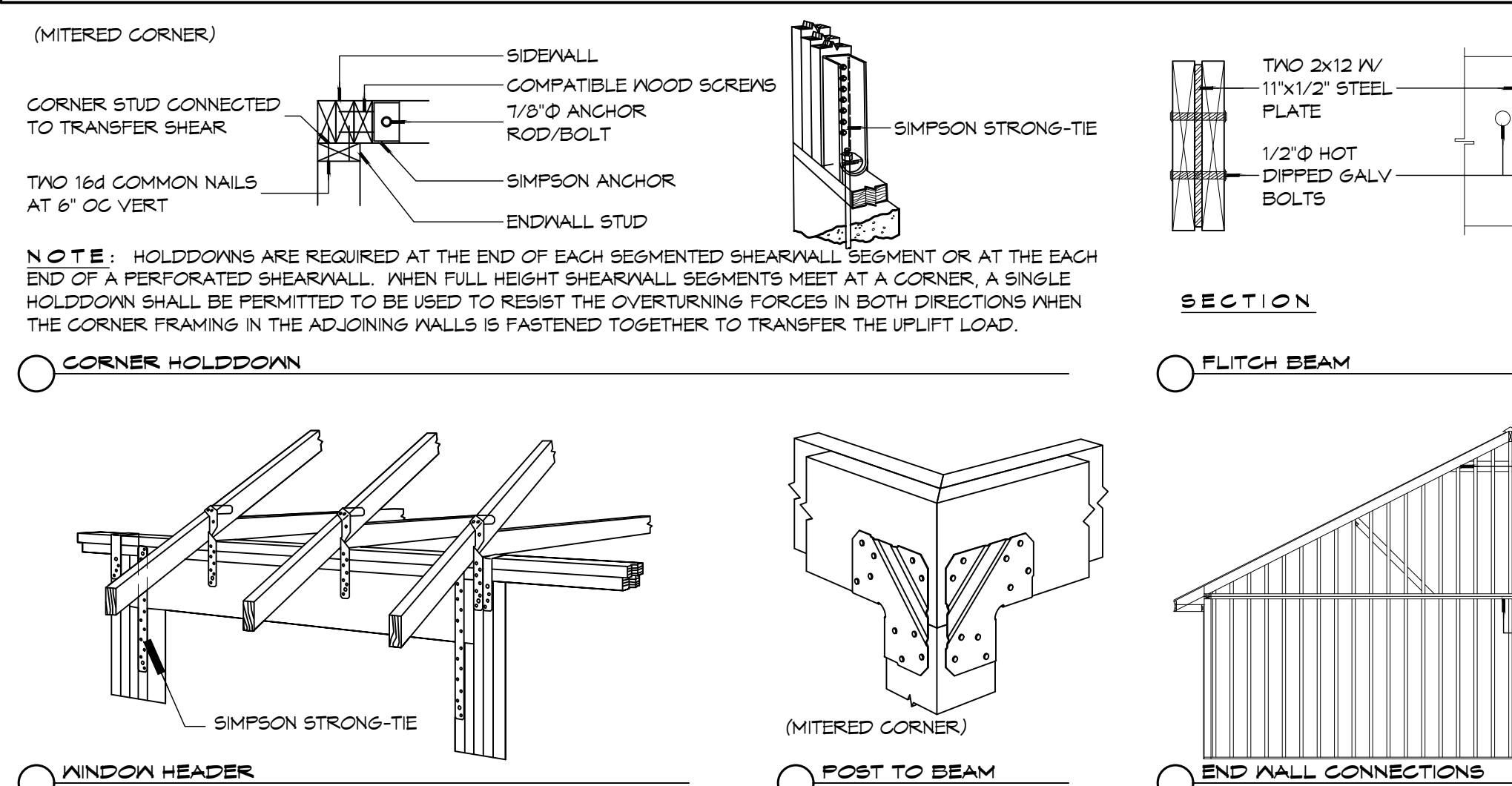

**TABLE S601.3 - NAILING SCHEDULE**  
NFCM 2015 TABLE 3.1

DESCRIPTION	NUMBER OF COMMON NAILS	NUMBER OF BOX NAILS	SPACING
HEADER TO HEADER (FACE NAILED)	16d	16d	16" OC EDGES

**TABLE S601.4 - BUILDING ENVELOPE REQUIREMENTS**

ROOFS	OPAQUE ELEMENTS	ASSEMBLY MAXIMUM	INSULATION MIN. R-VALUE
METAL BUILDING	INSULATION ENTIRELY ABOVE DECK	U-0.048	R-20.0 c.i.
METAL BUILDING	METAL BUILDING	U-0.085	R-19
METAL BUILDING	ATTIC AND OTHER	U-0.021	R-38
STEEL-FRAMED	MASS	U-0.151	R-5.7 c.i.
WOOD-FRAMED AND OTHER	METAL BUILDING	U-0.113	R-13.0
MASS	STEEL-FRAMED	U-0.124	R-13.0
STEEL JOIST	WOOD-FRAMED AND OTHER	U-0.084	R-13.0
WOOD FRAMED AND OTHER	MASS	U-0.101	R6-9 c.i.
UN-HEATED	STEEL JOIST	U-0.052	R-19.0
SNOWING	WOOD FRAMED AND OTHER	U-0.051	R-19.0
NON-SNOWING	UN-HEATED	F-0.130	NR
	SNOWING	U-0.100	NR
	NON-SNOWING	U-1.450	NR

**ROOF UNDERLAYMENT NOTES**

- FOR ROOF SLOPES FROM TWO UNITS VERTICAL IN 12 UNITS HORIZONTAL (17-PERCENT SLOPE), UP TO FOUR UNITS VERTICAL IN 12 UNITS HORIZONTAL (33-PERCENT SLOPE), UNDERLAYMENT SHALL BE TWO LAYERS APPLIED IN THE FOLLOWING MANNER:
  - APPLY A 14 INCH STRIP OF UNDERLAYMENT FELT PARALLEL WITH AND STARTING AT THE EAVES, FASTENED SUFFICIENTLY TO HOLD IN PLACE. STARTING AT THE EAVE, APPLY 36 INCH WIDE SHEETS OF UNDERLAYMENT, OVERLAPPING SUCCESSIVE SHEETS 14 INCHES, AND FASTENED SUFFICIENTLY TO HOLD IN PLACE.
- FOR ROOF SLOPES OF FOUR UNITS VERTICAL IN 12 UNITS HORIZONTAL (33-PERCENT SLOPE) OR GREATER, UNDERLAYMENT SHALL BE ONE LAYER APPLIED IN THE FOLLOWING MANNER:
  - UNDERLAYMENT SHALL BE APPLIED SHINGLE FASHION, PARALLEL TO AND STARTING FROM THE EAVE AND LAPPED 2 INCHES, FASTENED SUFFICIENTLY TO HOLD IN PLACE. END LAPS SHALL BE OFFSET BY 6 FEET.

**SHINGLE APPLICATION & FASTENING NOTES**

- ASPHALT STRIP SHINGLES SHALL HAVE A MINIMUM OF SIX FASTENERS PER SHINGLE WHERE THE ROOF IS IN ONE OF THE FOLLOWING CATEGORIES:
  - THE BASIC WIND SPEED IS 110 MPH OR GREATER AND THE EAVE IS 20 FEET OR HIGHER ABOVE GRADE.
  - THE BASIC WIND SPEED IS 120 MPH OR GREATER.
  - SPECIAL WIND ZONES.

**METAL ROOF APPLICATION & FASTENING NOTES**

- INSTALL METAL ROOF PER MANUFACTURER'S RECOMMENDATIONS FOR 150MPH WIND SPEED.

**GENERAL UPLIFT CONNECTION NOTES**

**ROOF ASSEMBLY TO WALL ASSEMBLY:** UPLIFT CONNECTIONS SHALL BE FROM RAFTER OR TRUSS TO WALL STUD. WHEN RAFTERS OR TRUSSES ARE NOT LOCATED DIRECTLY ABOVE STUDS, RAFTERS SHALL BE ATTACHED TO THE WALL PLATE AND THE WALL TOP PLATE SHALL BE ATTACHED TO THE WALL STUD WITH UPLIFT CONNECTIONS. UPLIFT CONNECTIONS SHALL BE IN ACCORDANCE WITH TABLE S601.10.

**WALL ASSEMBLY TO WALL ASSEMBLY:** STORY TO STORY UPLIFT CONNECTIONS FROM UPPER STORY WALL STUD TO LOWER STORY WALL STUD. WHEN UPPER STORY WALL STUDS ARE NOT LOCATED DIRECTLY ABOVE LOWER WALL STUDS, THE STUDS SHALL BE ATTACHED TO A COMMON MEMBER IN THE FLOOR ASSEMBLY BY UPLIFT CONNECTIONS. UPLIFT CONNECTIONS SHALL BE IN ACCORDANCE WITH TABLE S601.11.

**WALL ASSEMBLY TO FOUNDATION:** FIRST FLOOR WALL STUDS SHALL BE CONNECTED TO THE FOUNDATION, SILL PLATE, OR BOTTOM PLATE. A MINIMUM OF A 1-1/4" X 20 GA. ASTM A653 GRADE 33 STEEL STRAP SHALL BE NAILED TO THE WALL STUDS AND HAVE A MINIMUM EMBEDMENT OF 1 INCHES IN CONCRETE FOUNDATIONS AND SLABS-ON-GRADE, 15 INCHES IN MASONRY BLOCK FOUNDATIONS, OR BE LAPPED UNDER THE BOTTOM PLATE. 3 INCH SQUARE WASHERS SHALL BE USED ON THE ANCHOR BOLTS AND ANCHOR BOLT SPACINGS SHALL NOT EXCEED THE REQUIREMENTS. STEEL STRAPS EMBEDDED IN OR IN CONTACT WITH SLAB-ON-GRADE OR MASONRY BLOCK FOUNDATIONS SHALL BE HOT-DIPPED GALV. AFTER FABRICATION, OR MANUF. FROM 5185 OR 2450 GALV. STL. CONNECTIONS SHALL BE IN ACCORDANCE WITH TABLE S601.12.

**TABLE S601.1 - ROOF SHEATHING ATTACHMENT REQUIREMENT - WIND LOAD EXP "C"**

SHEATHING LOCATION	RAFTER / TRUSS SPACING	E F	
		MAX NAIL SPACING FOR 8d COMMON NAILS OR 10d BOX NAILS (INCHES OC)	
INTERIOR ZONE	12" OC	6	12
	16" OC	6	12
	24" OC	6	12
PERIMETER EDGE ZONE	12" OC	6	6
	16" OC	4	4
	24" OC	3	3

150 MPH WIND - EXPOSURE "C" TYPICAL  
E = NAIL SPACING AT PANEL EDGES, INCHES.  
F = NAIL SPACING AT INTERMEDIATE SUPPORTS IN THE PANEL FIELD, INCHES.

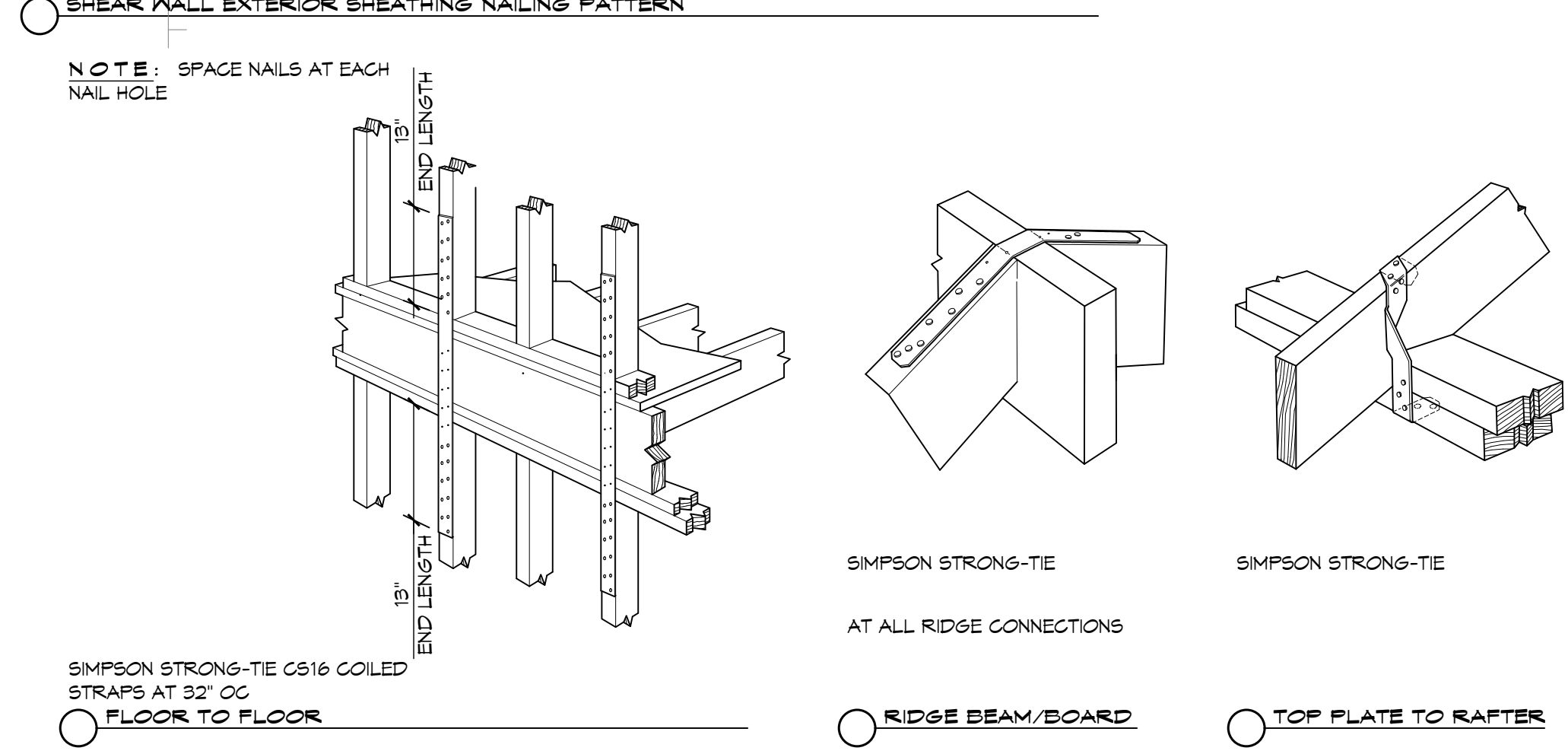
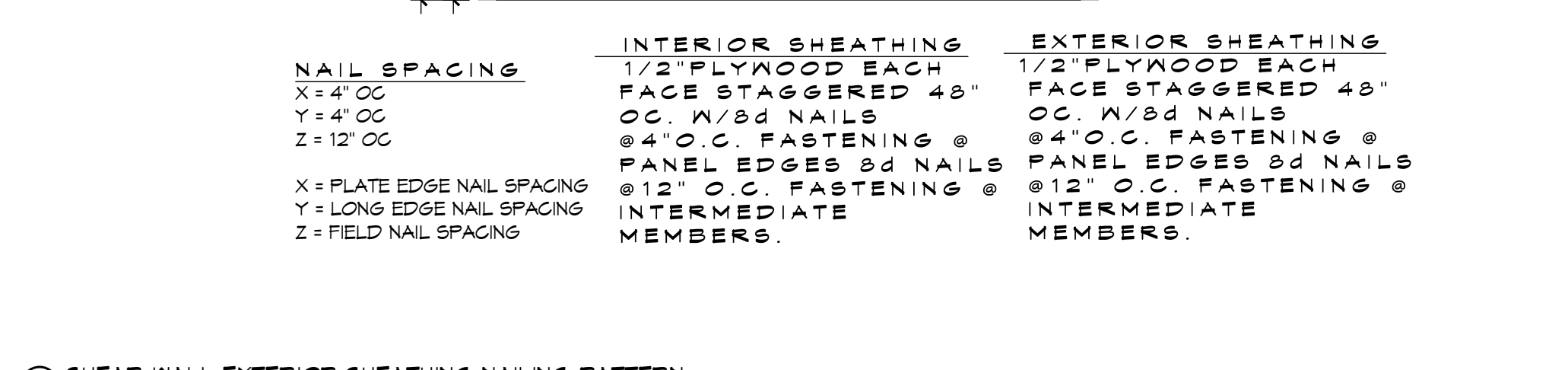
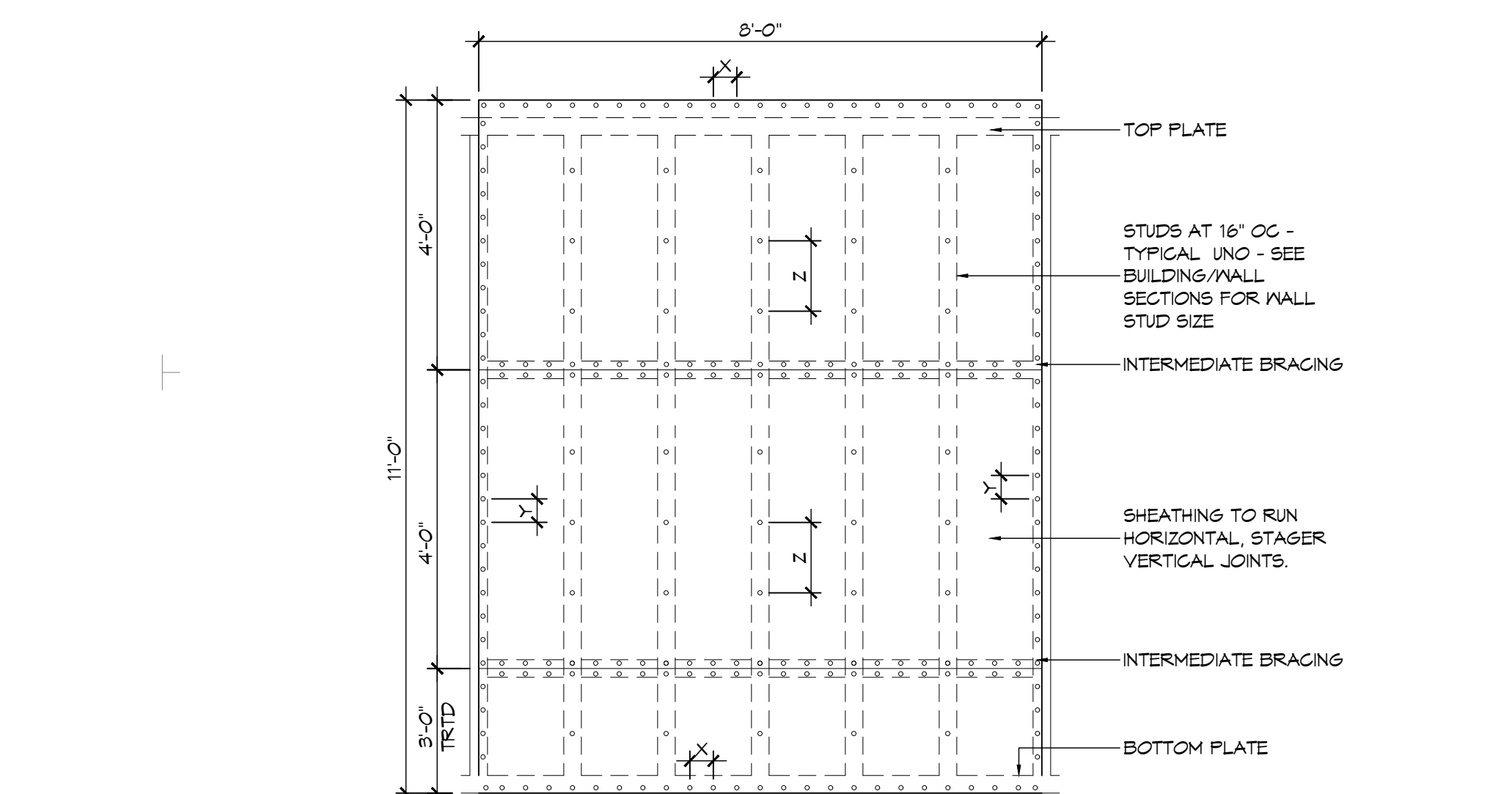
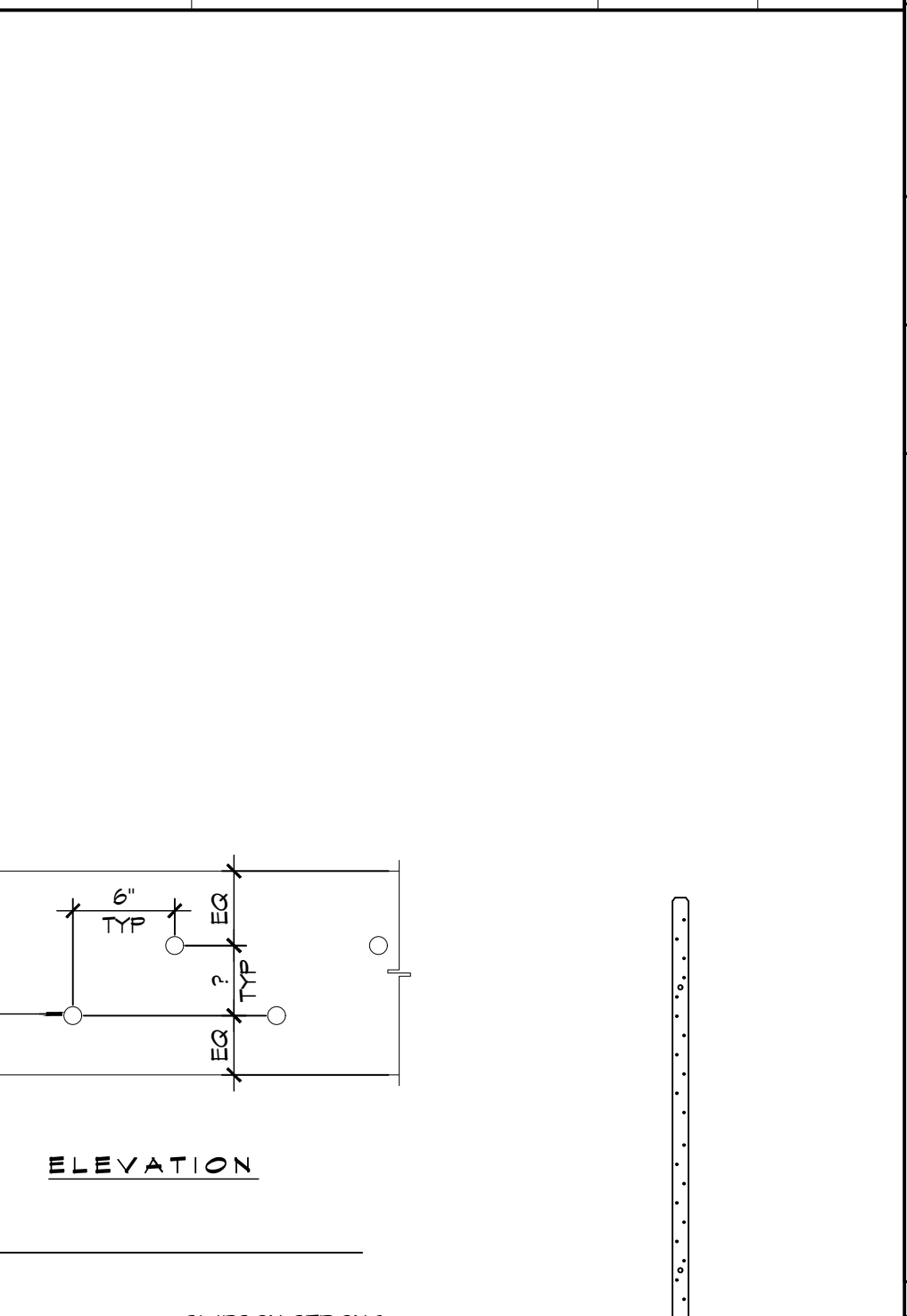

**TABLE S601.1 - WALL SHEATHING AND CLADDING REQUIREMENT - WIND LOAD EXP "C"**

SHEATHING LOCATION	RAFTER / TRUSS SPACING	E F	
		MAX NAIL SPACING FOR 8d COMMON NAILS OR 10d BOX NAILS (INCHES OC)	
INTERIOR ZONE	12" OC	6	12
	16" OC	6	12
	24" OC	6	12
PERIMETER EDGE ZONE	12" OC	6	6
	16" OC	4	4
	24" OC	3	3

150 MPH WIND - EXPOSURE "C" TYPICAL  
E = NAIL SPACING AT PANEL EDGES, INCHES.  
F = NAIL SPACING AT INTERMEDIATE SUPPORTS IN THE PANEL FIELD, INCHES.

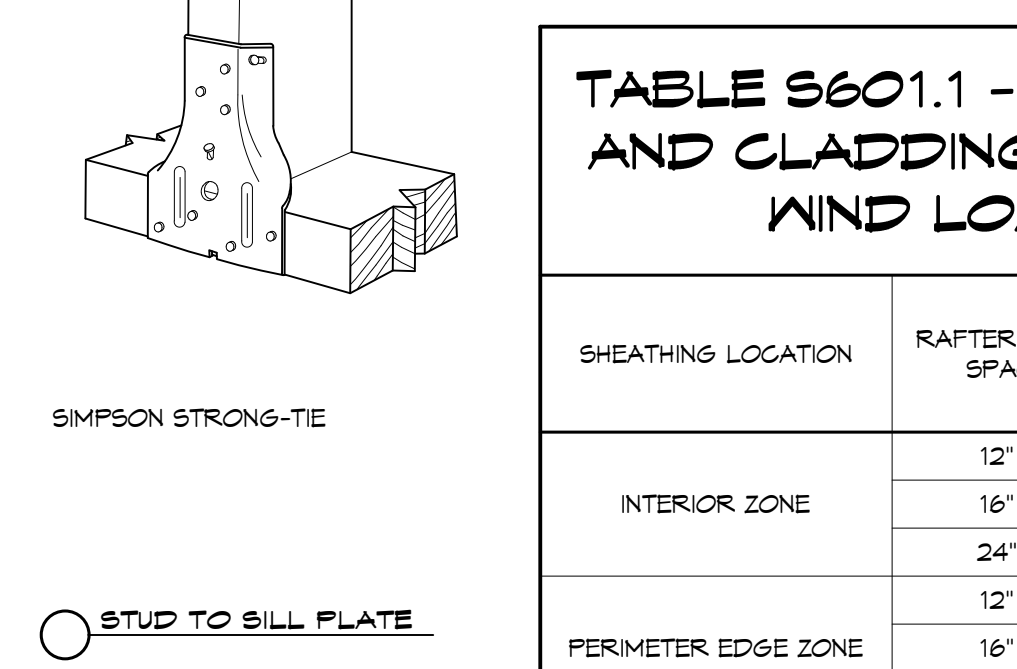

**TABLE S601.1 - ROOF SHEATHING ATTACHMENT REQUIREMENT - WIND LOAD EXP "C"**

SHEATHING LOCATION	RAFTER / TRUSS SPACING	E F	
		MAX NAIL SPACING FOR 8d COMMON NAILS OR 10d BOX NAILS (INCHES OC)	
INTERIOR ZONE	12" OC	6	12
	16" OC	6	12
	24" OC	6	12
PERIMETER EDGE ZONE	12" OC	6	6
	16" OC	4	4
	24" OC	3	3

150 MPH WIND - EXPOSURE "C" TYPICAL  
E = NAIL SPACING AT PANEL EDGES, INCHES.  
F = NAIL SPACING AT INTERMEDIATE SUPPORTS IN THE PANEL FIELD, INCHES.

**TABLE S601.1 - WALL SHEATHING AND CLADDING REQUIREMENT - WIND LOAD EXP "C"**

SHEATHING LOCATION	RAFTER / TRUSS SPACING	E F	
		MAX NAIL SPACING FOR 8d COMMON NAILS OR 10d BOX NAILS (INCHES OC)	
INTERIOR ZONE	12" OC	6	12
	16" OC	6	12
	24" OC	6	12
PERIMETER EDGE ZONE	12" OC	6	6
	16" OC	4	4
	24" OC	3	3

150 MPH WIND - EXPOSURE "C" TYPICAL  
E = NAIL SPACING AT PANEL EDGES, INCHES.  
F = NAIL SPACING AT INTERMEDIATE SUPPORTS IN THE PANEL FIELD, INCHES.

**TYPICAL CONNECTION DETAILS**  
SCALE: NTS

**TABLE S601.1 - WALL SHEATHING AND CLADDING REQUIREMENT - WIND LOAD EXP "C"**

SHEATHING LOCATION	RAFTER / TRUSS SPACING	E F	
		MAX NAIL SPACING FOR 8d COMMON NAILS OR 10d BOX NAILS (INCHES OC)	
INTERIOR ZONE	12" OC	6	12
	16" OC	6	12
	24" OC	6	12
PERIMETER EDGE ZONE	12" OC	6	6
	16" OC	4	4
	24" OC	3	3

150 MPH WIND - EXPOSURE "C" TYPICAL  
E = NAIL SPACING AT PANEL EDGES, INCHES.  
F = NAIL SPACING AT INTERMEDIATE SUPPORTS IN THE PANEL FIELD, INCHES.

**DAMMON ENGINEERING & MISSISSIPPI**  
1500 PLAZA DRIVE, SUITE 200  
NEW ORLEANS, LOUISIANA 70130  
PH: 504.585.5532

**THE SIXTH BAPTIST CHURCH**  
RENOVATION AND ADDITION  
928 FELICITY STREET  
NEW ORLEANS, LOUISIANA 70130

**PROJECT NO:** 22201  
**DATE:**  
**BY:**  
**CHECKED:**

**PROGRESS PRINT**  
NOT FOR CONSTRUCTION

**FULL RELEASE**  
THIS DRAWING IS FULLY RELEASED BY THE ARCHITECT FOR CONSTRUCTION OF THIS PROJECT ONLY

NOT TO BE COPIED OR REPRODUCED WITHOUT EXPRESSED WRITTEN CONSENT OF HEWITT-WASHINGTON & ASSOCIATES

**SHEET TITLE**  
TYPICAL CONNECTION DETAILS, SCHEDULES, AND NOTES

**SHEET NO.**

**S105**  
SHEET OF

**HEWITT WASHINGTON & ASSOCIATES**  
ARCHITECTS PLANNERS & PROFESSIONAL CORPORATION  
1500 PLAZA DRIVE, SUITE 200  
NEW ORLEANS, LOUISIANA 70130  
PH: 504.585.5532

**THE SIXTH BAPTIST CHURCH**  
RENOVATION AND ADDITION  
928 FELICITY STREET  
NEW ORLEANS, LOUISIANA 70130

**PROJECT NO:** 22201  
**DATE:**  
**BY:**  
**CHECKED:**

**PROGRESS PRINT**  
NOT FOR CONSTRUCTION

**FULL RELEASE**  
THIS DRAWING IS FULLY RELEASED BY THE ARCHITECT FOR CONSTRUCTION OF THIS PROJECT ONLY

NOT TO BE COPIED OR REPRODUCED WITHOUT EXPRESSED WRITTEN CONSENT OF HEWITT-WASHINGTON & ASSOCIATES

**SHEET TITLE**  
TYPICAL CONNECTION DETAILS, SCHEDULES, AND NOTES

**SHEET NO.**

**S105**  
SHEET OF