

1-CORNER DETAIL

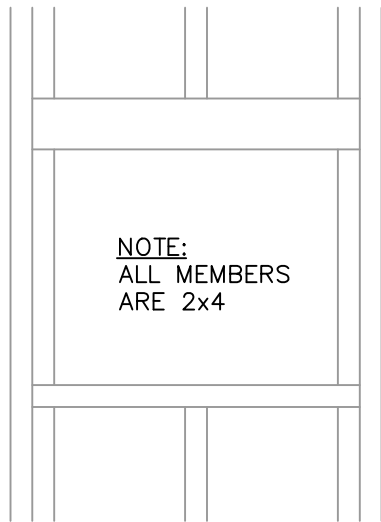

NOTE:  
ALL MEMBERS  
ARE 2x4

2-TYP WINDOW FRAMING

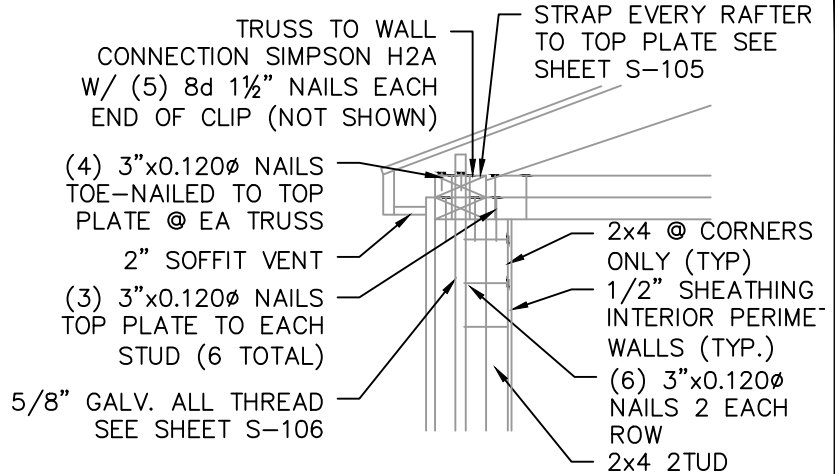

NOTE: INSTALL H2 5A PER MANUFACTURERS RECOMMENDATIONS

3-CORNER & WALL DETAIL

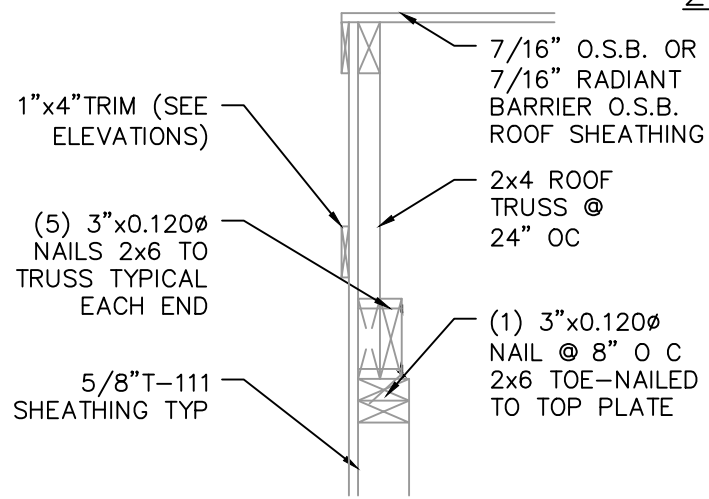

4-END WALL DETAIL

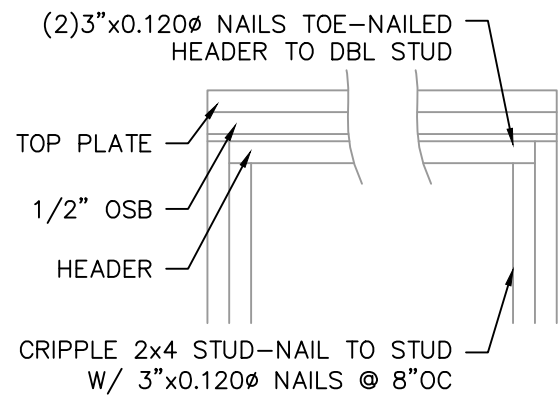

5-TYP DOOR FRAMING

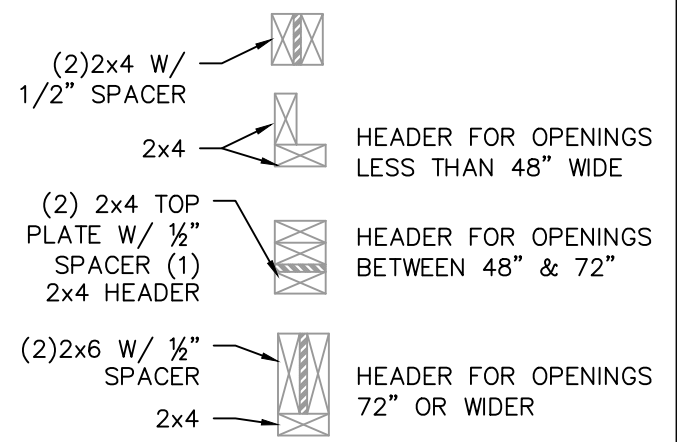

NOTE: FOR 12' HIGH OR GREATER SIDEWALLS, A 48" MAX OPENING IS ALLOWED

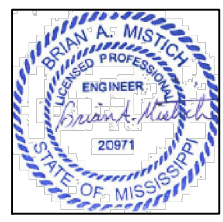

**DANCO BUILDINGS, LLC.**

PHONE: 601-551-0469 EMAIL: CHRISDANIELST6@GMAIL.COM

DRAWN BY: CKD SCALE: NTS DATE: 02-18-2026

SHEET TITLE: BUILD DETAIL 1

DRAWING NUMBER: S-109



**DAMMON ENGINEERING, INC.**

554 Old Spanish Trail Slidell, LA 70468 (985) 649-5832

Chief Engineer: Brian Mistich, PE  
554 Old Spanish Trail  
Slidell, LA 70458

www.dammonengineering.com  
info@dammonengineering.com  
PHONE: 985-649-5832