

1-CORNER DETAIL

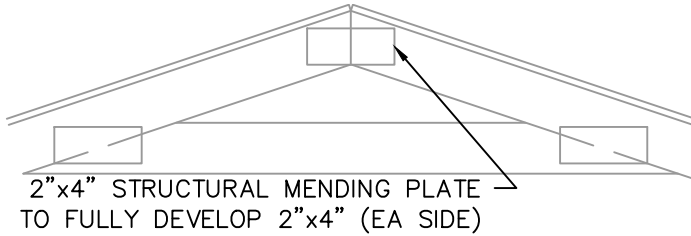

2-TRUSS SPLICE DETAIL

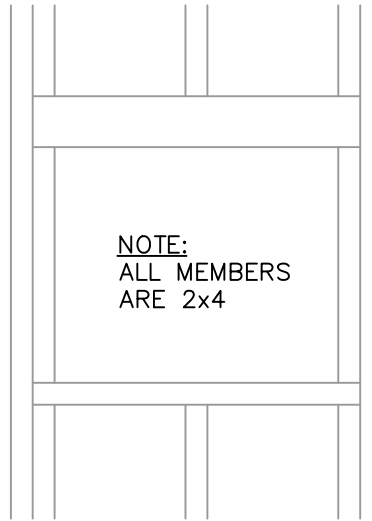

3-TYP WINDOW FRAMING

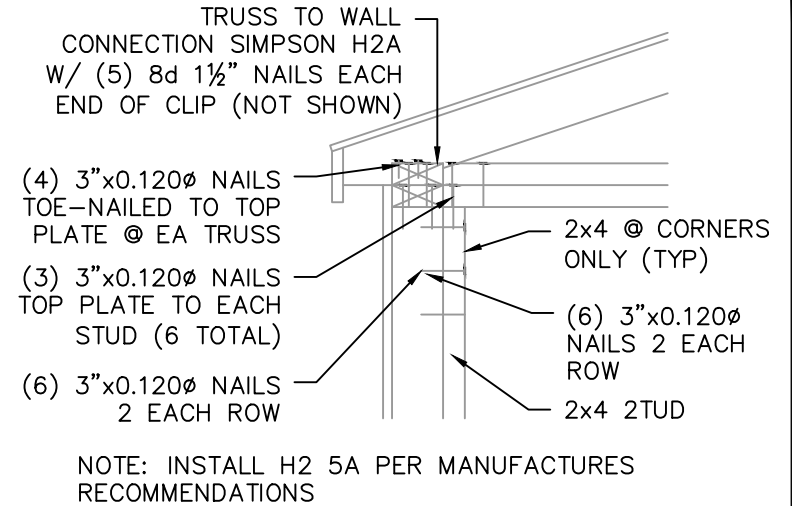

4-CORNER & WALL DETAIL

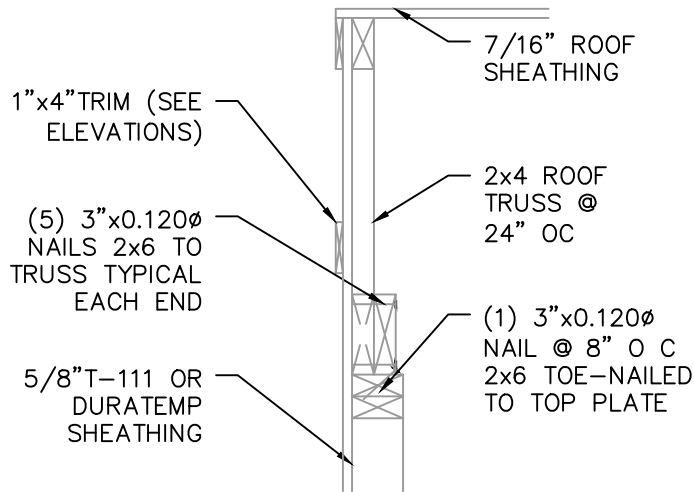

5-END WALL DETAIL

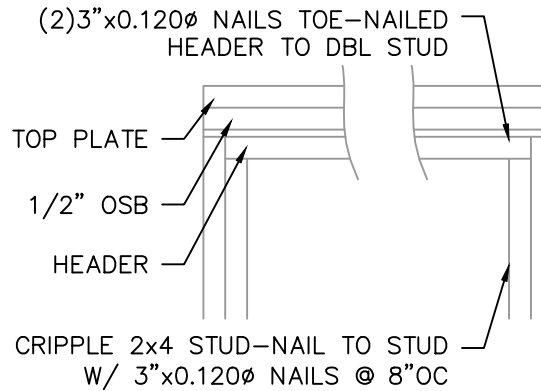

6-TYP DOOR FRAMING

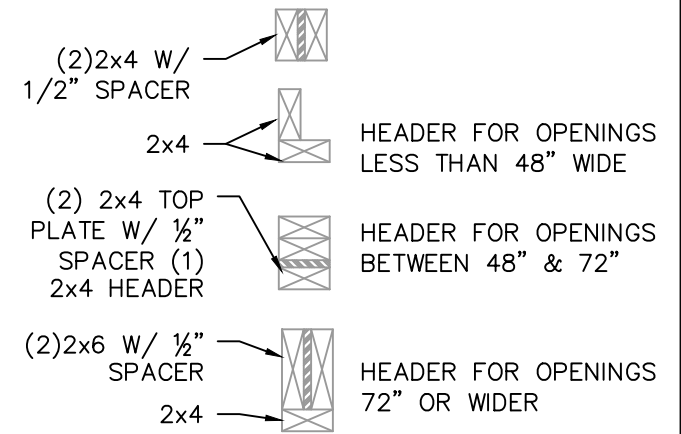

NOTE: FOR 12' HIGH OR GREATER SIDEWALLS, A 48" MAX OPENING IS ALLOWED

**APEX BUILDERS AND ASSOCIATES**  
BUILDERS & ASSOCIATES  
 504-858-6544

DRAWN BY: TNT    SCALE: NTS    DATE: 01-31-2022

SHEET TITLE: BUILD DETAIL 1

DRAWING NUMBER:

**S-109**

UTILITY-LA-V=150MPH-IBC2015

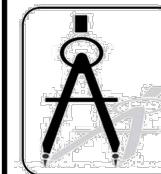

**DAMMON**  
 ENGINEERING, INC.

554 Old Spanish Trail Slidell, LA 70458 (985) 649-5832

Chief Engineer: Brian Mistich, PE  
 554 Old Spanish Trail  
 Slidell, LA 70458

www.dammonengineering.com  
 info@dammonengineering.com  
 PHONE: 985-649-5832