

1-CORNER DETAIL

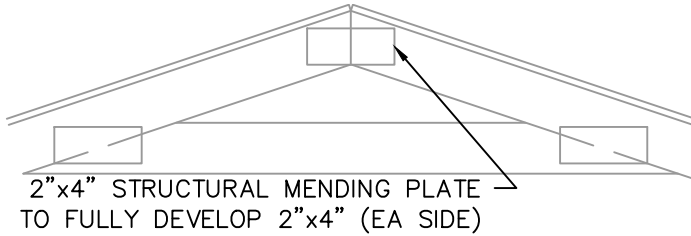

2-TRUSS SPLICE DETAIL

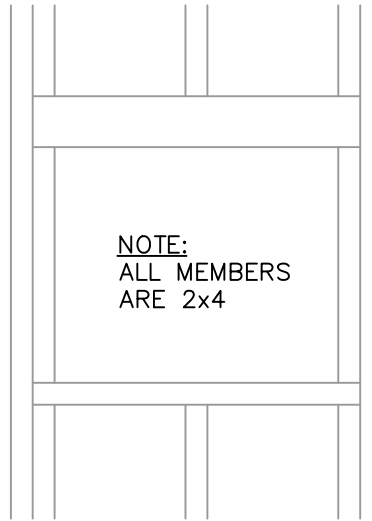

NOTE:
ALL MEMBERS
ARE 2x4

3-TYP WINDOW FRAMING

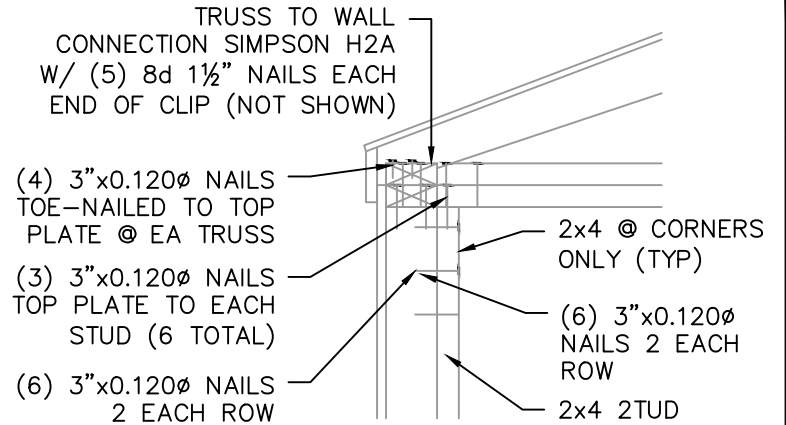

NOTE: INSTALL H2 5A PER MANUFACTURERS
RECOMMENDATIONS

4-CORNER & WALL DETAIL

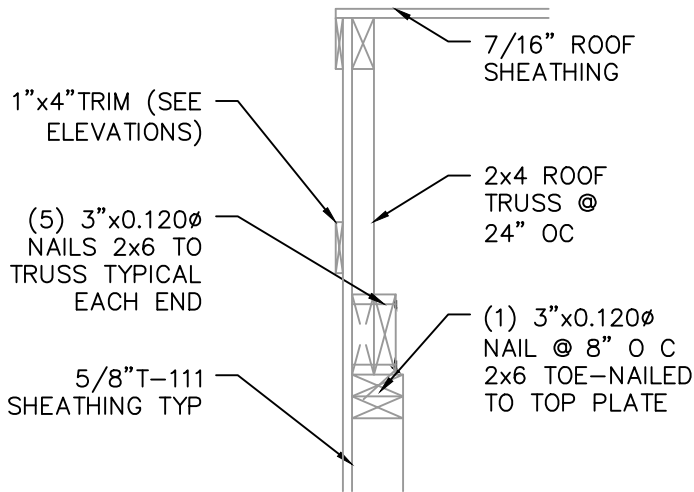

5-END WALL DETAIL

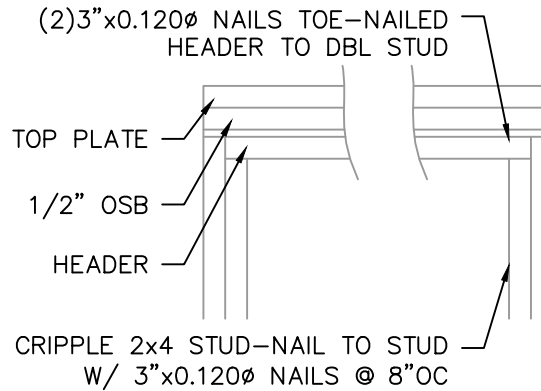

6-TYP DOOR FRAMING

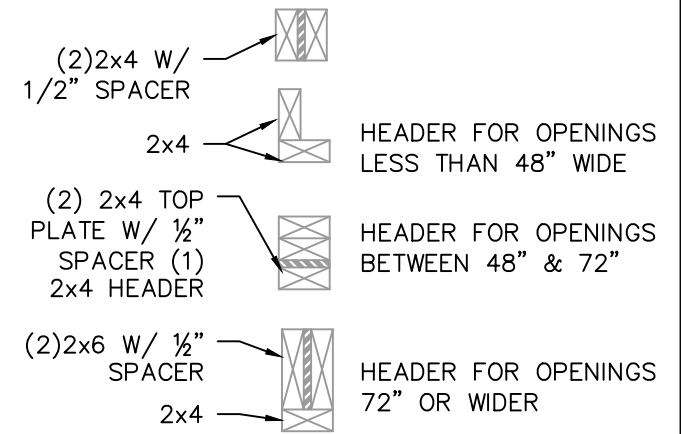

NOTE: FOR 12' HIGH OR GREATER SIDEWALLS,
A 48" MAX OPENING IS ALLOWED



**APEX BUILDERS
AND ASSOCIATES**

504-858-6544

DRAWN BY: TNT

SCALE: NTS

DATE: 02-14-2022

SHEET TITLE: BUILD DETAIL 1

DRAWING NUMBER:

S-109

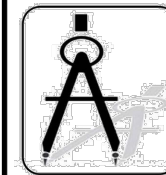

**DAMMON
ENGINEERING, INC.**

554 Old Spanish Trail Slidell, LA 70458 (985) 649-5832

Chief Engineer: Brian Mistich, PE
554 Old Spanish Trail
Slidell, LA 70458

www.dammonengineering.com
info@dammonengineering.com
PHONE: 985-649-5832