

ST. TAMMANY FIRE
 PROTECTION DISTRICT NO. 1
 FIRE STATION #10

2745 LAKESHORE VISTA BLVD
 SLIDELL, LA 70461



JAY GROSS
 CHIEF OF OPERATIONS

ADMINISTRATION
 CHRIS KAUFMANN
 FIRE CHIEF

CHAD DUFFAUT
 CHIEF OF ADMINISTRATION

BOARD OF COMMISSIONERS

- CHAIRMAN TROY BRACKETT
- COMMISSIONER MIKE RICH
 CITY OF SLIDELL
- COMMISSIONER JEFF McDOWELL
 CITY OF SLIDELL
- COMMISSIONER TRACEY POWELL
 ST. TAMMANY PARISH
- COMMISSIONER KEVIN DAVIS
 ST. TAMMANY PARISH

DAMMON
 ENGINEERING, INC.
 LOUISIANA & MISSISSIPPI

Chief Engineer: Brian Misch, PE
 554 Old Spanish Trail
 Slidell, LA 70458
 www.dammonengineering.com
 info@dammonengineering.com
 PH: 985.649.5832

#	DESCRIPTION	DATE

SEAL:

NEW FIRE STATION #10
 ST. TAMMANY FIRE PROTECTION
 DISTRICT NO. 1

2745 LAKESHORE VISTA BLVD
 SLIDELL, LA 70461

JOB No: 2519 DATE: 12-05-2025
 DRAWN BY: CKD CHECKED BY: JMS

SHEET TITLE:
 COVER SHEET

DRAWING NUMBER:
GOO1

ABBREVIATIONS

Table of abbreviations for various construction materials and components, including symbols used as abbreviations, abbreviations, and symbols used as abbreviations.

ANNOTATION SYMBOL LEGEND

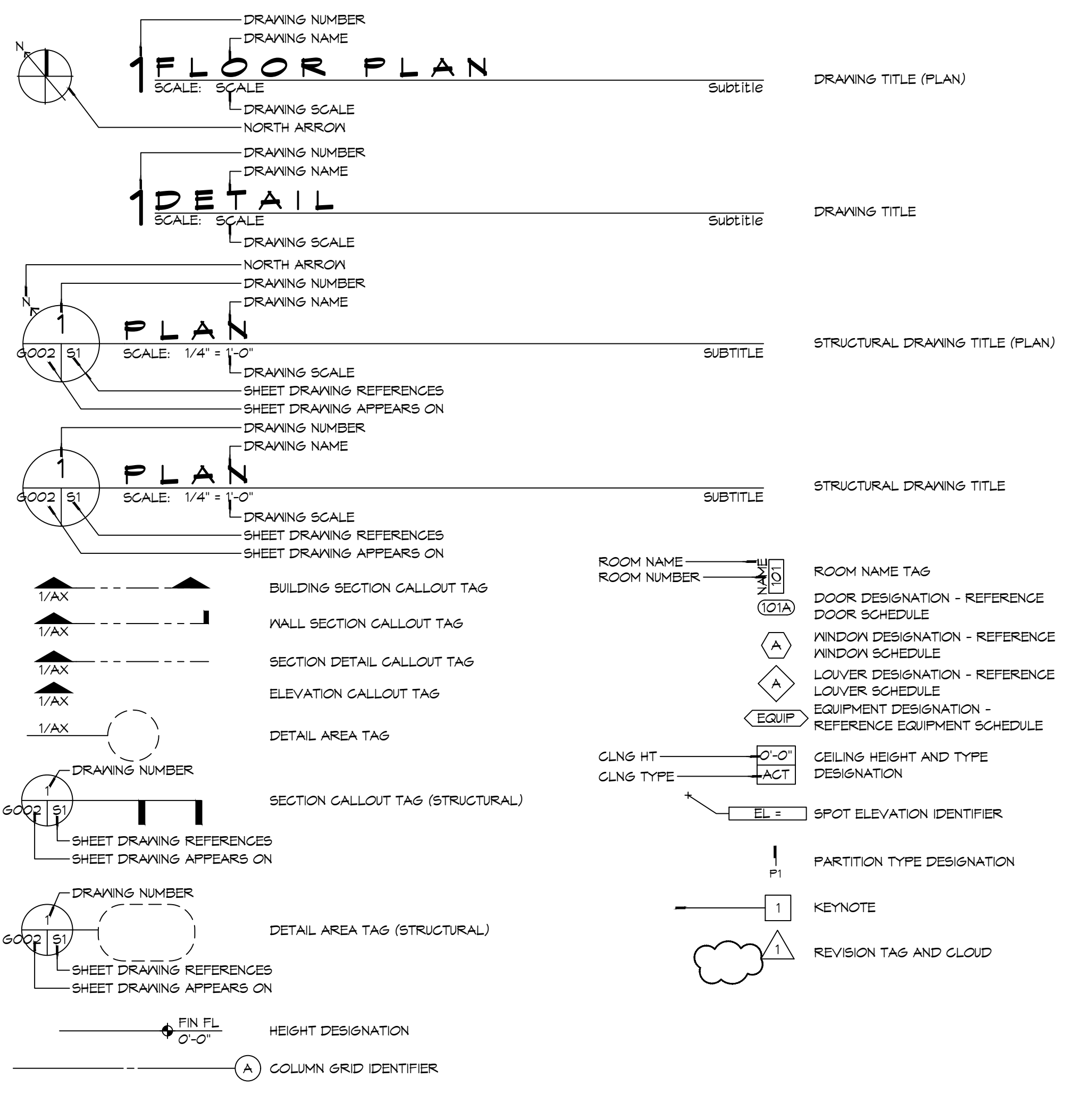

MATERIAL DESIGNATIONS

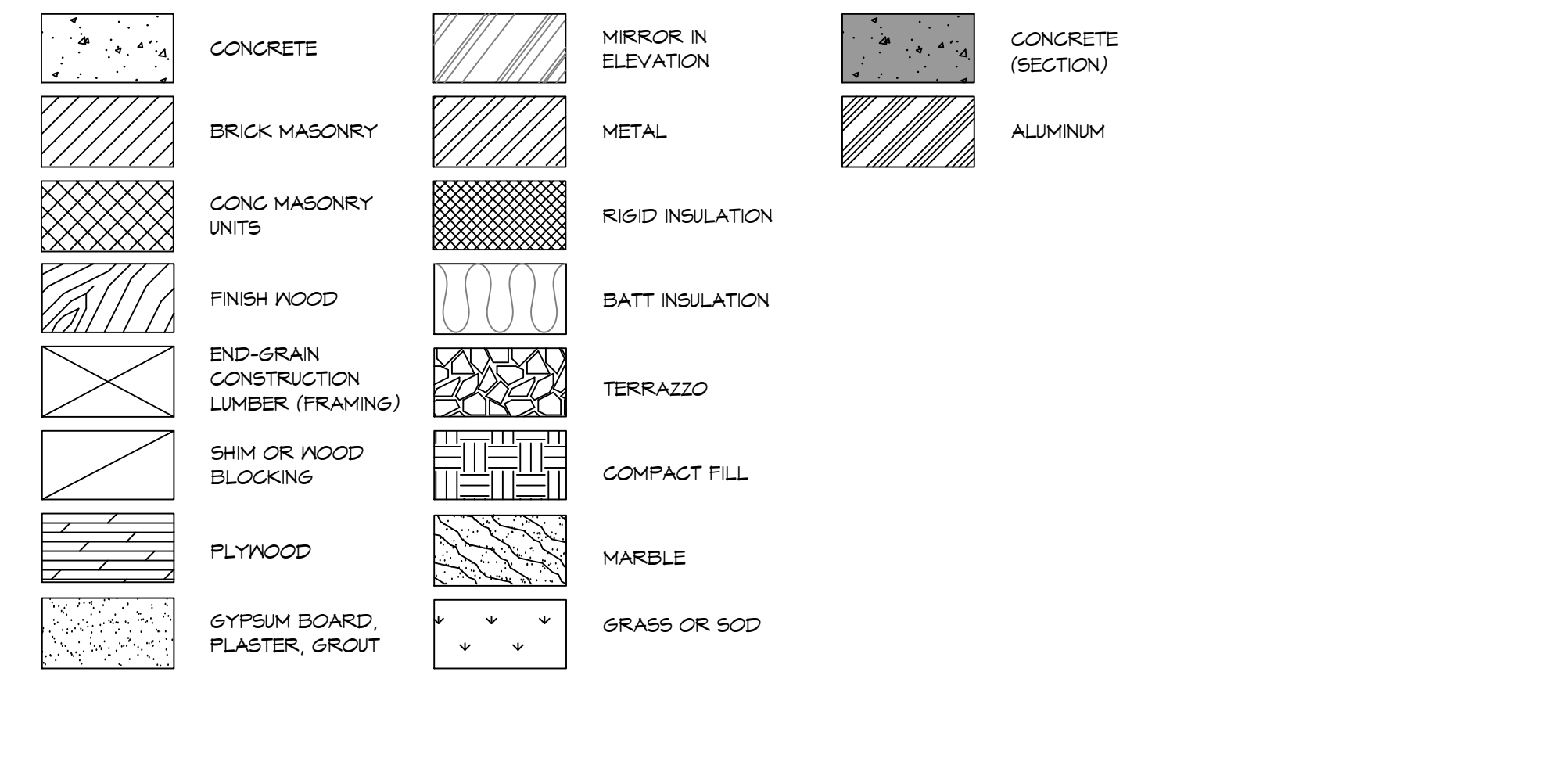

PROJECT LOCATION MAP

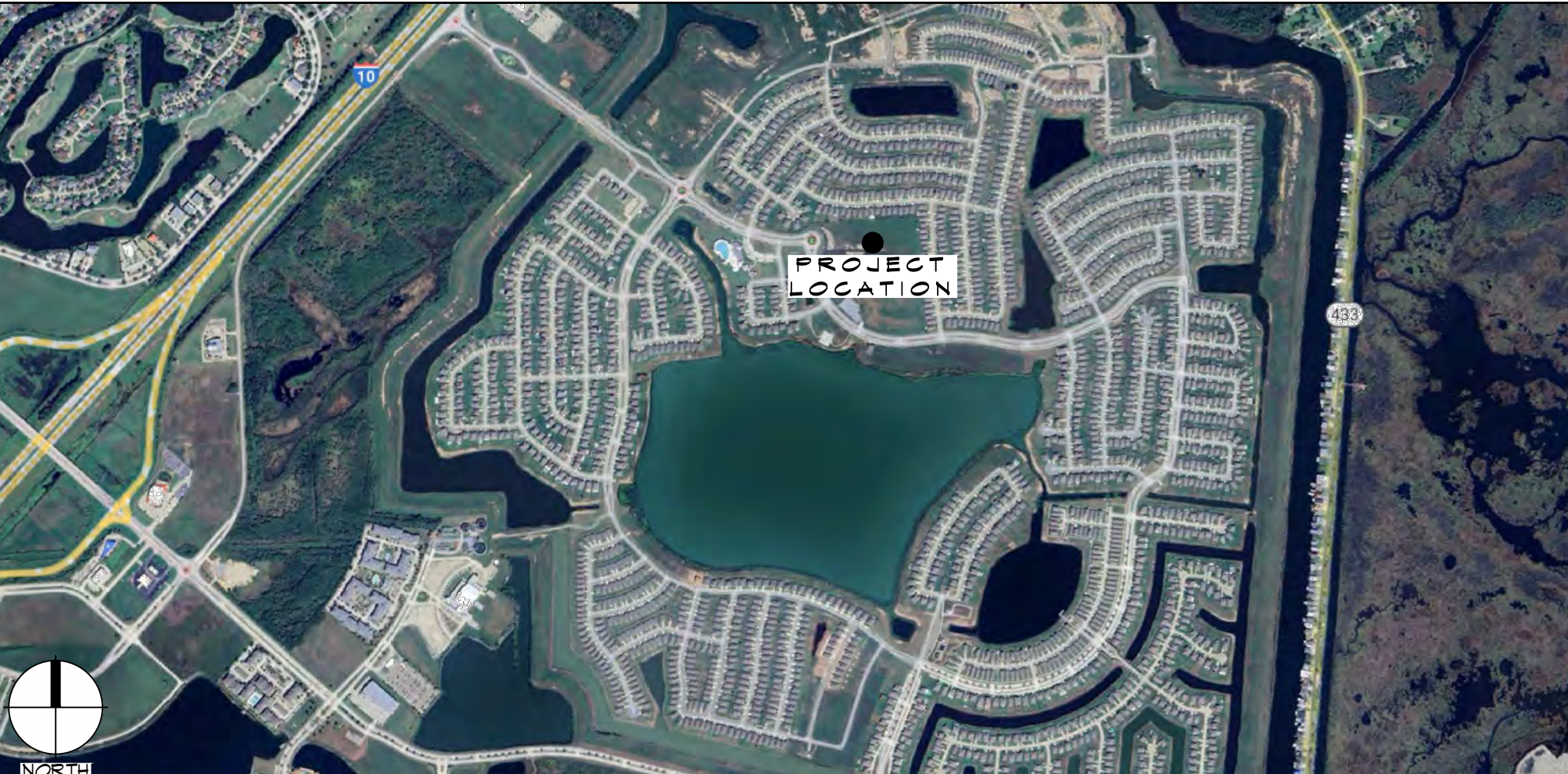

PROJECT STATISTICS

Table of project statistics including square footage, living quarters, apparatus bay, total enclosed space, project location, owner, and sheet list table.

GENERAL NOTES

- List of general notes regarding the application of notes, construction set requirements, contract documents, materials, and workmanship.

DAMMON ENGINEERING, INC. LOUISIANA & MISSISSIPPI logo and contact information.

Table with columns for #, DESCRIPTION, REVISIONS, and DATE.

Table with columns for #, DESCRIPTION, and SEAL.

Project title: NEW FIRE STATION #10 ST. TAMMANY FIRE PROTECTION DISTRICT No. 1. Drawing number: GOO2. Sheet title: GENERAL INFORMATION SHEET.

FILE NAME: A:\Projects\2013\2013-01-01\2013-01-01\2013-01-01\2013-01-01.dwg PLOT DATE: 2013-10-24 10:00:00 AM PLOT SCALE: 1/8" = 1'-0" PLOT DATE: 10/24/13 10:00:00 AM

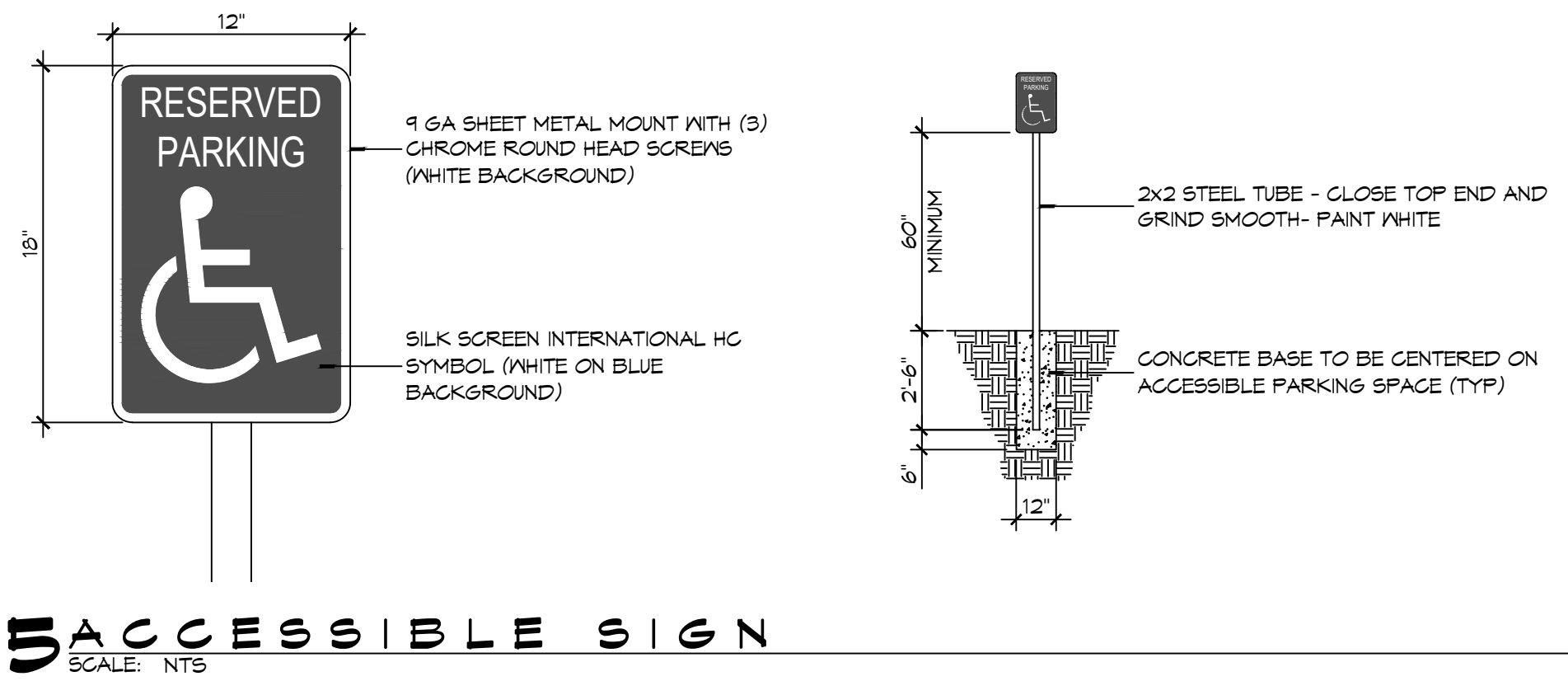

ACCESSIBLE SIGN
SCALE: NTS

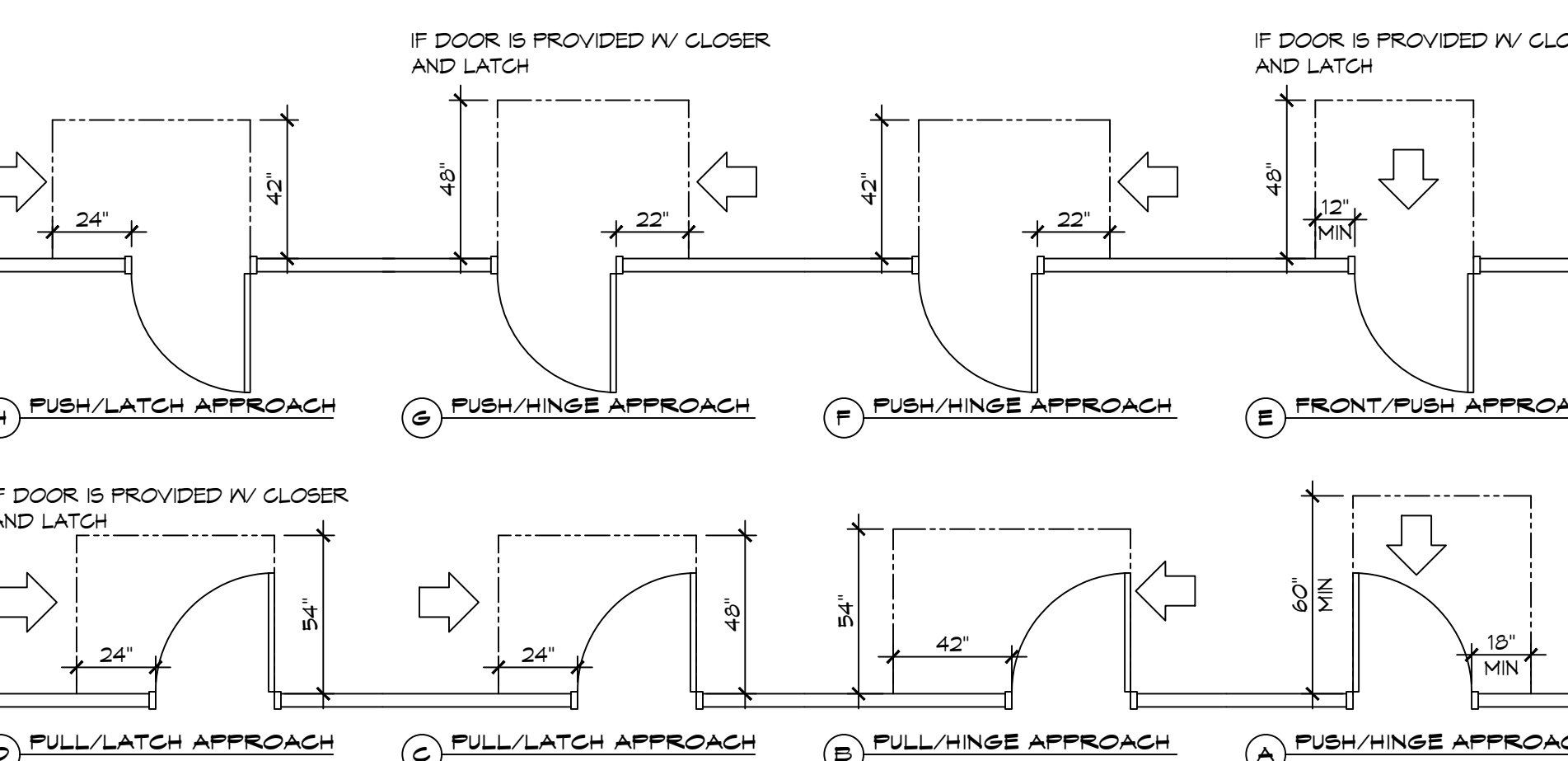
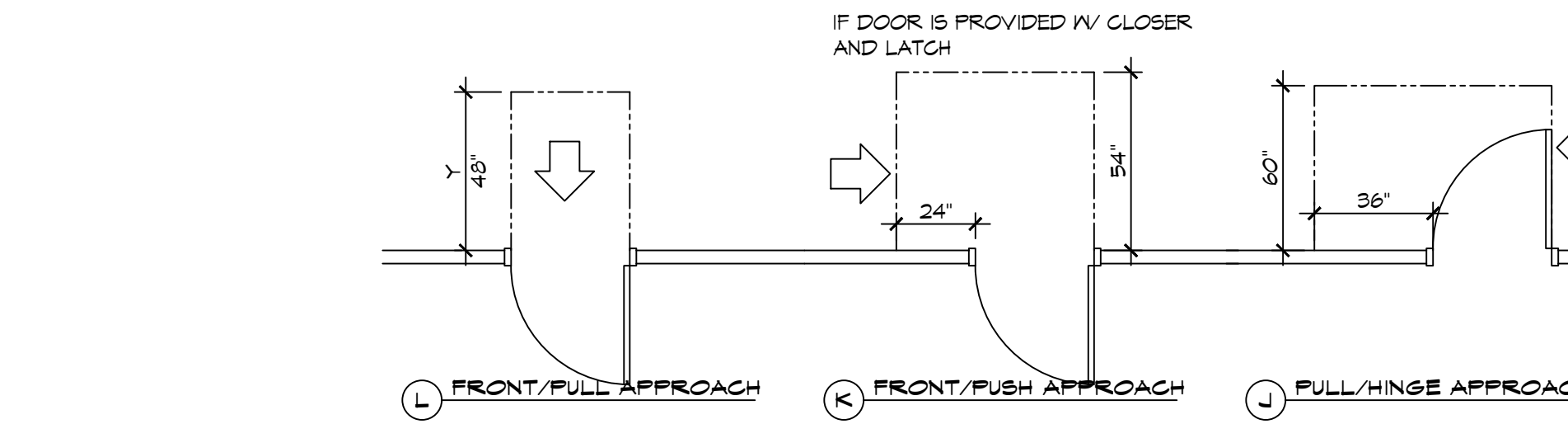

3 ADA DOOR CLEARANCES
SCALE: 1/4" = 1'-0"

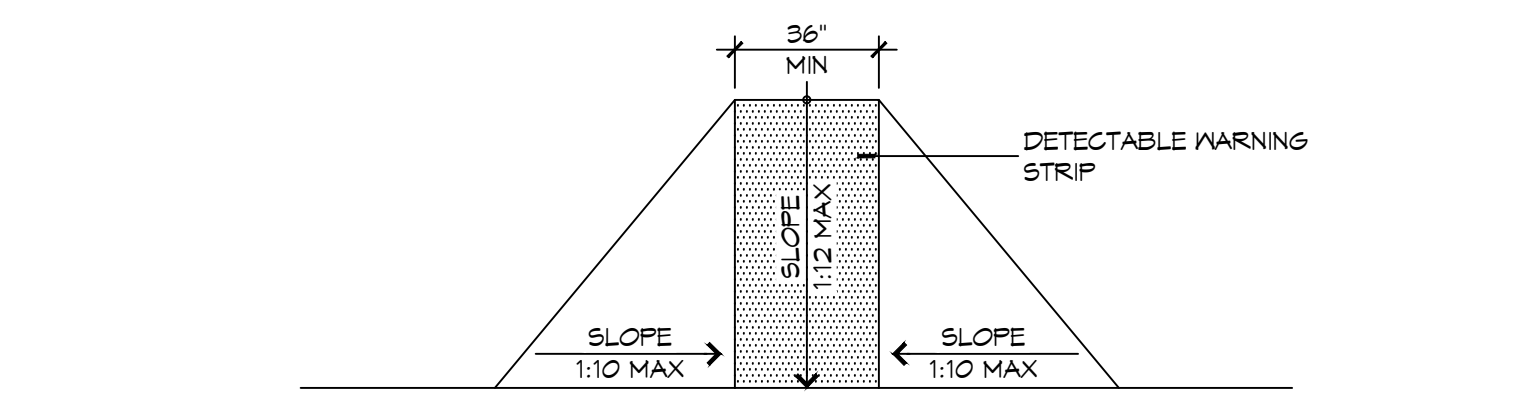

FLARED RAMPS

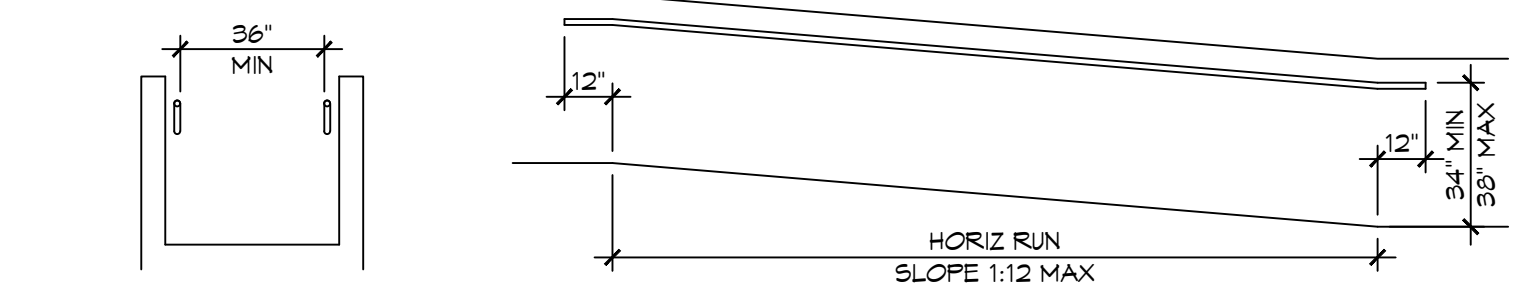

WALL EDGE PROTECTION

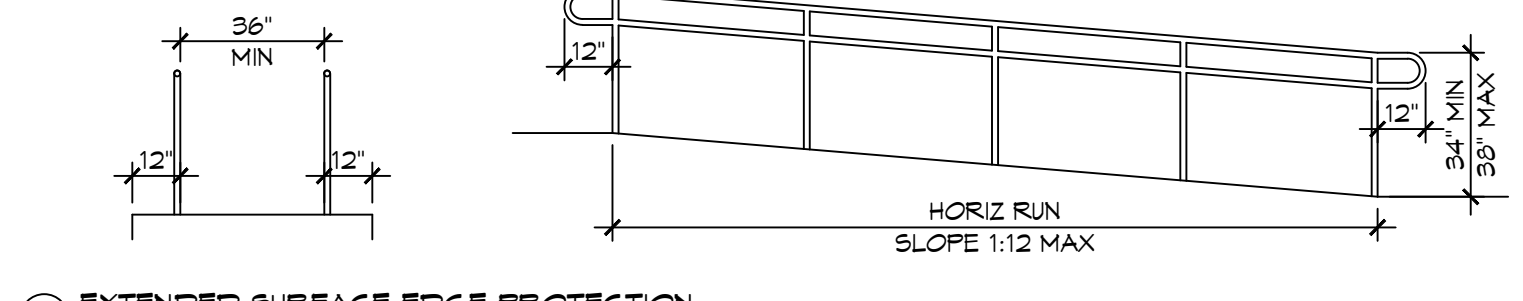

EXTENDED SURFACE EDGE PROTECTION

4 ACCESSIBLE RAMPS
SCALE: 1/4" = 1'-0"

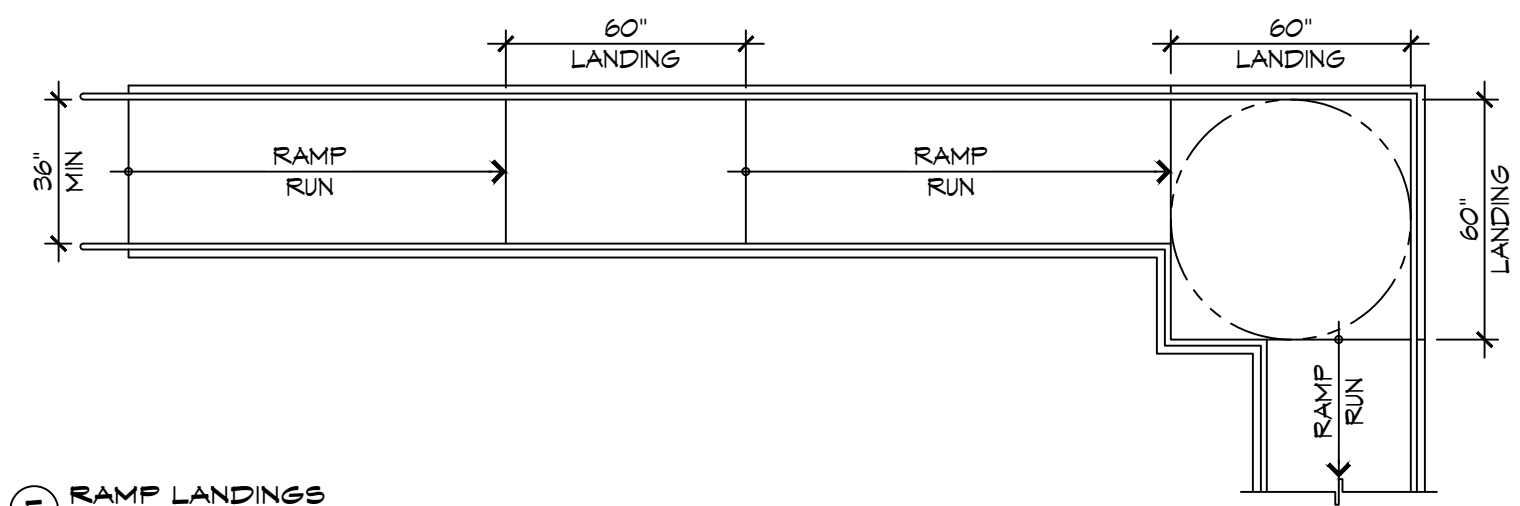

RAMP LANDINGS

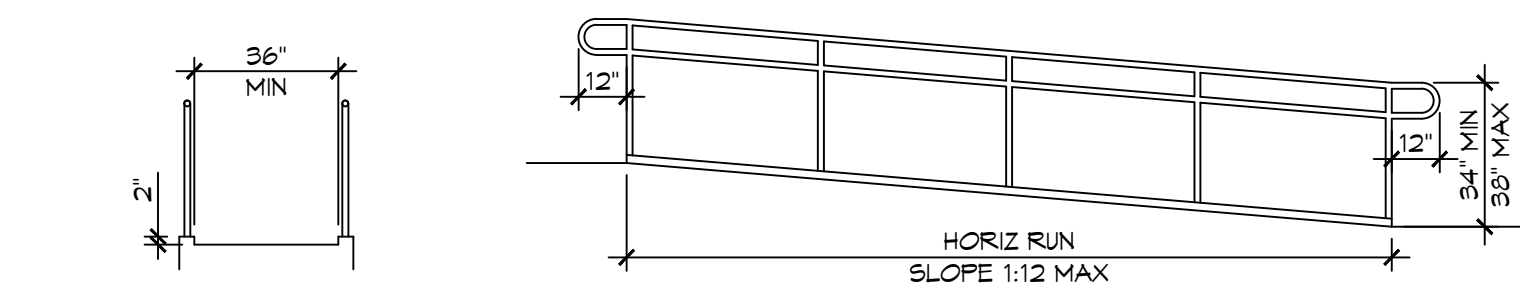

CURB EDGE PROTECTION

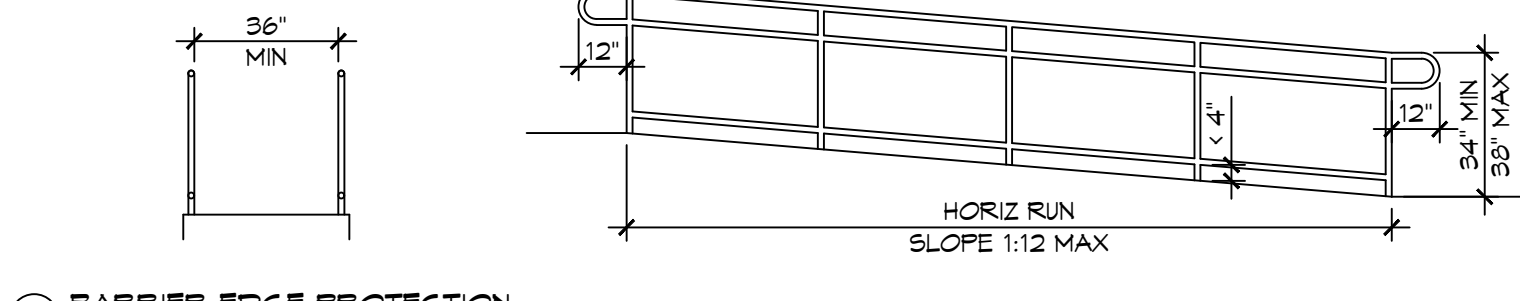

BARRIER EDGE PROTECTION

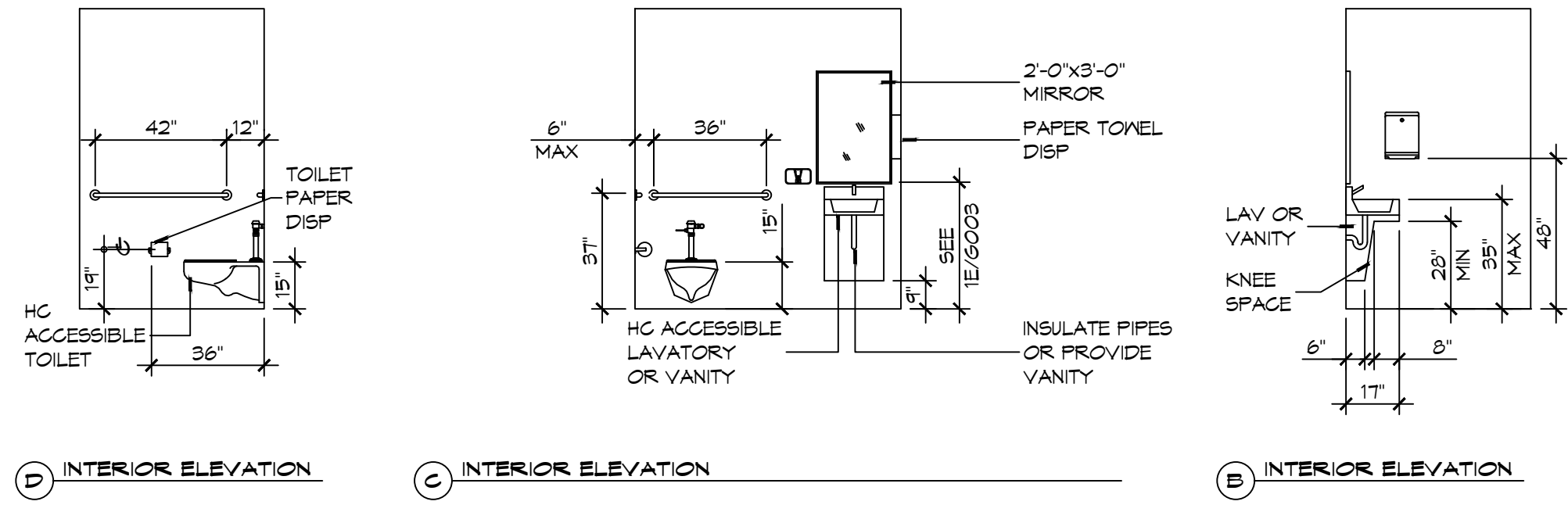

2 RESTROOM CLEARANCES
SCALE: 1/4" = 1'-0"

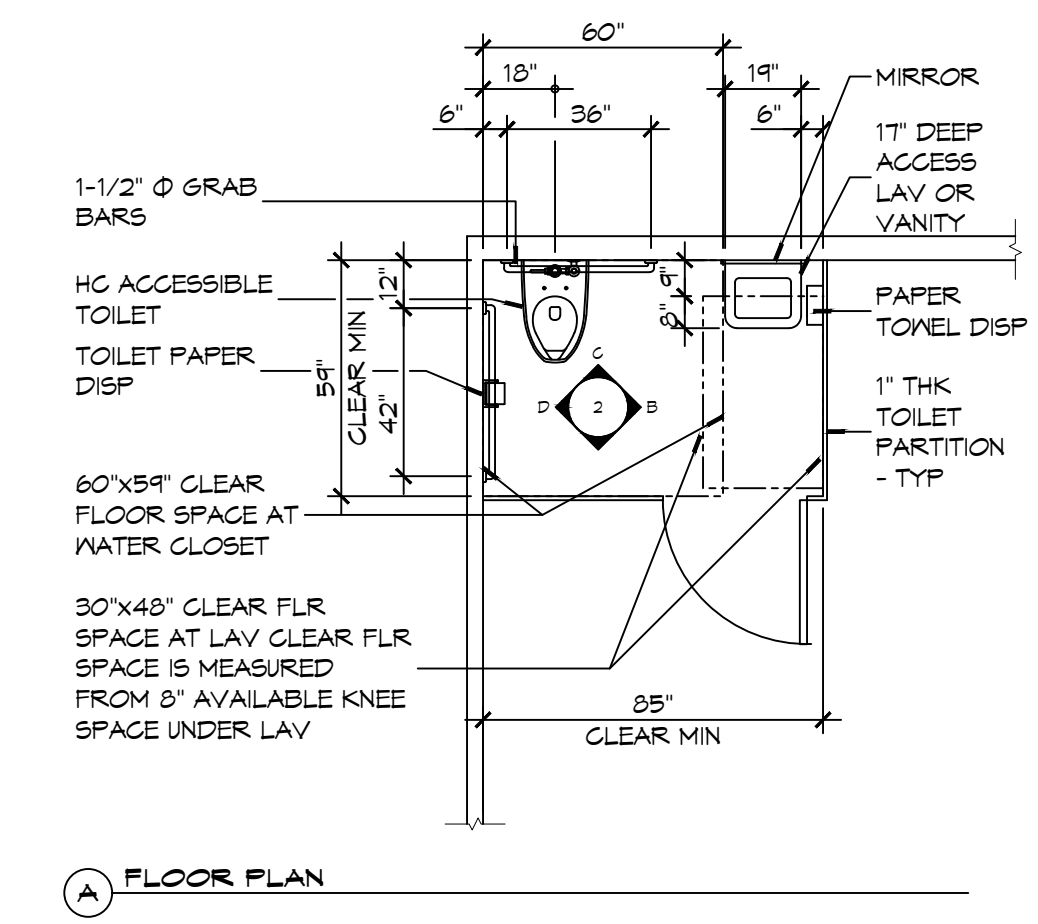

FLOOR PLAN

ACCESSIBILITY NOTES

- DOOR CLEARANCE NOTES**
ALCOVES SHALL COMPLY WITH THE CLEARANCES FOR FRONT APPROACHES, 31/6003 - 3K/6003.
DOOR HARDWARE SHALL BE LEVER TYPE.
MAX DOOR OPENING FORCE:
INTERIOR HINGED DOORS: 5 LBF
EXTERIOR HINGED DOORS: 8.5 LBF
SLIDING OR FOLDING DOORS: 5 LBF
FIRE DOORS SHALL HAVE THE MINIMUM OPENING FORCE ALLOWABLE BY THE APPROPRIATE ADMINISTRATIVE AUTHORITY.
HARDWARE REQUIRED FOR ACCESSIBLE DOOR PASSAGE SHALL BE MOUNTED NO HIGHER THAN 48" AND NOT LESS THAN 34" ABOVE FINISHED FLOOR.
THE FLOOR OR GROUND AREA WITHIN THE REQUIRED CLEARANCES SHALL BE LEVEL AND CLEAR.
THRESHOLDS AT DOORWAYS SHALL NOT EXCEED 3/4" IN HEIGHT FOR EXTERIOR SLIDING DOORS OR 1/2" FOR OTHER TYPES OF DOORS. RAISED THRESHOLDS AND FLOOR LEVEL CHANGES AT ACCESSIBLE DOORWAYS SHALL BE BEVELED WITH A SLOPE NO GREATER THAN 1:2.
DOORWAYS SHALL HAVE A MINIMUM CLEAR OPENING OF 32" WITH THE DOOR OPEN 90°, MEASURED BETWEEN THE FACE OF THE DOOR AND THE OPPOSITE STOP. OPENINGS MORE THAN 24" IN DEPTH SHALL MAINTAIN 32" MIN CLEARANCE.
- RAMP NOTES**
THE CLEAR SPACE BETWEEN THE HANDRAIL AND THE WALL SHALL BE MIN 1-1/2" CLEAR.
GRIPPING SURFACES SHALL BE CONTINUOUS AND UNOBSTRUCTED. ENDS OF HANDRAILS SHALL BE EITHER ROUNDED OR RETURNED SMOOTHLY TO FLOOR, WALL, OR POST.
HANDRAILS SHALL NOT ROTATE WITHIN THEIR FITTINGS.
THE CROSS SLOPE OF RAMP SURFACES SHALL BE NO GREATER THAN 1:50.
OUTDOOR RAMPS AND THEIR APPROACHES SHALL BE DESIGNED SO THAT WATER WILL NOT ACCUMULATE ON WALKING SURFACES.
RAMPS AND LANDINGS WITH DROP-OFFS SHALL HAVE CURBS, WALLS, RAILINGS, OR PROJECTING SURFACES THAT PREVENT PEOPLE FROM SLIPPING OFF THE RAMP. CURBS SHALL BE A MINIMUM OF 2" HIGH.
HANDRAILS SHALL BE PROVIDED ALONG BOTH SIDES OF RAMP SEGMENTS. THE INSIDE HANDRAIL ON SWITCHBACK OR DOGLEG RAMPS SHALL ALWAYS BE CONTINUOUS.
RAMP LANDINGS SHALL BE AT LEAST AS WIDE AS THE RAMP RUN LEADING TO IT.

GENERAL SITE ACCESSIBILITY NOTES

- ACCESSIBILITY SIGNAGE SHALL COMPLY WITH ADAAG 2010 GUIDELINES SECTION 303.7.
- SEE SHEET 0003 FOR ACCESSIBLE RAMP AND HANDRAIL DESIGNS WHERE THEY OCCUR.
- ALL ACCESSIBLE PARKING SPACES AND AISLES THAT SERVE THEM SHALL COMPLY WITH ADAAG 2010 GUIDELINES SECTIONS 302.4 AND 302.5.
- OPENINGS IN GROUND SURFACES SHALL COMPLY WITH ADAAG 2010 GUIDELINES SECTION 302.3.
- VERTICAL CHANGES IN ELEVATION ALONG ALL ACCESSIBLE ROUTES SHALL COMPLY WITH ADAAG 2010 GUIDELINES SECTIONS 303.2, 303.3, AND 303.4.
- PARKING SPACES DESIGNATED AS ACCESSIBLE SHALL INCLUDE THE INTERNATIONAL SYMBOL OF ACCESSIBILITY COMPLYING WITH ADAAG 2010 GUIDELINES SECTIONS 303.2.1 AND 302.6.
- ALL ACCESSIBLE PARKING SPACES AND ROUTES SERVING THEM SHALL HAVE A ROUGH, SLIP-RESISTANT SURFACE OR LIGHT BROOM FINISH IN COMPLIANCE WITH ADAAG 2010 GUIDELINES SECTION 302.1.

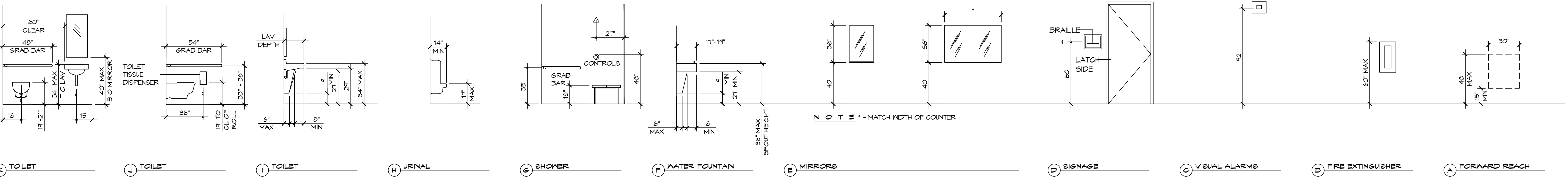
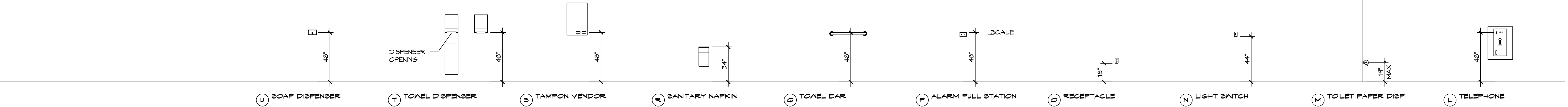

1 MOUNTING HEIGHTS
SCALE: 1/4" = 1'-0"

DAMMON ENGINEERING, INC.
LOUISIANA & MISSISSIPPI
www.dammonengineering.com
info@dammonengineering.com
PH: 985.649.5832
Chief Engineer: Brian Misch, PE
554 Old Spanish Trail
Slidell, LA 70458

#	DESCRIPTION	DATE

SEAL:

NEW FIRE STATION #10
ST. TAMMANY FIRE PROTECTION DISTRICT NO. 1
248 LAKESHORE VISTA BLVD
SLIDELL, LA 70461
JOB No: 2519 DATE: 12-05-2025
DRAWN BY: JME CHECKED BY: GKD
SHEET TITLE: ACCESSIBILITY INFORMATION
DRAWING NUMBER:
GOOB
SHEET No: 3 of 37

FILE NAME: A:\-Dammam\LS101 - Fire Station 410\Sheet\LS101-1.dwg, Scale: 1/8" = 1'-0", Plot Date: 12/15/2025, 12:05:33 PM, Plot Size: 11.00 x 17.00, Plot Scale: 1.00, Plot Orientation: Landscape

LIFE-SAFETY INFORMATION

APPLICABLE CODES			
NFPA 101 LIFE-SAFETY CODE 2015			
OCCUPANCY TYPE(S) AND CHAPTER(S)			
ROOMING OR LODGING (CHAPTER 26)			
BUSINESS (CHAPTER 30)			
STORAGE (ORDINARY HAZARD) (CHAPTER 42)			
MULTIPLE, MIXED, OR SEPARATE OCCUPANCY (REFERENCE CHAPTER 6)			
CLASSIFICATION OF HAZARD OF CONTENTS			
(REFERENCE: OCCUPANCY CHAPTER AND 8.2.2: SPECIFY LOW, ORDINARY, OR HIGH)			
CONSTRUCTION TYPE(S) (REFERENCE: CHAPTERS, TABLE A.8.2.1.2 AND COMMENTARY TABLE 8.1 IN HANDBOOK)			
V(000)			
MINIMUM CONSTRUCTION REQUIREMENTS (REFERENCE OCCUPANCY CHAPTER)			
APPLICABLE DEFINITIONS (REFERENCE: CHAPTER 2)			
N/A			
OCCUPANCY			
OCCUPANCY LOAD CALCULATIONS (REFERENCE: TABLE 7.3.1.2)			
OCC/FUNCTION OF SPACE	FLOOR AREA PER OCC (SF)	ACTUAL SF	OCCUPANT LOAD
ROOMING & LODGING	200	2,624 SF	14
STORAGE (S-2)	500	3,902 SF	8
	TOTAL	6,526 SF	23
INCIDENTAL USE AREAS AND REQUIRED SEPARATION			
ROOM OR AREA	SEPARATION		
N/A			
MEANS OF EGRESS			
NUMBER OF EXITS (REFERENCE: OCCUPANCY CHAPTER AND TABLE A.7.6)			
3			
MINIMUM EXIT SEPARATION DISTANCE FOR REMOTELY LOCATED EXITS			
(REFERENCE: SECTION 7.5; SPECIFY 1/2 OR 1/3 DIAGONAL DISTANCE OF AREA SERVED)			
1/3 DIAGONAL = 30'-10"			
MAXIMUM DEAD-END CORRIDORS (REFERENCE: OCCUPANCY CHAPTER AND TABLE A.7.6)			
ROOMING & LODGING	NR		
STORAGE	100'		
MAXIMUM COMMON PATH OF TRAVEL (REFERENCE: OCCUPANCY CHAPTER AND TABLE A.7.6)			
DISTANCE			
ROOMING & LODGING	NR		
STORAGE	100'		
MAXIMUM TRAVEL DISTANCE TO EXITS (REFERENCE: OCCUPANCY CHAPTER AND TABLE A.7.6)			
ROOMING & LODGING	NR		
STORAGE	400'		
CAPACITY OF MEANS OF EGRESS (REFERENCE: 7.3 AND TABLE 7.3.3.1)			
COMPONENT	OCCUPANT LOAD	X CAPACITY FACTOR	MINIMUM WIDTH
EXITS	23	0.2	5"
*MAIN ENTRANCE MUST BE SIGNED TO ACCOMMODATE 1/2 OCCUPANT LOAD OF BUILDING			
FIRE RESISTANCE RATING REQUIREMENTS			
CHAPTER 8			
EXTERIOR BEARING WALLS	(REFERENCE TABLE A.8.2.1.2)	0 HOURS	
INTERIOR BEARING WALLS	(REFERENCE TABLE A.8.2.1.2)	0 HOURS	
COLUMNS	(REFERENCE TABLE A.8.2.1.2)	0 HOURS	
BEAMS, GIRDERS, TRUSSES, AND ARCHES	(REFERENCE TABLE A.8.2.1.2)	0 HOURS	
FLOOR-CEILING ASSEMBLIES	(REFERENCE TABLE A.8.2.1.2)	0 HOURS	
ROOF-CEILING ASSEMBLIES	(REFERENCE TABLE A.8.2.1.2)	0 HOURS	
INTERIOR NON-BEARING WALLS	(REFERENCE TABLE A.8.2.1.2)	0 HOURS	
EXTERIOR NON-BEARING WALLS	(REFERENCE TABLE A.8.2.1.2)	0 HOURS	
SHAFT ENCLOSURE	(SECTION 8.6.5)	0 HOURS	
EXIT ENCLOSURE		1 HOUR	
OPENING PROTECTIVES (CHAPTER 8, TABLE 8.3.4.2)			
COMPONENT	WALLS & PART FIRE RATING (HR)	FIRE DOOR ASSEMBLIES (HR)	FIRE WINDOW ASSEMBLIES (HR)
ELEVATOR	1 HR	1 HR	1 HR
STAIRWAYS	1 HR	1 HR	1 HR
SMOKE BARRIERS	1 HR	1/3 HR	1/3 HR
ADDITIONAL CODE REQUIREMENTS (OCCUPANCY CHAPTER 36)			
EXTINGUISHMENT REQUIREMENTS (SPRINKLER (REQUIRED))			
DETECTION, ALARM, AND COMMUNICATION SYSTEMS	YES		
EMERGENCY LIGHTING	PER 90.2.6		
EMERGENCY LIGHTING	PER 90.2.11.2		
ALLOWABLE HEIGHT AND BUILDING AREA	PER IBC EQUIVALENT CONSTRUCTION TYPE		
CONSTRUCTION TYPE (NFPA)	V(000)		
CONSTRUCTION TYPE (IBC)	VB		
MAXIMUM HEIGHT IN STORIES	(REF: IBC TABLE 503)	(R-2) 3	(S-2) 4
MAXIMUM HEIGHT IN FEET	(REF: IBC TABLE 503)	50 FEET	
MAXIMUM AREA IN SQUARE FEET	(REF: IBC TABLE 503)	(R-2) 12,000 SF	(S-2) 21,000 SF

BUILDING CODE INFORMATION

APPLICABLE CODES		
BC 2021		
OCCUPANCY TYPE OF GROUP(S) (IBC 2021 CHAPTER 13)		
STORAGE (S-2)		
RESIDENTIAL (R-2)		
CONSTRUCTION TYPE(S) (TABLE 503)		
VB		
ALLOWABLE HEIGHT AND BUILDING AREA LIMITED BY TYPE OF CONSTRUCTION		
MAXIMUM HEIGHT IN STORIES (SECTION 503 & 504, TABLE 503)	2	
MAXIMUM AREA IN SQUARE FEET (SECTION 503, 506 & 507, TABLE 503)	(R-2) 12,000 SF	(S-2) 21,000 SF
MIXED USED OCCUPANCY		
SECTION 503		
INCIDENTAL ACCESSORY OCCUPANCIES (HR) (TABLE 503.2.5)		
ROOM OR AREA	SEPARATION	
N/A	N/A	
REQUIRED SEPARATION OR OCCUPANCIES (HR) (TABLE 503.4)		
N/A		
FIRE RESISTANCE RATING REQUIREMENTS FOR BUILDING ELEMENTS		
CHAPTER 8, TABLE 8.01		
STRUCTURAL FRAMES	0 HOURS	
EXTERIOR BEARING WALLS	0 HOURS	
INTERIOR BEARING WALLS	0 HOURS	
EXTERIOR NON-BEARING WALLS	0 HOURS	
INTERIOR NON-BEARING WALLS	0 HOURS	
FLOOR CONSTRUCTION (INC SUPPORTING BEAMS & JOISTS)	0 HOURS	
ROOF CONSTRUCTION (INC SUPPORTING BEAMS & JOISTS)	0 HOURS	
MAXIMUM AREA OF EXTERIOR WALL OPENINGS		
TABLE 705.3		
NOTES ON SPECIFIC, PERTINENT PLAN ISSUES		
N/A		
FIRE WALLS		
SECTION 706, TABLE 706.4	NO	
REQUIRED?		
IF YES THEN NOTE REQUIRED RATING		
FIRE BARRIERS		
SECTION 707		
SHAFT ENCLOSURE(S) - NOT REQUIRED RATINGS (SECTION 708.4)	NO PER 708.2.1	
EXIT ENCLOSURE - NOTE REQUIRED RATINGS (SECTION 1022.1)	1 HOUR	
EXIT PASSAGEWAY - NOTE REQUIRED RATINGS (SECTION 1023.3)	1 HOUR	
HORIZONTAL EXIT - NOTE REQUIRED RATINGS (SECTION 1025.1)	2 HOURS	
ATRIUMS - NOTE REQUIRED RATINGS (SECTION 404.6)	N/A	
SEPARATION FROM STAGE (SECTION 410.5)	N/A	
OCCUPANT LOADS		
IBC 2004 SECTION 1004, TABLE 1004.1.1)		
OCCUPANCY/FUNCTION SPACE	FLOOR AREA/OCCUPANT (SF)	OCCUPANT LOAD
R-2	2,541 SF / 200 SF PER OCCUPANT	13 OCCUPANTS
S-2	3,715 SF / 500 SF PER OCCUPANT	8 OCCUPANTS
	TOTAL	21
EXIT REQUIREMENTS		
(IBC 2012 SECTION 1009)		
NUMBER OF ACCESSIBLE MEANS OF EGRESS REQUIRED PER FLOOR (TABLE 1018.1 & 1021.1)		
FLOOR	# MEANS OF EGRESS REQUIRED	
R-2	2	
S-2	1	
TOTAL WIDTH OF EXITS		
(OCCUPANT LOAD ÷ # OF MEANS OF EGRESS) X (FACTOR IN SECTION 1009)		
OCCUPANT LOAD	# OF EXITS PROVIDED	MINIMUM EXIT WIDTH (INCHES)
13	2	5.1
19	1	9.1500
19	1	0.2
MINIMUM EXIT ACCESS TRAVEL DISTANCE (TABLE 1016.1)		
250'		
MINIMUM CORRIDOR WIDTH (SECTION 1018.1 & 1005.1)		
44"		
MAXIMUM DEAD END CORRIDOR (SECTION 1018.4)		
50'		
MAXIMUM COMMON PATH OF TRAVEL (SECTION 1014.3)		
100'		
WIND SPEED DESIGN REQUIREMENTS		
THIS BUILDING SHALL BE DESIGNED WITH IBC SEC 1609 AS A FULLY ENCLOSED BLDG USING THE FOLLOWING INFORMATION:		
WIND DESIGN DATA:		
DETERMINATION OF WIND LOADS SHALL BE IN ACCORDANCE WITH IBC SEC 1609.3 (A), (B), OR (C) DEPENDING ON THE RISK CATEGORY		
BASIC WIND SPEED (3 SECOND GUST) =	140 MPH (FIG 1609)	
RISK FACTOR: CATEGORY II BLDG	SURFACE ROUGHNESS =	C
TOPOGRAPHIC FACTOR	1	
DESIGN WIND PRESSURE (ASCE 7-10):	33.6 PSF	
INTERNAL PRESSURE COEFFICIENT (ASCE 7-10):	± 0.18	
LIVE LOADS (SEC 1607)		
ASSEMBLY AREA W/ MOVEABLE SEATS (TABLE 1607.1):	100 PSF	
OFFICE (TABLE 1607.1):	50 PSF	
ROOF LIVE LOADS (TABLE 1607.1):	20 PSF UNIFORM, 300 LB CONCENTRATED	
SNOW LOADS (TABLE 1608):		
GROUND SNOW LOAD (FIG 1608.2):	5 PSF	
CONTRACTOR NOTE:		
EACH CONTRACTOR IS RESPONSIBLE FOR THE CONSTRUCTION OF THE MAIN WIND-FORCE-RESISTING COMPONENT SYSTEM OF THIS BUILDING. EACH CONTRACTOR SHALL SUBMIT A WRITTEN CONTRACTOR'S STATEMENT OF RESPONSIBILITY TO THE BUILDING OFFICIAL AND OWNER PRIOR TO COMMENCEMENT OF WORK THAT THE CONTRACTOR SHALL PROVIDE PERIODIC INSPECTIONS AS REQUIRED BY SEC 1705.		
FLOOD ZONE INFORMATION		
BASED ON THE SURVEY OF THIS PROPERTY BY J.V. BURKES AND ASSOCIATES, INC. THIS PROPERTY IS IN A SPECIAL FLOOD HAZARD AREA. F.I.R.M. COMMUNITY MAP NO 220205 0535 D, REVISED 04/02/1991		
FLOOD ZONE:	AH	
BASE FLOOD ELEVATION	1.0 NGVD	
ELEVATIONS REFER TO NGVD 1929 DATUM		

LIFE-SAFETY LEGEND

SYMBOL	DESCRIPTION
➤	EXITS
45	DOOR FIRE RATING (MINUTES)
36 170	DOOR WIDTH/EGRESS CAPACITY
☒	EXIT LIGHT
FE	FIRE EXTINGUISHER AND CABINET - SEMI-RECESSED
FE	FIRE EXTINGUISHER W/ WALL MTD BRACKET
—	COMMON PATH OF TRAVEL
.....	TOTAL TRAVEL DISTANCE
●	DECISION POINT
---	SMOKE PARTITION
---	ONE-HOUR FIRE RATED PARTITION
---	TWO-HOUR FIRE RATED PARTITION
---	TWO-HOUR FIRE/SMOKE PARTITION
---	FOUR-HOUR RATED PARTITION

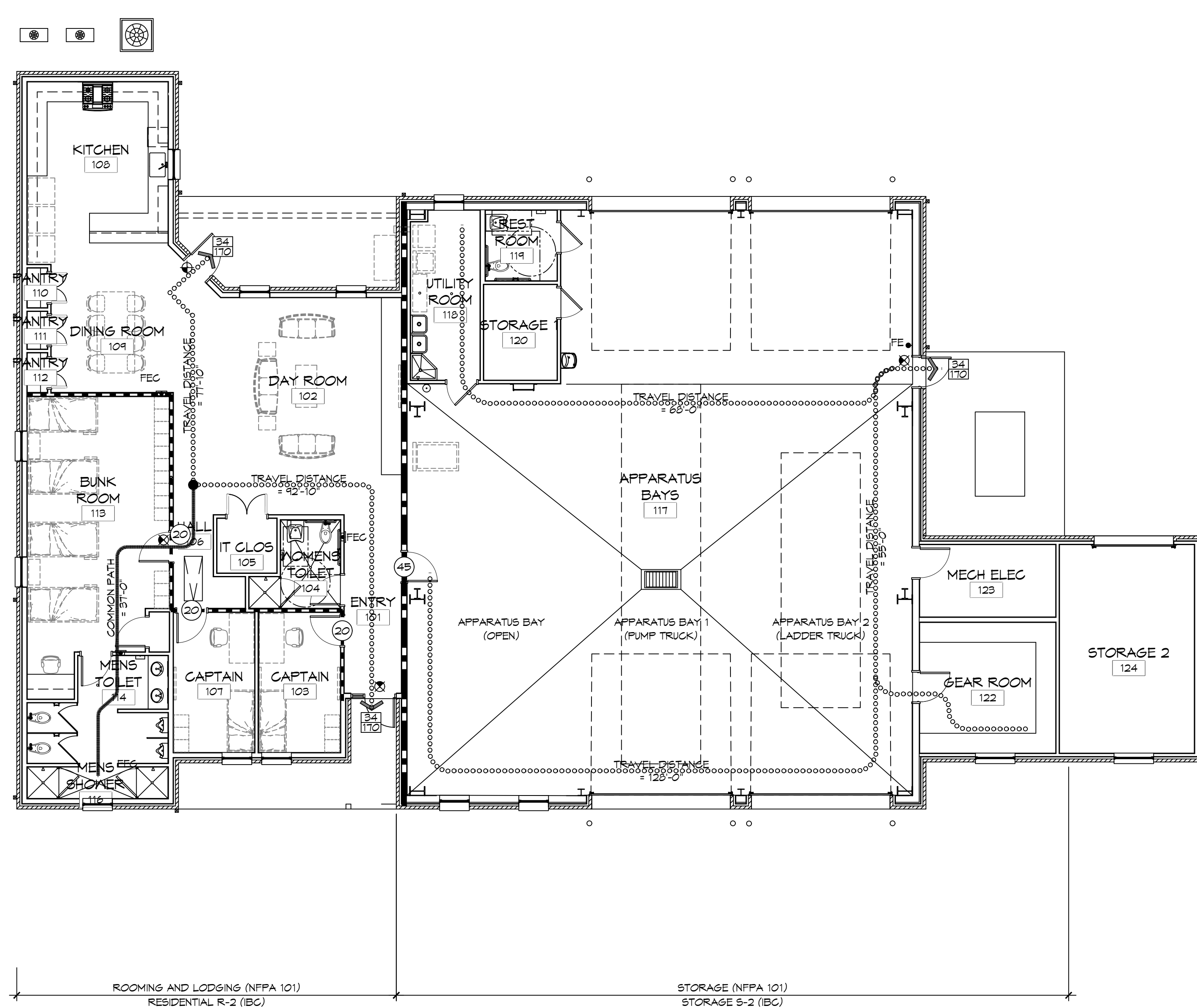

ROOMING AND LODGING (NFPA 101) RESIDENTIAL R-2 (IBC) STORAGE (NFPA 101) STORAGE S-2 (IBC)

1 LIFE-SAFETY PLAN
SCALE: 1/8" = 1'-0"

DAMMON ENGINEERING, INC.
 LOUISIANA & MISSISSIPPI
 Chief Engineer: Brian Misch, PE
 554 Old Spanish Trail
 Slidell, LA 70458
 www.dammoneengineering.com
 info@dammoneengineering.com
 PH: 985.649.5832

#	DESCRIPTION	DATE

SEAL:

NEW FIRE STATION #10	DATE	CHECKED BY
ST. TAMMANY FIRE PROTECTION DISTRICT NO. 1	25/15	CKD
246 LAKESHORE VISTA BLVD SLIDELL, LA 70461	12-05-2025	JMS

SHEET TITLE:
LIFE-SAFETY AND BUILDING CODE INFORMATION

DRAWING NUMBER:
LS101

SHEET No: 4 of 37

FILE NAME: S:\Projects\2015\15-0000\2015-0000.dwg PLOT DATE: 12/05/2015 10:53:12 AM

SITE DRAINAGE LEGEND

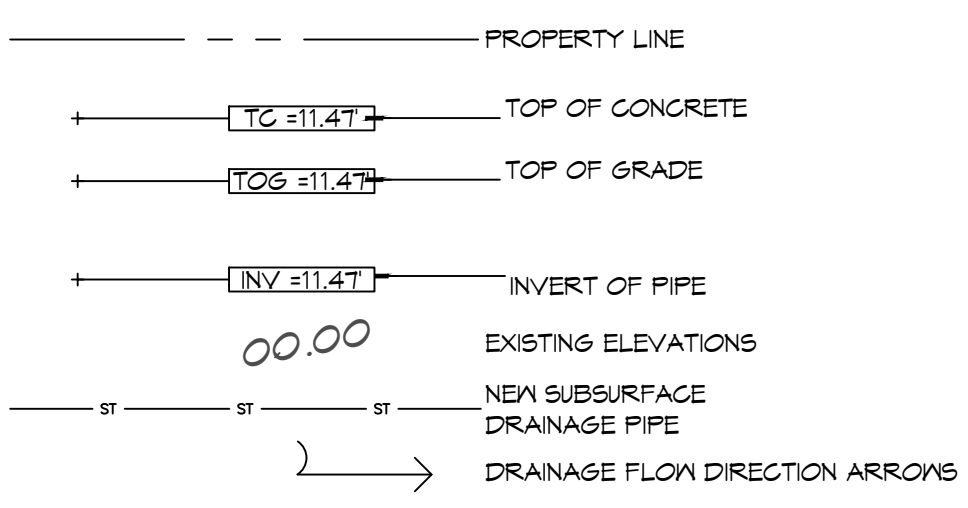

AREA OF FILL (CUBIC YARDS)

2,836 CUBIC YARDS

GENERAL NOTES

- ALL NEW CONCRETE SHALL HAVE A MINIMUM COMPRESSIVE STRENGTH OF 4,000 PSI AT 28 DAYS AND A MINIMUM THICKNESS OF 6". CONCRETE MIX SHALL BE IN ACCORDANCE WITH THE LATEST REVISION OF ASTM C-150 TYPE 1.
- CONCRETE PAVING THICKNESS SHALL VARY AS FOLLOWS:
 - APRONS & LOADING AREAS = 8" THICKNESS
 - DRIVE LANES & PARKING AREAS = 6" THICKNESS
- ALL REINFORCING STEEL SHALL MEET ASTM-A615 (GRADE 60).
- ALL REINFORCING STEEL SHALL BE SECURELY SUPPORTED TO PREVENT BOTH VERTICAL AND HORIZONTAL MOVEMENT DURING CONCRETE PLACEMENT. ALL CONTROL AND EXPANSION JOINTS SHALL BE LOCATED AND INSTALLED AS SHOWN ON THE PAVING PLAN AND IN ACCORDANCE WITH THE MANUFACTURER'S RECOMMENDATIONS.
- ALL SUB GRADE FILL SHALL BE SELECT GRANULAR MATERIAL COMPACTED TO 95% STANDARD PROCTOR DENSITY IN A MAXIMUM OF 6" LIFTS.
- CONTRACTOR SHALL CONTACT THEIR REGULATORY DEPARTMENT OF ENGINEERING PRIOR TO CONDUCTING ANY WORK.
- ANY WORK WITHIN THE ROADWAY OR ADJACENT TO THE ROADWAY CAUSING AN INTERFERENCE TO VEHICULAR TRAFFIC MUST CONFORM TO THE REQUIREMENTS SET FORTH BY THE UNIFORM MANUAL OF TRAFFIC CONTROL DEVICES OF THE STATE OF LOUISIANA. THE CONTRACTOR MUST FURNISH ALL NECESSARY TRAFFIC SIGNS AND/OR BARRICADES AND MAINTAIN THEM DURING CONSTRUCTION ACTIVITY.

DAMMON ENGINEERING, INC.
LOUISIANA & MISSISSIPPI

Chief Engineer: Brian Mistich, PE
554 Old Spanish Trail
Slidell, LA 70458
www.dammonengineering.com
info@dammonengineering.com
PH: 985.649.5832

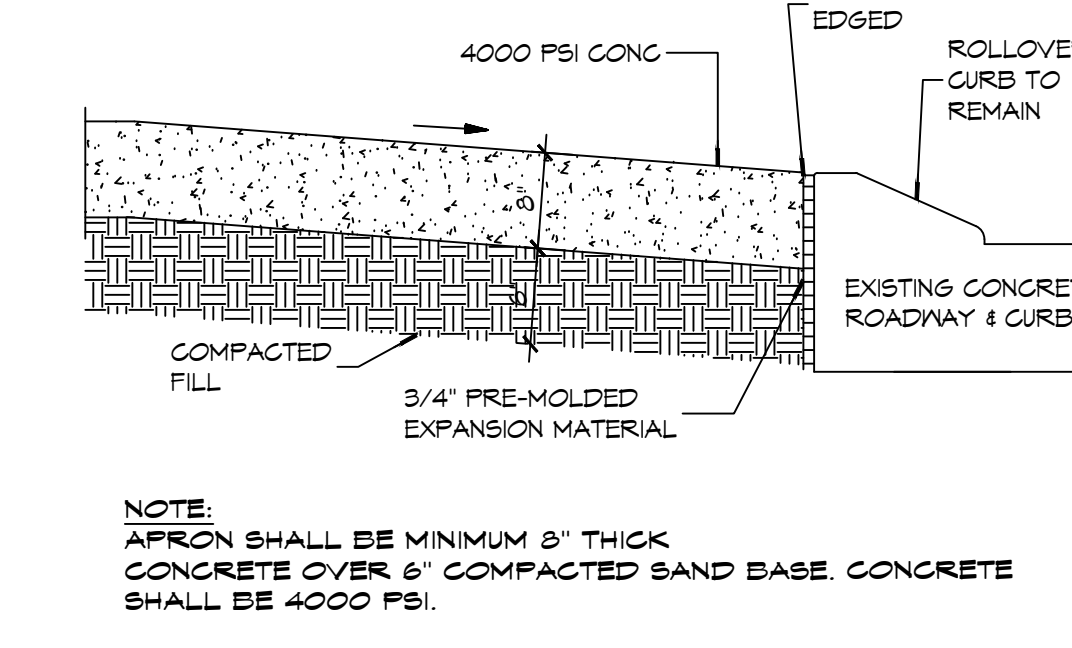
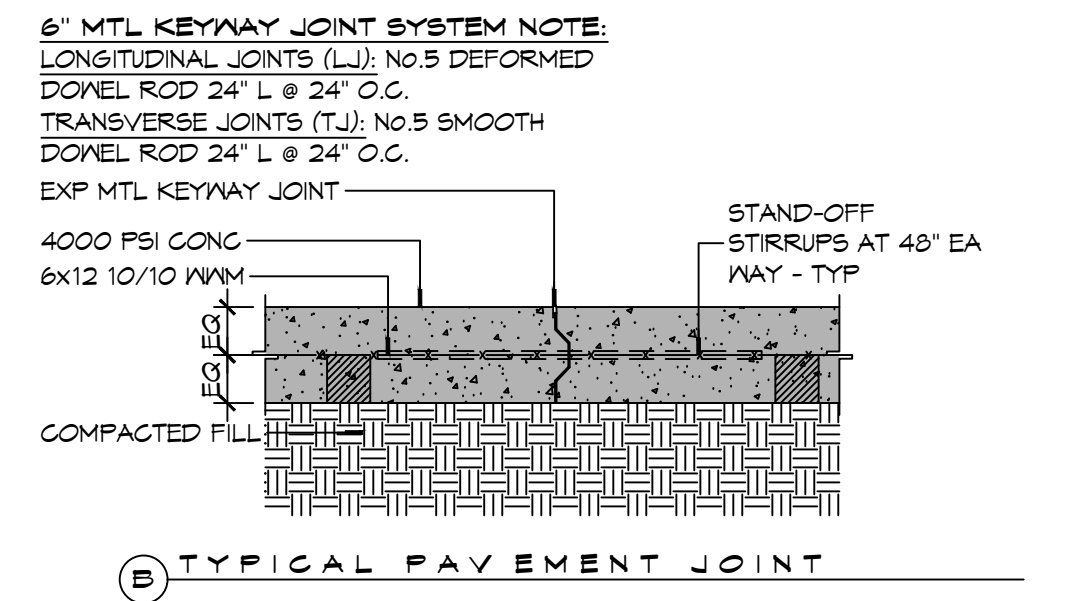
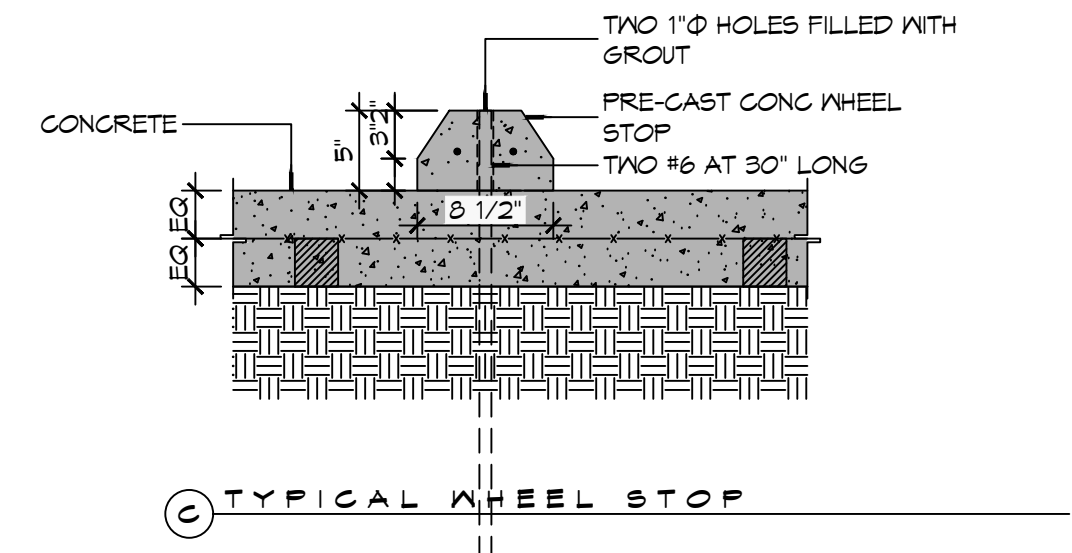
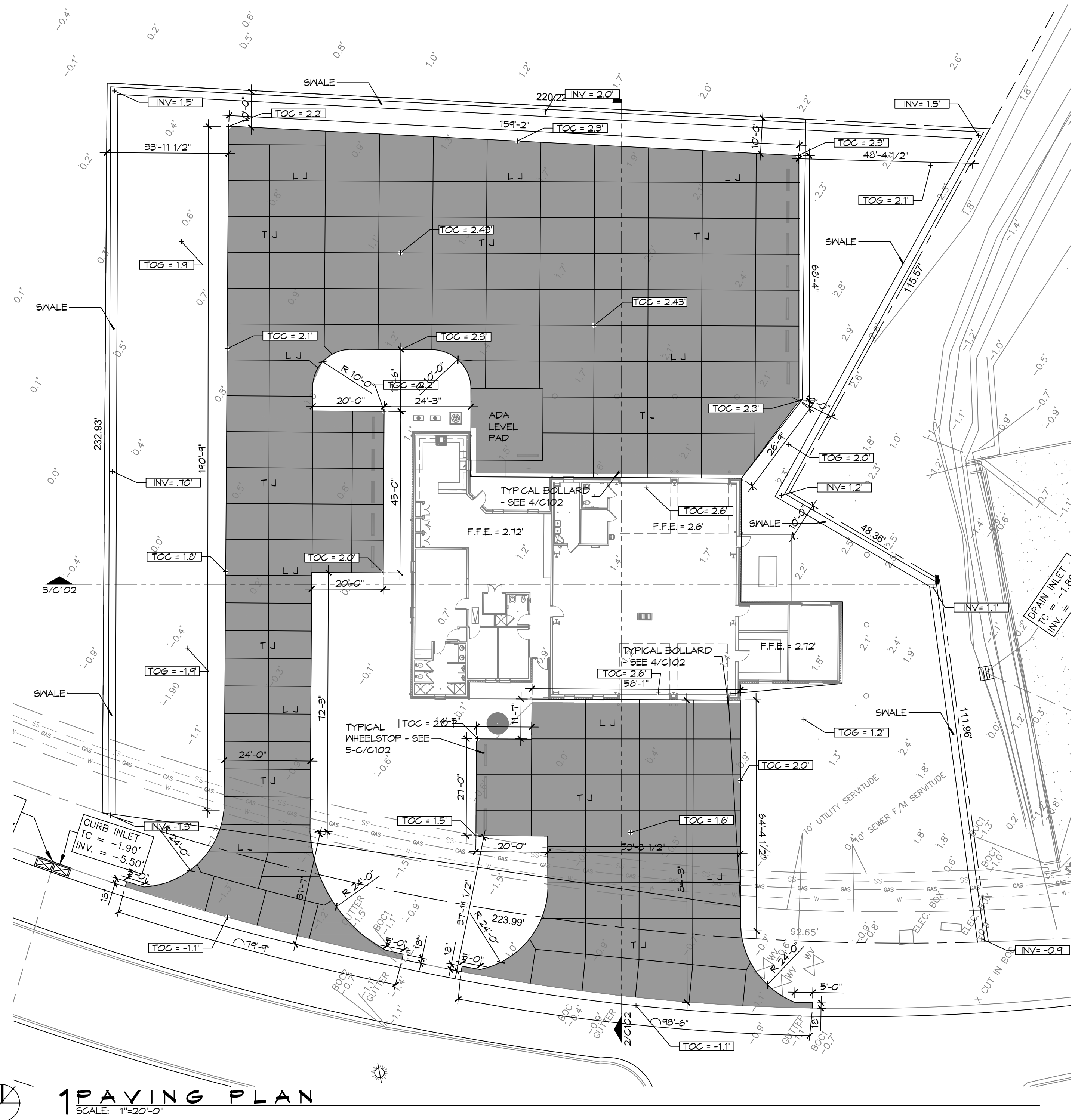
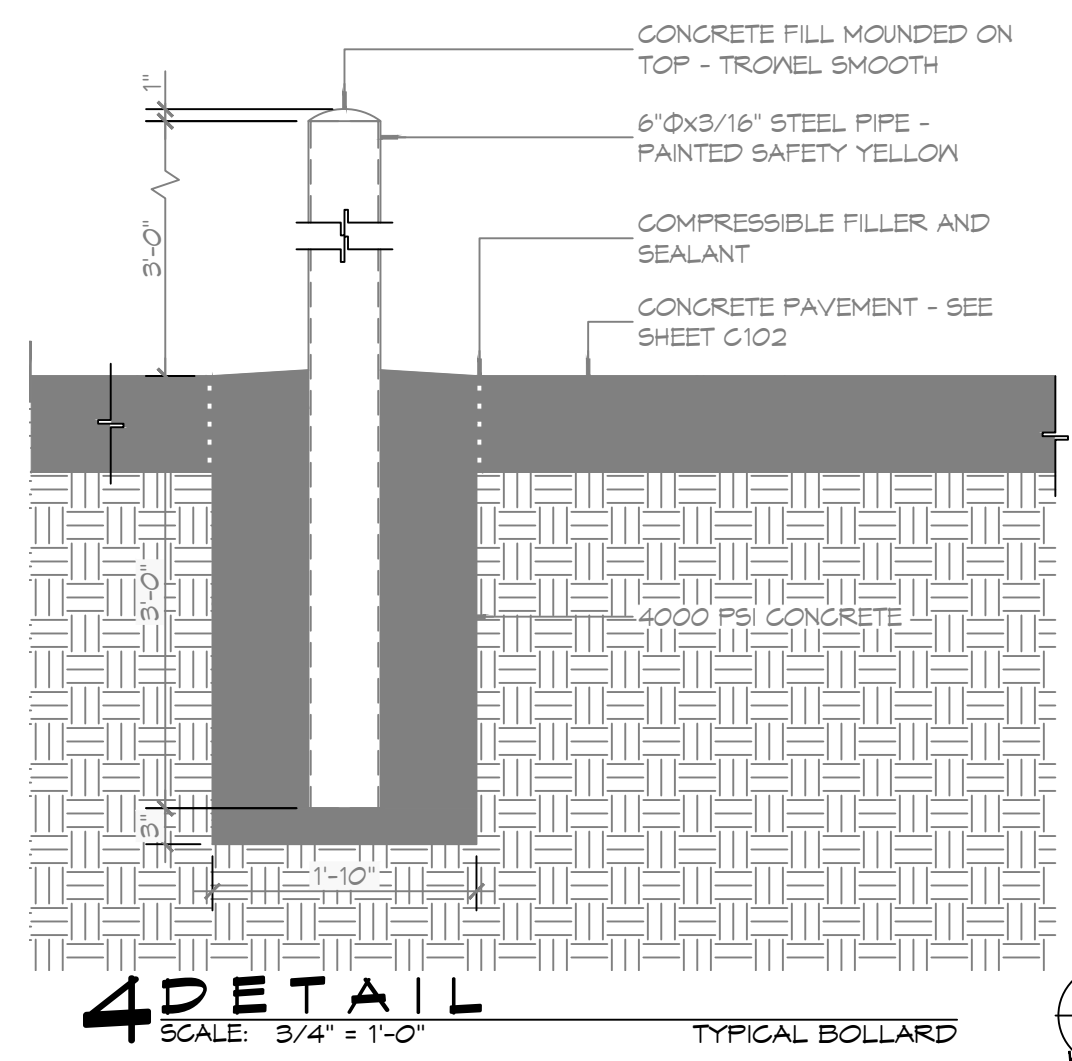

5 PAVING DETAIL

SCALE: N.T.S.

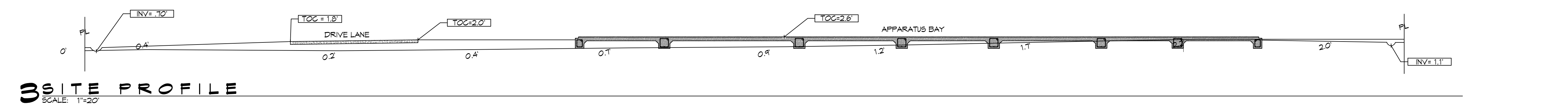
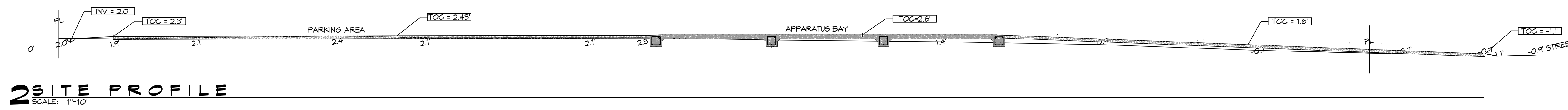

#	DESCRIPTION	DATE



NEW FIRE STATION #10
ST. TAMMANY FIRE PROTECTION DISTRICT NO. 1

246 LAKESHORE VISTA BLVD
SLIDELL, LA 70461

JOB No: 2519 DATE: 12-05-2015
DRAWN BY: CKD CHECKED BY: BAK

SHEET TITLE:
DETAIL SITE GRADING AND PAVING PLAN, PAVING DETAILS

DRAWING NUMBER:

C102

FILE NAME: C:\Users\dammon\OneDrive\Documents\Projects\C103\Site Utilities\DWG\Site Utilities.dwg PLOT DATE: 12/05/2025 PLOT TIME: 10:00 AM

2 DETAIL
SCALE: N.T.S.
SERVICE LATERAL DETAIL

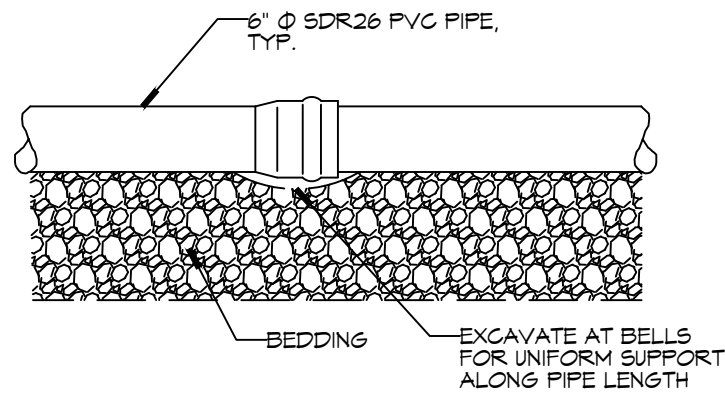

3 DETAIL
SCALE: N.T.S.
THROUGH FLOW CLEAN OUT DETAIL

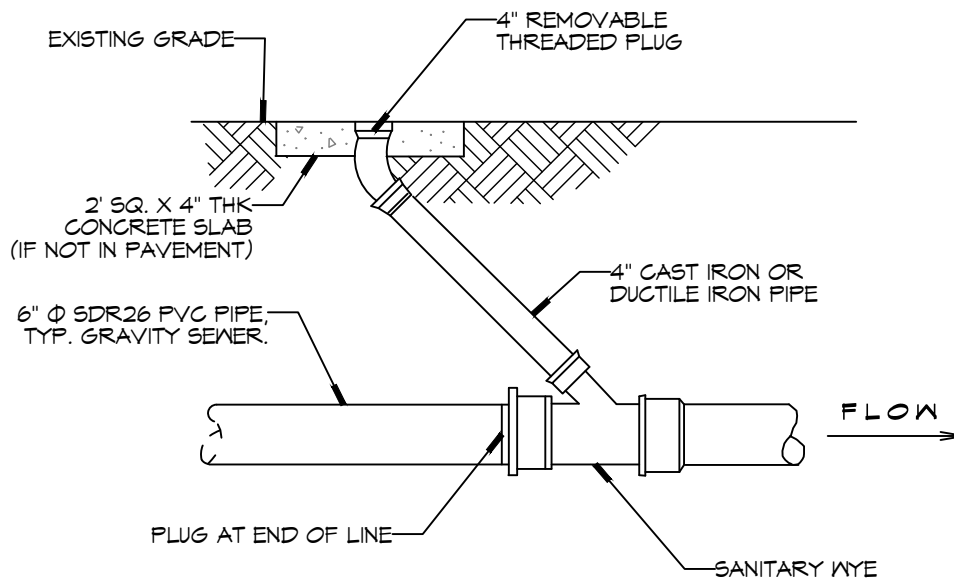

4 TYPICAL RISER DETAIL
SCALE: N.T.S.

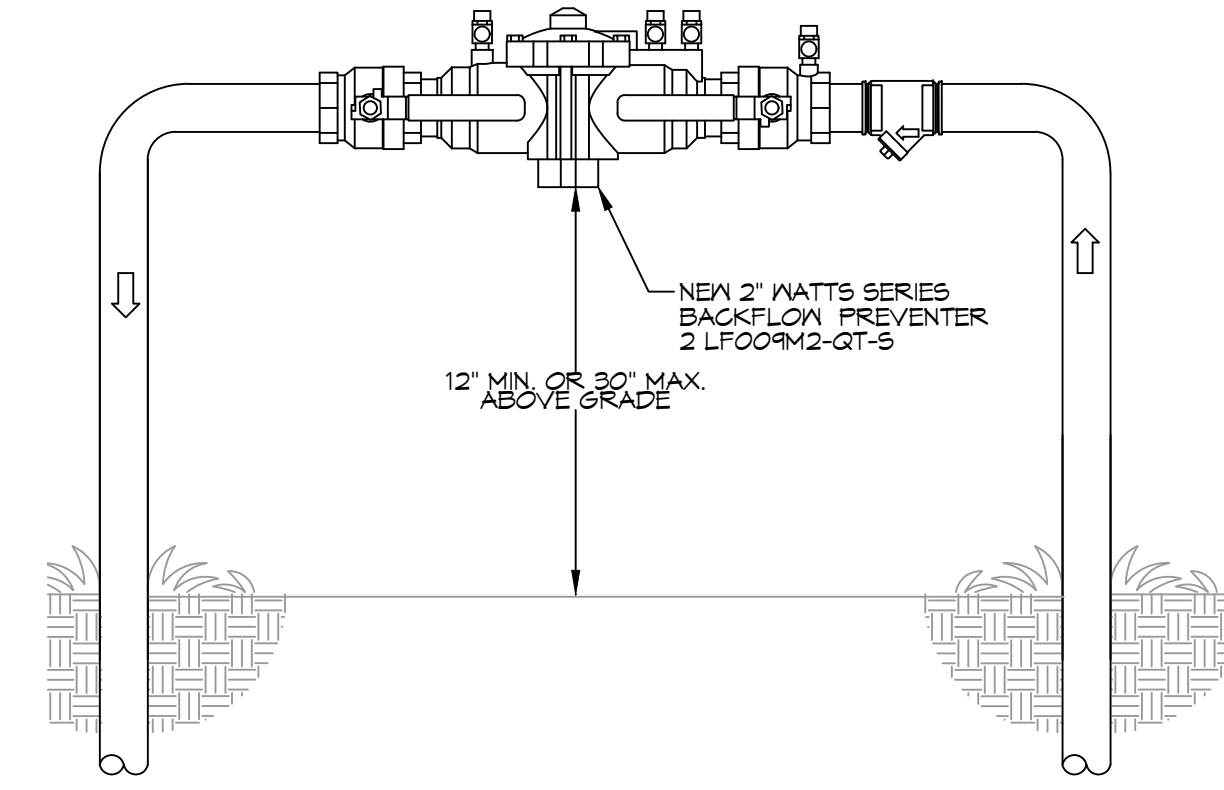

SITE LIGHTING

EXTERIOR LIGHTING SHALL BE SHADED OR INWARDLY DIRECTED IN SUCH A MANNER SO THAT NO DIRECT LIGHTING OR GLARE BE CAST BEYOND THE PROPERTY LINE. THE INTENSITY OF SUCH LIGHTING SHALL NOT EXCEED ONE FOOT CANDLE AS MEASURED AT THE ABUTTING PROPERTY LINE.

GENERAL SITE UTILITIES NOTES

- ALL CONSTRUCTION SHALL COMPLY WITH CONTRACT SPECIFICATIONS AND APPLICABLE LOCAL, STATE, AND FEDERAL STANDARDS AND REGULATIONS.
- CONSTRUCTION SHALL NOT INTERRUPT EXISTING UTILITIES.
- ALL DISTURBED GROUND SHALL BE RESTORED IN KIND TO A CONDITION EQUAL TO OR BETTER THAN ORIGINALLY FOUND.
- SOIL EROSION CONTROL SHALL BE IN ACCORDANCE WITH THESE DOCUMENTS.
- PROTECT EXISTING UTILITY LINES FROM DAMAGE. FOLLOW INDIVIDUAL UTILITY'S RECOMMENDATIONS FOR UTILITY LINE PROTECTION.
- CONTRACTOR SHALL IMMEDIATELY REPORT ALL DAMAGE TO UTILITY LINES TO BOTH UTILITY COMPANY AND ENGINEER.
- ALL DAMAGE CAUSED TO EXISTING UTILITY LINES BY CONTRACTOR'S OPERATIONS SHALL BE REPAIRED BY THE CONTRACTOR TO COMPLETE SATISFACTION OF THE UTILITY COMPANY AND ENGINEER.
- LOCATION OF EXISTING UTILITIES IS APPROXIMATE. CONTRACTOR SHALL FIELD VERIFY EXACT LOCATIONS.
- CONTRACTOR IS RESPONSIBLE FOR CUT AND CAP OF EXISTING UTILITIES PRIOR TO ANY DEMOLITION.
- CONTRACTOR SHALL CONTACT LOUISIANA ONE CALL PRIOR TO COMMENCEMENT OF SITE EXCAVATION.

SITE UTILITIES LEGEND

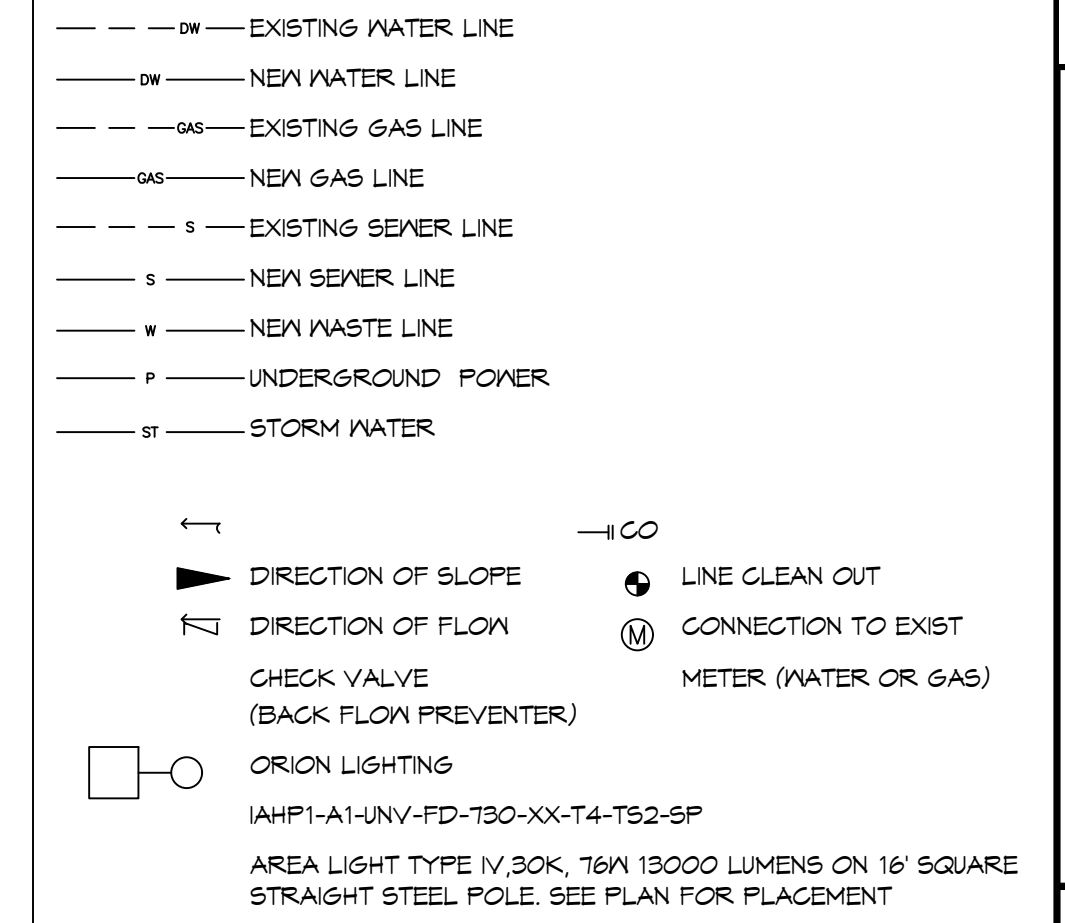

1 SITE UTILITIES PLAN
SCALE: 1" = 20'

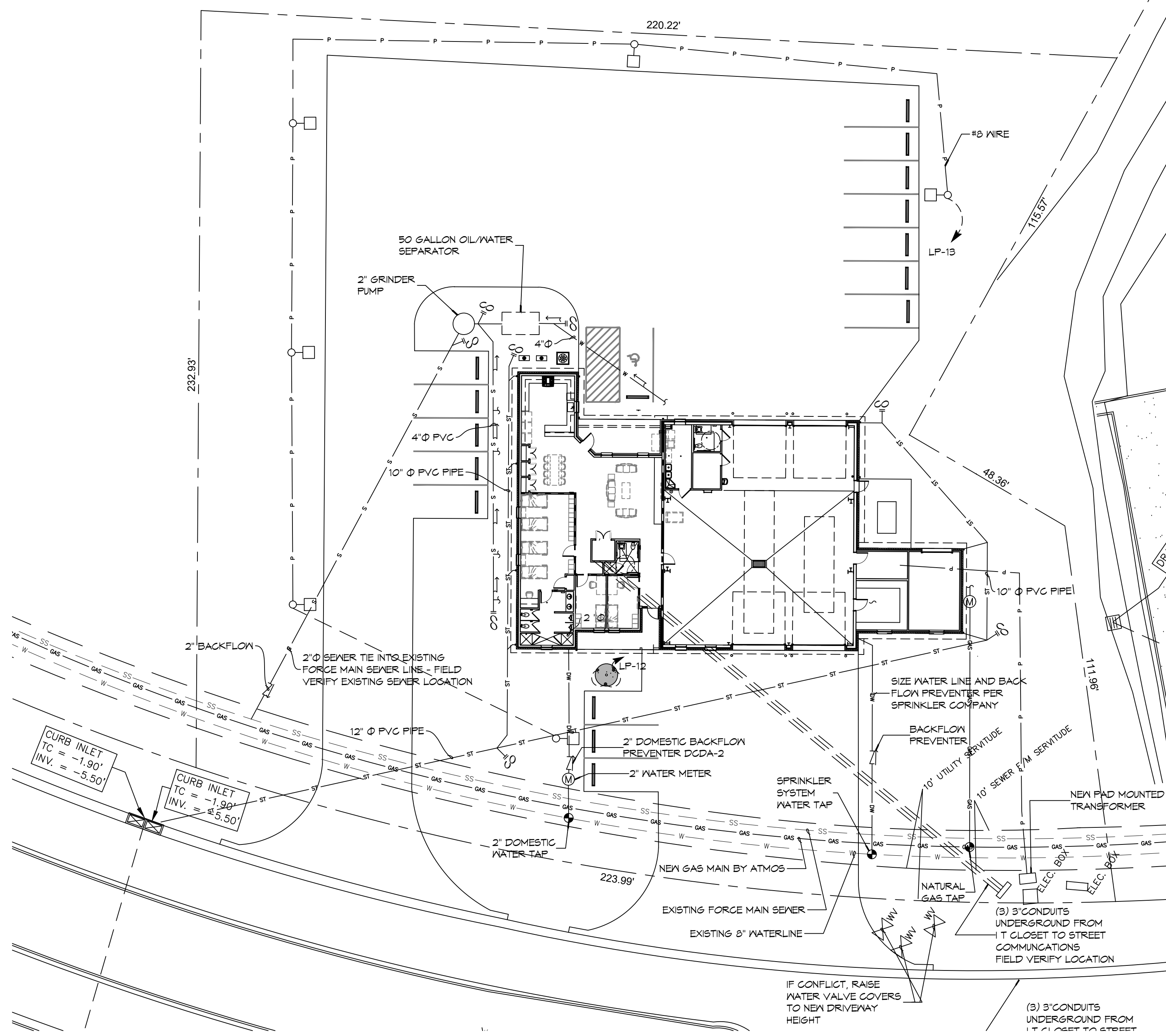

5 DETAIL
SCALE: N.T.S.
SEWER AND WATER SEPERATION

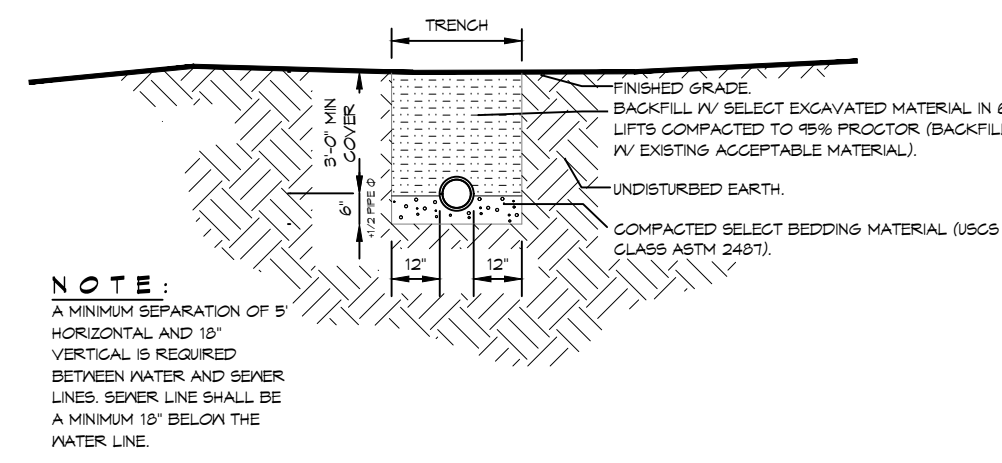

6 WATER SERVICE CONNECTION
SCALE: N.T.S.

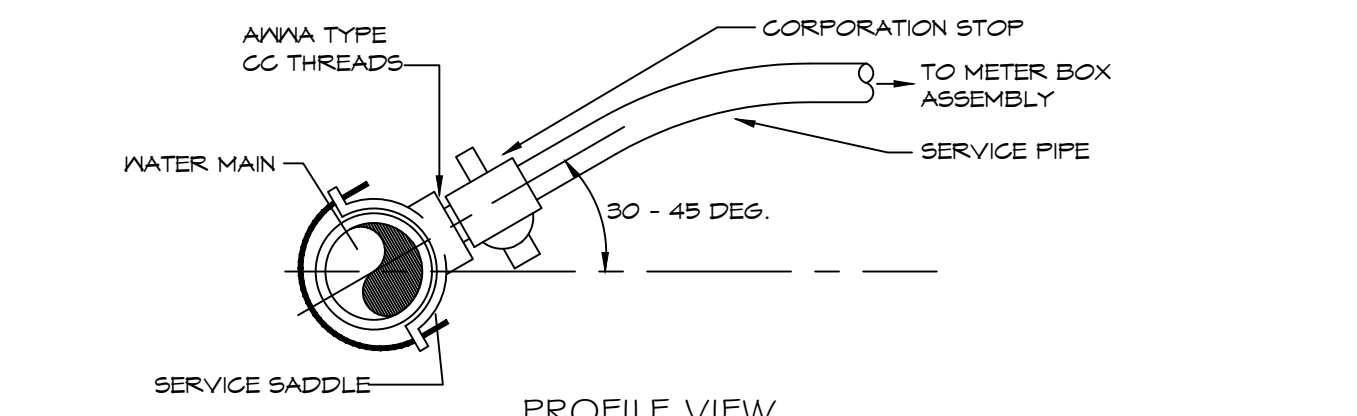

7 GRINDER PUMP
SCALE: N.T.S.

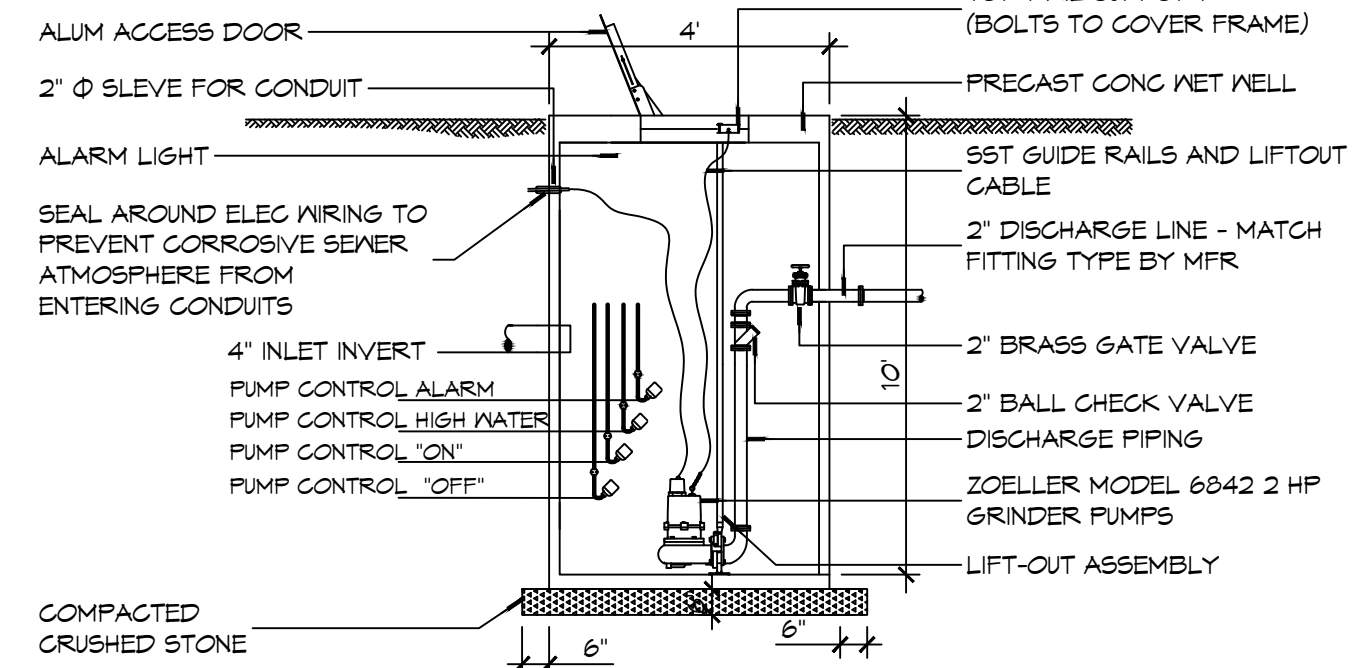

8 LIGHT POLE DETAIL
SCALE: N.T.S.

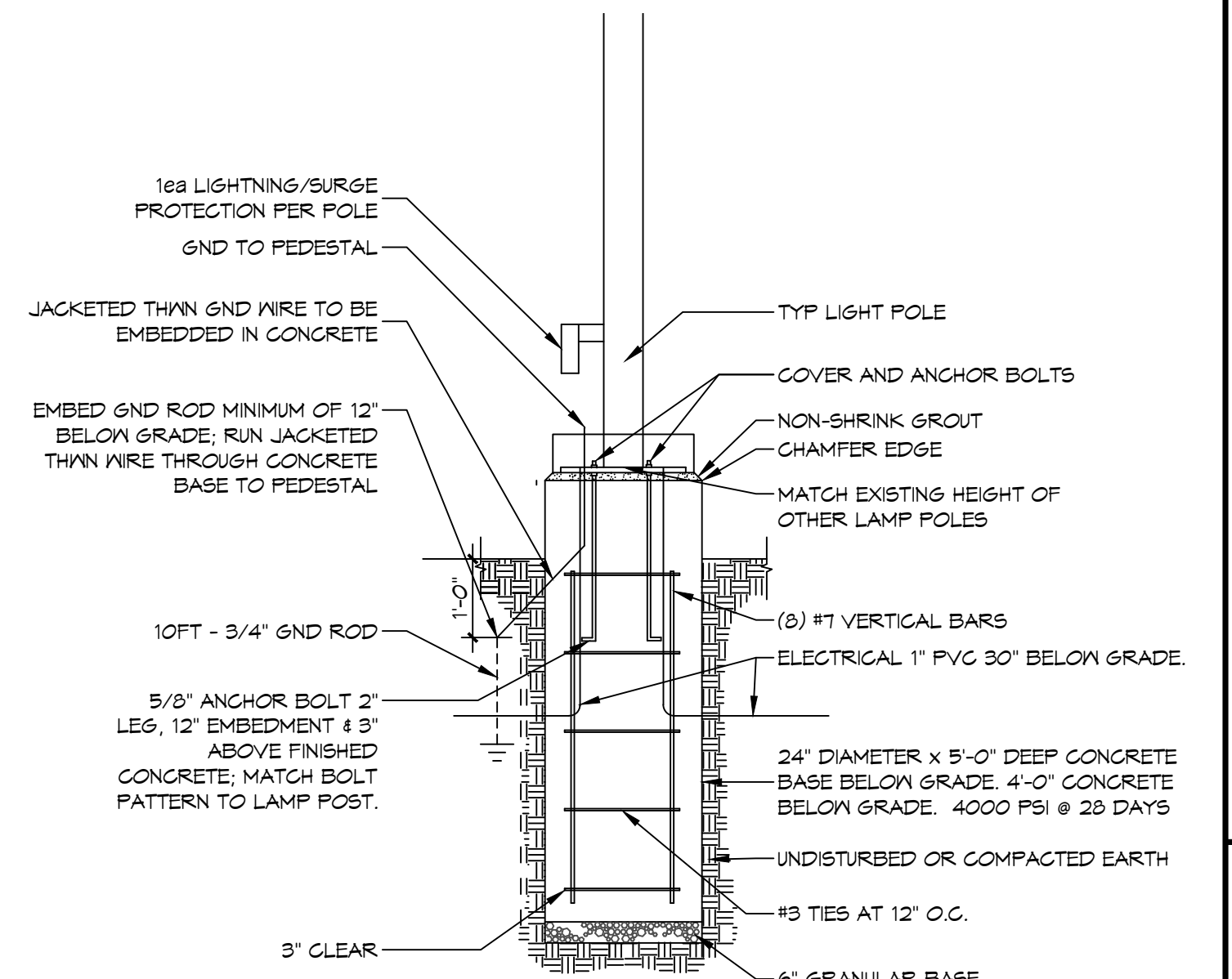

CONTACT FOR ATMOS ENERGY
Kathleen A DuFour
Account Representative
Atmos Energy Corporation
Louisiana Division
985-373-9111 Cell
kathleen.dufour@atmosenergy.com

CONTACT FOR MAGNOLIA WATER
Steve Ernst
Director, Louisiana Regulatory Relations
Email: sernst@swrgroup.com
M:(985) 640-1355

DAMMON ENGINEERING, INC.
LOUISIANA & MISSISSIPPI
www.dammonengineering.com
info@dammonengineering.com
PH: 985.649.5832
Chief Engineer: Brian Mistich, PE
554 Old Spanish Trail
Slidell, LA 70458

#	DESCRIPTION	DATE

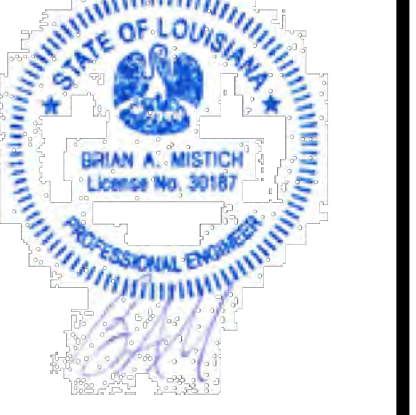

NEW FIRE STATION #10
ST. TAMMANY FIRE PROTECTION DISTRICT NO. 1

SHEET TITLE:
SITE PLAN - SITE UTILITIES AND DETAILS

DRAWING NUMBER:

C103

SHEET No: 7 of 31

GENERAL SITE DRAINAGE NOTES

1. DRAIN PIPE(S) ALONG AIRPORT MUST BE THE BELL AND SPIGOT TYPE WITH "O" RING RUBBER GASKETS. THE BELLS OF THE PIPES SHALL BE LAID UPSTREAM. ALL JOINTS SHALL BE WRAPPED WITH GEOTEXTILE FABRIC. ALL PIPES SHALL REQUIRE A 3" COMPACTED SAND OR LIMESTONE BASE.
2. REMOVE DEBRIS AND CLEAN BOTTOM OF DITCHES DOWN 6" IN DEPTH - REPLACE ANY BROKEN/CRUSHED PIPES OR CULVERTS WITH SAME SIZE AND TYPE.
3. DRAIN PIPE AND FITTINGS WITHIN PROPERTY LINE SHALL BE POLYVINYL CHLORIDE PLASTIC PIPE, MEETING CLASS 100 C-400 PVC.
4. ELEVATIONS SHOWN ARE M.S.L.
5. FIELD VERIFY ALL ELEVATIONS AND AND DRAINAGE SYSTEM PLACEMENT PRIOR TO START OF WORK.
6. PROVIDE VERTICAL ELBOW AT DOWNSPOUTS FOR CONNECTION TO SURFACE DRAINAGE WHERE INDICATED. ELBOW ID SHALL BE SIZED SUCH THAT THE DOWNSPOUT CAN BE INSERTED INTO THE PIPE OPENING.

SITE DRAINAGE LEGEND

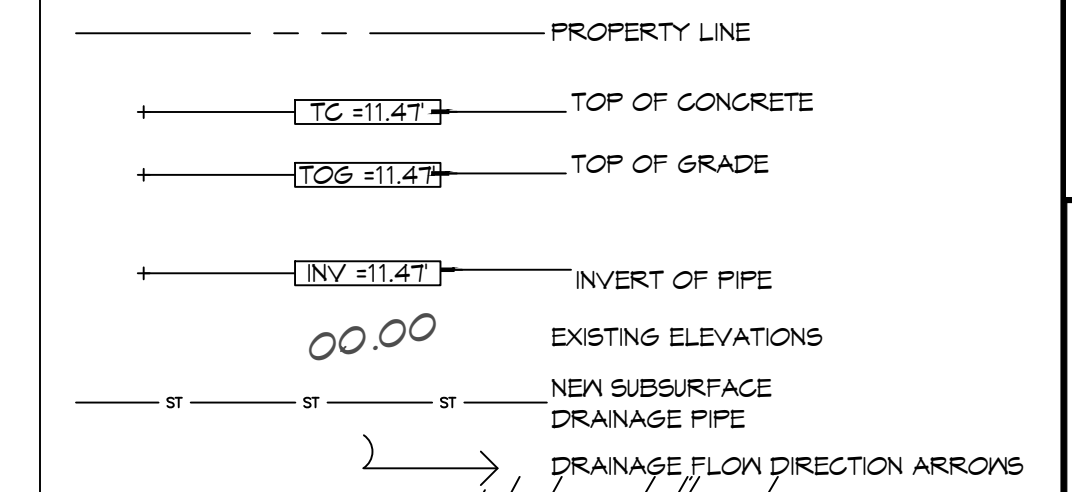

DAMMON ENGINEERING, INC.
 LOUISIANA & MISSISSIPPI
 Chief Engineer: Brian Mistich, PE
 554 Old Spanish Trail
 Slidell, LA 70458
 www.dammonengineering.com
 info@dammonengineering.com
 PH: 985.649.5832

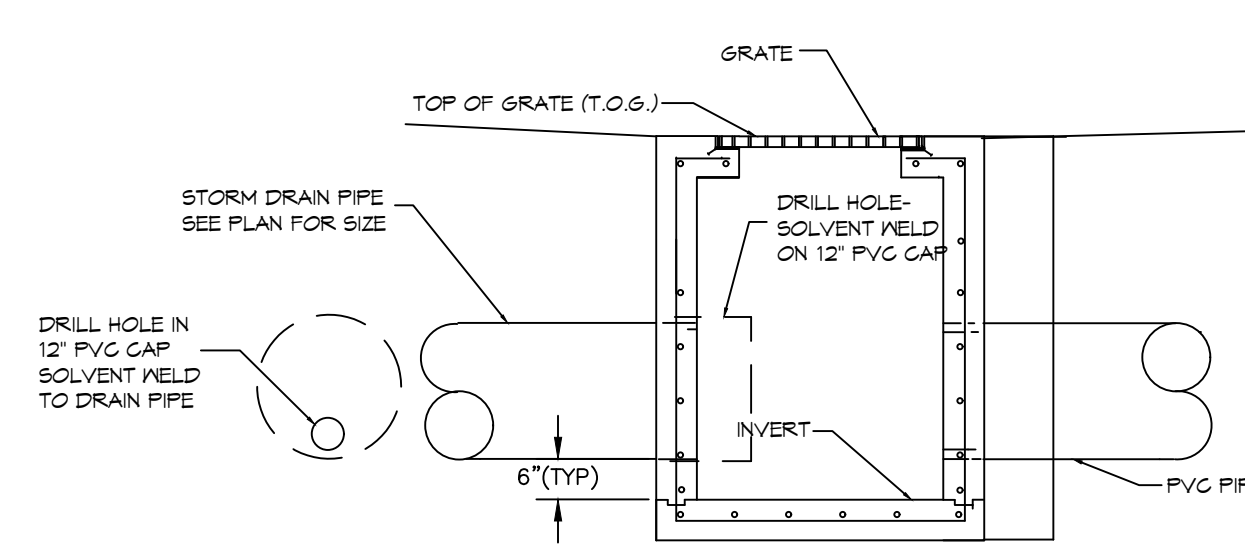

NOTE: SEE PLUMBING FIXTURE SCHEDULE DRAWING P103 FOR MODEL NUMBER OF CATCH BASIN.

7 DETAIL
SCALE: N.T.S. TYPICAL CATCH BASIN

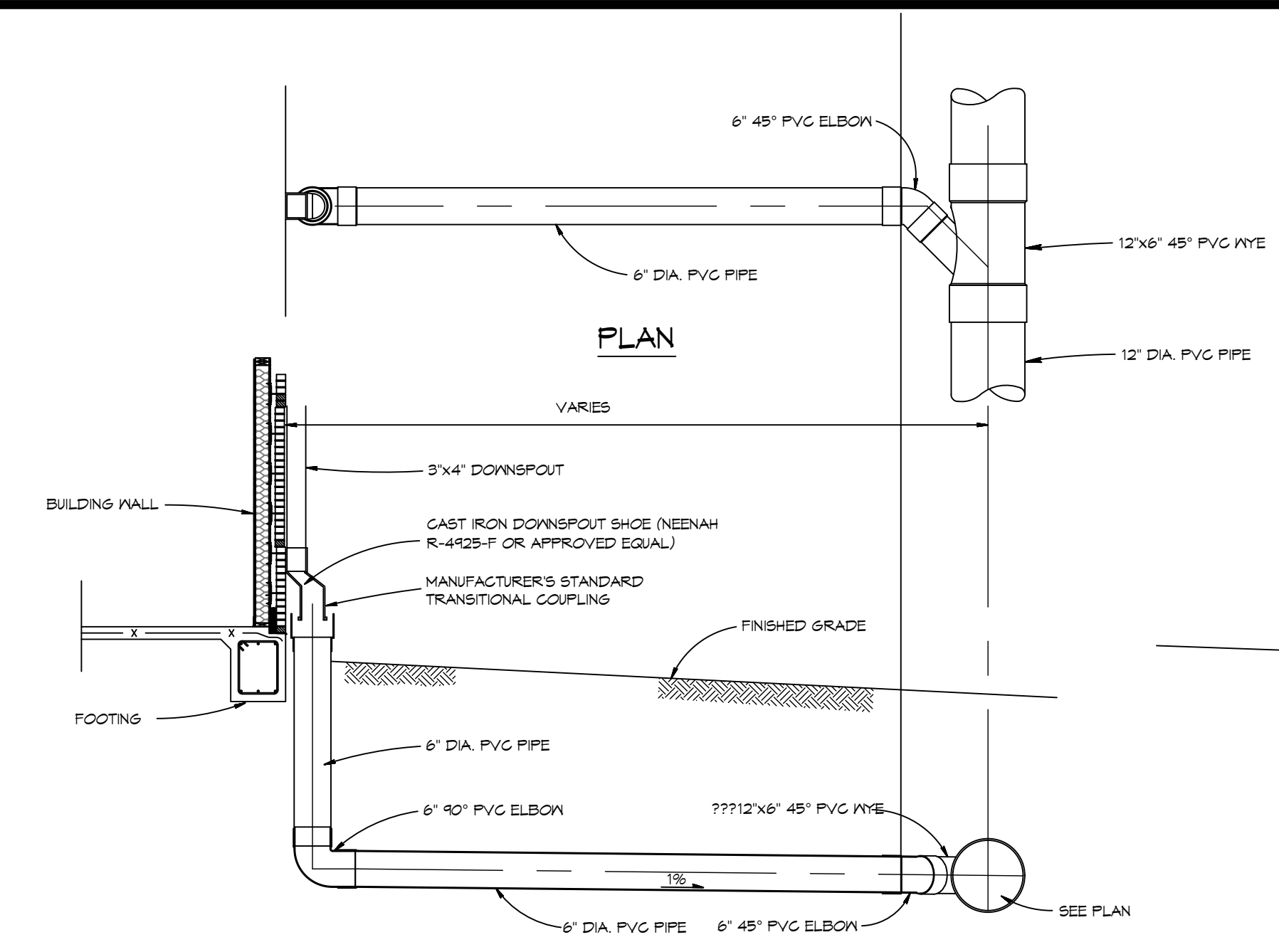

6 DETAIL
SCALE: 3/4" = 1'-0" TYPICAL ROOF DRAIN

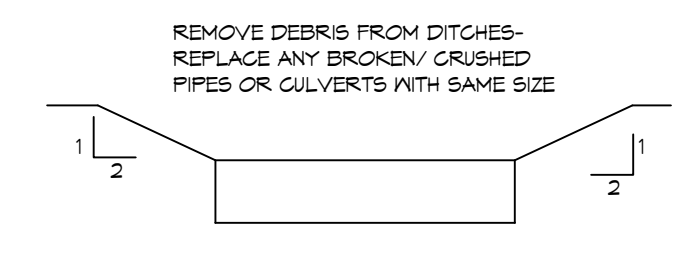

5 DETAIL
SCALE: N.T.S. TYPICAL SWALE

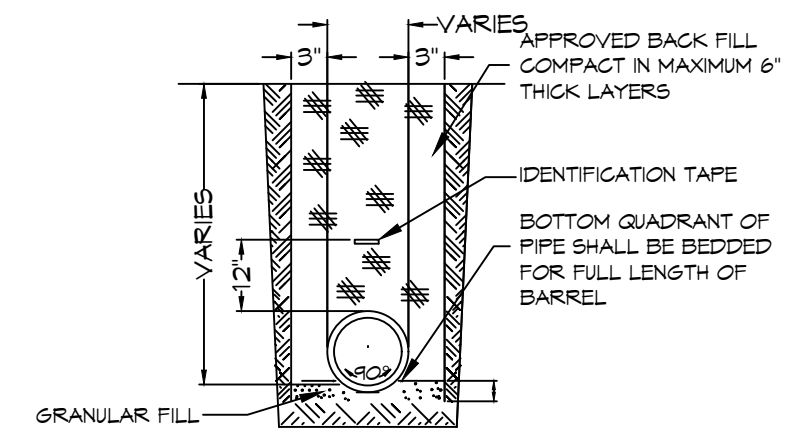

NOTES:
 1) DRAIN PIPE & FITTINGS SHALL BE POLYVINYL CHLORIDE PLASTIC PIPE, MEETING CLASS 100 C-400 PVC.
 2) ELEVATIONS SHOWN ARE M.S.L.

4 DETAIL
SCALE: N.T.S. TYPICAL DRAIN PIPE

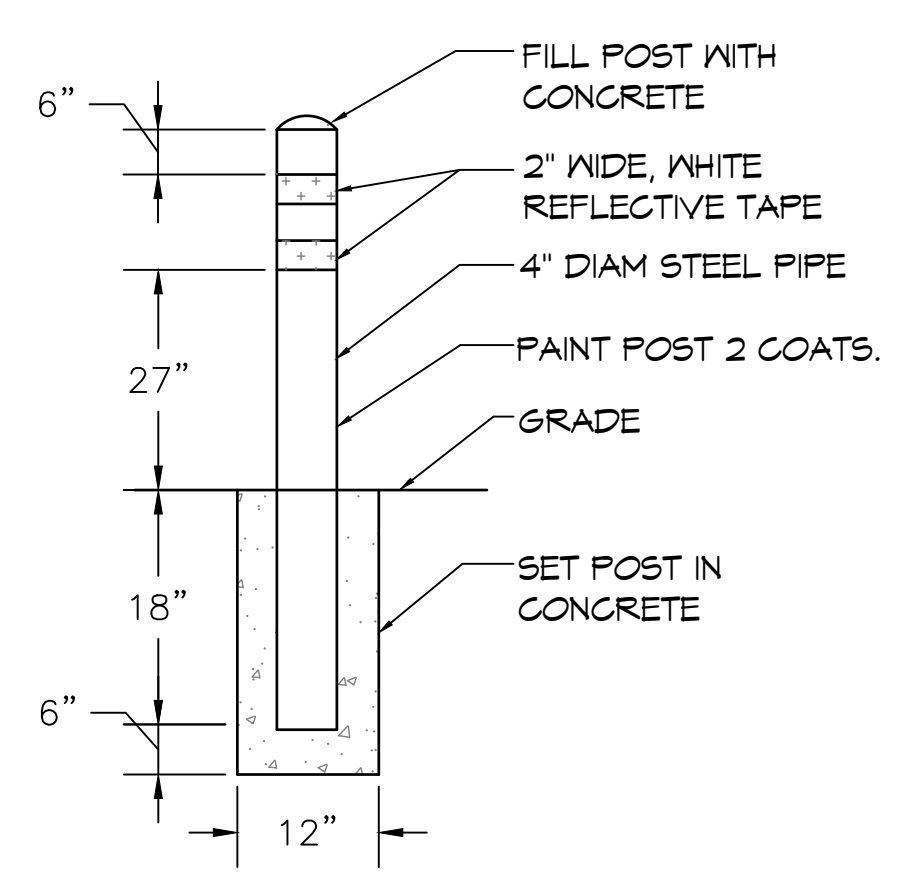

3 DETAIL
SCALE: 3/4" = 1'-0" TYP BOLLARD DETAIL

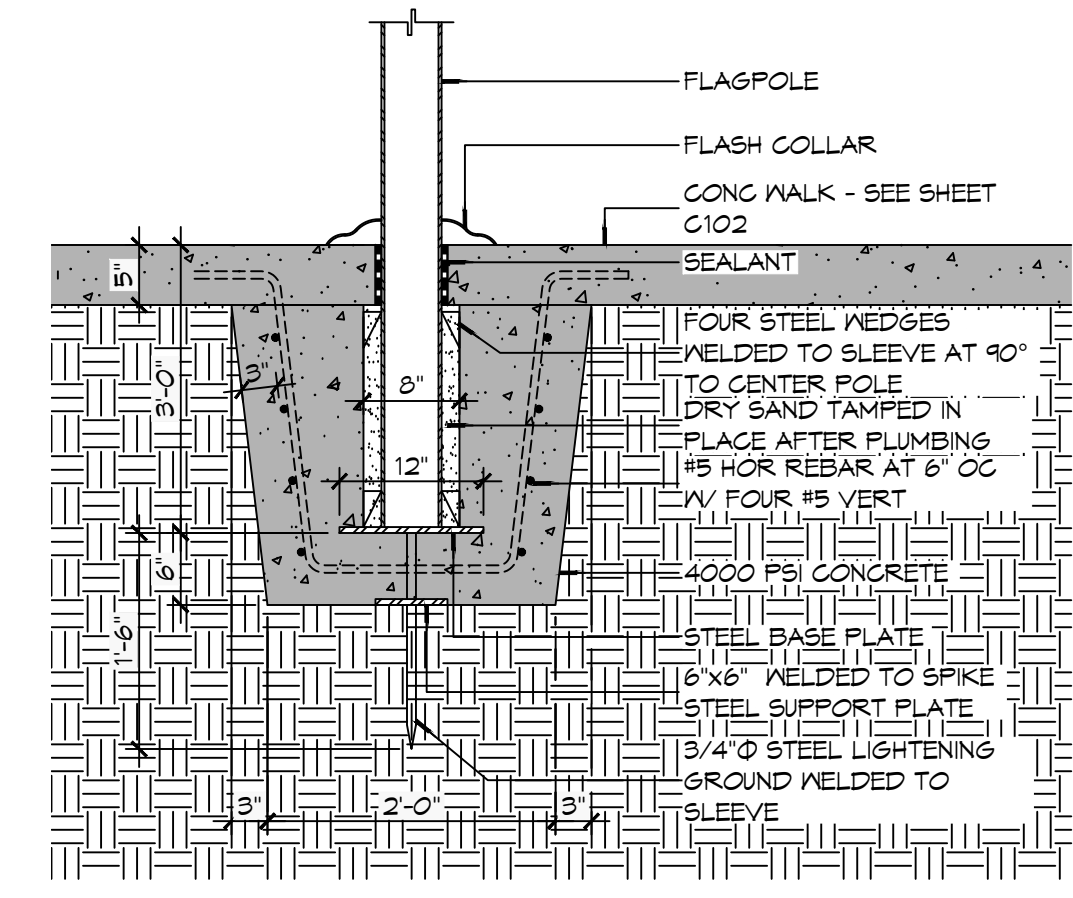

2 DETAIL
SCALE: 3/4" = 1'-0" FLAGPOLE FOUNDATION

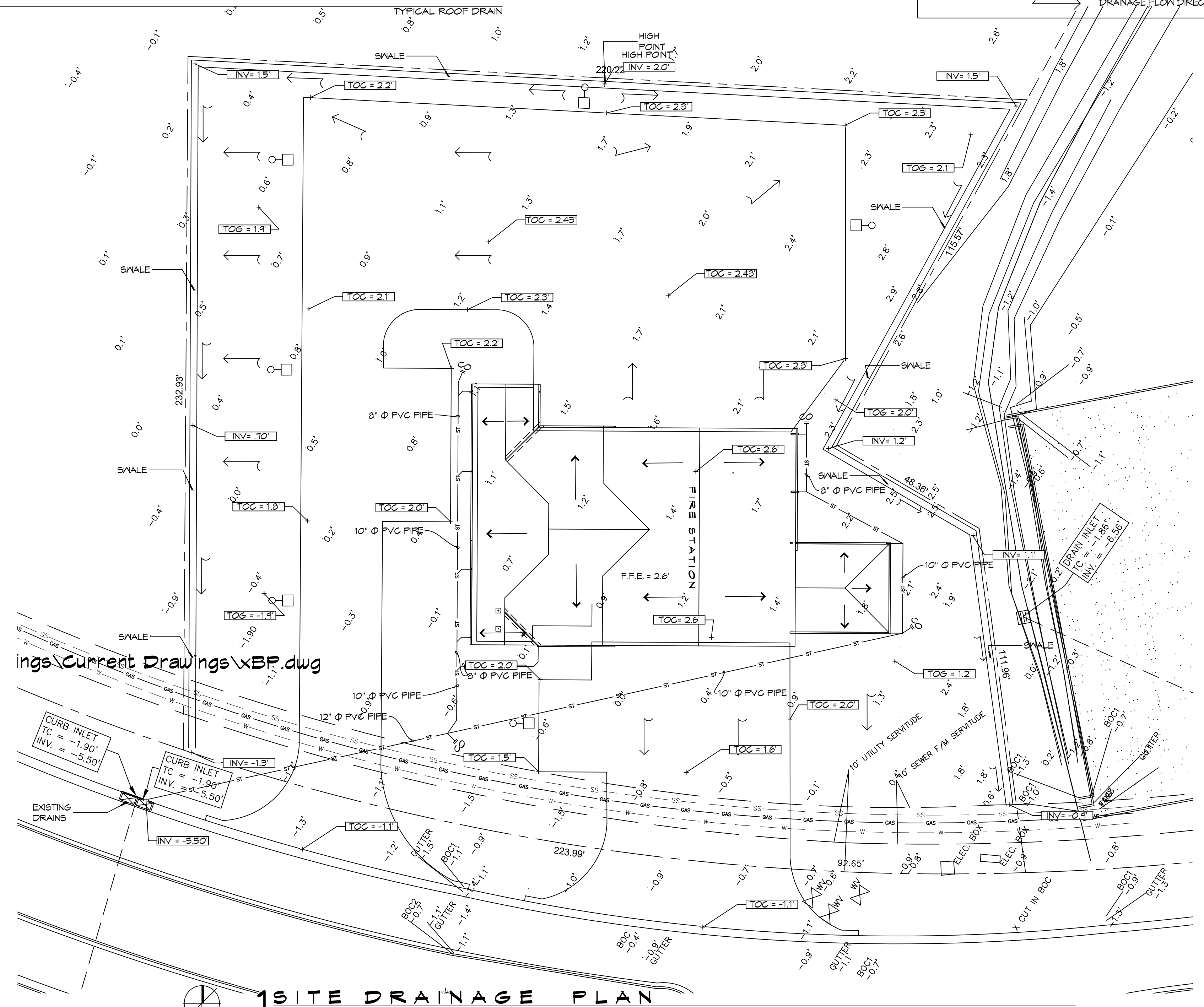

1 SITE DRAINAGE PLAN
SCALE: 1" = 20'

#	DESCRIPTION	DATE



NEW FIRE STATION #10
 ST. TAMMANY FIRE PROTECTION DISTRICT NO. 1
 2148 LAKESHORE VISTA BLVD
 SLIDELL, LA 70461
 JOB NO: 2519 DATE: 12-09-2025 DRAWN BY: BAK
 CHECKED BY: CKD

SHEET TITLE:
 SITE PLAN - DRAINAGE AND DETAILS
 DRAWING NUMBER:
C104
 SHEET No: 6 of 37

FILE NAME: A:\Projects\2018 - The Station (11/15/2018)\Station\Drawings\C105-03a - Erosion Control Plan & Details.dwg PLOT DATE: 12/05/2025 1:20:54 PM

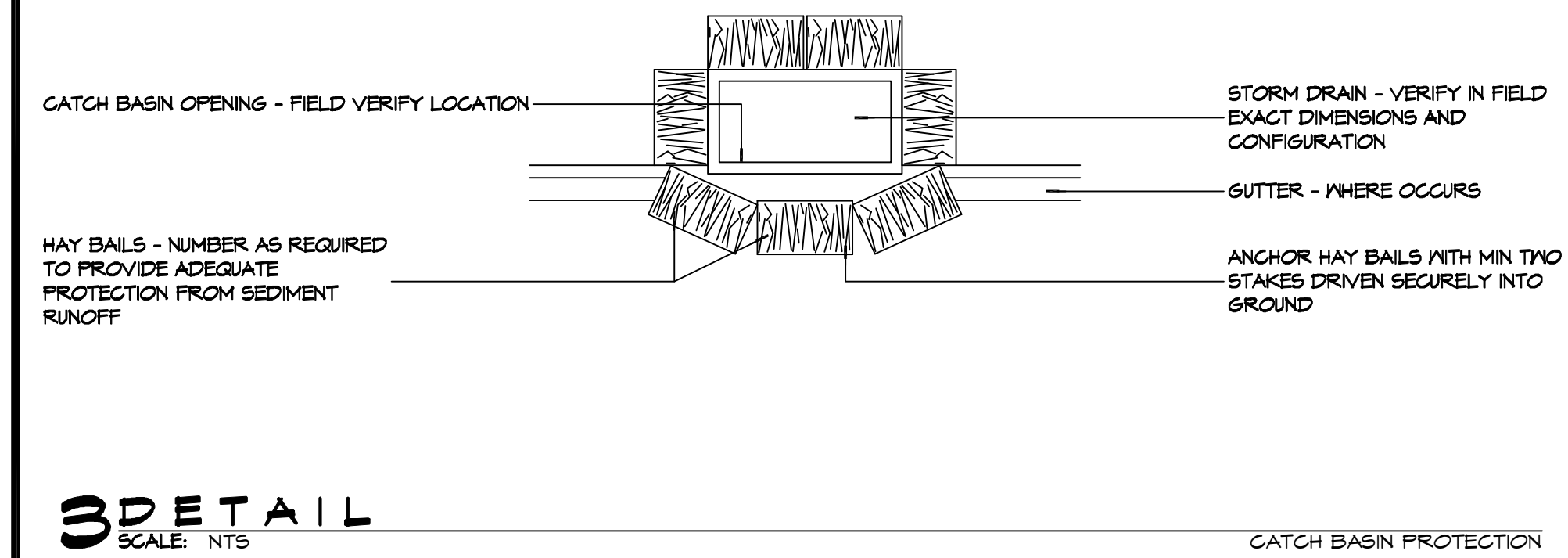
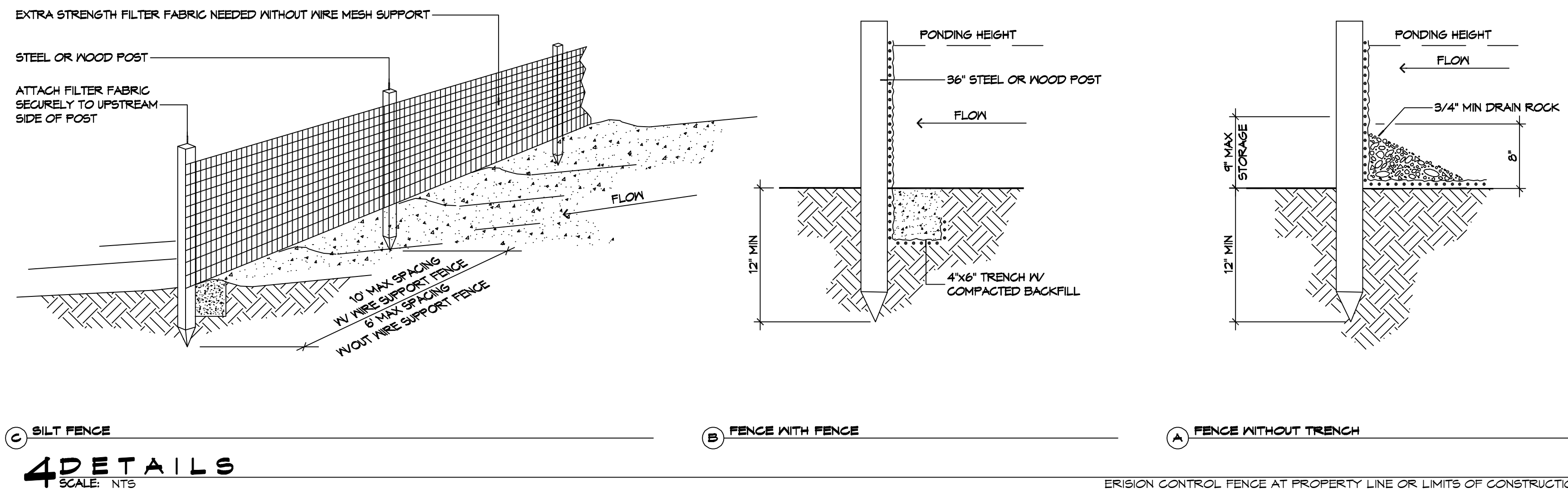

EROSION CONTROL FENCE NOTES:
THE TEMPORARY DROP INLET SILT TRAP IS TO BE USED IN SMALL DRAINAGE AREAS (LESS THAN 1 ACRE) WHERE THE STORM DRAIN IS FUNCTIONAL BEFORE THE AREA IS STABILIZED. THE TRAP CAN BE EITHER GEOTEXTILE FABRIC OR HAY BALES.

1. THE GEOTEXTILE FABRIC SHALL CONFORM TO SECTION 1019 (TYPE G) OF THE LA DOTD STANDARD SPECIFICATIONS.
2. WOODEN STAKES SUPPORTING THE FABRIC SHALL BE SPACED AROUND THE INLET AT A MAXIMUM SPACING OF 3 FEET.
3. THE HEIGHT OF THE FABRIC ABOVE THE INLET SHALL BE LIMITED TO 1'-6" AND THE BOTTOM OF THE FABRIC SHALL BE BURIED IN A TRENCH APPROXIMATELY 4" WIDE BY 4" DEEP. THE FABRIC SHALL BE STAPLED TO POST WITH 1/2" STAPLES.
4. THE TRAP SHOULD BE INSPECTED REGULARLY AND AFTER EACH STORM. THE SEDIMENT SHOULD BE REMOVED AND MAKE SURE EACH STAKE IS FIRMLY IN THE GROUND.

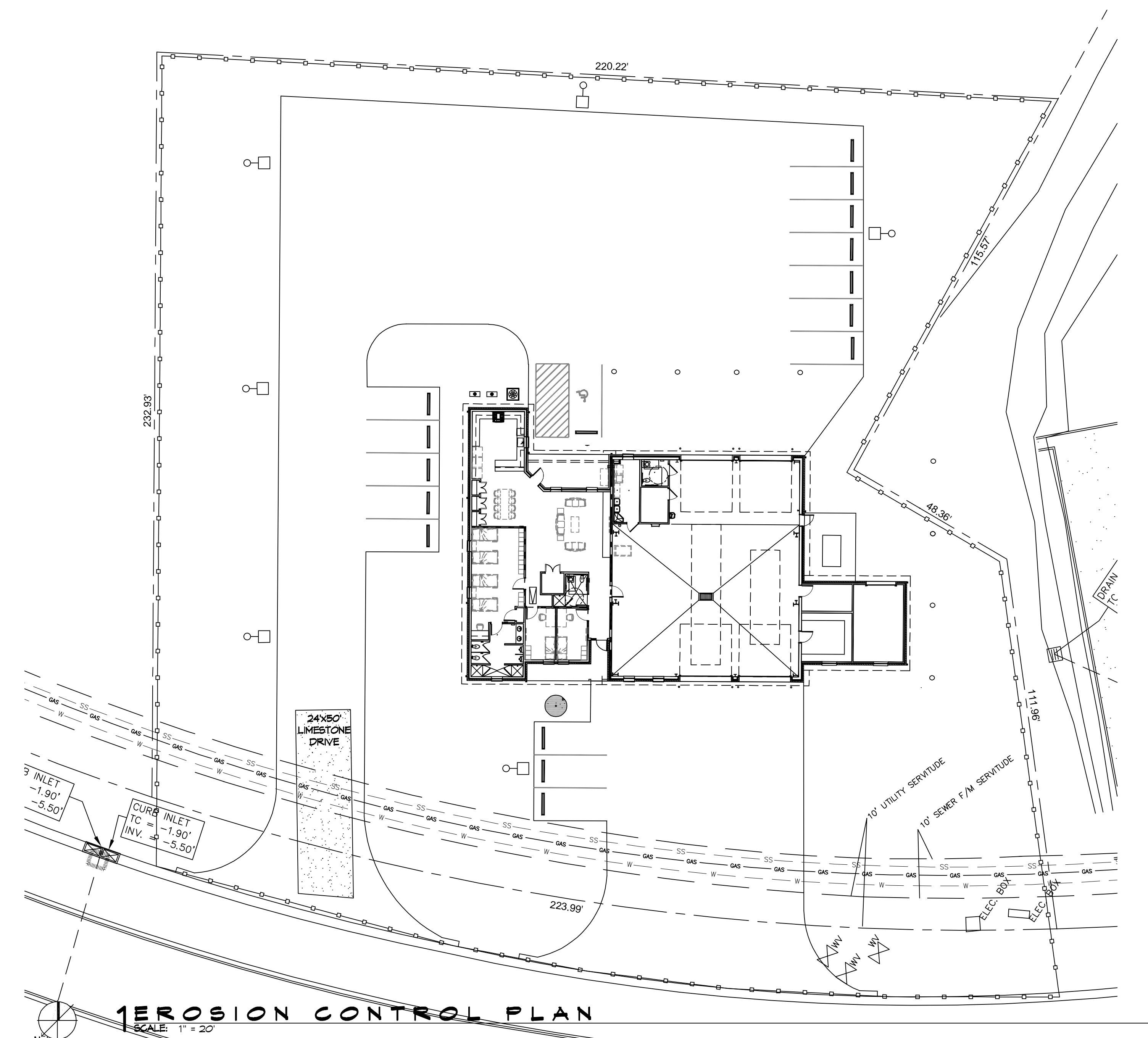
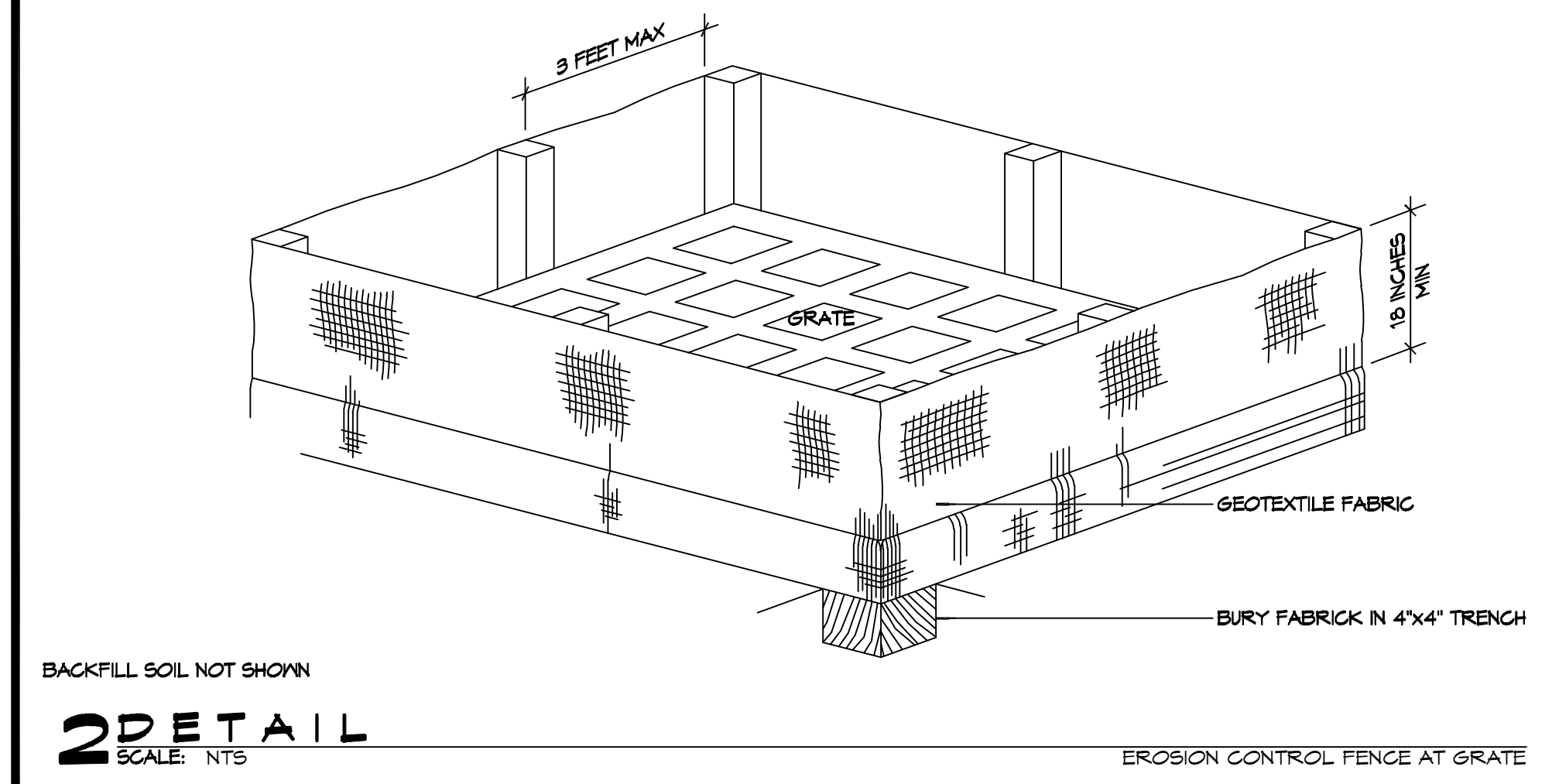

GENERAL EROSION CONTROL NOTES

1. ALL APPLICABLE EROSION AND SEDIMENT CONTROL PRACTICES SHALL BE IN PLACE PRIOR TO ANY GRADING OPERATION AND/OR INSTALLATION OF PROPOSED STRUCTURES OR UTILITIES.
2. SOIL EROSION AND SEDIMENT CONTROL PRACTICES ON THIS PLAN SHALL BE CONSTRUCTED IN ACCORDANCE WITH STANDARDS OF THE AUTHORITY HAVING JURISDICTION.
3. APPLICABLE EROSION AND SEDIMENT CONTROL PRACTICES SHALL BE LEFT IN PLACE UNTIL CONSTRUCTION IS COMPLETED AND/OR THE AREA IS STABILIZED.
4. THE CONTRACTOR SHALL PERFORM ALL WORK, FURNISH ALL MATERIALS, AND INSTALL ALL MEASURES REQUIRED TO REASONABLY CONTROL THE SOIL EROSION RESULTING FROM CONSTRUCTION OPERATIONS AND PREVENT EXCESSIVE FLOW OF SEDIMENT FROM THE CONSTRUCTION SITE.
5. ANY DISTURBED AREA THAT IS TO BE LEFT EXPOSED FOR MORE THAN THIRTY (30) DAYS AND NOT SUBJECT TO CONSTRUCTION TRAFFIC SHALL IMMEDIATELY RECEIVE A TEMPORARY SEEDING AND FERTILIZATION IN ACCORDANCE WITH THE AUTHORITY HAVING JURISDICTION'S STANDARDS.
6. THE SITE SHALL BE AT ALL TIMES BE GRADED AND MAINTAINED SUCH THAT ALL STORMWATER RUNOFF IS DIVERTED TO SOIL EROSION AND SEDIMENT CONTROL FACILITIES.
7. ALL CATCH BASIN INLETS SHALL BE PROTECTED IN ACCORDANCE WITH THESE PLANS.
8. ANY WORK WITHIN THE ROADWAY OR ADJACENT TO THE ROADWAY CAUSING AN INTERFERENCE TO VEHICULAR TRAFFIC MUST CONFORM TO THE REQUIREMENTS SET FORTH BY THE UNIFORM MANUAL OF TRAFFIC CONTROL DEVICES OF THE STATE OF LOUISIANA. THE CONTRACTOR MUST FURNISH ALL NECESSARY TRAFFIC SIGNS AND/OR BARRICADES AND MAINTAIN THEM DURING CONSTRUCTION ACTIVITY.

SILT FENCE INSTALLATION NOTES

1. THE BASE OF BOTH END POSTS MUST BE AT LEAST 2'-4" ABOVE THE TOP OF THE SILT FENCE FABRIC ON THE MIDDLE POSTS FOR DITCH CHECKS TO DRAIN PROPERLY. USE A HAND LEVEL OR STRING LEVEL, IF NECESSARY, TO MARK BASE POINTS BEFORE INSTALLATION.
2. INSTALL POSTS 3 - 4 FEET APART IN CRITICAL WATER RETENTION AREAS AND 6 - 7 FEET APART ON STANDARD APPLICATIONS.
3. INSTALL POSTS 24" DEEP ON THE DOWNSTREAM SIDE OF THE SILT FENCE, AND AS CLOSE AS POSSIBLE TO THE FABRIC, ENABLING POSTS TO SUPPORT THE FABRIC FROM UPSTREAM WATER PRESSURE.
4. INSTALL POSTS WITH THE NIPPLES FACING AWAY FROM THE SILT FENCE FABRIC.
5. ATTACH THE FABRIC TO EACH POST WITH THREE TIES, ALL SPACED WITHIN THE TOP 8" OF THE FABRIC. ATTACH EACH TIE DIAGONALLY 45° THROUGH THE FABRIC, WITH EACH PUNCTURE AT LEAST 1" VERTICALLY APART. ADDITIONALLY, EACH TIE SHOULD BE POSITIONED TO HANG ON A POST NIPPLE WHEN TIGHTENED TO PREVENT SAGGING.
6. WRAP APPROXIMATELY 6" OF FABRIC AROUND THE END POSTS AND SECURE WITH 3 TIES.
7. NO MORE THAN 24" OF A 36" FABRIC IS ALLOWED ABOVE GROUND LEVEL.
8. THE INSTALLATION SHOULD BE CHECKED AND CORRECTED FOR ANY DEVIATIONS BEFORE COMPACTION. USE A FLAT-BLADED SHOVEL TO TUCK FABRIC DEEPER INTO THE SILT IF NECESSARY.
9. COMPACTION IS VITALLY IMPORTANT FOR EFFECTIVE RESULTS. COMPACT THE SOIL IMMEDIATELY NEXT TO THE SILT FENCE FABRIC WITH THE FRONT WHEEL OF THE TRACTOR, SKID STEER, OR ROLLER EXERTING AT LEAST 60 PSI OF PRESSURE. COMPACT THE UPSTREAM SIDE FIRST, AND THEN EACH SIDE TWICE FOR A TOTAL OF FOUR TRIPS.
10. SILT FENCE SHALL BE PLACED ON SLOPE CONTOURS TO MAXIMIZE PONDING EFFICIENCY.
11. INSPECT AND REPAIR FENCE AFTER EACH STORM EVENT AND REMOVE SEDIMENT WHEN NECESSARY. NINE INCH MAXIMUM RECOMMENDED STORAGE HEIGHT.
12. REMOVED SEDIMENT SHALL BE DEPOSITED TO AN AREA THAT WILL NOT CONTRIBUTE SEDIMENT OFF-SITE AND CAN BE PERMANENTLY STABILIZED.

EROSION CONTROL LEGEND



DAMMON ENGINEERING, INC.
LOUISIANA & MISSISSIPPI

Chief Engineer: Brian Mistich, PE
554 Old Spanish Trail
Slidell, LA 70488
www.dammonengineering.com
info@dammonengineering.com
PH: 985.649.5332

#	DESCRIPTION	DATE

SEAL:

BRIAN A. MISTICH
LOUISIANA No. 30187
PROFESSIONAL ENGINEER

NEW FIRE STATION #10
ST. TAMMANY FIRE PROTECTION DISTRICT NO. 1

246 LAKESHORE VISTA BLVD
SLIDELL, LA 70461

JOB NO: 2519 DATE: 12-05-2025
DRAWN BY: CKD CHECKED BY: BAW

SHEET TITLE:
SITE PLAN - EROSION CONTROL AND DETAILS

DRAWING NUMBER:
C105

SHEET No: 9 of 37

FILE NAME: C:\Users\dammon\Documents\2025 - Fire Station #10\2025 Fire Station #10\2025 Fire Station #10.dwg
 PLOT DATE: 12/25/2025
 PLOT TIME: 10:00:00 AM
 PLOT SCALE: 1"=30'-0"
 PLOT SHEET: 1 of 3
 PLOT BY: BAW

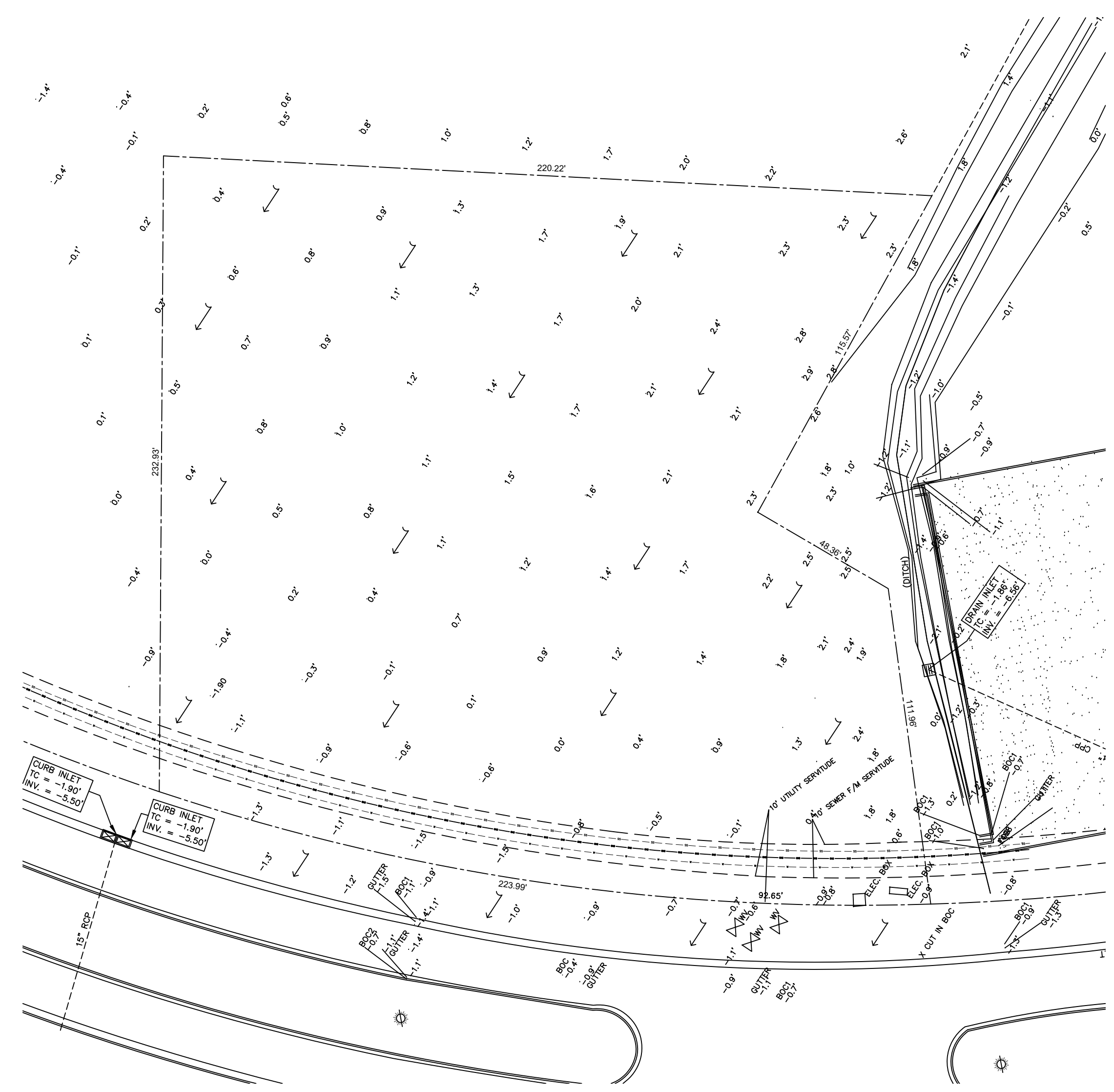

1 PRE DEVELOPMENT
 SCALE: 1" = 30'-0"

PRE HARD & GREEN SPACE

EXISTING AREA - 1.154 ACRES = 50,491 SQ. FT.
 GREEN AREA = 50,491 SQ. FT.

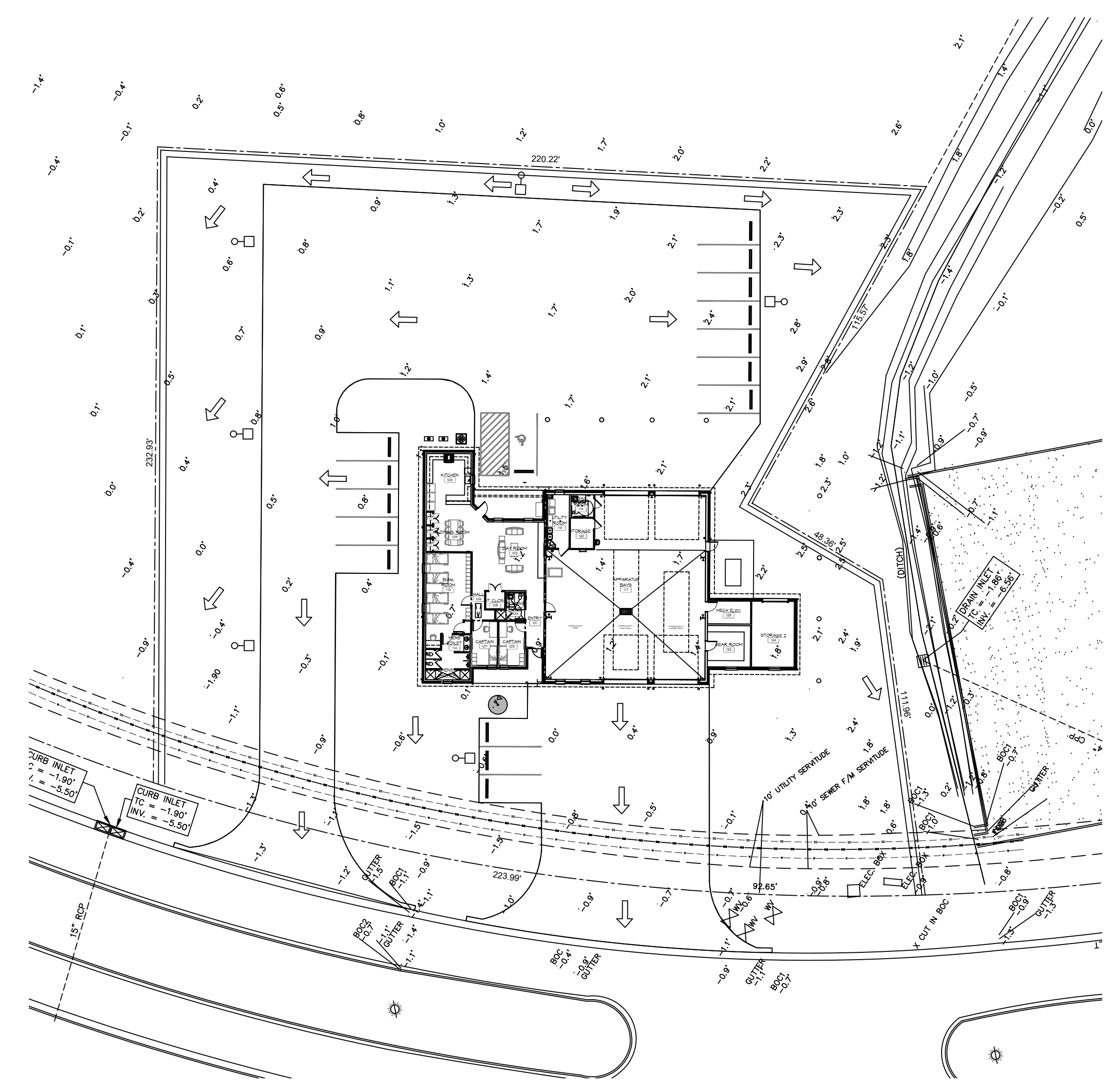

2 POST DEVELOPMENT
 SCALE: 1" = 30'-0"

POST HARD & GREEN SPACE

EXISTING AREA - 1.154 ACRES = 50,491 SQ. FT.
 BUILDING AREA = 6,526 SQ. FT.
 CONCRETE PAVING AREA = 22,885 SQ. FT.
 GREEN AREA = 21,080 SQ. FT.

NO ADVERSE IMPACT TO ADJACENT PROPERTIES
 AREA RESULTS IN A NEGLIGIBLE CHANGE FROM THE EXISTING RUNOFF COEFFICIENT (C) AND RATE OF RUNOFF AND DRAINAGE PATTERNS ARE TO REMAIN THE SAME.

PRE & POST WATER FLOW

PRE DEVELOPMENT DRAINAGE FLOW
 POST DEVELOPMENT DRAINAGE FLOW

DAMMON

ENGINEERING, INC.

LOUISIANA & MISSISSIPPI

Chief Engineer: Brian Mistich, PE
 554 Old Spanish Trail
 Slidell, LA 70458
 www.dammonengineering.com
 info@dammonengineering.com
 PH: 985.649.3832

#	DATE



NEW FIRE STATION #10
ST. TAMMANY FIRE PROTECTION
DISTRICT NO. 1

2745 LAKESHORE VISTA BLVD
 SLIDELL, LA 70461

JOB No: 2516 | DATE: 12-05-2025
 DRAWN BY: BAW | CHECKED BY: CKD

SHEET TITLE:
PRE AND POST DEVELOPMENT

DRAWING NUMBER:
C106

SHEET No: 10 of 37

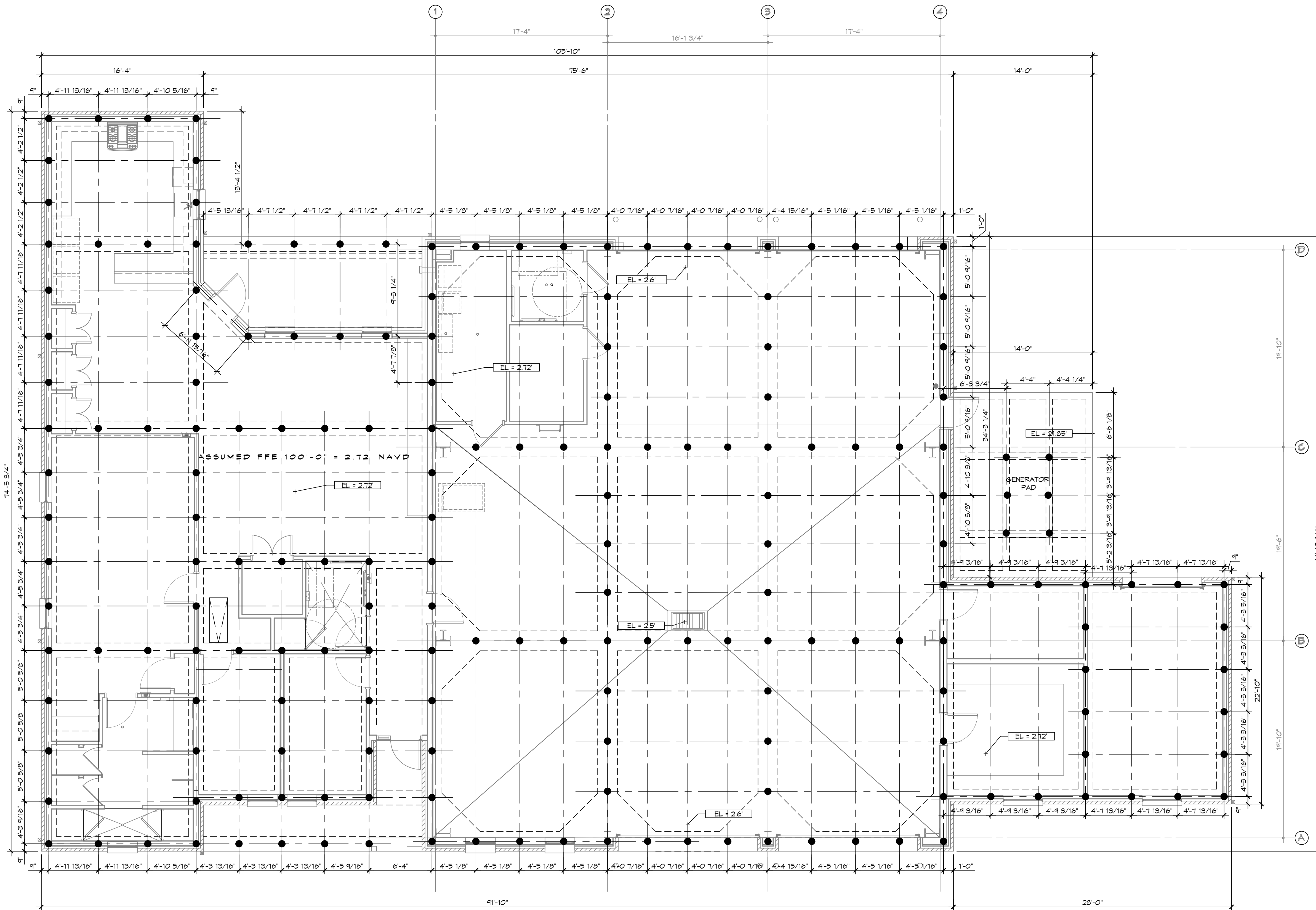

PILING NOTES

1. PILES ARE TO BE 30 FT. IN LENGTH WITH A 6 INCH TIP AND 6" BUTT. DRIVEN TO REFUSAL.
2. ALL PILES SHALL BE PRESSURE-TREATED ROUND TIMBER PILES CONFORMING TO ASTM D25.
3. DESIGN LOAD = 5 TONS PER PILE.
4. NO FIELD SUPERVISION OR INSPECTION PROVIDED UNDER THIS SEAL UNLESS OTHERWISE NOTED.
5. PILE LAYOUT MAY BE MODIFIED DUE TO ACTUAL DRIVING CONDITIONS. ENGINEER TO BE NOTIFIED ON ANY MODIFICATION.
6. A PILE BLOW COUNT LOG OF ALL PILES IS TO BE SUBMITTED TO THE ENGINEER OF RECORD. FAILURE TO SUBMIT SAID LOG WILL RELEASE THE ENGINEER OF ALL RESPONSIBILITY.
7. CONTRACTOR IS RESPONSIBLE FOR THE COMPARISON & VERIFICATION OF PILE LAYOUT DIMENSIONS WITH MOST RECENT ARCHITECTURAL DRAWINGS, ASSURING THAT PILES DO FALL WITHIN LIMITS OF THE DESIGN.
8. USE DROP HAMMER OR SINGLE ACTING AIR HAMMER DELIVERING 1,500 FT.-LBS OF ENERGY PER BLOW. RAM HEIGHT OF DROP HAMMER SHALL NOT EXCEED 2,500 TO 3,000 LBS AND THE DROP SHOULD NOT EXCEED 3 FT., AT MINIMUM OF 25 BLOWS PER FOOT. IF THE DROP EXCEEDS 3 FT., CONTACT ENGINEER FOR INSTRUCTIONS.
9. FIELD VERIFY DIMENSIONS AGAINST THE ARCHITECTURAL DRAWINGS.

PILING COUNT

189 PILING COUNT

DAMMON
ENGINEERING, INC.
LOUISIANA & MISSISSIPPI

Chief Engineer: Brian Mistich, PE
554 Old Spanish Trail
Slidell, LA 70458
www.dammonengineering.com
info@dammonengineering.com
PH: 985.649.5832

#	DESCRIPTION	DATE



**NEW FIRE STATION #10
ST. TAMMANY FIRE PROTECTION
DISTRICT NO. 1**

248 LAKESHORE VISTA BLVD
SLIDELL, LA 70461
JOB No: 2518 DATE: 12-09-2025
DRAWN BY: CKD CHECKED BY: BAK

SHEET TITLE:
PILING GENERAL
ARRANGEMENT

DRAWING NUMBER:
PGA1

SHEET No: 11 of 37

1 PILING GENERAL ARRANGEMENT
SCALE: 3/16" = 1'-0"

FILE NAME: J:\Projects\2023\230125102 - Fire Station #10\Drawings\230125102 - Ceiling Framing Plan & Details.dwg PLOT DATE: 2023-09-20 10:53:45

DESIGN CRITERIA

THE CONSTRUCTION FOR SAID RESIDENCE, WHERE BASIC WIND SPEED IS 140 MILES PER HOUR, WIND EXPOSURE ZONE C, IS DESIGNED IN ACCORDANCE WITH AMERICAN FOREST AND PAPER ASSOCIATION (AF&PA) WOOD FRAME CONSTRUCTION MANUAL FOR ONE AND TWO FAMILY DWELLINGS (WFCM) 2001 EDITION AS WELL AS THE INTERNATIONAL RESIDENTIAL CODE (IRC) 2021 EDITION.

GENERAL CEILING FRAMING NOTES

1. REFER TO SHEET S601 FOR TYPICAL CONNECTION DETAILS AND SCHEDULES.
2. PROVIDE CEILING FRAMING AT ALL GYPSUM BOARD CEILINGS AND SOFFITS SHOWN.
3. ALL CEILING JOISTS SHALL BE SPACED AT 16 INCHES OC UNLESS NOTED OTHERWISE.
4. PROVIDE DOUBLE JOISTS AT SIDES OF FRAMED OPENINGS AND AT CHANGES IN FRAMING DIRECTION UNLESS MORE STRINGENT FRAMING IS SHOWN.
5. CONTRACTOR SHALL COORDINATE JOIST LAYOUT WITH LIGHTS, VENTS, ACCESS OPENINGS, AND OTHER CEILING PENETRATIONS AS REQUIRED.
6. PROVIDE FRAMED OPENING WHERE NECESSARY TO ACCOMMODATE RECESSED LIGHT FIXTURES. WHERE CONFLICT OCCURS, RECESSED LIGHT LOCATION GOVERNS.
7. PROVIDE DOUBLE JOISTS AT EACH SIDE OF JOISTS THAT ARE CUT. DO NOT CUT MORE THAN TWO ADJACENT JOISTS.
8. REFER TO TABLES S102.1 AND S102.2 FOR HEADER SCHEDULE. ALL HEADERS WILL COMPLY WITH SAID SCHEDULE UNLESS NOTED OTHERWISE.
9. PROVIDE 5/8" DECKING FOR A/C UNITS AND WATER HEATER. REFER TO MECHANICAL PLAN M101 FOR REFERENCE.
10. SEE REFLECTED CEILING PLAN A102 FOR ACCESS PANEL SIZE & LOCATION. COORDINATE EXACT LOCATION W/EQUIPMENT LAYOUT. COORDINATE ROUGH OPENING DIMENSIONS WITH ACCESS PANEL MANUFACTURER.
11. REFER TO DOOR AND WINDOW SCHEDULES FOR OPENING DIMENSIONS.
12. PROVIDE LOOKOUTS OF EQUAL SIZE OF ADJACENT CEILING JOISTS WHERE CEILING JOISTS ARE NOT PARALLEL TO ROOF RAFTERS.
13. ALL CEILING JOISTS SHALL BE CONNECTED TO ROOF RAFTERS AT ALL ROOF/CEILING FRAMING JUNCTIONS.
14. DO NOT PLACE PLYWOOD DECKING ABOVE IT CLOSET 105 OR WALLS ENCLOSING IT TO ACCOMMODATE CONDUITS AND SNEEPS. COORDINATE WITH RELEVANT TRADES CLEARANCE REQUIREMENTS.
15. ADJUST FRAMED OPENING AS NECESSARY TO ACCOMMODATE CLEARANCE NEEDED FOR TELESCOPING ATTIC STAIR.

LEGEND

- CEILING JOIST SPAN DIRECTION AND JOIST SIZE
- EXTENTS OF 3/4" PLYWOOD DECK
- EXTENTS OF 5/8" PLYWOOD DECK
- FRAMED OPENING

TABLE S102.1 - HEADER SPANS - INTERIOR LOADBEARING WALLS
WFCM 2001 Table 3.24A1 & 3.24B1

HEADER SUPPORTING	SIZE	BUILDING WIDTH (FT)		
		12	24	36
		SPAN (FT - IN)		
ONE FLOOR (CENTER BEARING)	(2) 2x4	4'-0"	2'-10"	2'-4"
	(2) 2x6	5'-11"	4'-3"	3'-5"
	(2) 2x8	7'-1"	5'-2"	4'-4"
	(2) 2x10	7'-11"	6'-0"	5'-0"
	(2) 2x12	8'-6"	6'-7"	5'-7"
	(3) 2x8	8'-5"	6'-4"	5'-3"
	(3) 2x10	9'-3"	7'-1"	6'-0"
	(3) 2x12	9'-11"	7'-8"	6'-7"
	(4) 2x8	9'-5"	7'-2"	6'-0"
	(4) 2x10	10'-3"	7'-11"	6'-9"
	(4) 2x12	11'-0"	8'-7"	7'-4"
TWO FLOORS ONLY (CENTER BEARING)	(2) 2x4	2'-7"	1'-11"	1'-7"
	(2) 2x6	3'-10"	2'-10"	2'-5"
	(2) 2x8	4'-9"	3'-7"	3'-0"
	(2) 2x10	5'-6"	4'-2"	3'-6"
	(2) 2x12	6'-1"	4'-9"	4'-1"
	(3) 2x8	5'-10"	4'-5"	3'-9"
	(3) 2x10	6'-7"	5'-1"	4'-4"
	(3) 2x12	7'-2"	5'-8"	4'-11"
	(4) 2x8	6'-7"	5'-1"	4'-3"
	(4) 2x10	7'-5"	5'-9"	4'-11"
	(4) 2x12	8'-0"	6'-4"	5'-6"

MAXIMUM SPAN 16'-0"
NOTE: BUILDING WIDTH IS MEASURE PERPENDICULAR TO THE RIDGE. FOR WIDTHS BETWEEN THOSE SHOWN, SPANS ARE PERMITTED TO BE INTERPOLATED.

TABLE S102.2 - HEADER SPANS - EXPOSURE "C" FOR EXTERIOR LOADBEARING WALLS
WFCM 2001 Table 3.23a

HEADER SIZE	SPAN	NUMBER FULL HEIGHT STUDS REQ AT EA END
(2) 2x4	4'-0"	TWO
(2) 2x6	4'-10"	TWO
(2) 2x8	5'-4"	TWO
(2) 2x10	5'-8"	TWO
(2) 2x12	6'-1"	TWO
(3) 2x8	6'-6"	THREE
(3) 2x10	7'-0"	THREE
(3) 2x12	7'-5"	THREE
(4) 2x8	7'-6"	FOUR
(4) 2x12	8'-7"	FOUR

140 MPH WIND - EXPOSURE 'C' (TYPICAL) EACH W/1/2" PLYWOOD SPACER BETWEEN

NOTE:
1. ALL HEADERS SHALL HAVE SOLID BLOCKING.

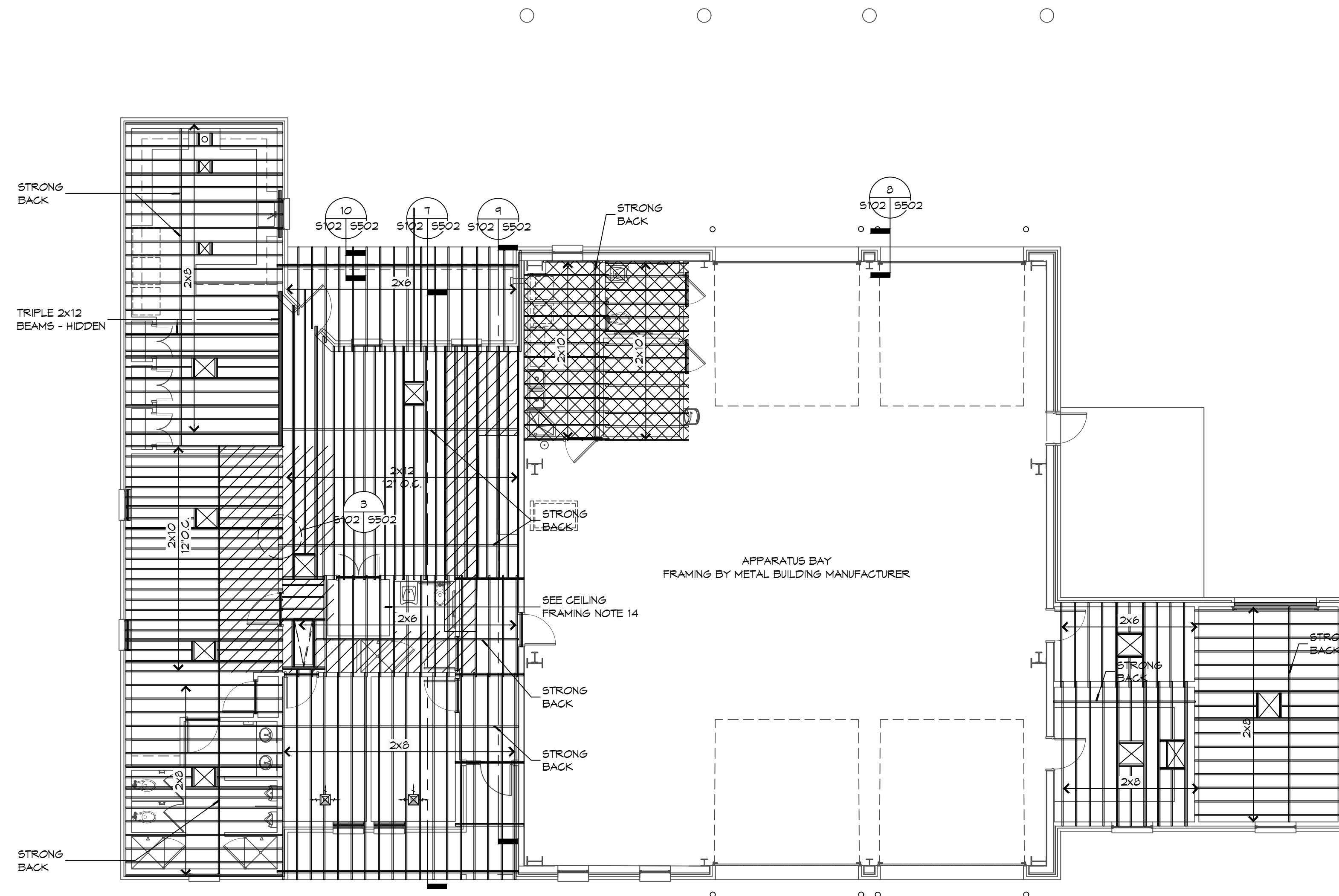

1 CEILING FRAMING PLAN
SCALE: 1/8" = 1'-0"

DAMMON
ENGINEERING, INC.
LOUISIANA & MISSISSIPPI

Chief Engineer: Brian Mistich, PE
554 Old Spanish Trail
Slidell, LA 70458
www.dammonengineering.com
info@dammonengineering.com
PH: 985.649.5832

REVISIONS	DATE	DESCRIPTION



NEW FIRE STATION #10
ST. TAMMANY FIRE PROTECTION DISTRICT NO. 1

248 LAKESHORE VISTA BLVD
SLIDELL, LA 70461
JOB No: 2519 DATE: 12-05-2025
DRAWN BY: CKD CHECKED BY: BAK

SHEET TITLE:
CEILING FRAMING PLAN AND DETAILS

DRAWING NUMBER:

S102

FILE NAME: S:\Projects\2025\2501\2501-01\2501-01.dwg PLOT DATE: 12/05/2025 PLOT TIME: 10:00:00 AM

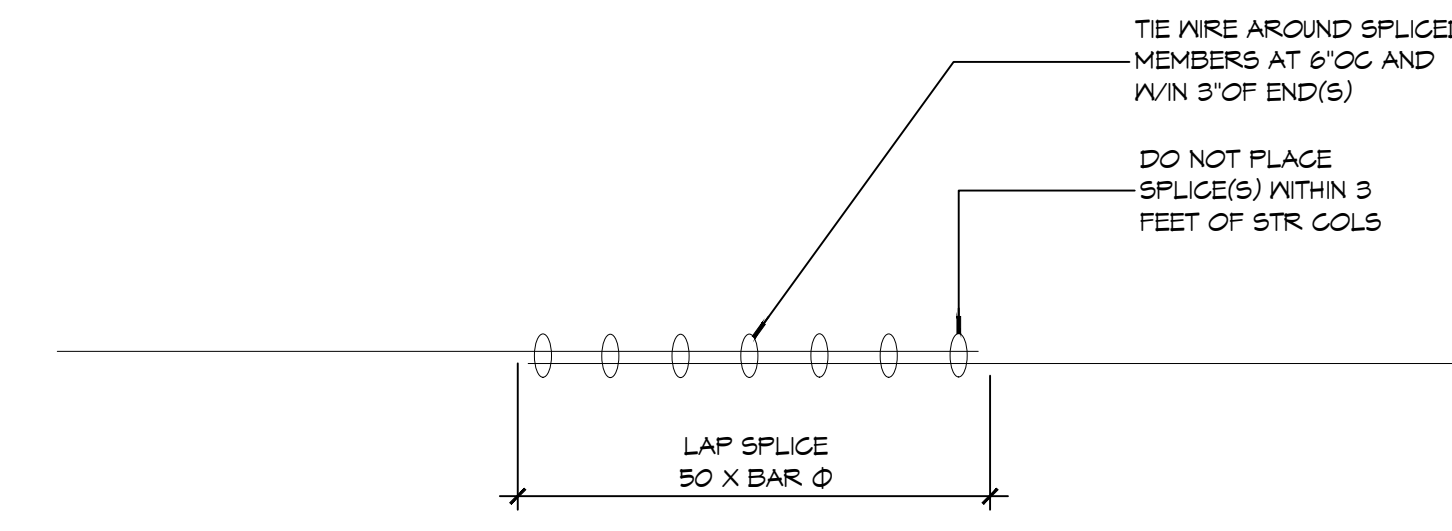

14 FOUNDATION DETAIL

SCALE: NTS

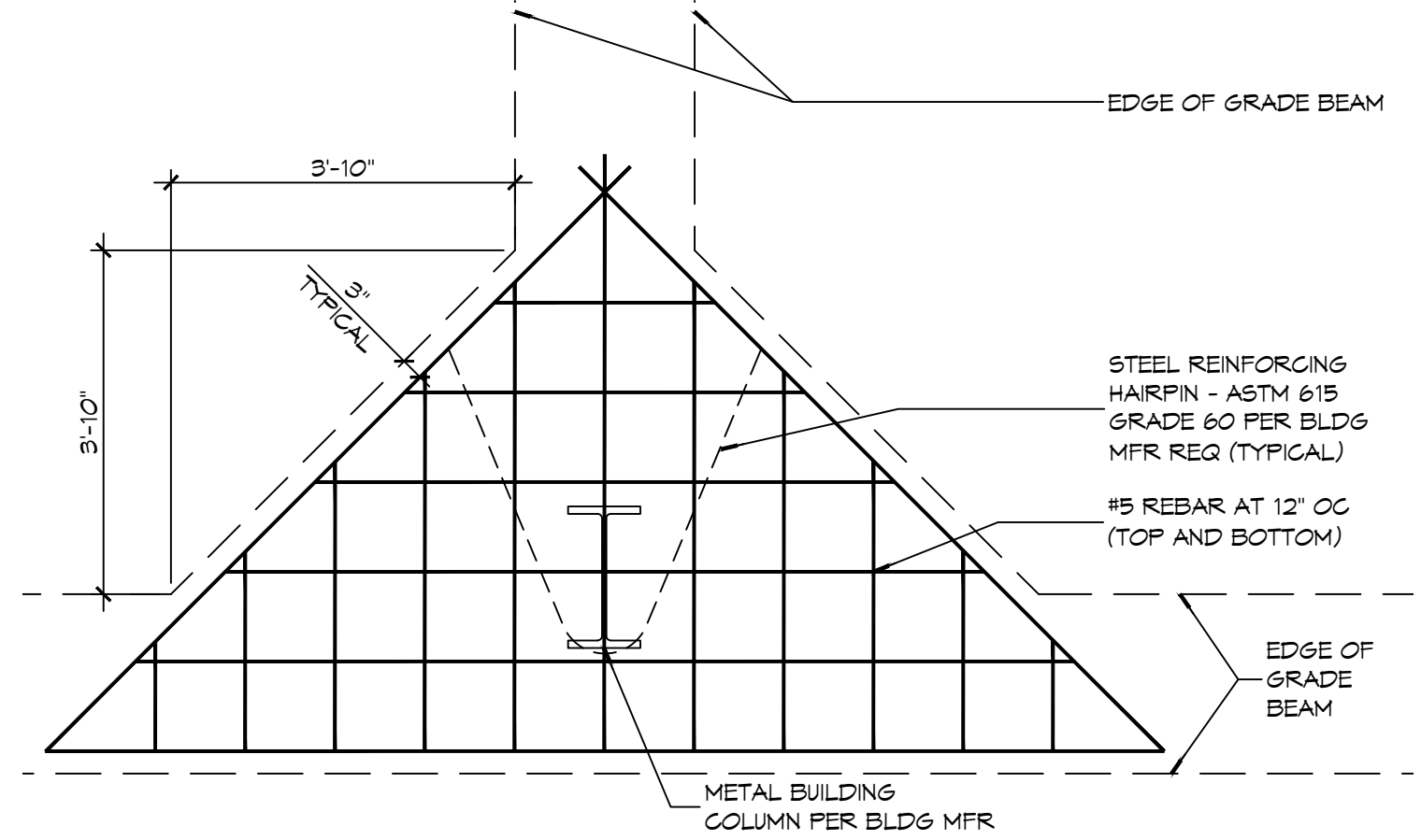

13 FOUNDATION DETAIL

SCALE: 1/2" = 1'-0"

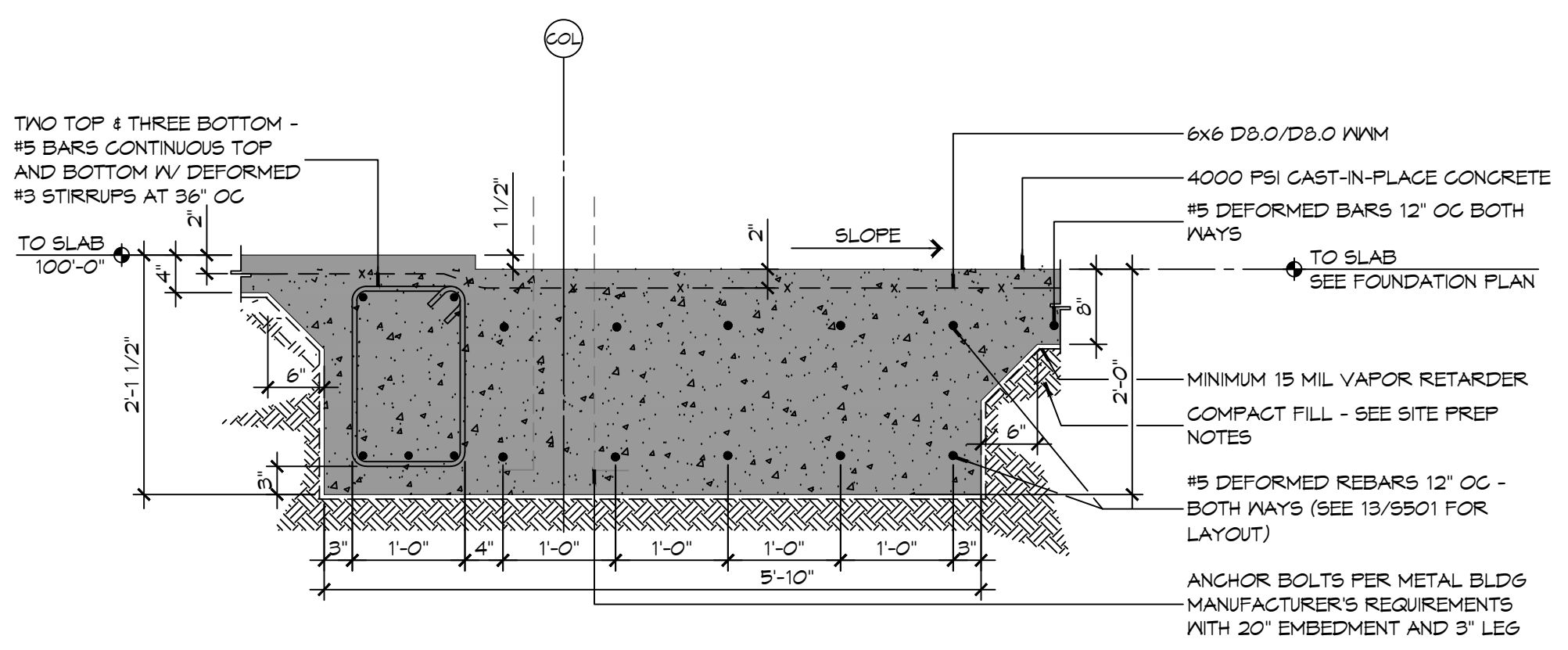

12 FOUNDATION DETAIL

SCALE: 3/4" = 1'-0"

GENERAL FOUNDATION NOTES

1. CONCRETE REINFORCING STEEL SHALL CONFORM TO THE REQUIREMENTS OF ASTM A605, GRADE 60. REINFORCING TO BE WELDED SHALL CONFORM TO THE REQUIREMENTS OF ASTM A706, GRADE 60, UNLESS NOTED OTHERWISE.
2. FABRICATION OF REINFORCING STEEL SHALL BE IN ACCORDANCE WITH THE DETAILS OF AC308-91, "DETAILING OF CONCRETE REINFORCEMENT".
3. CORNER BARS SHALL BE PROVIDED AT ALL CORNERS AND INTERSECTIONS OF CONCRETE BEAMS, GRADE BEAMS, WALLS, AND STEM WALLS.
4. UNLESS NOTED OTHERWISE, CONCRETE COVER SHALL CONFORM TO THE MINIMUMS REQUIRED BY AC308-08.
5. THE CONTRACTOR SHALL BE RESPONSIBLE FOR THE STABILITY OF THE STRUCTURE DURING CONSTRUCTION.
6. WORK NOT INDICATED AS PART OF THE DRAWINGS BUT REASONABLY IMPLIED TO BE SIMILAR TO THAT A CORRESPONDING PLACES SHALL BE REPEATED.
7. ALL EXCAVATIONS FOR FOOTINGS OR PILE CAPS SHALL BE MADE TO GRADES SHOWN. CONTRACTOR SHALL TAKE MEASURES TO PREVENT CAVE-IN OF THE FOOTING EXCAVATION. THESE MEASURES MAY INCLUDE CUTTING BACK THE SIDE SLOPES AND/OR THE USE OF SIDE FORMS.

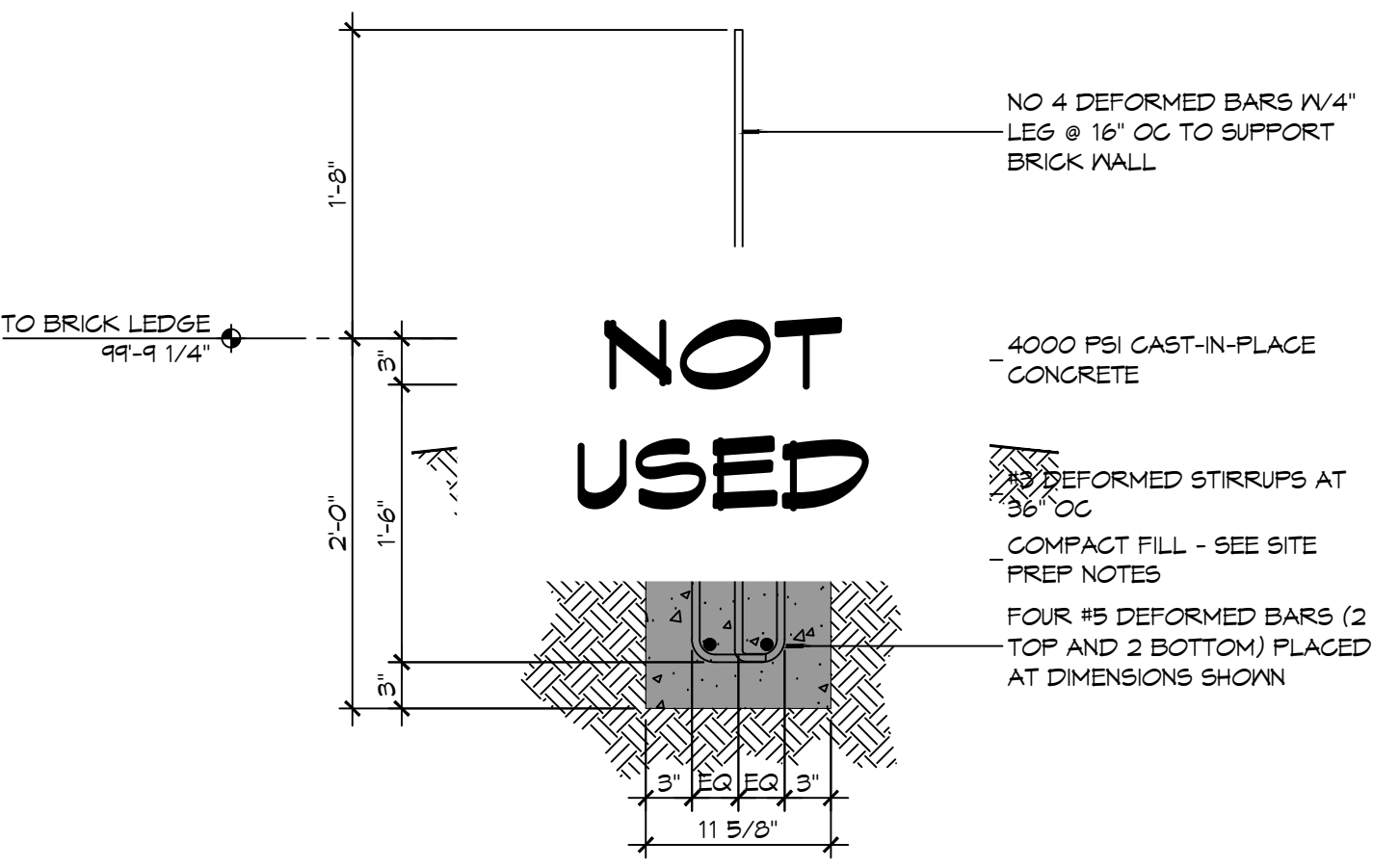

11 FOUNDATION DETAIL

SCALE: 1" = 1'-0"

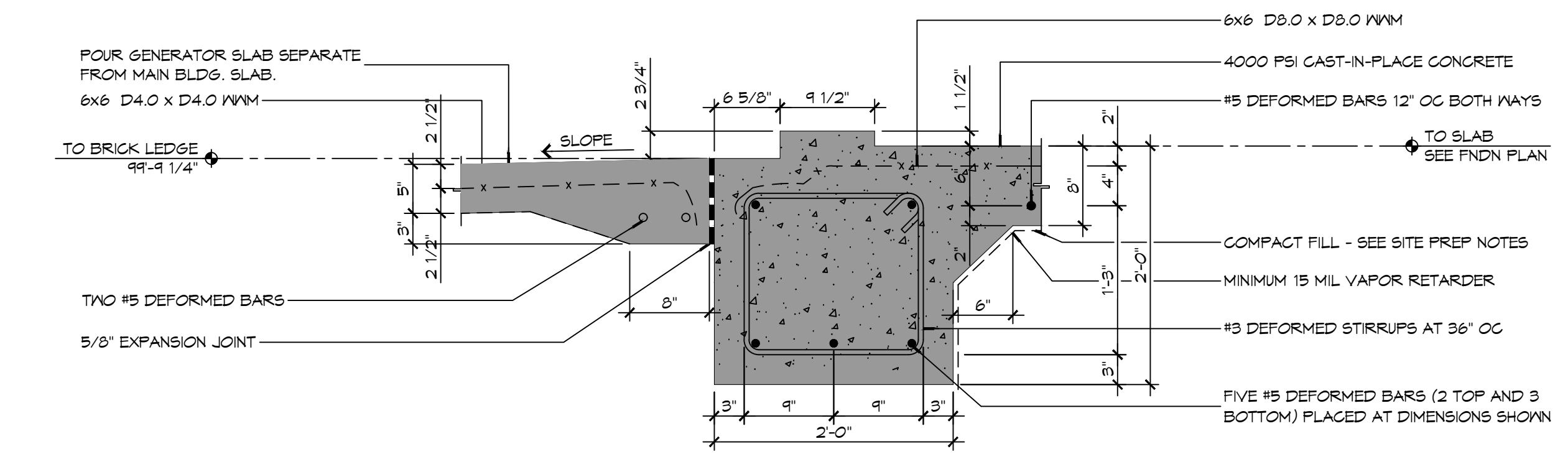

10 FOUNDATION DETAIL

SCALE: 1" = 1'-0"

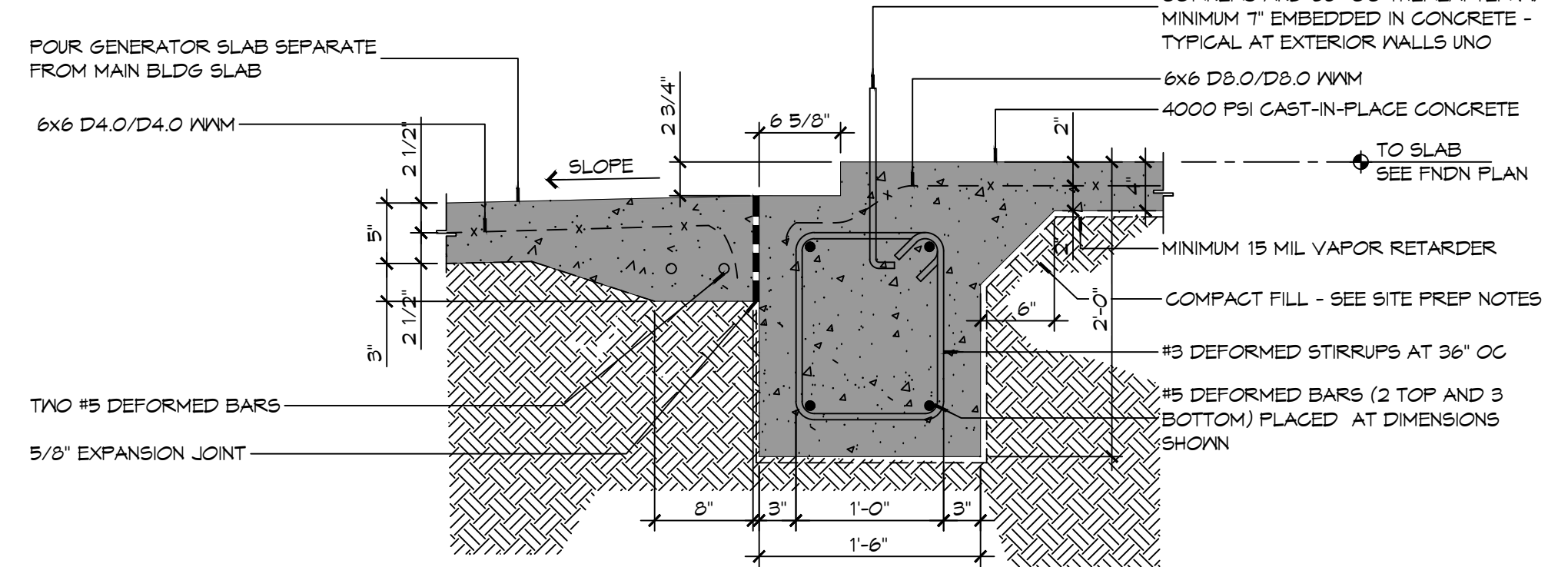

9 FOUNDATION DETAIL

SCALE: 1" = 1'-0"

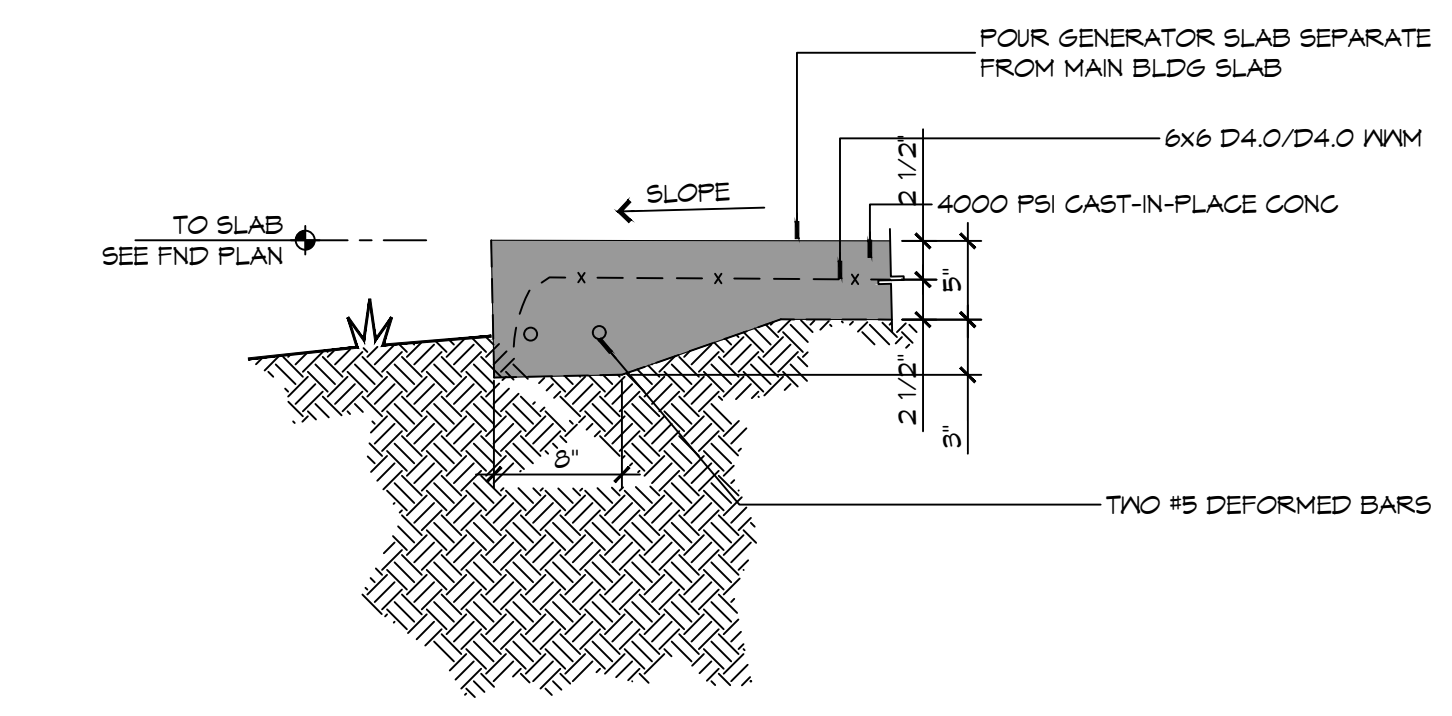

8 FOUNDATION DETAIL

SCALE: 1" = 1'-0"

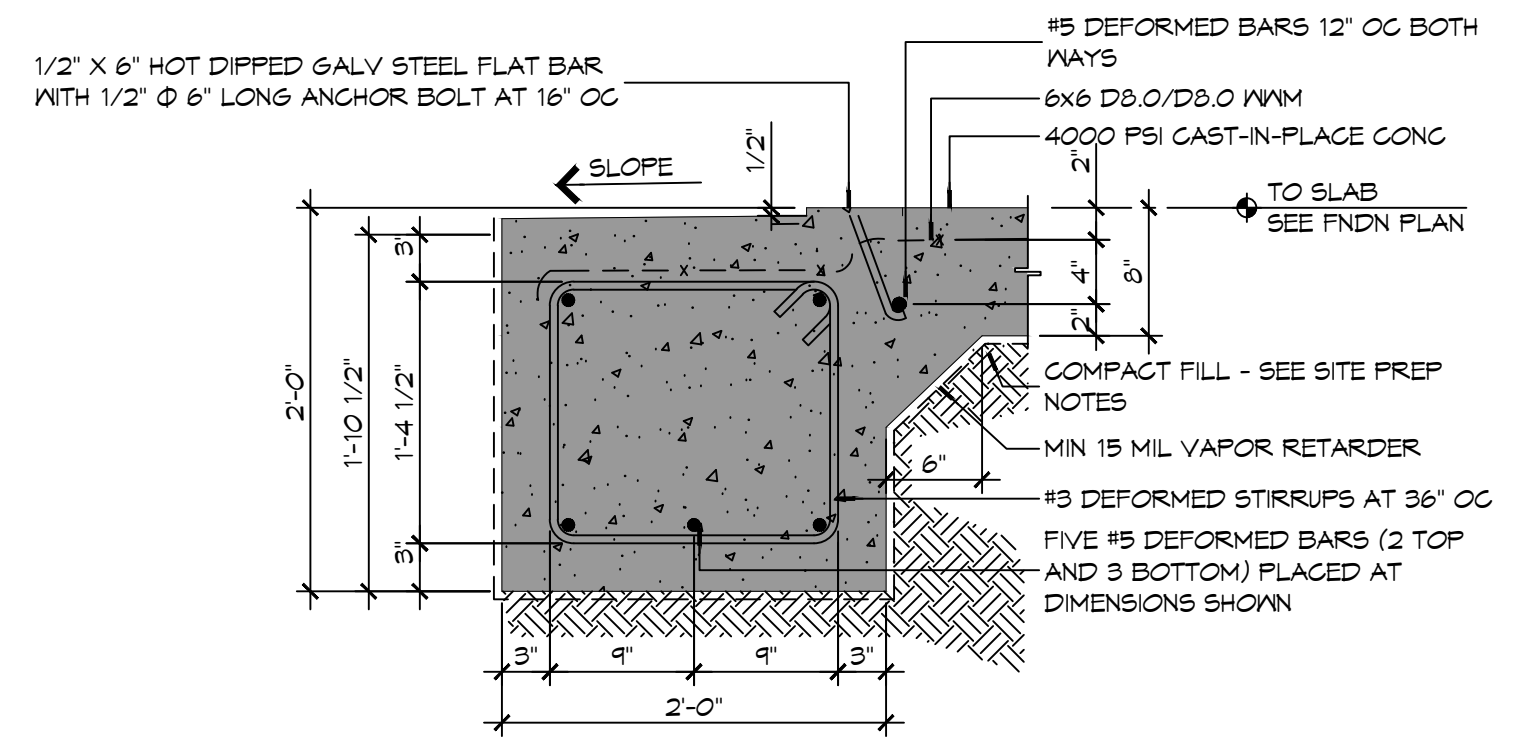

7 FOUNDATION DETAIL

SCALE: 1" = 1'-0"

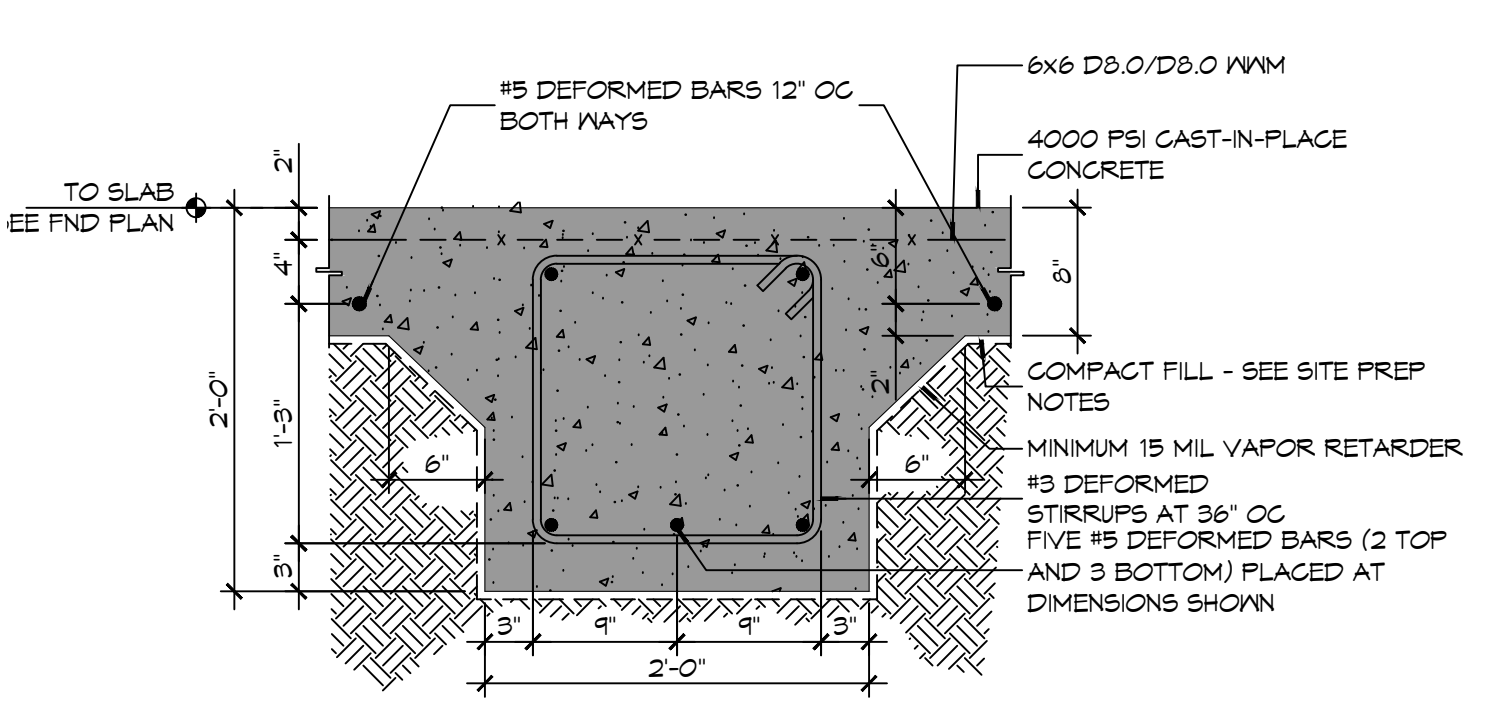

6 FOUNDATION DETAIL

SCALE: 1" = 1'-0"

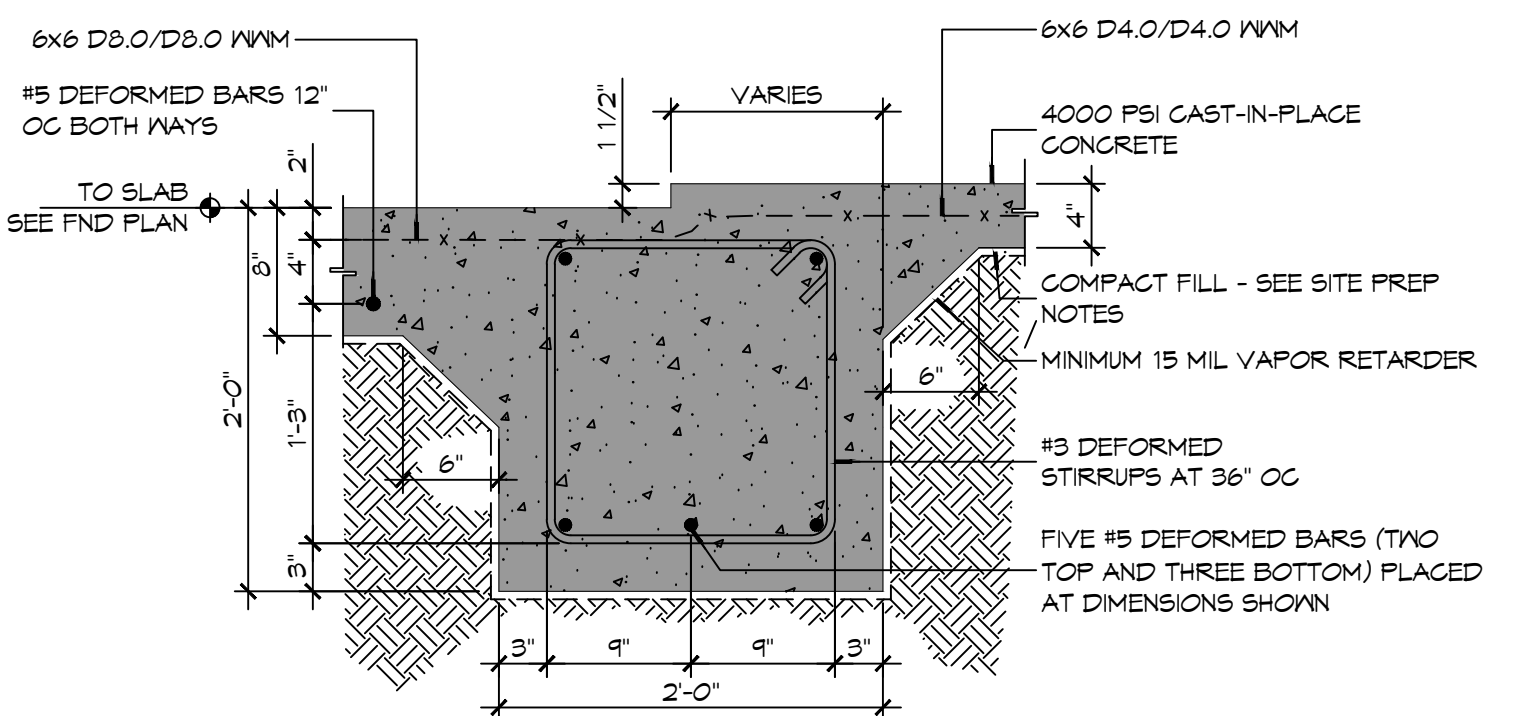

5 FOUNDATION DETAIL

SCALE: 1" = 1'-0"

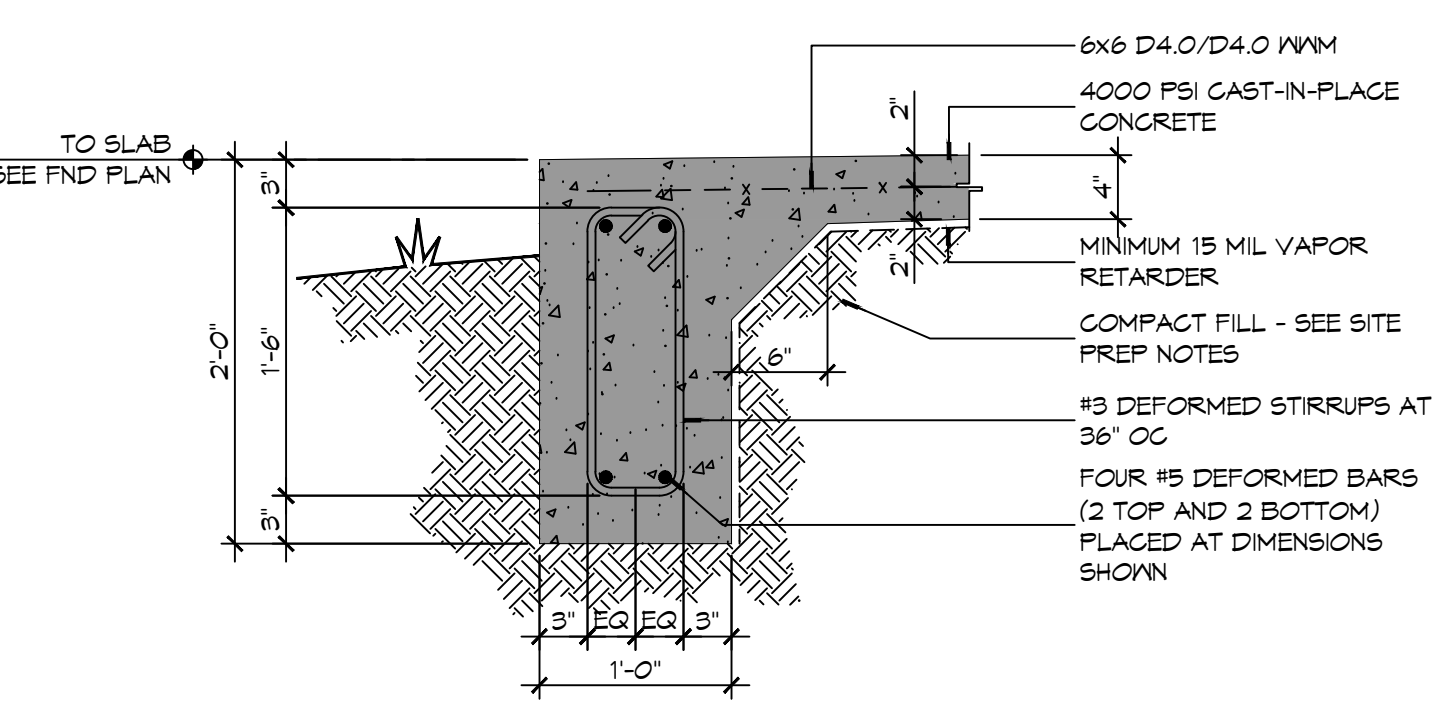

4 FOUNDATION DETAIL

SCALE: 1" = 1'-0"

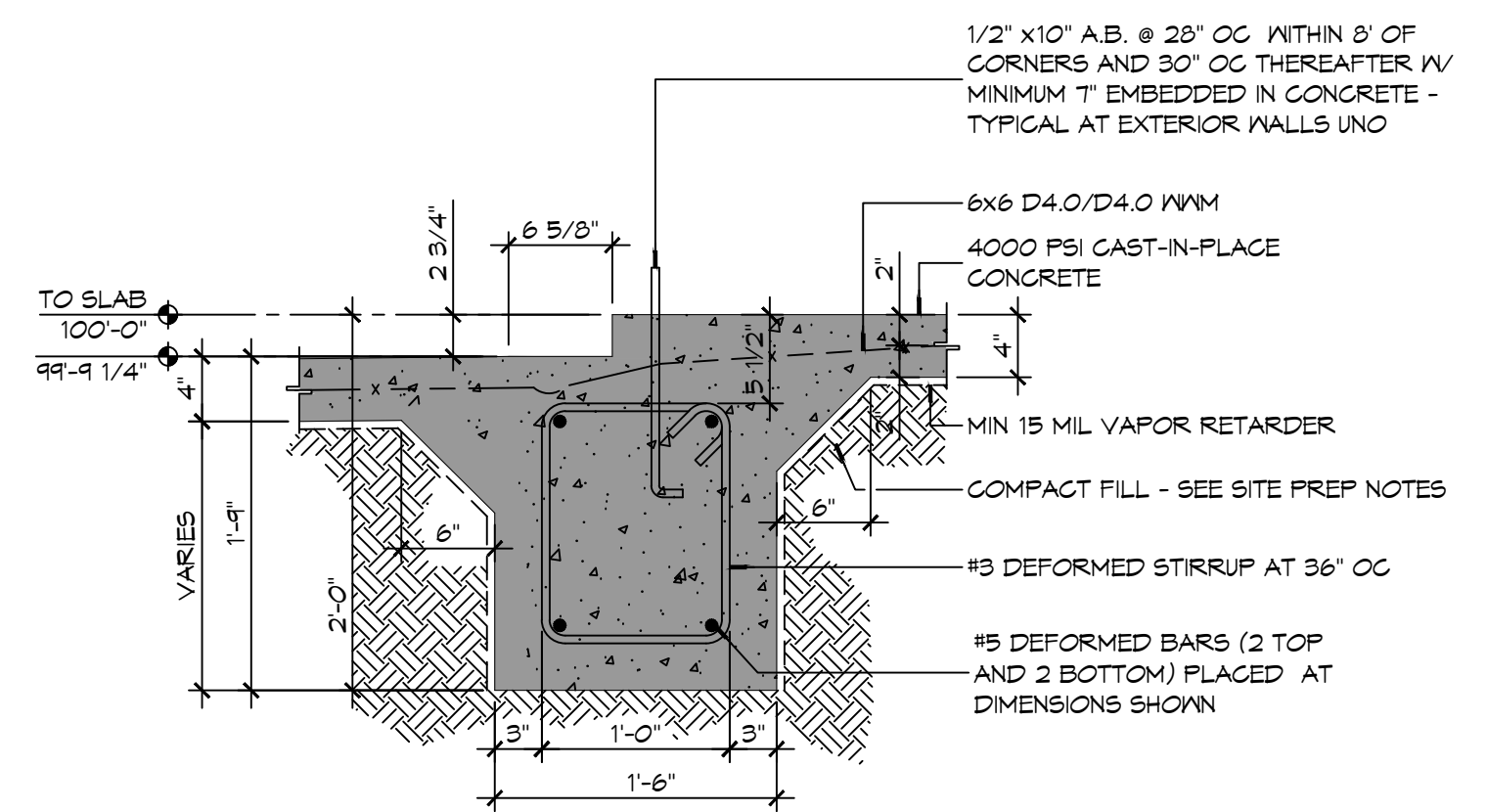

3 FOUNDATION DETAIL

SCALE: 1" = 1'-0"

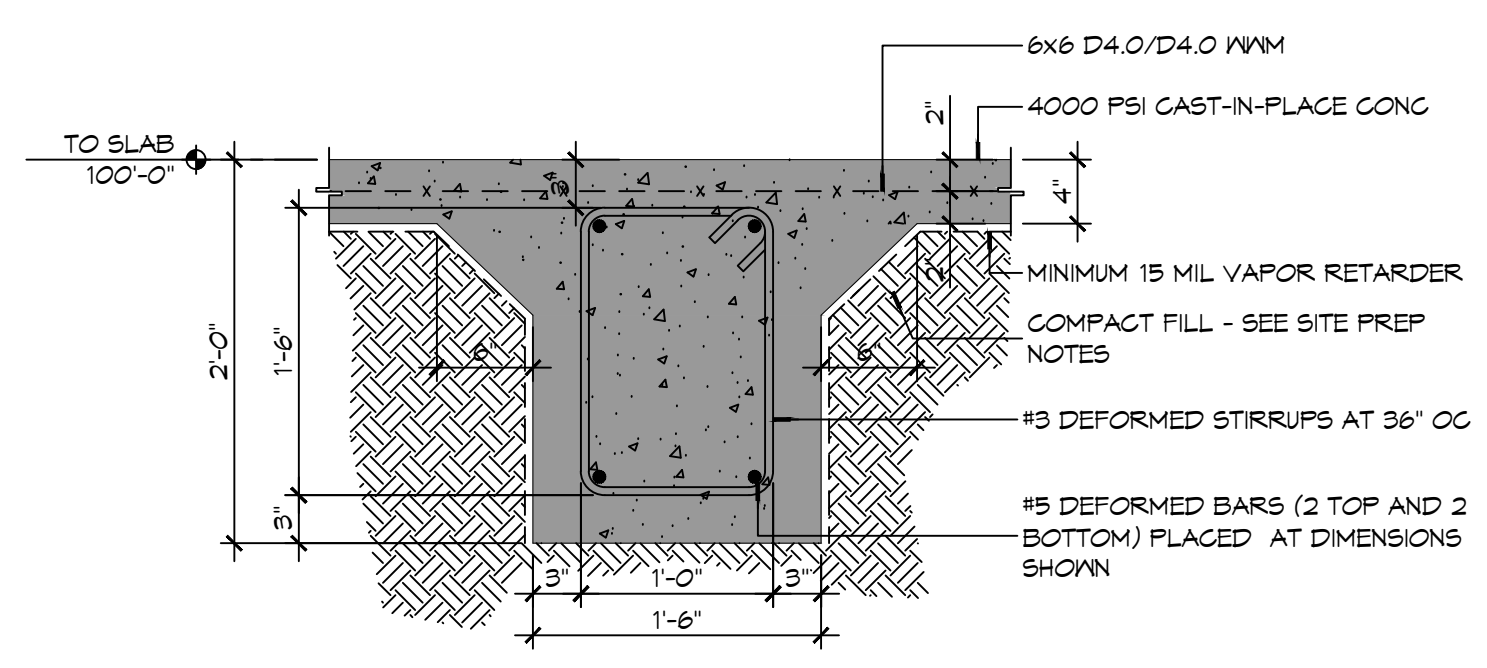

2 FOUNDATION DETAIL

SCALE: 1" = 1'-0"

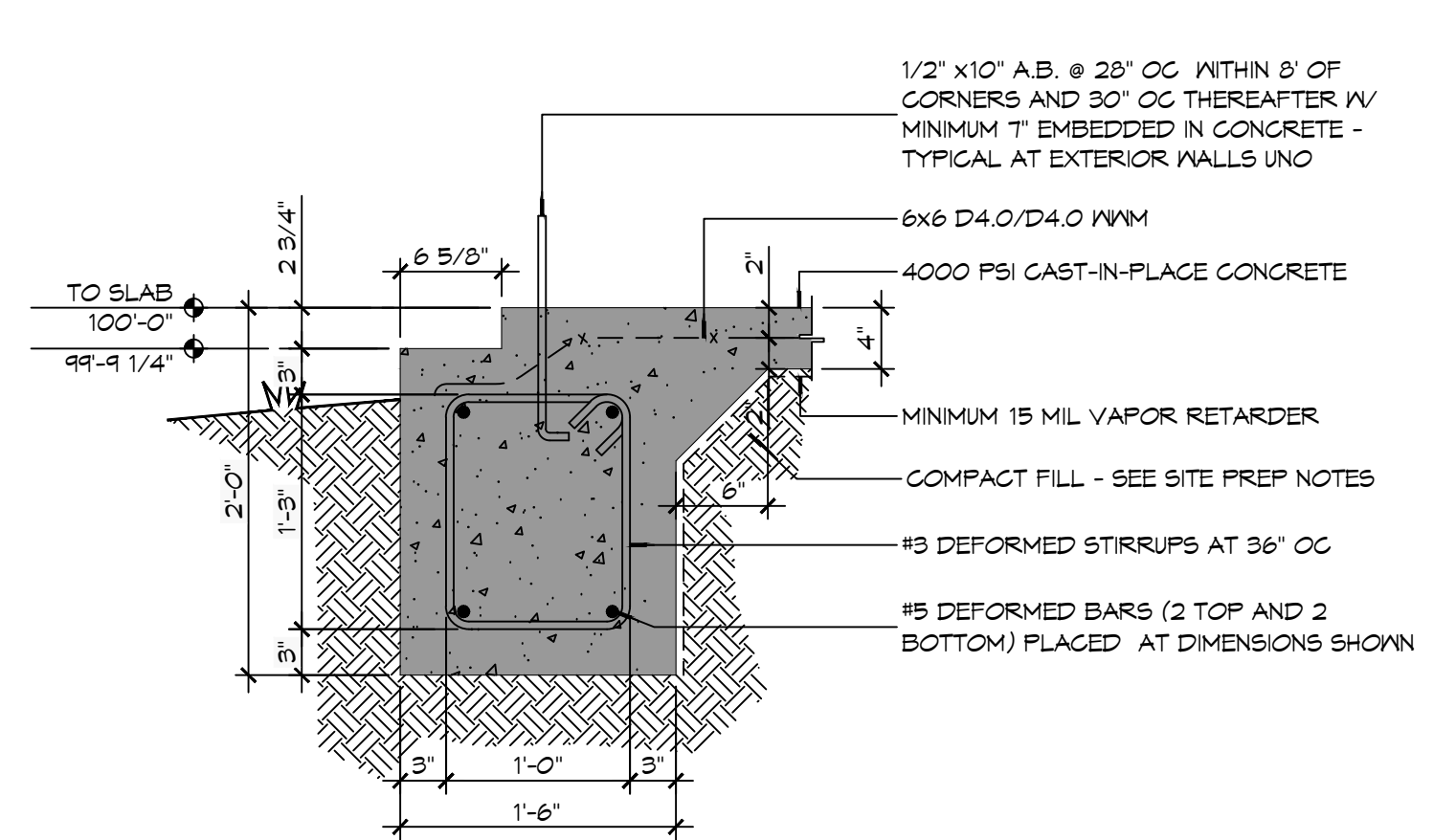

1 FOUNDATION DETAIL

SCALE: 1" = 1'-0"

DAMMON ENGINEERING, INC.
 LOUISIANA & MISSISSIPPI
 Chief Engineer: Brian Mistich, PE
 554 Old Spanish Trail
 Slidell, LA 70688
 www.dammonengineering.com
 info@dammonengineering.com
 PH: 985.649.5832

#	DESCRIPTION	DATE



NEW FIRE STATION #10
ST. TAMMANY FIRE PROTECTION DISTRICT NO. 1
 2148 LAKESHORE VISTA BLVD
 SLIDELL, LA 70661
 JOB No: 2519 DATE: 12-05-2025
 DRAWN BY: CKD CHECKED BY: BAK
 SHEET TITLE: FOUNDATION DETAILS
 DRAWING NUMBER: **S501**
 SHEET No: 15 of 37

TABLE S601.7 - UPLIFT CONNECTIONS - 140 MPH WINDS EXP "C"
WFCM 2021 TABLE 3.2

CONNECTION	FRAMING SPACING (INCHES)	ROOF SPAN (FEET)	UPLIFT	LATERAL	SHEAR	NUMBER OF 8d COMMON NAILS OR 10d BOX NAILS IN EACH END OF 1-1/4"x20 GAGE STRAP
ROOF ASSEMBLY TO WALL ASSEMBLY	16" OC	16	401	292	152R	4
WALL ASSEMBLY TO FOUNDATION	16" OC	16	224	219	436	4

TABLE S601.8 - SILL OR BOTTOM PLATE TO FOUNDATION CONNECTIONS RESISTING UPLIFT LOADS - 140 MPH WIND EXP "C"
WFCM 2021 TABLE 3.2C

BOTTOM PLATE TO FOUNDATION ANCHOR BOLT CONNECTION RESISTING	FOUNDATION SUPPORTING	MAXIMUM ANCHOR BOLT SPACING (INCHES)	
		8' END ZONES	INTERIOR ZONES
UPLIFT LOADS	1 - 3 STORIES	25 INCHES ON CENTER	30 INCHES ON CENTER

NOTE: A MINIMUM OF ONE ANCHOR BOLT SHALL BE PROVIDED WITHIN 6 TO 12 INCHES OF EACH END OF EACH PLATE

TABLE S601.9 - SILL OR BOTTOM PLATE TO FOUNDATION CONNECTIONS RESISTING SHEAR LOADS - 140 MPH WIND EXP "C"
WFCM 2021 TABLE 3.2B

BOTTOM PLATE TO FOUNDATION ANCHOR BOLT CONNECTION RESISTING	FOUNDATION SUPPORTING	MAXIMUM ANCHOR BOLT SPACING (INCHES)	
		1/2" Ø ANCHOR BOLTS	5/8" Ø ANCHOR BOLTS
UPLIFT LOADS	1 STORY	30 INCHES ON CENTER	48 INCHES ON CENTER

TABLE S601.10 - FULL HEIGHT STUD REQUIREMENT FOR HEADERS OR WINDOW SILL PLATES IN EXTERIOR WALLS EXPOSURE "C"
WFCM 2021 TABLE 3.23C

HEADER SPAN (FEET)	WALL SPACING (INCHES)		
	12" OC	16" OC	24" OC
2	1	1	1
4	2	2	1
6	3	3	2
8	4	3	2

TABLE S601.5 - JACK STUD REQ - INT LOADBEARING WALLS
WFCM 2021 TABLE 3.22F

HEADER SUPPORTING	HEADER SPAN (FT)	ROOF SPAN (FEET)											
		12 FEET				24 FEET				36 FEET			
		3"	4.5"	5"	6.5"	3"	4.5"	5"	6.5"	3"	4.5"	5"	6"
ONE FLOOR ONLY (CENTER BEARING)	2	1	1	1	1	1	1	1	1	1	1	1	1
	4	1	1	1	1	1	1	1	1	1	1	1	1
	6	1	1	1	1	1	1	1	1	2	1	1	1
	8	1	1	1	1	2	1	1	1	2	2	2	1
	10	1	1	1	1	2	2	1	1	3	2	2	2
	12	1	1	1	1	2	2	2	1	3	2	2	2
TWO FLOORS (CENTER BEARING)	2	2	1	1	1	3	2	2	2	4	3	3	2
	4	1	1	1	1	2	1	1	1	3	2	2	2
	6	2	1	1	1	3	2	2	2	4	3	2	2
	8	2	2	1	1	3	2	2	2	5	3	3	3
	10	2	2	2	1	4	3	3	2	6	4	4	3
	12	3	2	2	2	5	3	3	3	7	5	4	4
ROOF AND CEILING	2	3	2	2	2	6	4	4	3	8	5	5	4
	4	4	3	2	2	6	4	4	3	9	6	6	5
	6	2	1	1	1	3	2	2	2	4	3	2	2
	8	2	2	1	1	3	2	2	2	5	3	3	3
	10	2	2	2	1	4	3	3	2	6	4	4	3
	12	3	2	2	2	5	3	3	3	7	5	4	4

TABLE S601.6 - JACK STUD REQ - EXTERIOR LOADBEARING WALLS
WFCM 2021 TABLE 3.22F

	HEADER WIDTH - 3" (2-2X), 4.5" (3-2X), 5", 6.5" (4-2X) EACH 1/2" PLYWOOD SPACER BETWEEN	ROOF LIVE LOAD 20 PSF				ROOF LIVE LOAD 30 PSF			
		3"	4.5"	5"	6.5"	3"	4.5"	5"	6.5"
		NUMBER OF JACK STUDS REQUIRED							
ROOF AND CEILING	2	1	1	1	1	1	1	1	1
	4	1	1	1	1	1	1	1	1
	6	2	1	1	1	2	1	1	1
	8	2	2	2	1	2	2	2	1
	10	3	2	2	2	3	2	2	2
	12	3	2	2	2	3	2	2	2
ROOF, CEILING, AND ONE CENTER BEARING FLOOR	2	1	1	1	1	1	1	1	1
	4	2	1	1	1	2	1	1	1
	6	2	2	2	1	3	2	2	2
	8	3	2	2	2	3	2	2	2
	10	4	3	2	2	4	3	3	2
	12	4	3	3	2	5	3	3	3
ROOF AND CEILING	2	5	4	3	3	5	4	3	3
	4	6	4	4	3	6	4	4	3

TABLE S601.2 - WALL SHEATHING OR CLADDING REQUIREMENT - WIND LOAD EXP "C"

SHEATHING LOCATION	STUD SPACING	MAX NAIL SPACING FOR 8d COMMON NAILS OR 10d BOX NAILS (INCHES OC)	
		E	F
INTERIOR ZONE	12" OC	6	12
	16" OC	6	12
	24" OC	6	6
PERIMETER EDGE ZONE	12" OC	6	12
	16" OC	6	6
	24" OC	6	6

140 MPH WIND - EXPOSURE "C" TYPICAL
E = NAIL SPACING AT PANEL EDGES, INCHES.
F = NAIL SPACING AT INTERMEDIATE SUPPORTS IN THE PANEL FIELD, INCHES.

TABLE S601.3 - NAILING SCHEDULE
WFCM 2001 TABLE 3.1

DESCRIPTION	NUMBER OF COMMON NAILS	NUMBER OF BOX NAILS	SPACING
HEADER TO HEADER (FACE NAILED)	16d	16d	16" OC EDGES

TABLE S601.4 - BUILDING ENVELOPE REQUIREMENTS

OPAQUE ELEMENTS	ASSEMBLY MAXIMUM	INSULATION MIN. R-VALUE
ROOFS	INSULATION ENTIRELY ABOVE DECK	U-0.040 R-20.0 c.i.
	METAL BUILDING	U-0.065 R-19
	ATTIC AND OTHER	U-0.027 R-30
WALLS, ABOVE GRADE	MASS	U-0.151 R-5.1 c.i.
	METAL BUILDING	U-0.113 R-13.0
	STEEL-FRAMED	U-0.124 R-13.0
	WOOD-FRAMED AND OTHER	U-0.089 R-13.0
FLOORS	MASS	U-0.107 R-6.3 c.i.
	STEEL JOIST	U-0.052 R-19.0
SLAB-ON-GRADE	WOOD FRAMED AND OTHER	U-0.051 R-19.0
	UN-HEATED	F-0.730 NR
OPAQUE DOORS	SWINGING	U-0.700 NR
	NON-SWINGING	U-1.450 NR

ROOF UNDERLAYMENT NOTES

- FOR ROOF SLOPES FROM TWO UNITS VERTICAL IN 12 UNITS HORIZONTAL (17-PERCENT SLOPE), UP TO FOUR UNITS VERTICAL IN 12 UNITS HORIZONTAL (33-PERCENT SLOPE), UNDERLAYMENT SHALL BE TWO LAYERS APPLIED IN THE FOLLOWING MANNER:
 - APPLY A 14 INCH STRIP OF UNDERLAYMENT FELT PARALLEL WITH AND STARTING AT THE EAVES, FASTENED SUFFICIENTLY TO HOLD IN PLACE. STARTING AT THE EAVE, APPLY 36 INCH WIDE SHEETS OF UNDERLAYMENT, OVERLAPPING SUCCESSIVE SHEETS 14 INCHES, AND FASTENED SUFFICIENTLY TO HOLD IN PLACE.
- FOR ROOF SLOPES OF FOUR UNITS VERTICAL IN 12 UNITS HORIZONTAL (33-PERCENT SLOPE) OR GREATER, UNDERLAYMENT SHALL BE ONE LAYER APPLIED IN THE FOLLOWING MANNER:
 - UNDERLAYMENT SHALL BE APPLIED SHINGLE FASHION, PARALLEL TO AND STARTING FROM THE EAVE AND LAPPED 2 INCHES, FASTENED SUFFICIENTLY TO HOLD IN PLACE. END LAPS SHALL BE OFFSET BY 6 FEET.

SHINGLE APPLICATION & FASTENING NOTES

- ASPHALT STRIP SHINGLES SHALL HAVE A MINIMUM OF SIX FASTENERS PER SHINGLE WHERE THE ROOF IS IN ONE OF THE FOLLOWING CATEGORIES:
 - THE BASIC WIND SPEED IS 110 MPH OR GREATER AND THE EAVE IS 20 FEET OR HIGHER ABOVE GRADE.
 - THE BASIC WIND SPEED IS 120 MPH OR GREATER.
 - SPECIAL WIND ZONES.

DESIGN CRITERIA

THE CONSTRUCTION FOR SAID RESIDENCE, WHERE BASIC WIND SPEED IS 140 MILES PER HOUR, WIND EXPOSURE ZONE C, IS DESIGNED IN ACCORDANCE WITH AMERICAN FOREST AND PAPER ASSOCIATION (AF&PA) WOOD FRAME CONSTRUCTION MANUAL FOR ONE AND TWO FAMILY DWELLINGS (WFCM) 2001 EDITION AS WELL AS THE INTERNATIONAL RESIDENTIAL CODE (IRC) 2021 EDITION

TABLE S601.10 - FULL HEIGHT STUD REQUIREMENT FOR HEADERS OR WINDOW SILL PLATES IN EXTERIOR WALLS EXPOSURE "C"
WFCM 2021 TABLE 3.23C

NAIL SPACING
X = 4" OC
Y = 4" OC
Z = 12" OC

X = PLATE EDGE NAIL SPACING
Y = LONG EDGE NAIL SPACING
Z = FIELD NAIL SPACING

1 TYPICAL CONNECTION DETAILS
SCALE: NTS

GENERAL UPLIFT CONNECTION NOTES

ROOF ASSEMBLY TO WALL ASSEMBLY:
UPLIFT CONNECTIONS SHALL BE FROM RAFTER OR TRUSS TO WALL STUD. WHEN RAFTERS OR TRUSSES ARE NOT LOCATED DIRECTLY ABOVE STUDS, RAFTERS SHALL BE ATTACHED TO THE WALL PLATE AND THE WALL TOP PLATE SHALL BE ATTACHED TO THE WALL STUD WITH UPLIFT CONNECTIONS. UPLIFT CONNECTIONS SHALL BE IN ACCORDANCE WITH TABLE S601.10.

WALL ASSEMBLY TO WALL ASSEMBLY:
STORY TO STORY UPLIFT CONNECTIONS FROM UPPER STORY WALL STUD TO LOWER STORY WALL STUD. WHEN UPPER STORY WALL STUDS ARE NOT LOCATED DIRECTLY ABOVE LOWER WALL STUDS, THE STUDS SHALL BE ATTACHED TO A COMMON MEMBER IN THE FLOOR ASSEMBLY BY UPLIFT CONNECTIONS. UPLIFT CONNECTIONS SHALL BE IN ACCORDANCE WITH TABLE S601.11.

WALL ASSEMBLY TO FOUNDATION:
FIRST FLOOR WALL STUDS SHALL BE CONNECTED TO THE FOUNDATION, SILL PLATE, OR BOTTOM PLATE. A MINIMUM OF A 1-1/4" x 20 GA. ASTM A653 GRADE 33 STEEL STRAP SHALL BE NAILED TO THE WALL STUDS AND HAVE A MINIMUM EMBEDMENT OF 7 INCHES IN CONCRETE FOUNDATIONS AND SLAB-ON-GRADE. 15 INCHES IN MASONRY BLOCK FOUNDATIONS, OR BE LAPPED UNDER THE BOTTOM PLATE. 3 INCH SQUARE WASHERS SHALL BE USED ON THE ANCHOR BOLTS AND ANCHOR BOLT SPACINGS SHALL NOT EXCEED THE REQUIREMENTS. STEEL STRAPS EMBEDDED IN OR IN CONTACT WITH SLAB-ON-GRADE OR MASONRY BLOCK FOUNDATIONS SHALL BE HOT-DIPPED GALV. AFTER FABRICATION, OR MANUF. FROM G185 OR Z450 GALV. STL. CONNECTIONS SHALL BE IN ACCORDANCE WITH TABLE S601.12.

SECTION **ELEVATION**

(MITERED CORNER)
CORNER STUD CONNECTED TO TRANSFER SHEAR
TWO 16d COMMON NAILS AT 6" OC VERT

SIDEWALL
COMPATIBLE WOOD SCREWS
7/8" Ø ANCHOR ROD/BOLT
SIMPSON STRONG-TIE
SIMPSON ANCHOR
ENDWALL STUD

NOTE: HOLDDOWNS ARE REQUIRED AT THE END OF EACH SEGMENTED SHEARWALL SEGMENT OR AT THE EACH END OF A PERFORATED SHEARWALL. WHEN FULL HEIGHT SHEARWALL SEGMENTS MEET AT A CORNER, A SINGLE HOLDDOWN SHALL BE PERMITTED TO BE USED TO RESIST THE OVERTURNING FORCES IN BOTH DIRECTIONS WHEN THE CORNER FRAMING IN THE ADJOINING WALLS IS FASTENED TOGETHER TO TRANSFER THE UPLIFT LOAD.

(P) CORNER HOLDDOWN

(M) DWG NAME

(L) POST TO BEAM

(K) END WALL CONNECTIONS

(J) SIMPSON M8TAM86

(N) FLITCH BEAM

(I) SIMPSON STRONG-TIE

(H) SHEAR NAIL EXTERIOR SHEATHING NAILING PATTERN

(G) RIDGE BEAM/BOARD

(F) TOP PLATE TO RAFTER

(E) STUD TO TOP PLATE

(D) FLOOR JOIST

(C) DEL FLOOR JOIST

(B) HIP RAFTER

(A) STUD TO SILL PLATE

TABLE S601.1 - ROOF SHEATHING OR CLADDING REQUIREMENT - WIND LOAD EXP "C"

SHEATHING LOCATION	RAFTER / TRUSS SPACING	MAX NAIL SPACING FOR 8d COMMON NAILS OR 10d BOX NAILS (INCHES OC)	
		E	F
INTERIOR ZONE	12" OC	6	12
	16" OC	6	12
	24" OC	6	6
PERIMETER EDGE ZONE	12" OC	6	6
	16" OC	4	4
	24" OC	3	3

140 MPH WIND - EXPOSURE "C" TYPICAL
E = NAIL SPACING AT PANEL EDGES, INCHES.
F = NAIL SPACING AT INTERMEDIATE SUPPORTS IN THE PANEL FIELD, INCHES.

**NEW FIRE STATION #10
ST. TAMMANY FIRE PROTECTION DISTRICT NO. 1**

2148 LAKESHORE VISTA BLVD
SLIDELL, LA 70461

JOB NO: 2519 DATE: 12-05-2025
DRAWN BY: CKD CHECKED BY: BAY

SHEET TITLE: TYPICAL CONNECTION DETAILS, SCHEDULES, AND NOTES

DRAWING NUMBER: **S601**

SHEET No: 17 of 37

DAMMON ENGINEERING, INC.
LOUISIANA & MISSISSIPPI

Chief Engineer: Brian Mistich, PE
554 Old Spanish Trail
Slidell, LA 70458
www.dammonengineering.com
info@dammonengineering.com
PH: 985.649.5632

#	DESCRIPTION	DATE

SEAL:

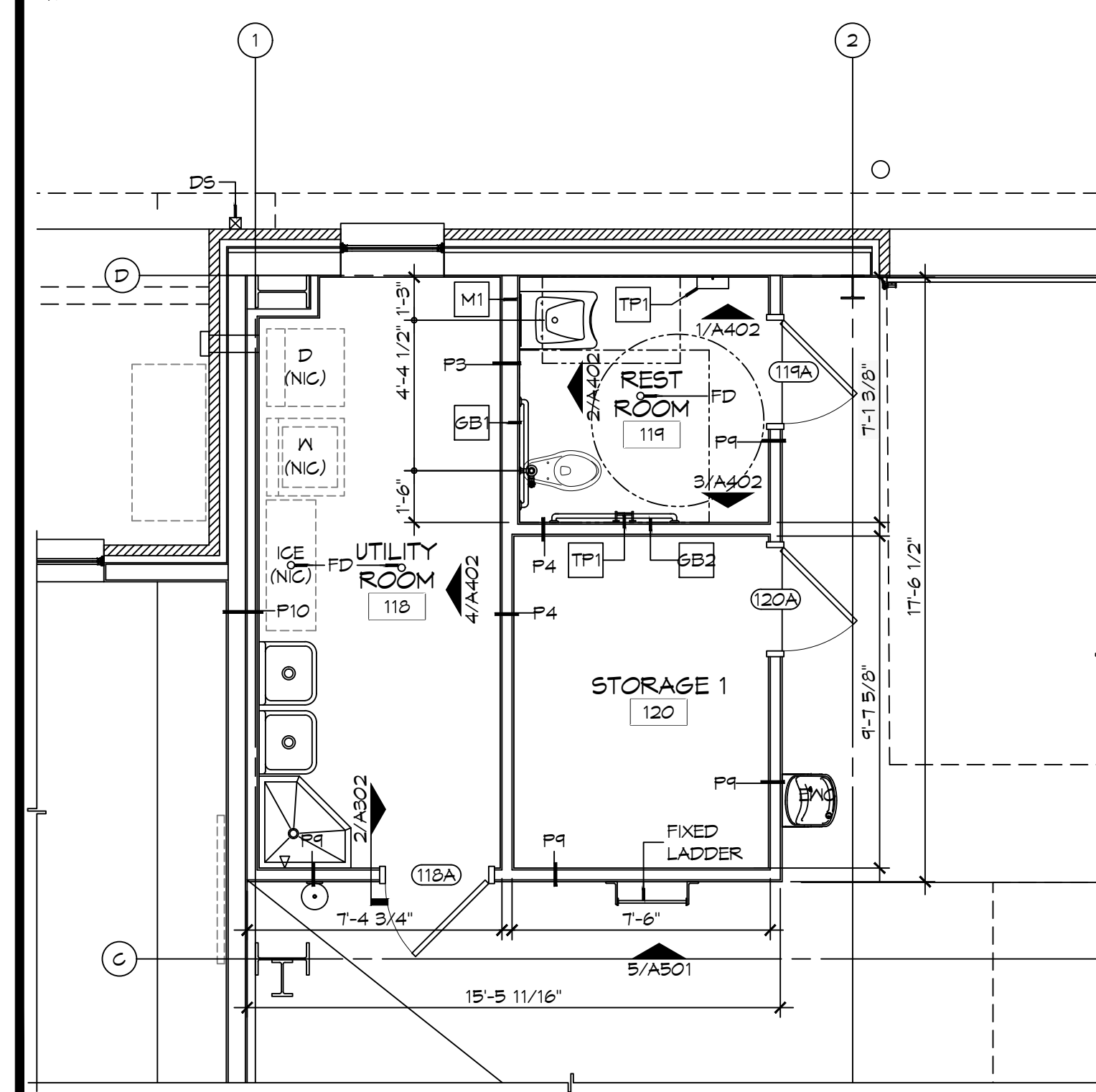
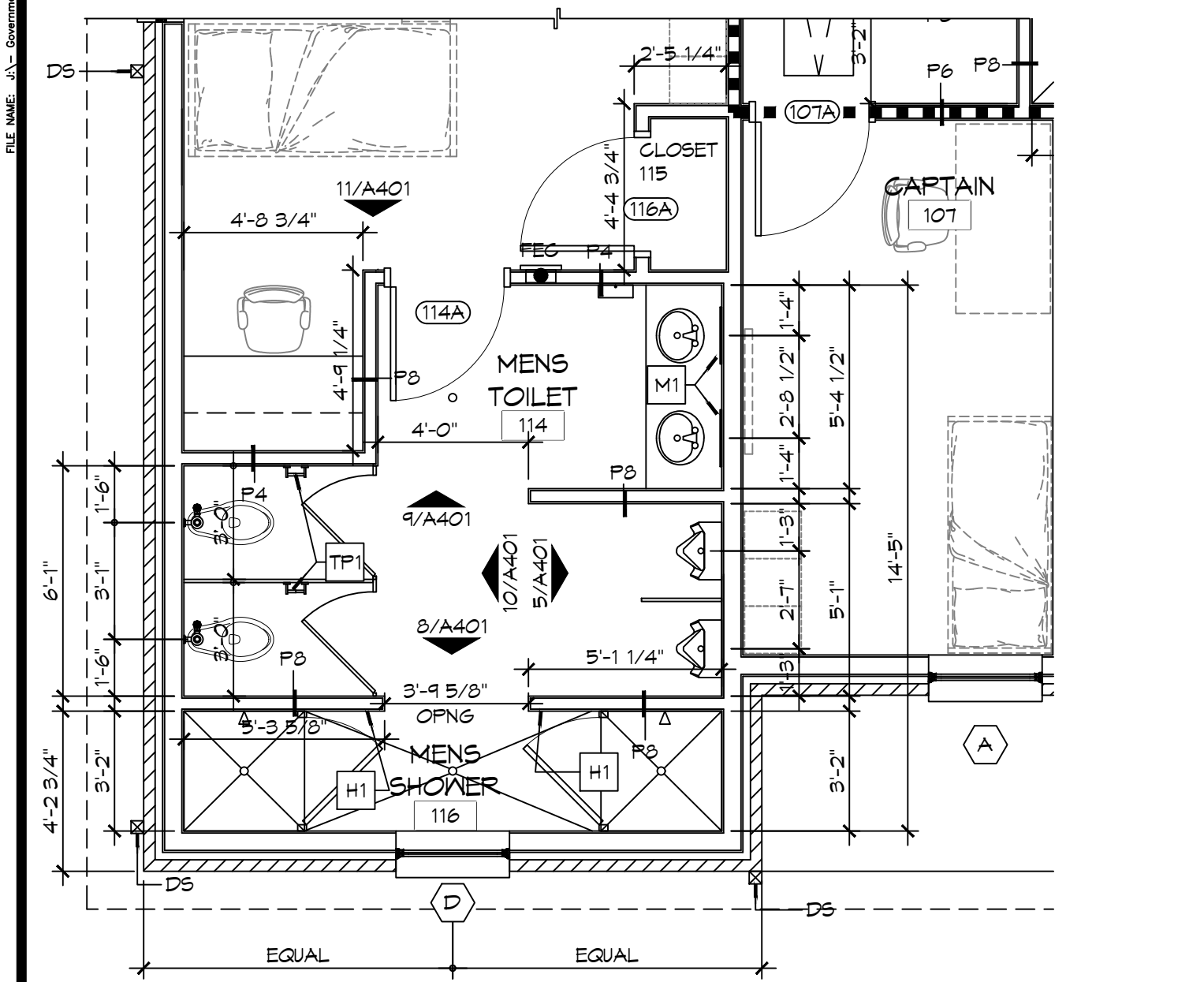
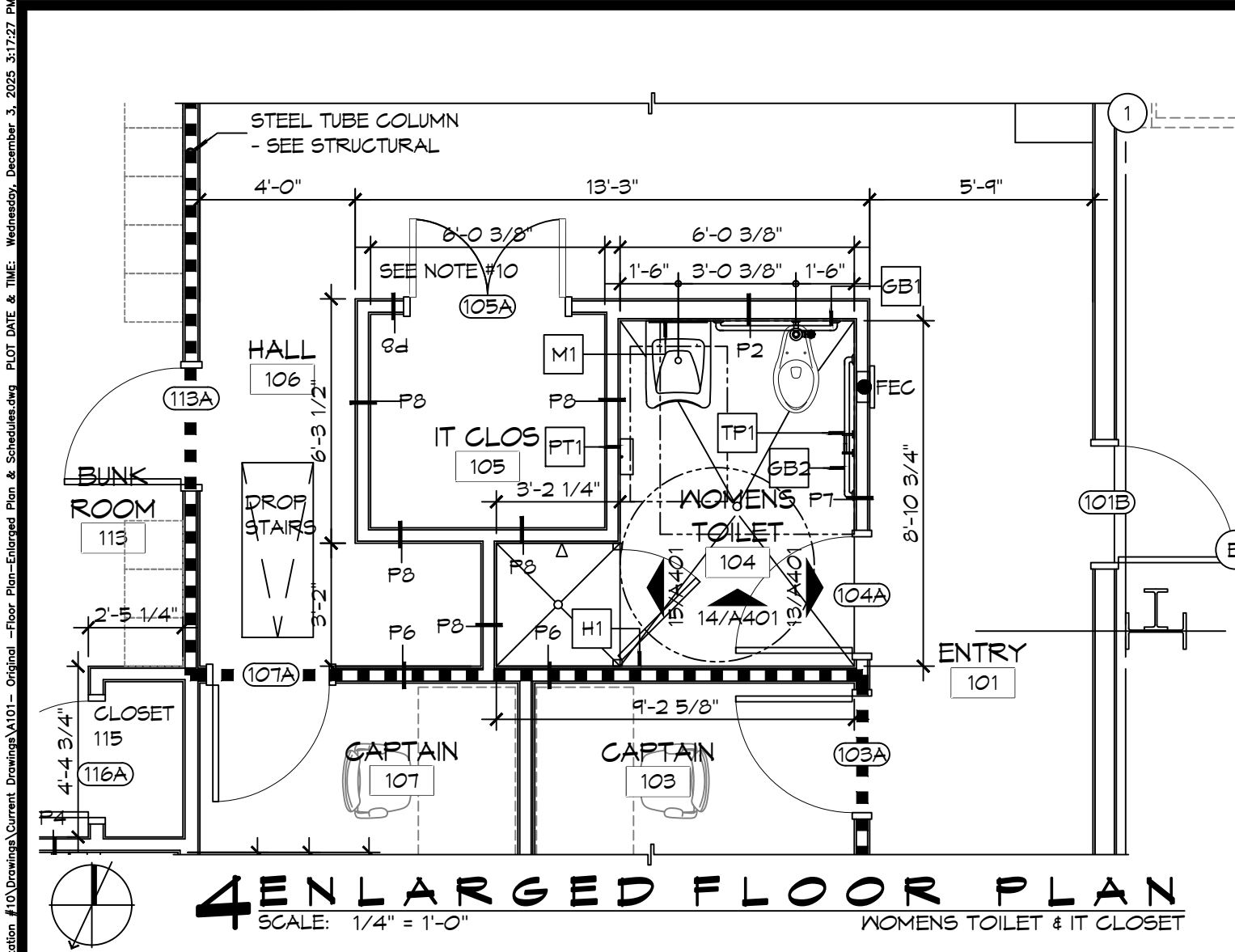

FINISH SCHEDULE

ROOM	RM #	FLOOR	BASE	WALLS				CEILING	NOTES
				NORTH	EAST	SOUTH	WEST		
ENTRY	101	CERAMIC TILE	5" RUBBER	5/8" GNB	5/8" GNB	5/8" GNB	5/8" GNB	5/8" GNB	3' X 6' CERAMIC TILE SD15, GROUT 66 CHESTNUT, 5" RUBBER BASE 170 PEPPER
DAY ROOM	102	CERAMIC TILE	5" RUBBER	5/8" GNB	5/8" GNB	5/8" GNB	5/8" GNB	5/8" GNB	3' X 6' CERAMIC TILE SD15, GROUT 66 CHESTNUT, 5" RUBBER BASE 170 PEPPER
CAPTAIN	103	CERAMIC TILE	5" RUBBER	5/8" GNB	5/8" GNB	5/8" GNB	5/8" GNB	5/8" GNB	3' X 6' CERAMIC TILE SD15, GROUT 66 CHESTNUT, 5" RUBBER BASE 170 PEPPER
WOMENS TOILET	104	CERAMIC TILE	5" RUBBER	5/8" MR GNB	5/8" MR GNB	5/8" MR GNB	5/8" MR GNB	5/8" MR GNB	3' X 6' CERAMIC TILE SD15, GROUT 66 CHESTNUT, 5" RUBBER BASE 170 PEPPER
IT CLOSET	105	CERAMIC TILE	5" RUBBER	5/8" GNB	5/8" GNB	5/8" GNB	5/8" GNB	5/8" GNB	3' X 6' CERAMIC TILE SD15, GROUT 66 CHESTNUT, 5" RUBBER BASE 170 PEPPER
HALL	106	CERAMIC TILE	5" RUBBER	5/8" GNB	5/8" GNB	5/8" GNB	5/8" GNB	5/8" GNB	3' X 6' CERAMIC TILE SD15, GROUT 66 CHESTNUT, 5" RUBBER BASE 170 PEPPER
CAPTAIN	107	CERAMIC TILE	5" RUBBER	5/8" GNB	5/8" GNB	5/8" GNB	5/8" GNB	5/8" GNB	3' X 6' CERAMIC TILE SD15, GROUT 66 CHESTNUT, 5" RUBBER BASE 170 PEPPER
KITCHEN	108	CERAMIC TILE	5" RUBBER	5/8" GNB	5/8" GNB	5/8" GNB	5/8" GNB	5/8" GNB	3' X 6' CERAMIC TILE SD15, GROUT 66 CHESTNUT, 5" RUBBER BASE 170 PEPPER
DINING ROOM	109	CERAMIC TILE	5" RUBBER	5/8" GNB	5/8" GNB	5/8" GNB	5/8" GNB	5/8" GNB	3' X 6' CERAMIC TILE SD15, GROUT 66 CHESTNUT, 5" RUBBER BASE 170 PEPPER
PANTRY	110	CERAMIC TILE	5" RUBBER	5/8" GNB	5/8" GNB	5/8" GNB	5/8" GNB	5/8" GNB	3' X 6' CERAMIC TILE SD15, GROUT 66 CHESTNUT, 5" RUBBER BASE 170 PEPPER
PANTRY	111	CERAMIC TILE	5" RUBBER	5/8" GNB	5/8" GNB	5/8" GNB	5/8" GNB	5/8" GNB	3' X 6' CERAMIC TILE SD15, GROUT 66 CHESTNUT, 5" RUBBER BASE 170 PEPPER
PANTRY	112	CERAMIC TILE	5" RUBBER	5/8" GNB	5/8" GNB	5/8" GNB	5/8" GNB	5/8" GNB	3' X 6' CERAMIC TILE SD15, GROUT 66 CHESTNUT, 5" RUBBER BASE 170 PEPPER
BUNK ROOM	113	CERAMIC TILE	5" RUBBER	5/8" GNB	5/8" GNB	5/8" GNB	5/8" GNB	5/8" GNB	3' X 6' CERAMIC TILE SD15, GROUT 66 CHESTNUT, 5" RUBBER BASE 170 PEPPER
MENS TOILET	114	CERAMIC TILE	5" RUBBER	5/8" MR GNB	5/8" MR GNB	5/8" MR GNB	5/8" MR GNB	5/8" MR GNB	3' X 6' CERAMIC TILE SD15, GROUT 66 CHESTNUT, 5" RUBBER BASE 170 PEPPER
CLOSET	115	CERAMIC TILE	5" RUBBER	5/8" MR GNB	5/8" MR GNB	5/8" MR GNB	5/8" MR GNB	5/8" MR GNB	3' X 6' CERAMIC TILE SD15, GROUT 66 CHESTNUT, 5" RUBBER BASE 170 PEPPER
MENS SHOWER	116	CERAMIC TILE	5" RUBBER	5/8" MR GNB	5/8" MR GNB	5/8" MR GNB	5/8" MR GNB	5/8" MR GNB	3' X 6' CERAMIC TILE SD15, GROUT 66 CHESTNUT, 5" RUBBER BASE 170 PEPPER
APPARATUS BAYS	117	EPOXY	6' CEMENTITIOUS	MTL LINER PANEL	MTL LINER PANEL	MTL LINER PANEL	MTL LINER PANEL	MTL LINER PANEL	
UTILITY ROOM	118	EPOXY	5" RUBBER	5/8" MR GNB	5/8" MR GNB	5/8" MR GNB	5/8" MR GNB	5/8" MR GNB	5" RUBBER BASE 170 PEPPER
RESTROOM	119	EPOXY	TILE	5/8" MR GNB	5/8" MR GNB	5/8" MR GNB	5/8" MR GNB	5/8" MR GNB	
STORAGE 1	120	SEALED CONC	5" RUBBER	5/8" MR GNB	5/8" MR GNB	5/8" MR GNB	5/8" MR GNB	5/8" MR GNB	5" RUBBER BASE 170 PEPPER
MAINTENANCE BAY	121	EPOXY	6' CEMENTITIOUS	MTL LINER PANEL	MTL LINER PANEL	MTL LINER PANEL	MTL LINER PANEL	MTL LINER PANEL	
MECH/ELEC	122	SEALED CONC	5" RUBBER	5/8" MR GNB	5/8" MR GNB	5/8" MR GNB	5/8" MR GNB	5/8" MR GNB	5" RUBBER BASE 170 PEPPER
GEAR ROOM	123	SEALED CONC	5" RUBBER	5/8" MR GNB	5/8" MR GNB	5/8" MR GNB	5/8" MR GNB	5/8" MR GNB	5" RUBBER BASE 170 PEPPER
STORAGE 2	124	SEALED CONC	5" RUBBER	5/8" MR GNB	5/8" MR GNB	5/8" MR GNB	5/8" MR GNB	5/8" MR GNB	5" RUBBER BASE 170 PEPPER

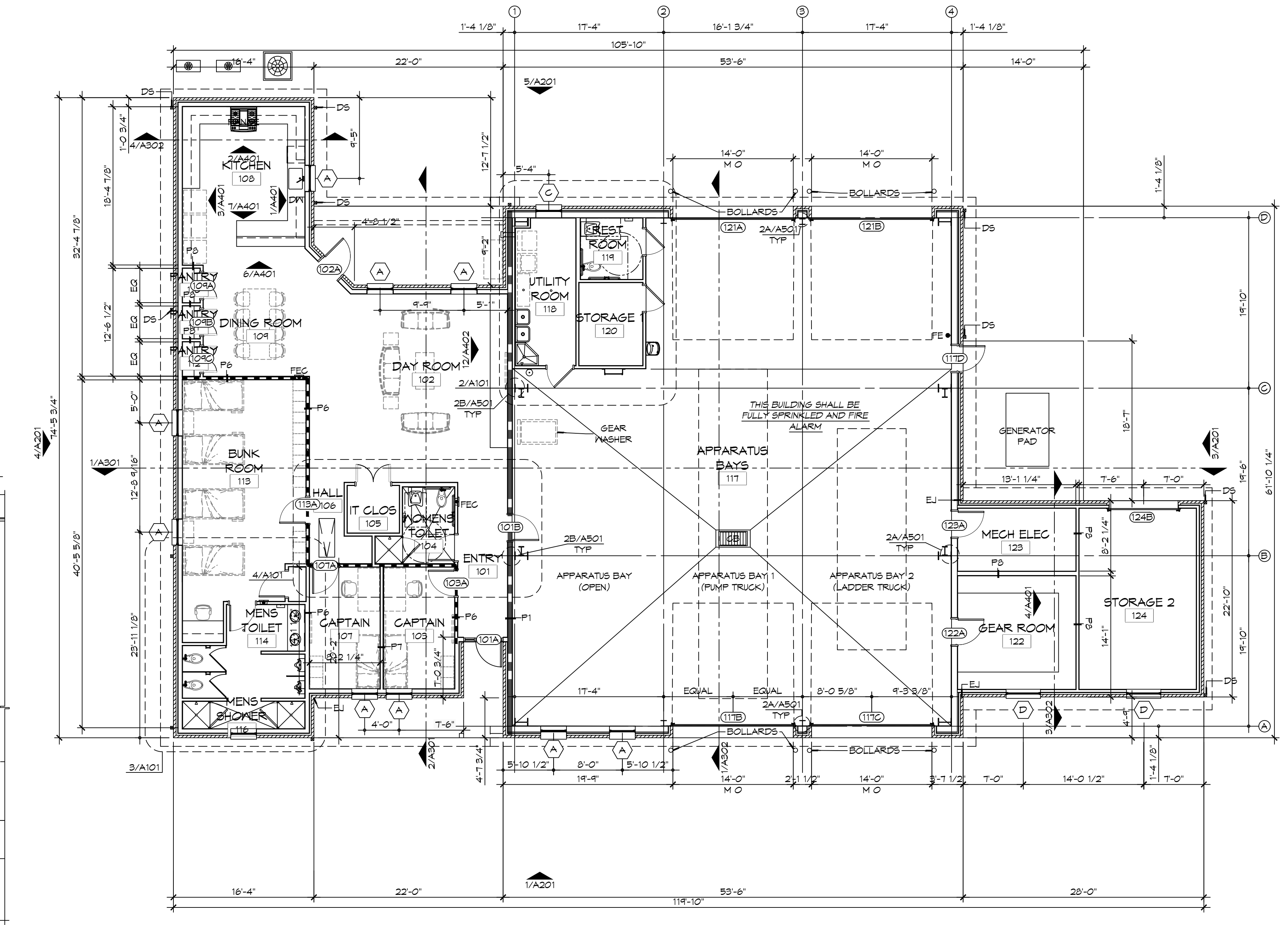

- ### GENERAL SHEET NOTES
- ALL DIMENSIONS ARE FACE-OF-WALL TO FACE-OF-WALL UNLESS NOTED OTHERWISE.
 - ALL PLUMBING FIXTURES, FURNITURE, AND APPLIANCES THAT ARE SHOWN AS GRAYED AND DASHED ARE TO BE OWNER PROVIDED AND NOT IN CONTRACT (NIC) AND ARE SHOWN FOR COORDINATION PURPOSES ONLY. CONTRACTOR TO VERIFY THOSE ITEMS OWNER FURNISHED AND CONTRACTOR INSTALLED (OFCI).
 - PROVIDE FIVE MELONINE-GLAD WOOD SHELVES IN CLOSET 115.
 - REFER TO PARTITION TYPES FOR PARTITION THICKNESS WHERE NOT SHOWN ON PLAN.
 - ALL MANUFACTURED ARTICLES, MATERIALS, AND EQUIPMENT SHALL BE CONDITIONED, USED APPLIED, INSTALLED, CONNECTED, ERECTED, AND CLEANED IN ACCORDANCE WITH THE MANUFACTURERS WRITTEN SPECIFICATIONS OR INSTRUCTIONS.
 - FOR ALL WOOD MEMBERS REQUIRED BY CODE TO BE FIRE RETARDANT TREATED, PROVIDE PRESSURE IMPREGNATION WITH FIRE RETARDANT CHEMICALS TO PROVIDE UL FRS FIRE HAZARD CLASSIFICATION. ALL WOOD SHALL BE IDENTIFIED WITH A UL LABEL CERTIFYING THIS CLASSIFICATION AND FM DIAMOND.
 - GENERAL CONTRACTOR TO PROVIDE FIVE POUND "ABC" RATED FIRE EXTINGUISHER(S) AND/OR CABINET(S) WHERE SHOWN ON THESE PLANS.
 - ALL PENETRATIONS OF FIRE RESISTIVE FLOORS OR SHAFT WALLS SHALL BE PROTECTED BY MATERIALS AND INSTALLATION DETAILS THAT CONFORM TO UL STANDARDS FOR THROUGH PENETRATIONS FIRESTOP SYSTEMS. SEAL AROUND ALL PENETRATIONS (DUCTS, PIPES, CONDUITS, ETC) AT FIRE-RATED ASSEMBLIES. SEAL SHALL NOT DIMINISH RATING OF ASSEMBLY. AT CONCRETE OR MASONRY, SEAL OFF OPENINGS WITH CONCRETE GROUT. AT PLASTER OR DRYWALL, DAM UP GAPS AND FILL WITH UL APPROVED SEALANT OR PUTTY PER MANUFACTURERS RECOMMENDATIONS.
 - WRAP AROUND ALL ARCHITECTURAL, MECHANICAL, OR ELECTRICAL BOXES, RECESSED/PENETRATED INTO ANY FIRE-RATED WALLS WITH 5/8" TYPE "X" GYPSUM BOARD UNLESS WALL IS OF CONCRETE CONSTRUCTION.
 - PROVIDE 4x8x3/4" BC PLYWOOD ON THREE WALLS FOR ATTACHMENT OF IT EQUIPMENT IN IT CLOSET 105. INSTALL PLYWOOD PANELS VERTICALLY TIGHT TO FINISH CEILING.
 - NOT USED.
 - SEE PROJECT SPECIFICATIONS FOR TOILET ACCESSORY HARDWARE SCHEDULE.
 - SEE SHEET A201 FOR MASONRY EXPANSION JOINT LOCATIONS NOT SHOWN ON THIS SHEET.

LEGEND

	FIRE-RATED PARTITION - SEE PARTITION TYPES AND LIFE-SAFETY PLAN FOR DESIGNATED FIRE RATING
	SMOKE PARTITION - SEE PARTITION TYPES AND LIFE-SAFETY PLAN FOR DESIGNATED RATING

DAMMON

ENGINEERING, INC.

LOUISIANA & MISSISSIPPI

Chief Engineer: Brian Missetch, PE
554 Old Spanish Trail
Slidell, LA 70688
www.dammonengineering.com
info@dammonengineering.com
PH: 985.649.5832

REVISIONS	DATE

#	DESCRIPTION

NEW FIRE STATION #10
ST. TAMMANY FIRE PROTECTION DISTRICT NO. 1

248 LAKESHORE VISTA BLVD
SLIDELL, LA 70661

JMS
DATE: 12-05-2025
JOB No: 2519
DRAWN BY: GKD
CHECKED BY: JMS

SHEET TITLE:
ARCHITECTURAL FLOOR PLAN, DETAIL FLOOR PLANS, AND SCHEDULES

DRAWING NUMBER:
A101

SHEET No: 10 of 37

FILE NAME: J:\Projects\2019\2019-05-20\2019-05-20\2019-05-20.dwg PLOT DATE: 12/10/2025 1:13:32 PM

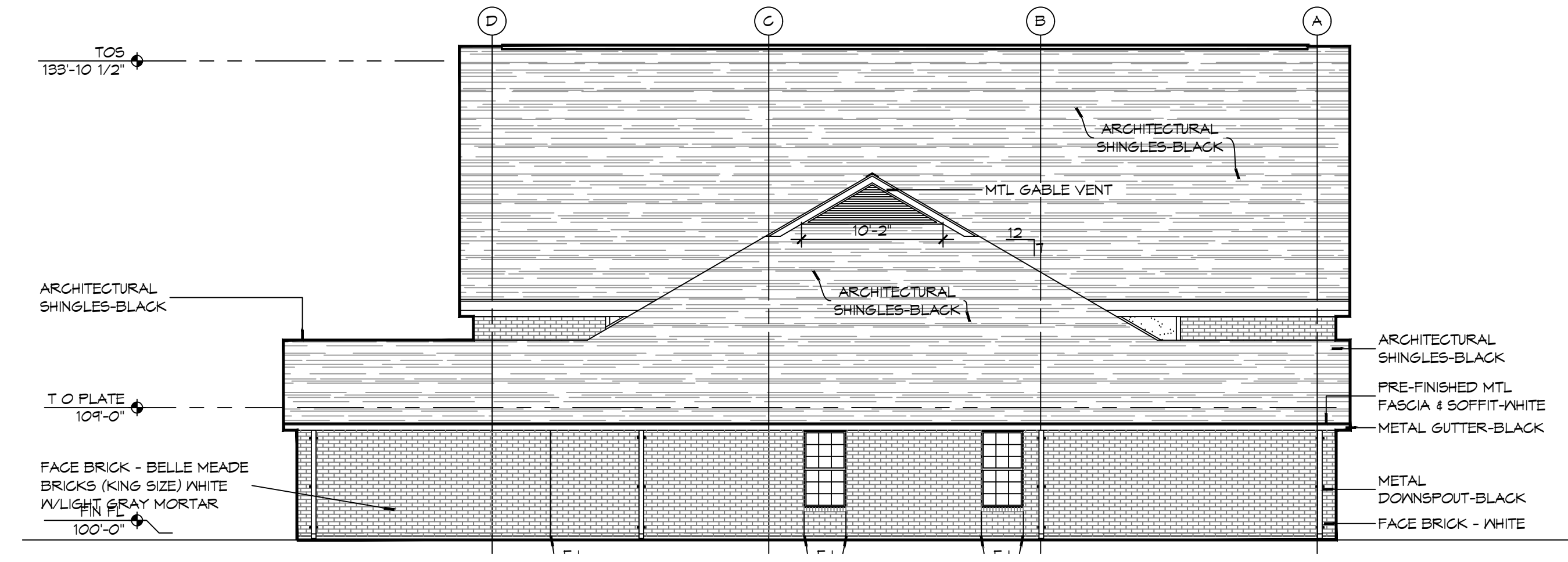

4 EXTERIOR ELEVATION LEFT SIDE
SCALE: 1/8" = 1'-0" EAST

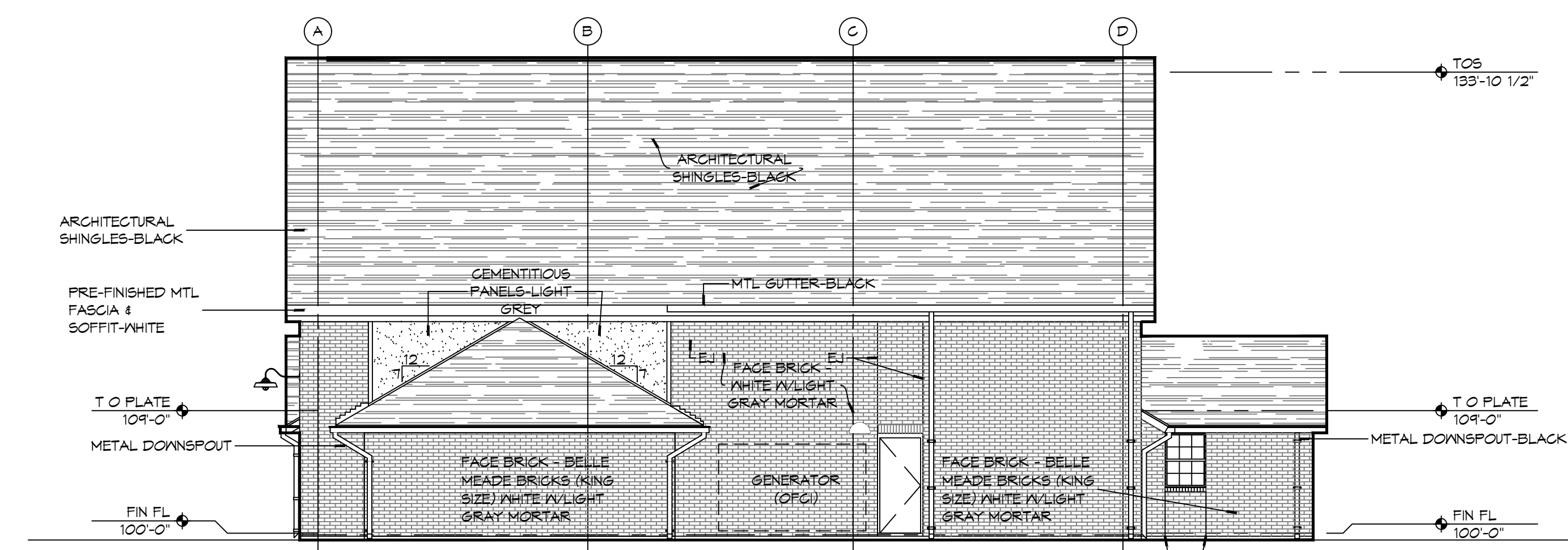

3 EXTERIOR ELEVATION RIGHT SIDE
SCALE: 1/8" = 1'-0" WEST

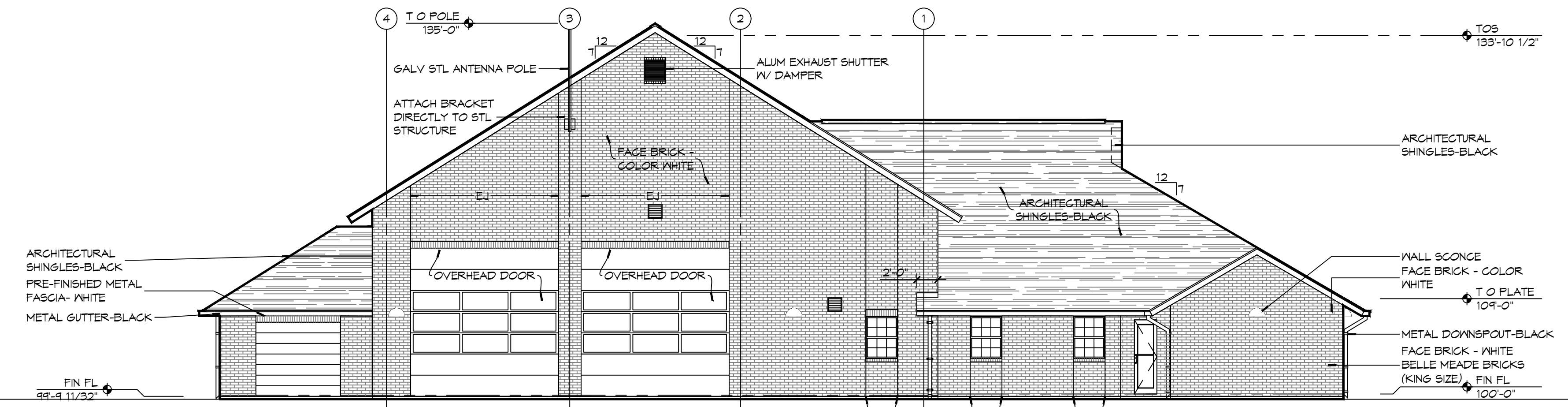

2 EXTERIOR ELEVATION REAR SIDE
SCALE: 1/8" = 1'-0" EAST

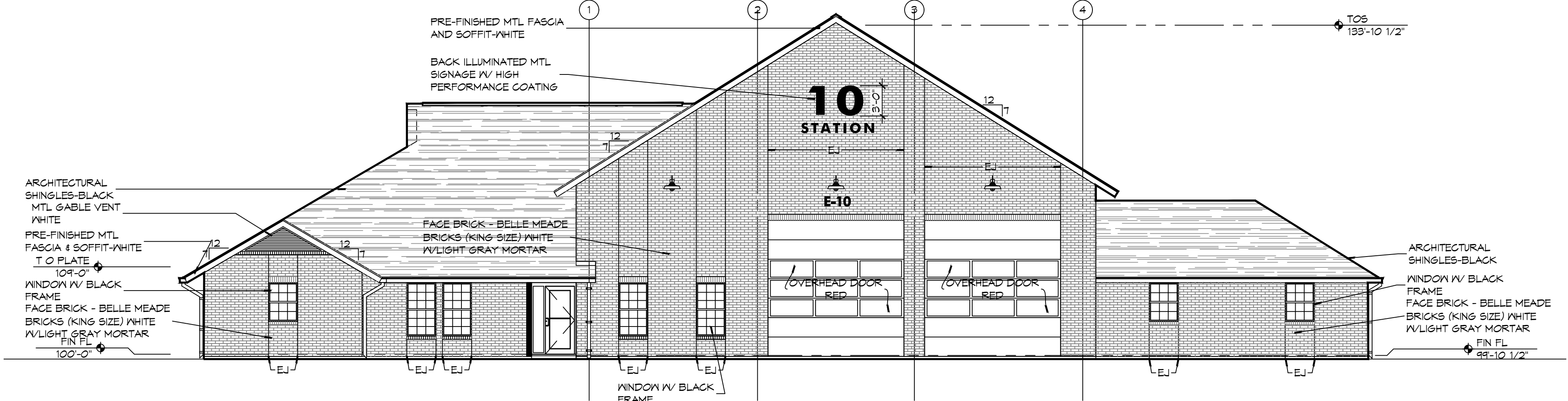

1 EXTERIOR ELEVATION FRONT SIDE
SCALE: 1/8" = 1'-0" NORTH

GENERAL ELEVATION NOTES

1. REFER TO SHEET A101 FOR WINDOW TYPE ELEVATIONS.
2. WINDOW TYPES NOT INDICATED THIS SHEET ARE IDENTIFIED ON SHEET A501.
3. CONTRACTOR SHALL REVIEW LOCATIONS AND INTENT OF ALL MASONRY EXPANSION/CONTROL JOINTS WITH ARCHITECT PRIOR TO CONSTRUCTION. REFER TO ELEVATIONS FOR INDICATED JOINT LOCATIONS. LAY PINE STRAIN DOWN TO AVOID RAINWATER SPLASHING RED CLAY ONTO BRICK.
4. SEE 8/A501 FOR TYPICAL MASONRY EXPANSION JOINT DETAILS.
5. MASONRY DIMENSIONS ARE NOMINAL.
6. ALL FLASHING SHALL BE DONE IN STRICT ACCORDANCE WITH THE FLASHING MANUFACTURER'S PUBLISHED SPECIFICATIONS AND DETAILS. THIS TO INCLUDE AMOUNT OF OVERLAP AND INSTALLATION OF DRIP EDGES, IF REQUIRED.
7. LINE OF FINISH GRADE ON EXTERIOR ELEVATIONS IS APPROXIMATE AND ARE INTENDED FOR REFERENCE PURPOSES ONLY. REFER TO CIVIL GRADING PLAN FOR FINISH GRADE ELEVATIONS.
8. SEE SHEET A101 FOR EXPANSION JOINTS (EJ) IN HIDDEN LOCATIONS AND NOT SHOWN ON THIS SHEET.

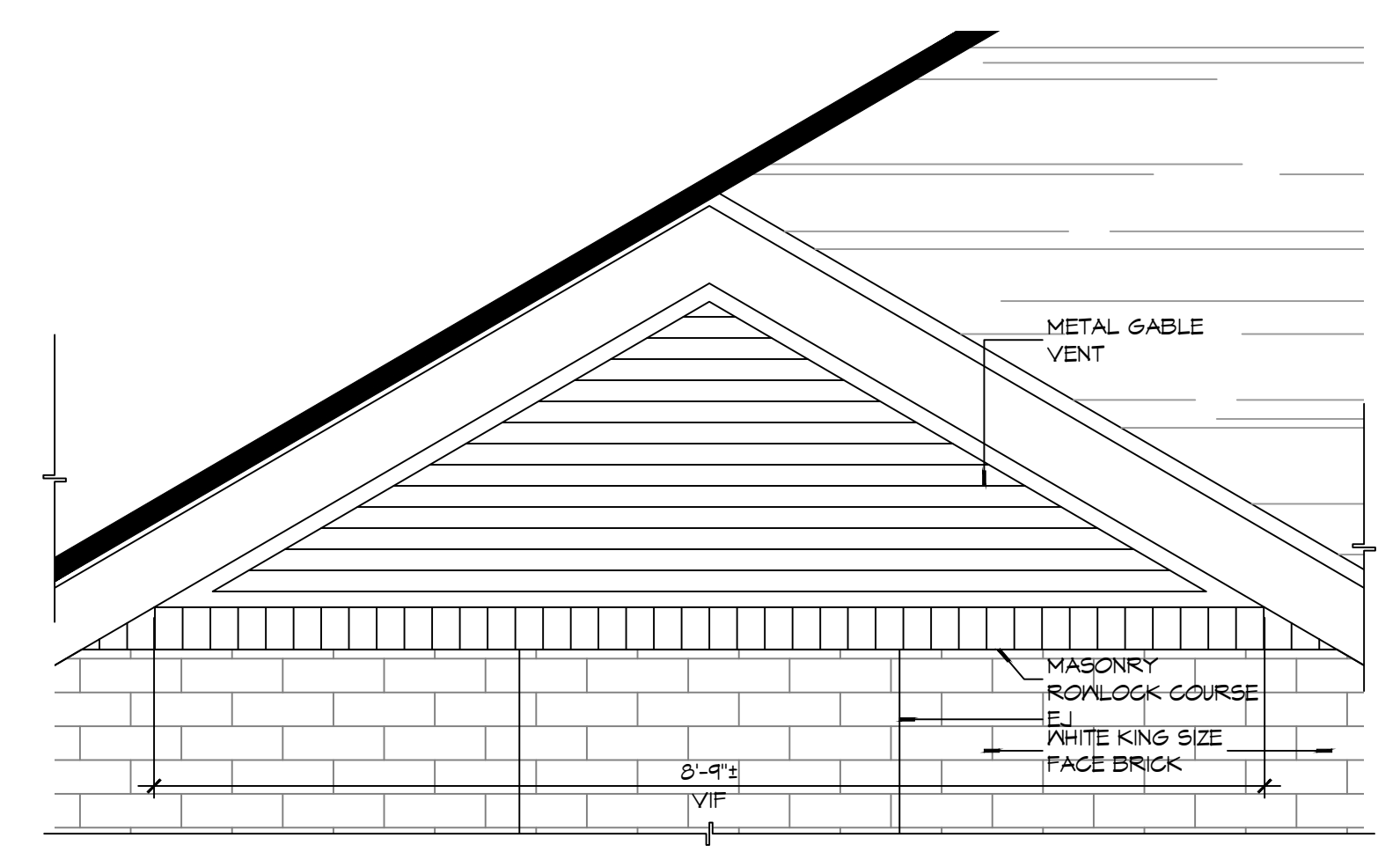

6 DETAIL ELEVATION
SCALE: 3/4" = 1'-0" GABLE VENT

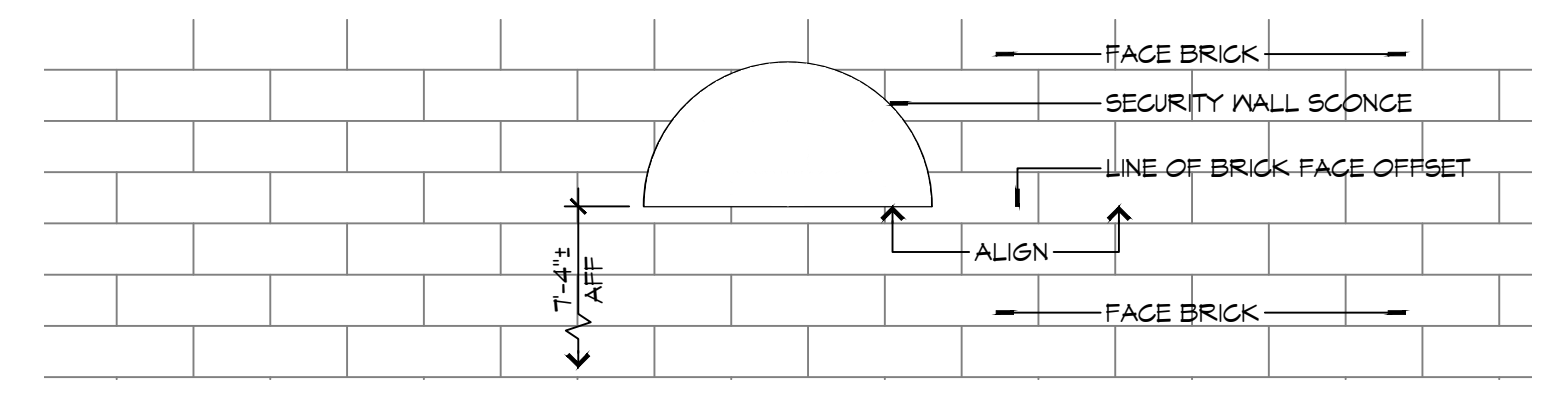

5 DETAIL ELEVATION
SCALE: 1" = 1'-0" EXTERIOR WALL SCENCE MOUNTING HEIGHT

DAMMON ENGINEERING, INC.
LOUISIANA & MISSISSIPPI

Chief Engineer: Brian Mistich, PE
554 Old Spanish Trail
Slidell, LA 70458
www.dammonengineering.com
info@dammonengineering.com
PH: 985.649.5832

#	DESCRIPTION	DATE

SEAL:

NEW FIRE STATION #10
ST. TAMMANY FIRE PROTECTION DISTRICT NO. 1

248 LAKESHORE VISTA BLVD
SLIDELL, LA 70461
JOB No: 2519 DATE: 12-05-2025
DRAWN BY: CKD CHECKED BY: JMS

SHEET TITLE:
BUILDING ELEVATIONS

DRAWING NUMBER:
A201

FILE NAME: A:\1 - Government\13119 - Fire Station 410\Drawings\Crossed Dammon\A301.dwg, A302.dwg, A303.dwg, A304.dwg, A305.dwg, A306.dwg, A307.dwg, A308.dwg, A309.dwg, A310.dwg, A311.dwg, A312.dwg, A313.dwg, A314.dwg, A315.dwg, A316.dwg, A317.dwg, A318.dwg, A319.dwg, A320.dwg, A321.dwg, A322.dwg, A323.dwg, A324.dwg, A325.dwg, A326.dwg, A327.dwg, A328.dwg, A329.dwg, A330.dwg, A331.dwg, A332.dwg, A333.dwg, A334.dwg, A335.dwg, A336.dwg, A337.dwg, A338.dwg, A339.dwg, A340.dwg, A341.dwg, A342.dwg, A343.dwg, A344.dwg, A345.dwg, A346.dwg, A347.dwg, A348.dwg, A349.dwg, A350.dwg, A351.dwg, A352.dwg, A353.dwg, A354.dwg, A355.dwg, A356.dwg, A357.dwg, A358.dwg, A359.dwg, A360.dwg, A361.dwg, A362.dwg, A363.dwg, A364.dwg, A365.dwg, A366.dwg, A367.dwg, A368.dwg, A369.dwg, A370.dwg, A371.dwg, A372.dwg, A373.dwg, A374.dwg, A375.dwg, A376.dwg, A377.dwg, A378.dwg, A379.dwg, A380.dwg, A381.dwg, A382.dwg, A383.dwg, A384.dwg, A385.dwg, A386.dwg, A387.dwg, A388.dwg, A389.dwg, A390.dwg, A391.dwg, A392.dwg, A393.dwg, A394.dwg, A395.dwg, A396.dwg, A397.dwg, A398.dwg, A399.dwg, A400.dwg, A401.dwg, A402.dwg, A403.dwg, A404.dwg, A405.dwg, A406.dwg, A407.dwg, A408.dwg, A409.dwg, A410.dwg, A411.dwg, A412.dwg, A413.dwg, A414.dwg, A415.dwg, A416.dwg, A417.dwg, A418.dwg, A419.dwg, A420.dwg, A421.dwg, A422.dwg, A423.dwg, A424.dwg, A425.dwg, A426.dwg, A427.dwg, A428.dwg, A429.dwg, A430.dwg, A431.dwg, A432.dwg, A433.dwg, A434.dwg, A435.dwg, A436.dwg, A437.dwg, A438.dwg, A439.dwg, A440.dwg, A441.dwg, A442.dwg, A443.dwg, A444.dwg, A445.dwg, A446.dwg, A447.dwg, A448.dwg, A449.dwg, A450.dwg, A451.dwg, A452.dwg, A453.dwg, A454.dwg, A455.dwg, A456.dwg, A457.dwg, A458.dwg, A459.dwg, A460.dwg, A461.dwg, A462.dwg, A463.dwg, A464.dwg, A465.dwg, A466.dwg, A467.dwg, A468.dwg, A469.dwg, A470.dwg, A471.dwg, A472.dwg, A473.dwg, A474.dwg, A475.dwg, A476.dwg, A477.dwg, A478.dwg, A479.dwg, A480.dwg, A481.dwg, A482.dwg, A483.dwg, A484.dwg, A485.dwg, A486.dwg, A487.dwg, A488.dwg, A489.dwg, A490.dwg, A491.dwg, A492.dwg, A493.dwg, A494.dwg, A495.dwg, A496.dwg, A497.dwg, A498.dwg, A499.dwg, A500.dwg, A501.dwg, A502.dwg, A503.dwg, A504.dwg, A505.dwg, A506.dwg, A507.dwg, A508.dwg, A509.dwg, A510.dwg, A511.dwg, A512.dwg, A513.dwg, A514.dwg, A515.dwg, A516.dwg, A517.dwg, A518.dwg, A519.dwg, A520.dwg, A521.dwg, A522.dwg, A523.dwg, A524.dwg, A525.dwg, A526.dwg, A527.dwg, A528.dwg, A529.dwg, A530.dwg, A531.dwg, A532.dwg, A533.dwg, A534.dwg, A535.dwg, A536.dwg, A537.dwg, A538.dwg, A539.dwg, A540.dwg, A541.dwg, A542.dwg, A543.dwg, A544.dwg, A545.dwg, A546.dwg, A547.dwg, A548.dwg, A549.dwg, A550.dwg, A551.dwg, A552.dwg, A553.dwg, A554.dwg, A555.dwg, A556.dwg, A557.dwg, A558.dwg, A559.dwg, A560.dwg, A561.dwg, A562.dwg, A563.dwg, A564.dwg, A565.dwg, A566.dwg, A567.dwg, A568.dwg, A569.dwg, A570.dwg, A571.dwg, A572.dwg, A573.dwg, A574.dwg, A575.dwg, A576.dwg, A577.dwg, A578.dwg, A579.dwg, A580.dwg, A581.dwg, A582.dwg, A583.dwg, A584.dwg, A585.dwg, A586.dwg, A587.dwg, A588.dwg, A589.dwg, A590.dwg, A591.dwg, A592.dwg, A593.dwg, A594.dwg, A595.dwg, A596.dwg, A597.dwg, A598.dwg, A599.dwg, A600.dwg, A601.dwg, A602.dwg, A603.dwg, A604.dwg, A605.dwg, A606.dwg, A607.dwg, A608.dwg, A609.dwg, A610.dwg, A611.dwg, A612.dwg, A613.dwg, A614.dwg, A615.dwg, A616.dwg, A617.dwg, A618.dwg, A619.dwg, A620.dwg, A621.dwg, A622.dwg, A623.dwg, A624.dwg, A625.dwg, A626.dwg, A627.dwg, A628.dwg, A629.dwg, A630.dwg, A631.dwg, A632.dwg, A633.dwg, A634.dwg, A635.dwg, A636.dwg, A637.dwg, A638.dwg, A639.dwg, A640.dwg, A641.dwg, A642.dwg, A643.dwg, A644.dwg, A645.dwg, A646.dwg, A647.dwg, A648.dwg, A649.dwg, A650.dwg, A651.dwg, A652.dwg, A653.dwg, A654.dwg, A655.dwg, A656.dwg, A657.dwg, A658.dwg, A659.dwg, A660.dwg, A661.dwg, A662.dwg, A663.dwg, A664.dwg, A665.dwg, A666.dwg, A667.dwg, A668.dwg, A669.dwg, A670.dwg, A671.dwg, A672.dwg, A673.dwg, A674.dwg, A675.dwg, A676.dwg, A677.dwg, A678.dwg, A679.dwg, A680.dwg, A681.dwg, A682.dwg, A683.dwg, A684.dwg, A685.dwg, A686.dwg, A687.dwg, A688.dwg, A689.dwg, A690.dwg, A691.dwg, A692.dwg, A693.dwg, A694.dwg, A695.dwg, A696.dwg, A697.dwg, A698.dwg, A699.dwg, A700.dwg, A701.dwg, A702.dwg, A703.dwg, A704.dwg, A705.dwg, A706.dwg, A707.dwg, A708.dwg, A709.dwg, A710.dwg, A711.dwg, A712.dwg, A713.dwg, A714.dwg, A715.dwg, A716.dwg, A717.dwg, A718.dwg, A719.dwg, A720.dwg, A721.dwg, A722.dwg, A723.dwg, A724.dwg, A725.dwg, A726.dwg, A727.dwg, A728.dwg, A729.dwg, A730.dwg, A731.dwg, A732.dwg, A733.dwg, A734.dwg, A735.dwg, A736.dwg, A737.dwg, A738.dwg, A739.dwg, A740.dwg, A741.dwg, A742.dwg, A743.dwg, A744.dwg, A745.dwg, A746.dwg, A747.dwg, A748.dwg, A749.dwg, A750.dwg, A751.dwg, A752.dwg, A753.dwg, A754.dwg, A755.dwg, A756.dwg, A757.dwg, A758.dwg, A759.dwg, A760.dwg, A761.dwg, A762.dwg, A763.dwg, A764.dwg, A765.dwg, A766.dwg, A767.dwg, A768.dwg, A769.dwg, A770.dwg, A771.dwg, A772.dwg, A773.dwg, A774.dwg, A775.dwg, A776.dwg, A777.dwg, A778.dwg, A779.dwg, A780.dwg, A781.dwg, A782.dwg, A783.dwg, A784.dwg, A785.dwg, A786.dwg, A787.dwg, A788.dwg, A789.dwg, A790.dwg, A791.dwg, A792.dwg, A793.dwg, A794.dwg, A795.dwg, A796.dwg, A797.dwg, A798.dwg, A799.dwg, A800.dwg, A801.dwg, A802.dwg, A803.dwg, A804.dwg, A805.dwg, A806.dwg, A807.dwg, A808.dwg, A809.dwg, A810.dwg, A811.dwg, A812.dwg, A813.dwg, A814.dwg, A815.dwg, A816.dwg, A817.dwg, A818.dwg, A819.dwg, A820.dwg, A821.dwg, A822.dwg, A823.dwg, A824.dwg, A825.dwg, A826.dwg, A827.dwg, A828.dwg, A829.dwg, A830.dwg, A831.dwg, A832.dwg, A833.dwg, A834.dwg, A835.dwg, A836.dwg, A837.dwg, A838.dwg, A839.dwg, A840.dwg, A841.dwg, A842.dwg, A843.dwg, A844.dwg, A845.dwg, A846.dwg, A847.dwg, A848.dwg, A849.dwg, A850.dwg, A851.dwg, A852.dwg, A853.dwg, A854.dwg, A855.dwg, A856.dwg, A857.dwg, A858.dwg, A859.dwg, A860.dwg, A861.dwg, A862.dwg, A863.dwg, A864.dwg, A865.dwg, A866.dwg, A867.dwg, A868.dwg, A869.dwg, A870.dwg, A871.dwg, A872.dwg, A873.dwg, A874.dwg, A875.dwg, A876.dwg, A877.dwg, A878.dwg, A879.dwg, A880.dwg, A881.dwg, A882.dwg, A883.dwg, A884.dwg, A885.dwg, A886.dwg, A887.dwg, A888.dwg, A889.dwg, A890.dwg, A891.dwg, A892.dwg, A893.dwg, A894.dwg, A895.dwg, A896.dwg, A897.dwg, A898.dwg, A899.dwg, A900.dwg, A901.dwg, A902.dwg, A903.dwg, A904.dwg, A905.dwg, A906.dwg, A907.dwg, A908.dwg, A909.dwg, A910.dwg, A911.dwg, A912.dwg, A913.dwg, A914.dwg, A915.dwg, A916.dwg, A917.dwg, A918.dwg, A919.dwg, A920.dwg, A921.dwg, A922.dwg, A923.dwg, A924.dwg, A925.dwg, A926.dwg, A927.dwg, A928.dwg, A929.dwg, A930.dwg, A931.dwg, A932.dwg, A933.dwg, A934.dwg, A935.dwg, A936.dwg, A937.dwg, A938.dwg, A939.dwg, A940.dwg, A941.dwg, A942.dwg, A943.dwg, A944.dwg, A945.dwg, A946.dwg, A947.dwg, A948.dwg, A949.dwg, A950.dwg, A951.dwg, A952.dwg, A953.dwg, A954.dwg, A955.dwg, A956.dwg, A957.dwg, A958.dwg, A959.dwg, A960.dwg, A961.dwg, A962.dwg, A963.dwg, A964.dwg, A965.dwg, A966.dwg, A967.dwg, A968.dwg, A969.dwg, A970.dwg, A971.dwg, A972.dwg, A973.dwg, A974.dwg, A975.dwg, A976.dwg, A977.dwg, A978.dwg, A979.dwg, A980.dwg, A981.dwg, A982.dwg, A983.dwg, A984.dwg, A985.dwg, A986.dwg, A987.dwg, A988.dwg, A989.dwg, A990.dwg, A991.dwg, A992.dwg, A993.dwg, A994.dwg, A995.dwg, A996.dwg, A997.dwg, A998.dwg, A999.dwg, A1000.dwg

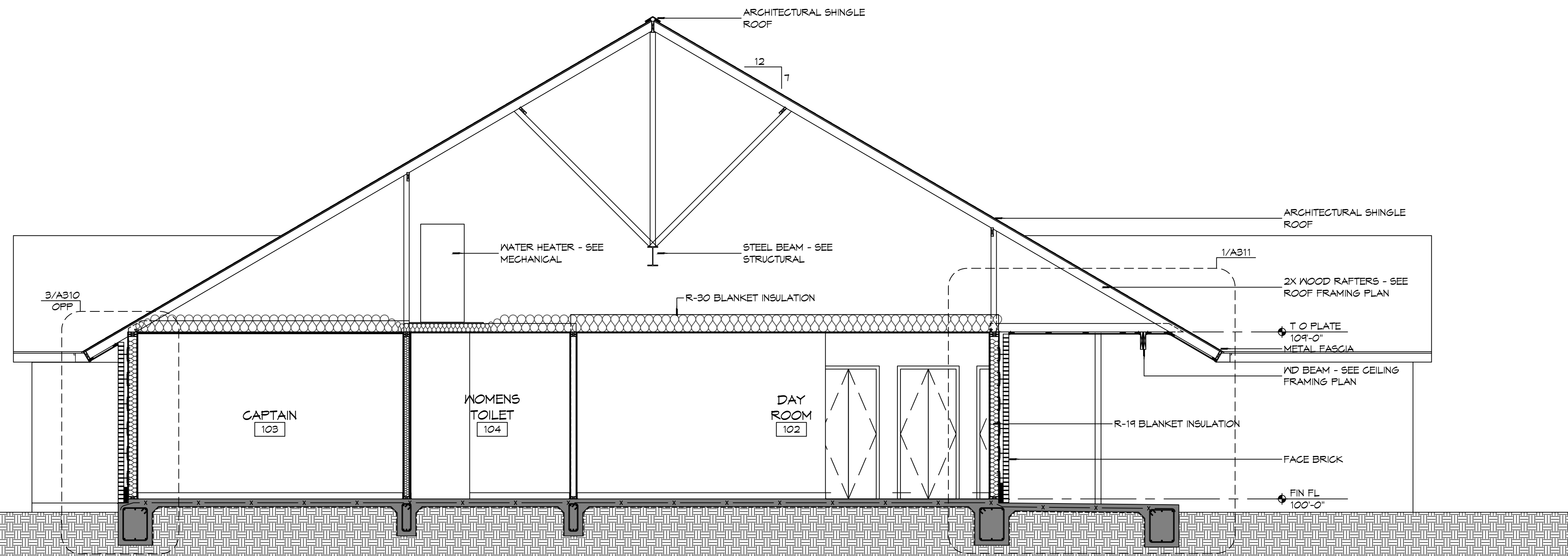

2 BUILDING SECTION
SCALE: 1/4" = 1'-0"

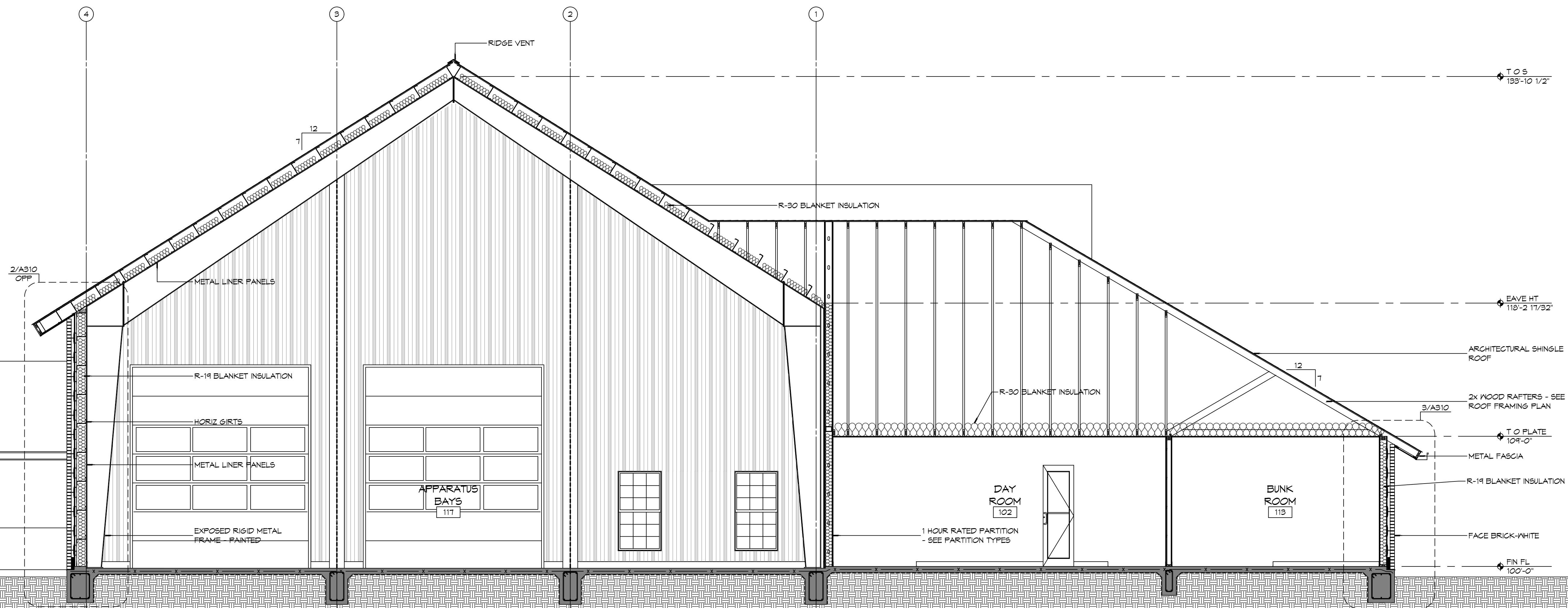

1 BUILDING SECTION
SCALE: 1/4" = 1'-0"

#	DESCRIPTION	DATE

SEAL:

NEW FIRE STATION #10
ST. TAMMANY FIRE PROTECTION
DISTRICT No. 1

2148 LAKESHORE VISTA BLVD
 SLIDELL, LA 70461
 JOB No: 2519 DATE: 12-05-2025
 DRAWN BY: CKD CHECKED BY: JME

SHEET TITLE:
 BUILDING SECTIONS

DRAWING NUMBER:
A301

SHEET No: 21 of 37

FILE NAME: A:\1 - General\13110 - 13 - 2019 - 410 (Architect) - Dammon\A302 - 13110.dwg, PLOT DATE: 8/26/2025, PLOT TIME: 10:45:00 AM, PLOT DEVICE: HP DesignJet T1300e, PLOT SCALE: 1/4" = 1'-0"

GENERAL SHEET NOTES

- COORDINATE ATTIC ACCESS PANEL LOCATION WITH MEZZANINE HVAC EQUIPMENT AND DUCTWORK.
- COORDINATE ATTIC ACCESS PANEL DIMENSIONS WITH LARGEST EQUIPMENT COMPONENT LOCATED IN ATTIC SPACE IT SERVES.

DAMMON ENGINEERING, INC.
 LOUISIANA & MISSISSIPPI
 Chief Engineer: Brian Mistich, PE
 554 Old Spanish Trail
 Slidell, LA 70458
 www.dammonengineering.com
 info@dammonengineering.com
 PH: 985.649.5832

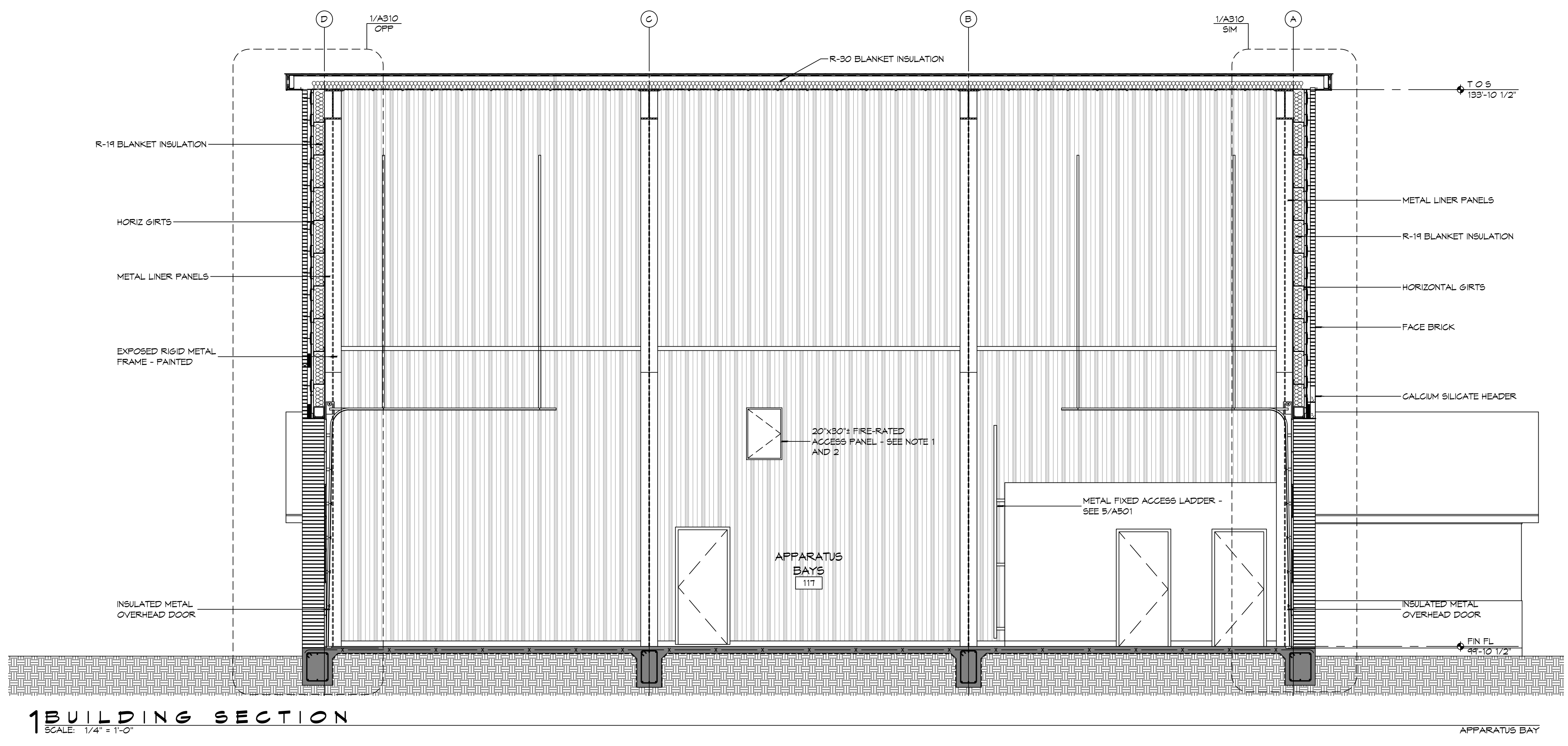
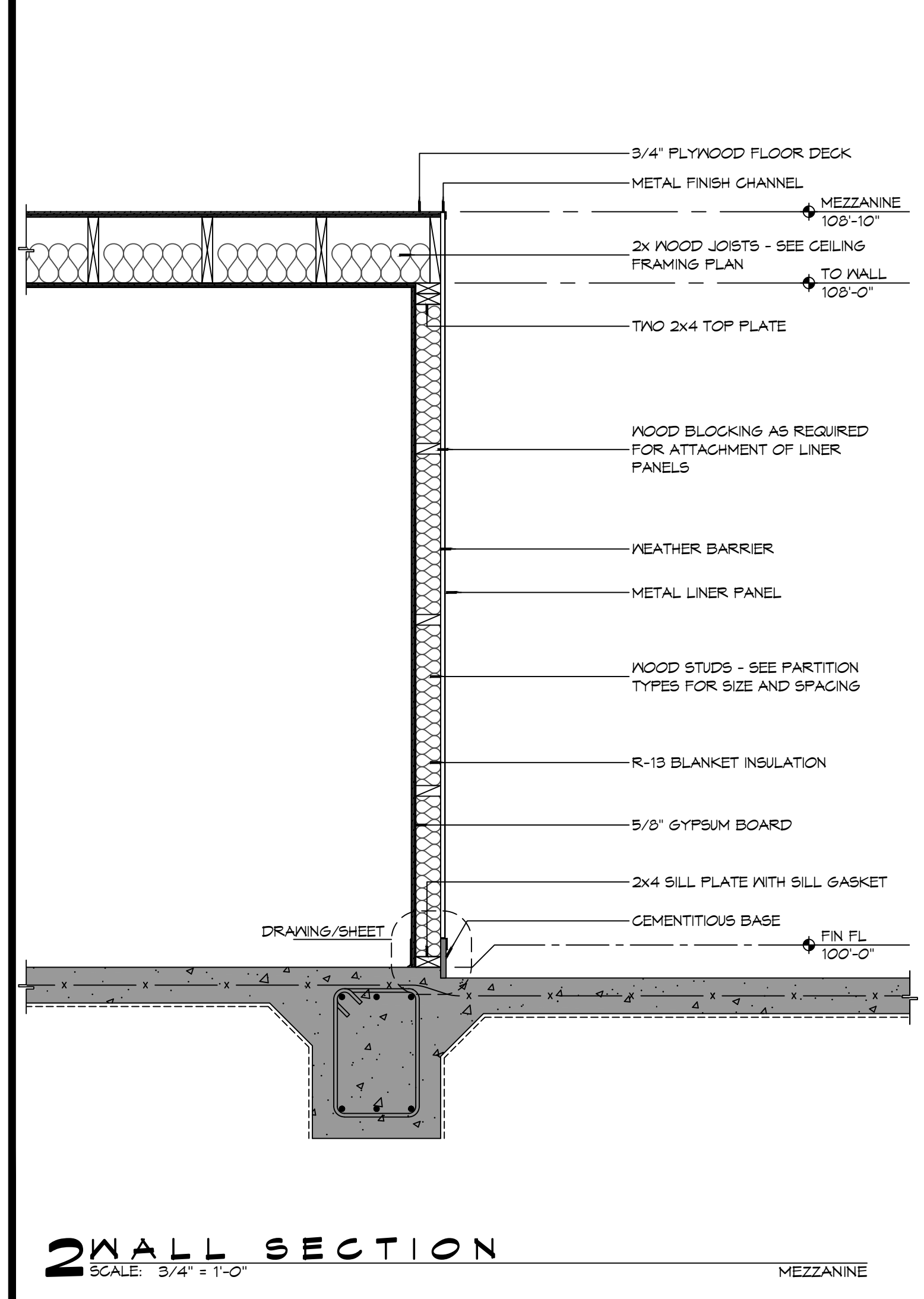
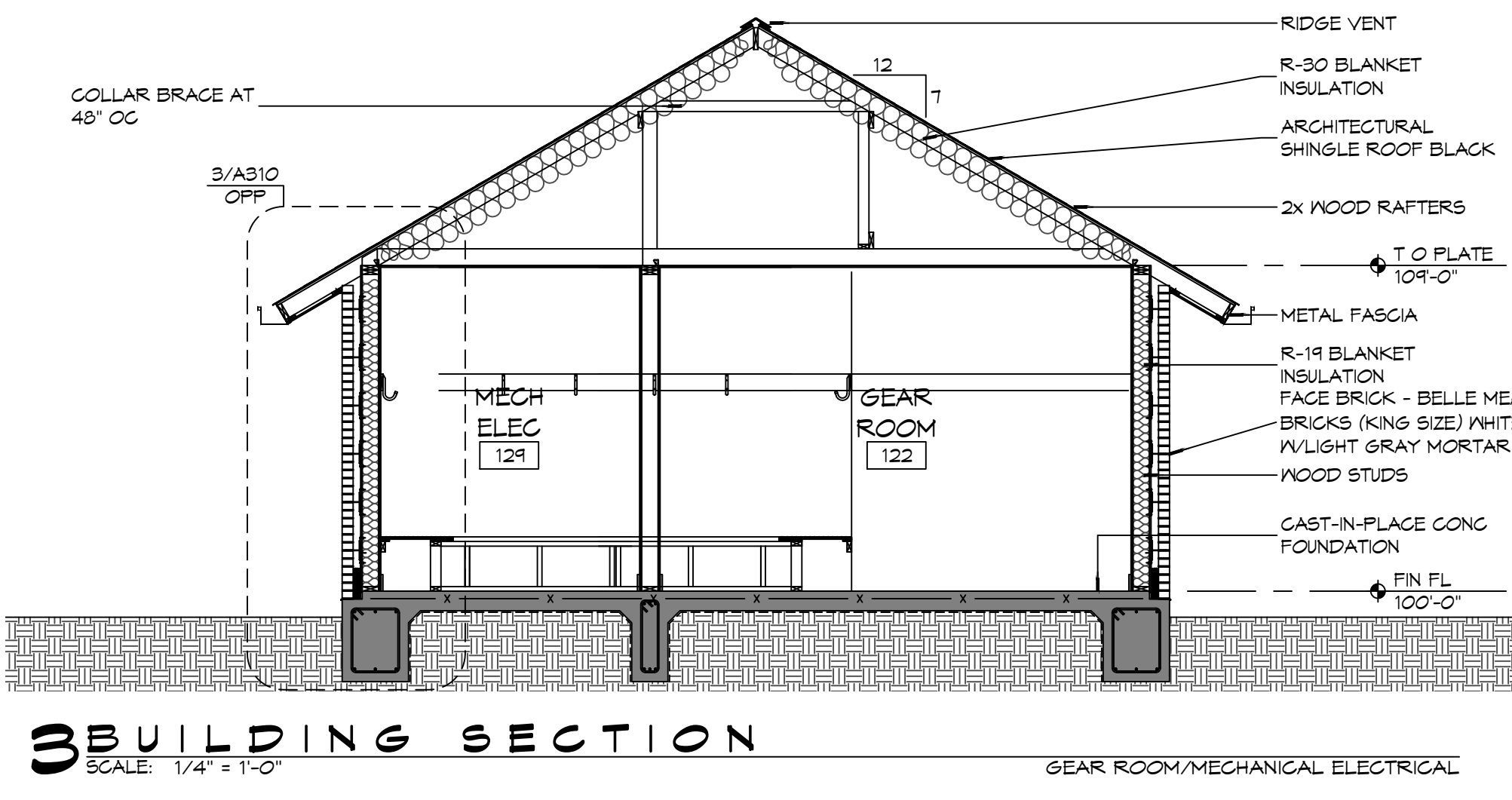
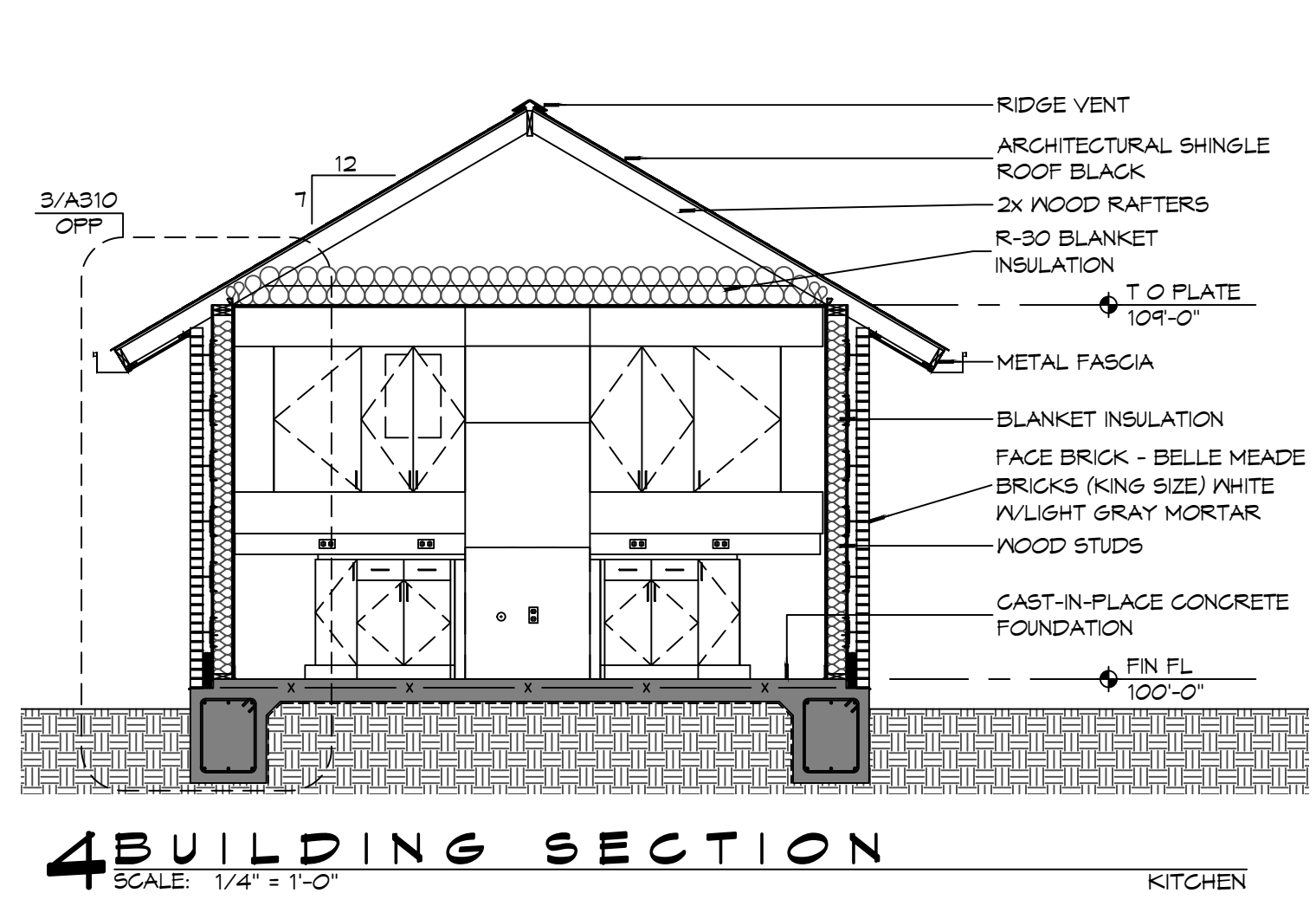

#	DESCRIPTION	DATE

SEAL:

NEW FIRE STATION #10
 ST. TAMMANY FIRE PROTECTION DISTRICT NO. 1
 2148 LAKESHORE VISTA BLVD
 SLIDELL, LA 70461
 JOB No: 2519 DATE: 12-05-2025
 DRAWN BY: CKD CHECKED BY: JMS

SHEET TITLE:
 BUILDING SECTIONS
 DRAWING NUMBER:
A302
 SHEET No: 22 of 31

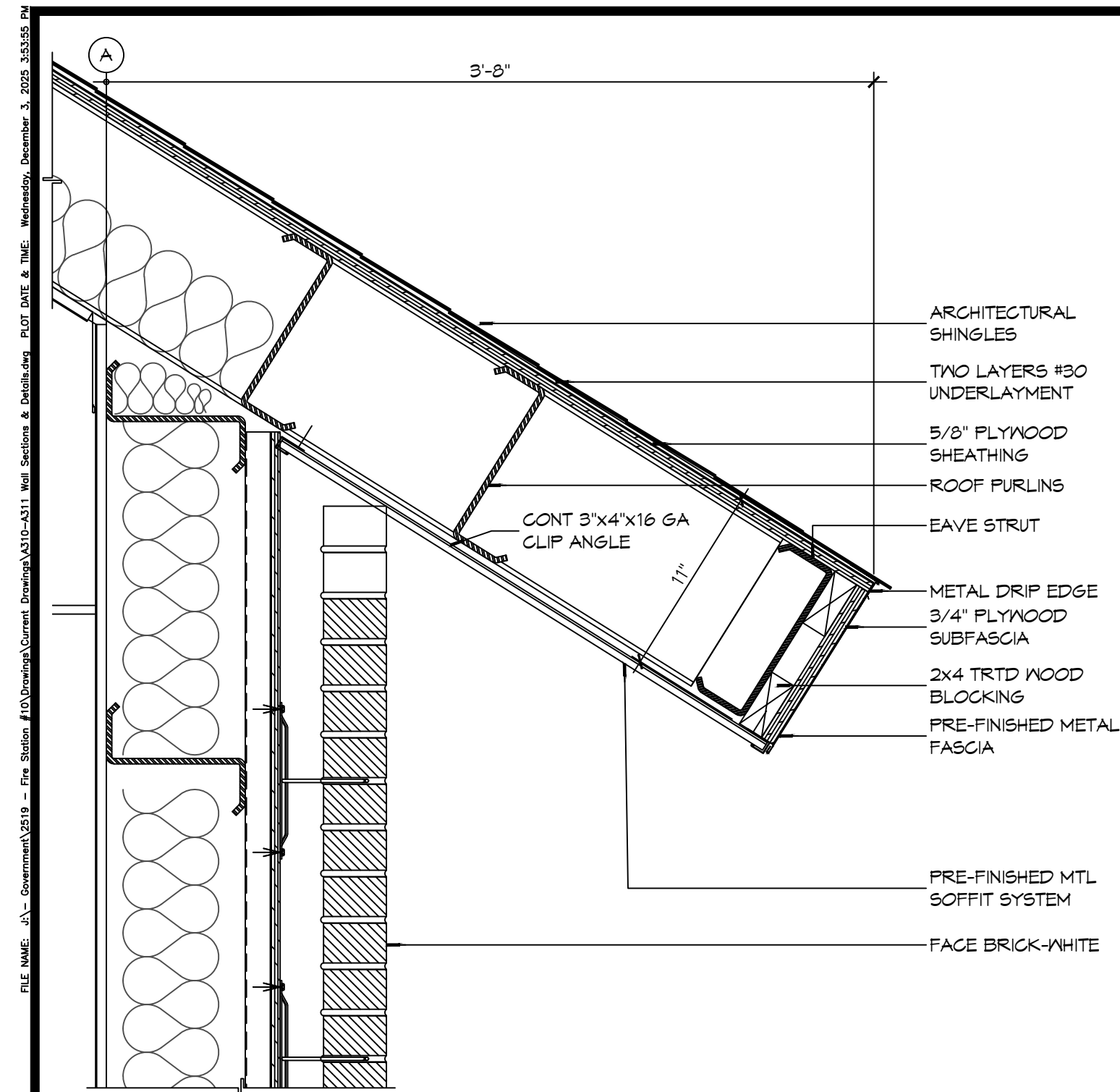

6 DETAIL
SCALE: 1 1/2" = 1'-0"

APPARATUS BAY EAVE

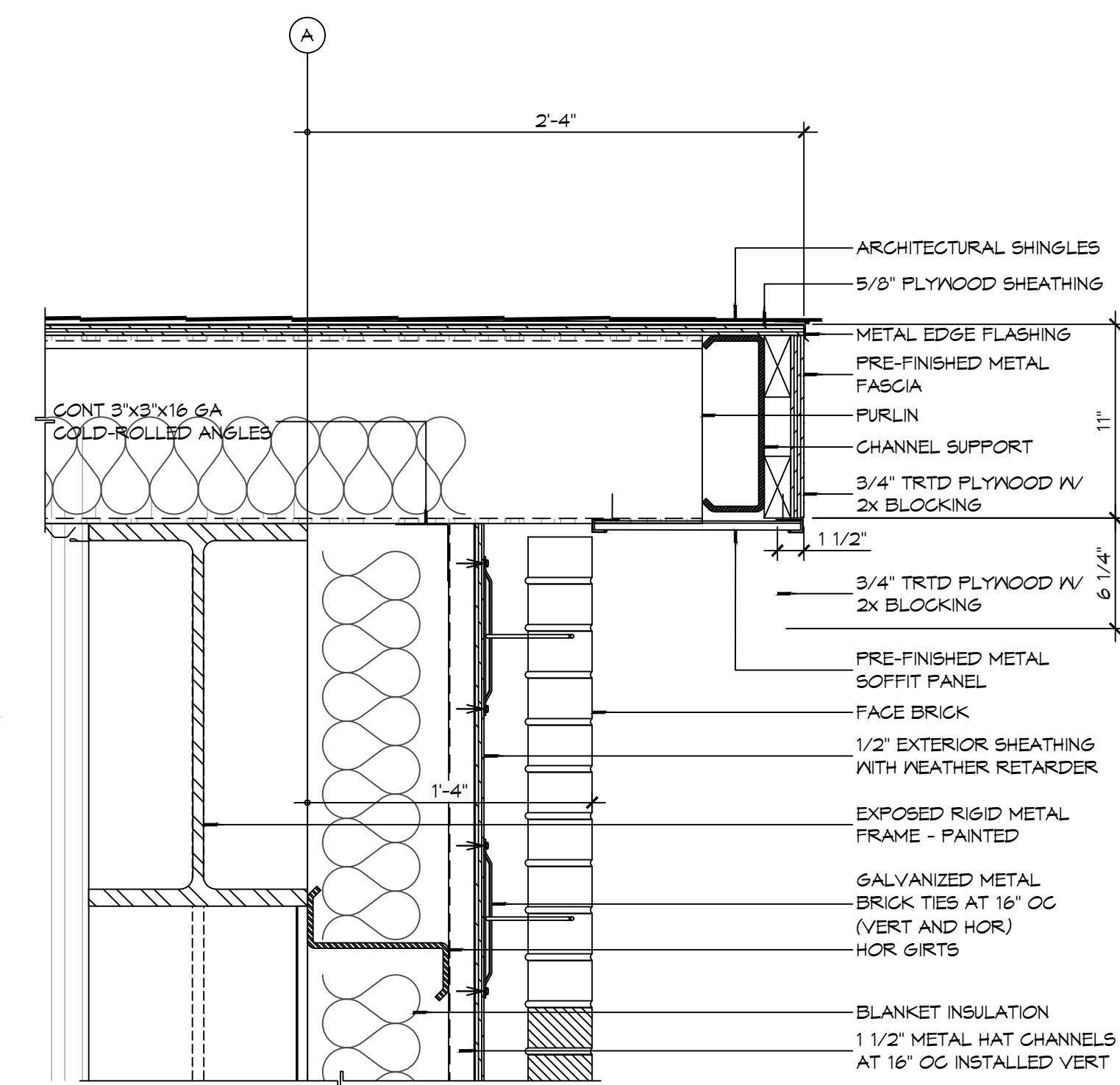

5 DETAIL
SCALE: 1 1/2" = 1'-0"

APPARATUS BAY ROOF RAKE

REFER TO BUILDING SECTIONS FOR
PLACEMENT OF ATTIC INSULATION AS
LOCATION MAY VARY.

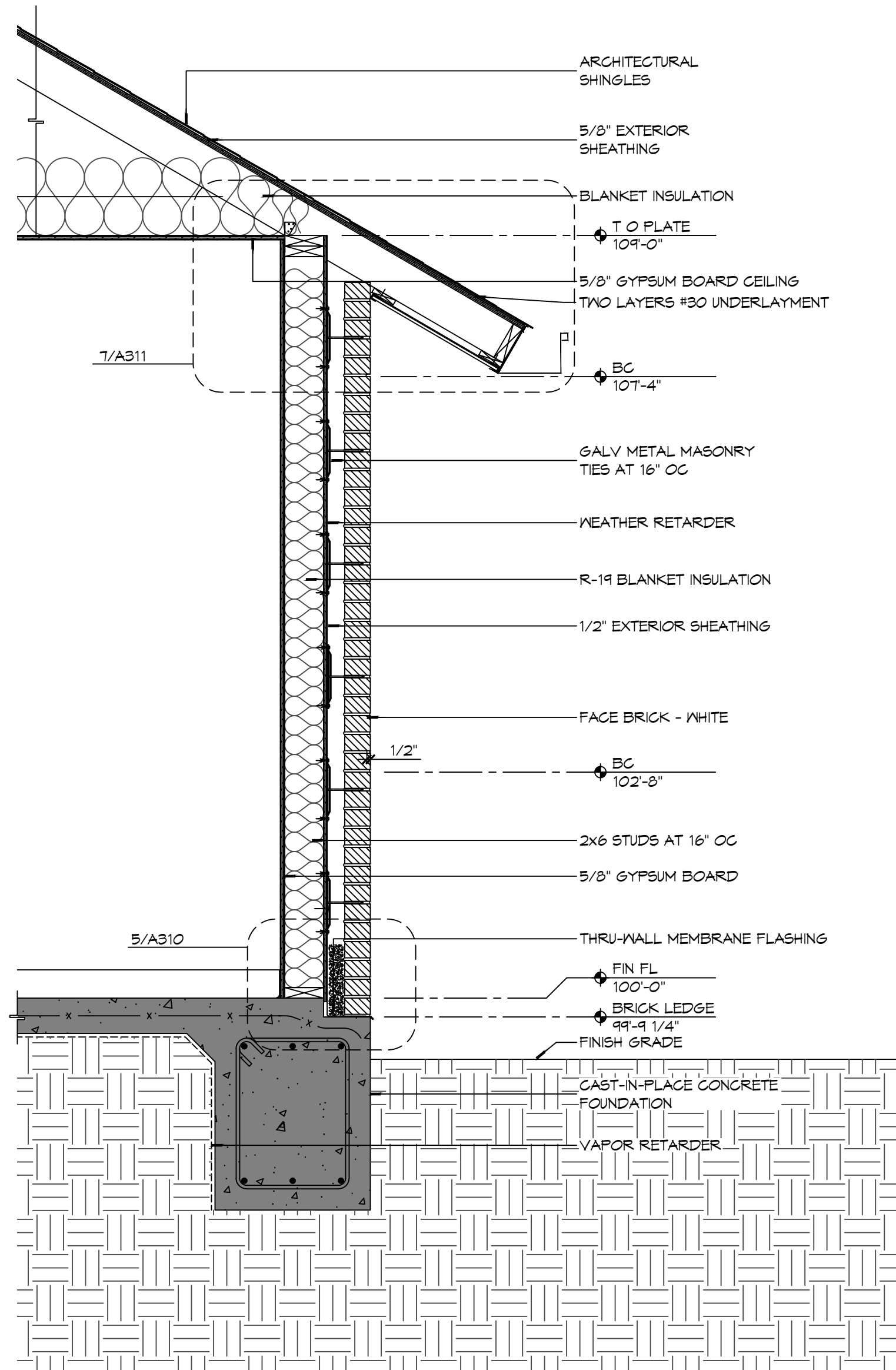

3 WALL SECTION
SCALE: 3/4" = 1'-0"

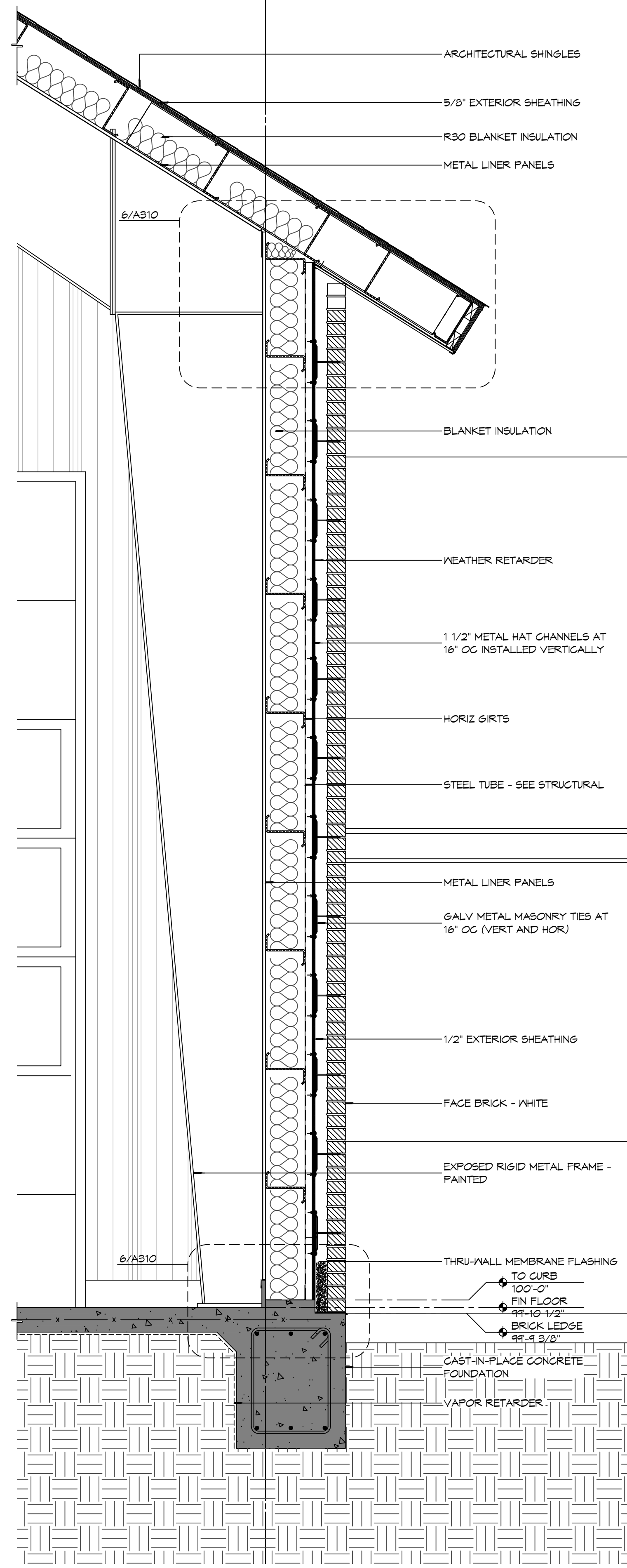

2 WALL SECTION
SCALE: 3/4" = 1'-0"

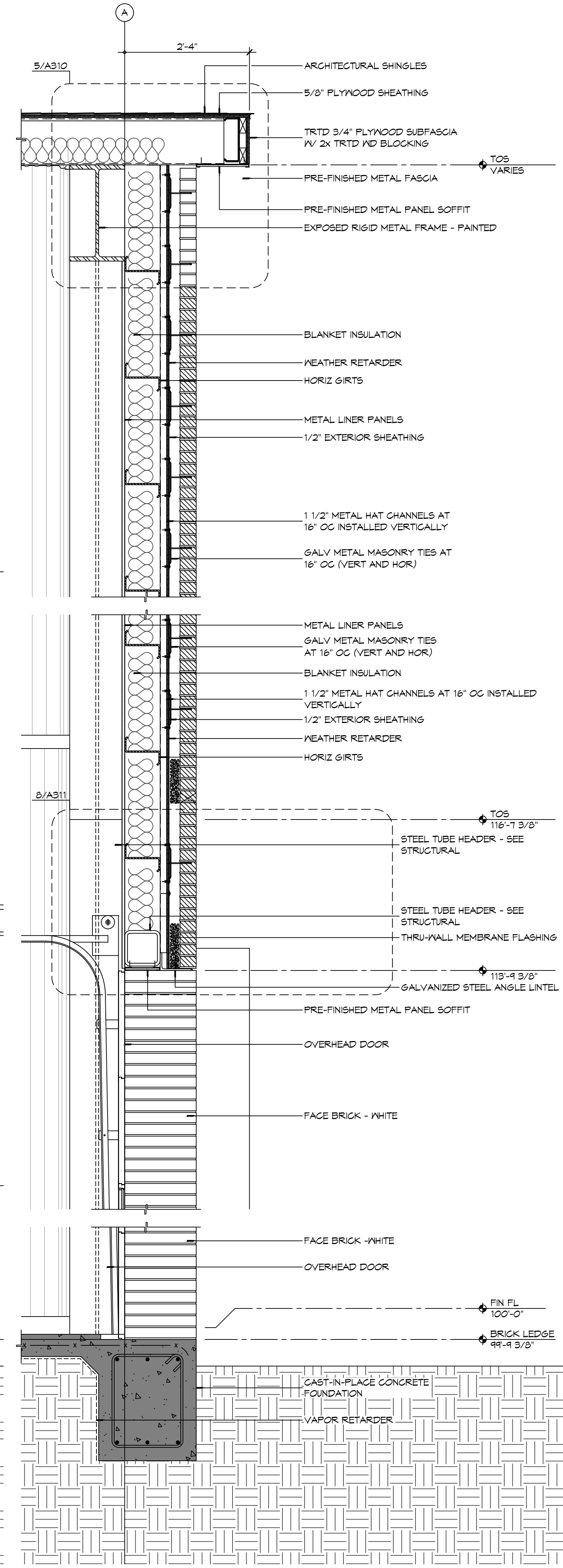

1 WALL SECTION
SCALE: 3/4" = 1'-0"

NOT USED

4 WALL SECTION
SCALE: 3/4" = 1'-0"

#	DESCRIPTION	DATE

SEAL:

NEW FIRE STATION #10
ST. TAMMANY FIRE PROTECTION
DISTRICT No. 1
248 LAKESHORE VISTA BLVD
SLIDELL, LA 70461
JOB No: 2519 DATE: 12-05-2025
DRAWN BY: CKD CHECKED BY: JMS

SHEET TITLE:
BUILDING SECTIONS
DRAWING NUMBER:
A310

FILE NAME: A:\Projects\2019 - Fire Station 2019\2019 Fire Station\2019 Fire Station.dwg, PLOT DATE: 12/13/2019, 12:13:03 PM, PLOT BY: JMS

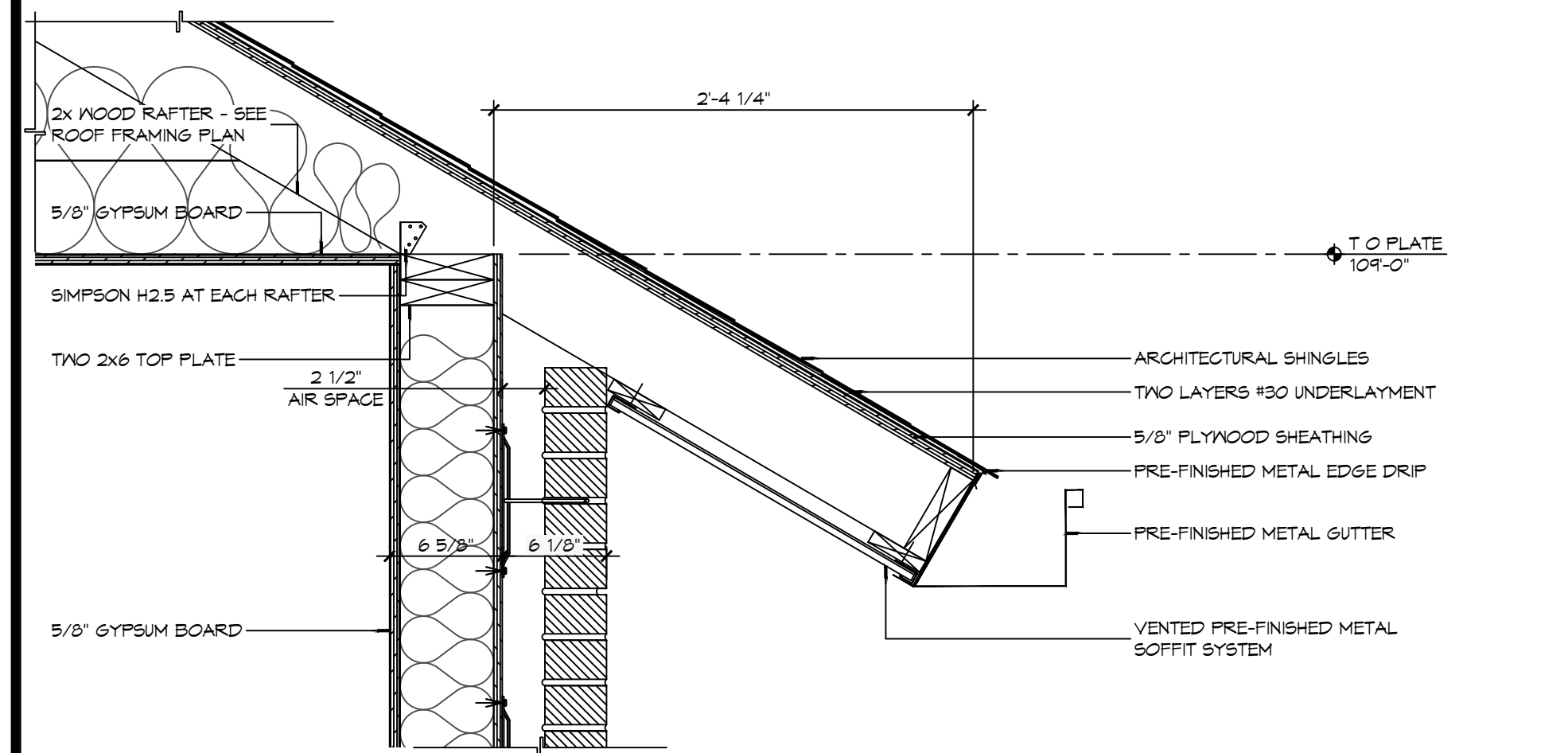

7 DETAIL
SCALE: 1/4" = 1'-0"
TYPICAL EAVE OVERHANG

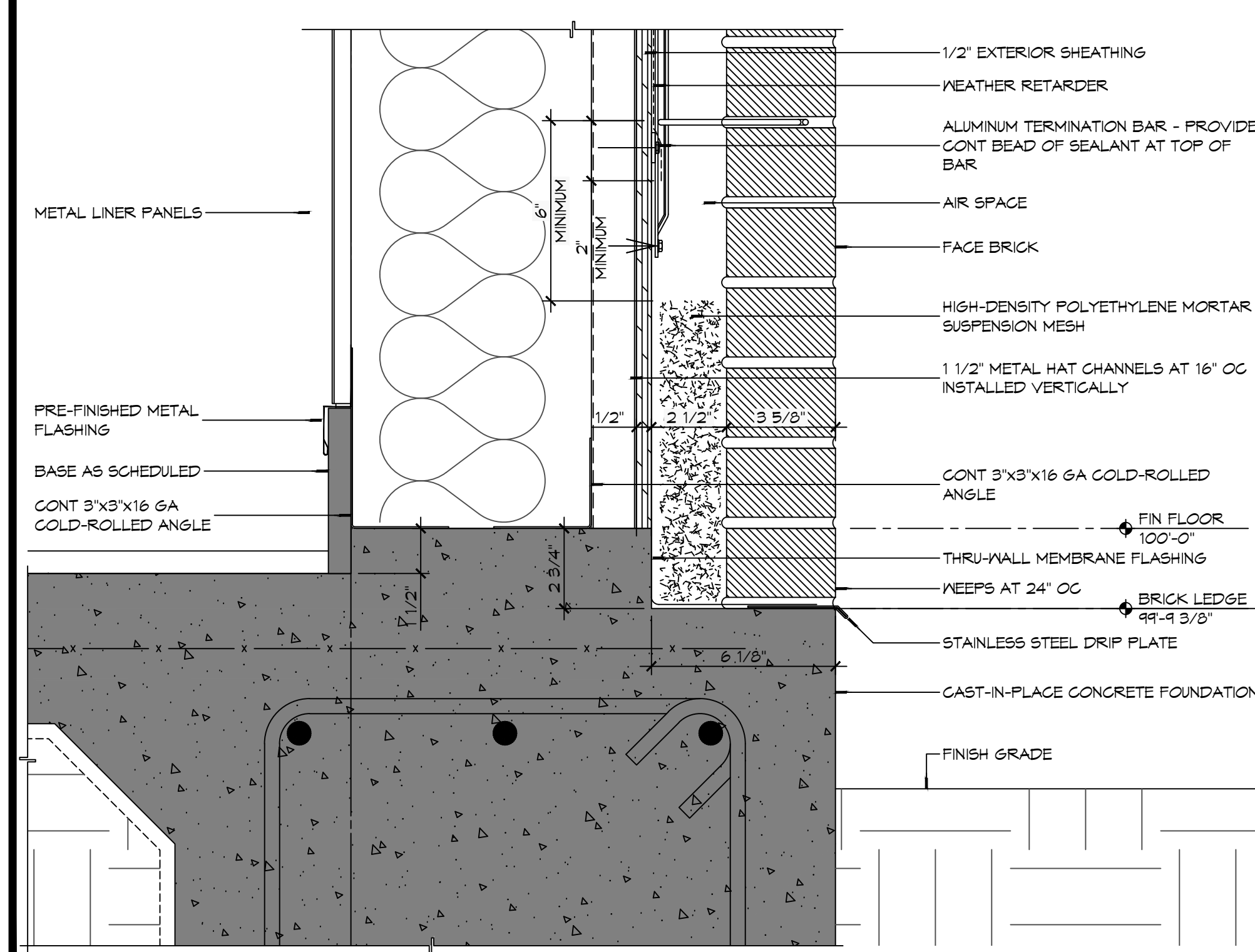

6 DETAIL
SCALE: 3/4" = 1'-0"
TYPICAL MASONRY BASE FLASHING AT METAL BUILDING

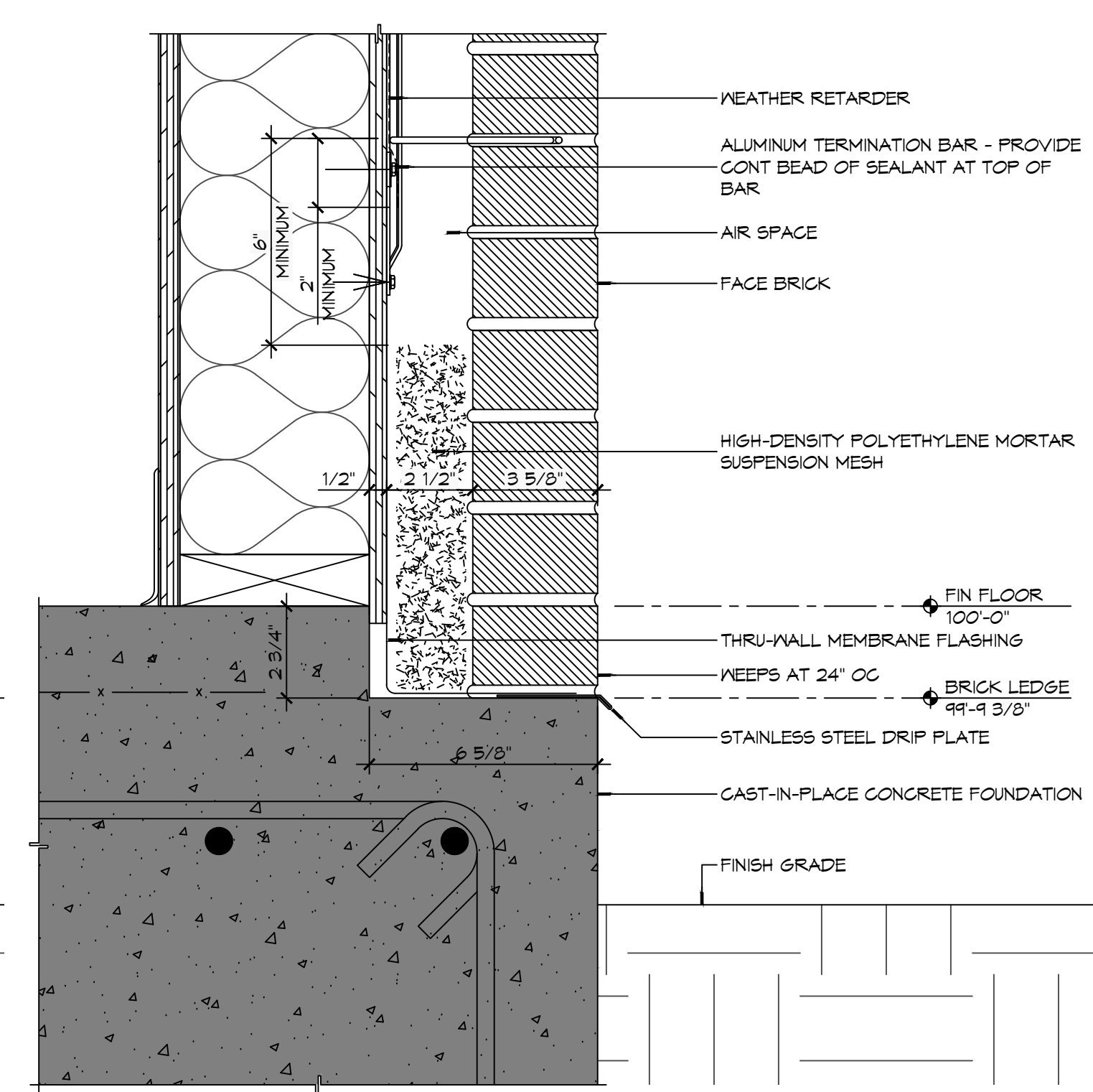

5 DETAIL
SCALE: 3/4" = 1'-0"
TYPICAL MASONRY BASE FLASHING

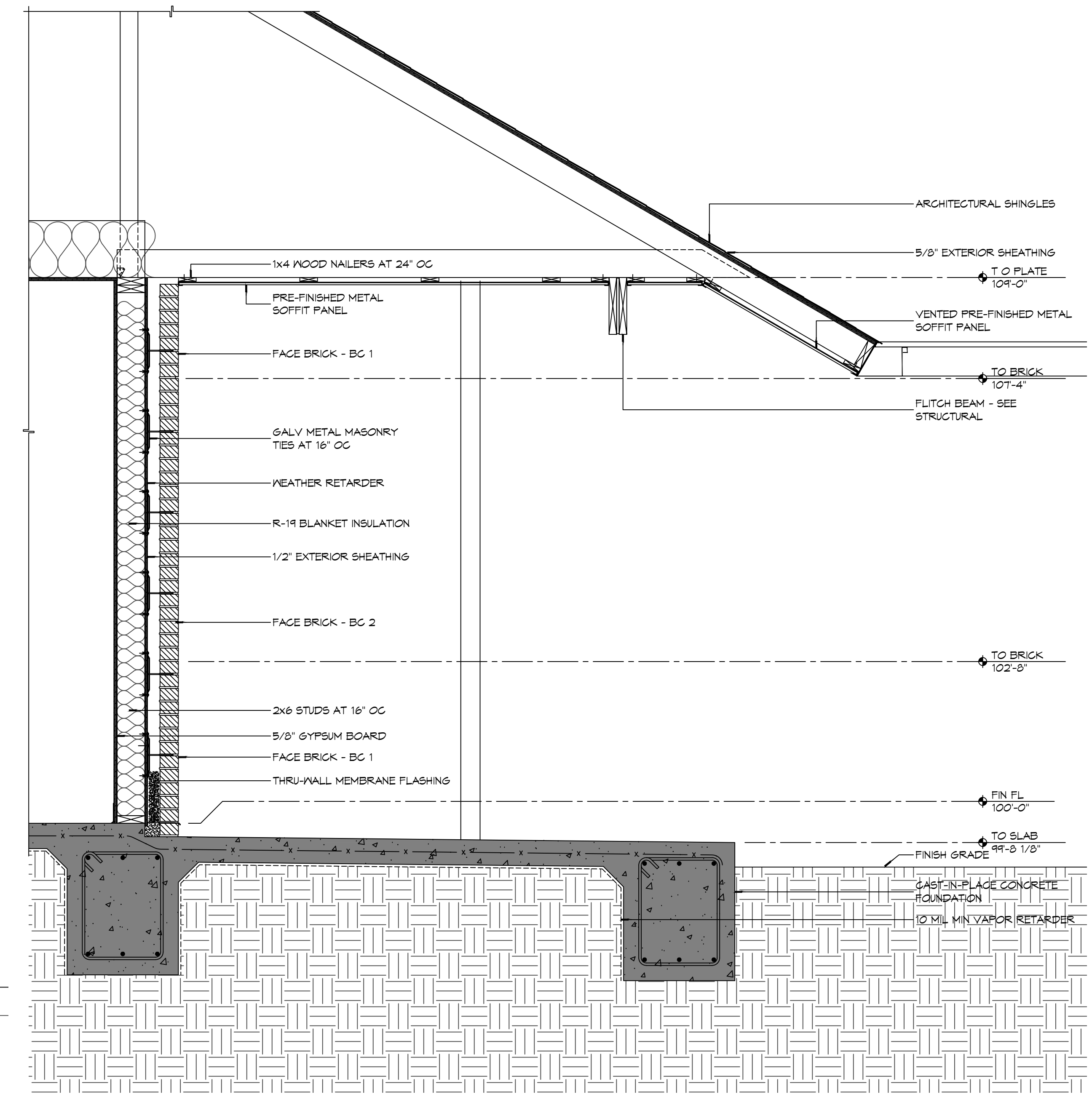

1 WALL SECTION
SCALE: 3/4" = 1'-0"

#	DESCRIPTION	DATE

SEAL:

NEW FIRE STATION #10
ST. TAMMANY FIRE PROTECTION DISTRICT NO. 1
 2148 LAKESHORE VISTA BLVD
 SLIDELL, LA 70461
 JOB No: 2519 DATE: 12-09-2025
 DRAWN BY: CKD CHECKED BY: JMS

SHEET TITLE:
 WALL SECTIONS AND
 DETAILS

DRAWING NUMBER:

A311

FILE NAME: A:_Drawing\2019 - The Shores At Dammon\Interior Elevations.dwg, PLOT DATE: 12/11/2019, 12:13:12, Plotter: HP DesignJet 5000, Plotter Driver: HP DesignJet 5000, Plotter Location: C:\Program Files\HP\DesignJet\bin\hpplmutil.dll

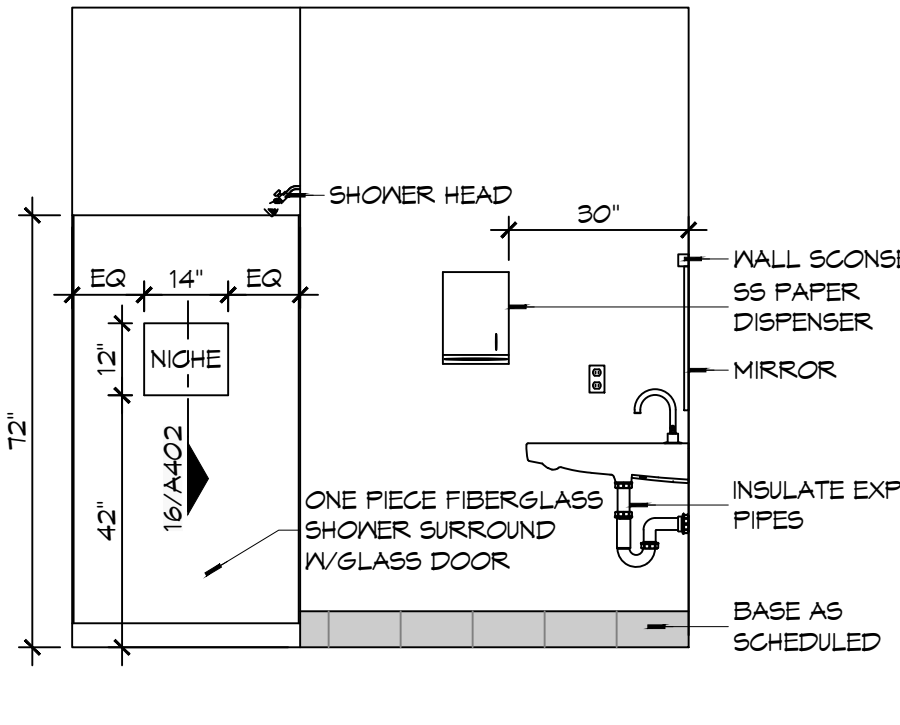

15 INTERIOR ELEV SCALE: 3/8" = 1'-0" WOMENS TOILET - 104

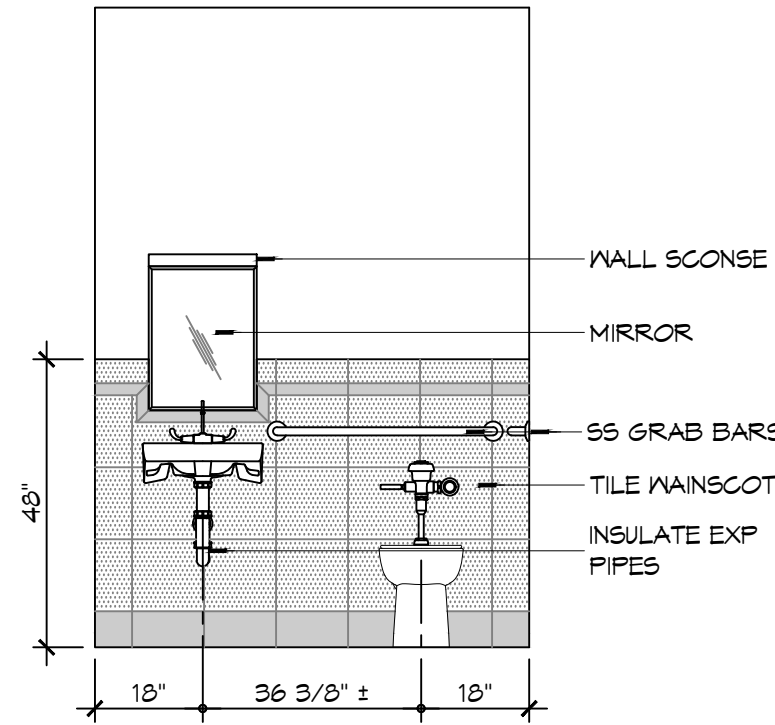

14 INTERIOR ELEV SCALE: 3/8" = 1'-0" WOMENS TOILET - 104

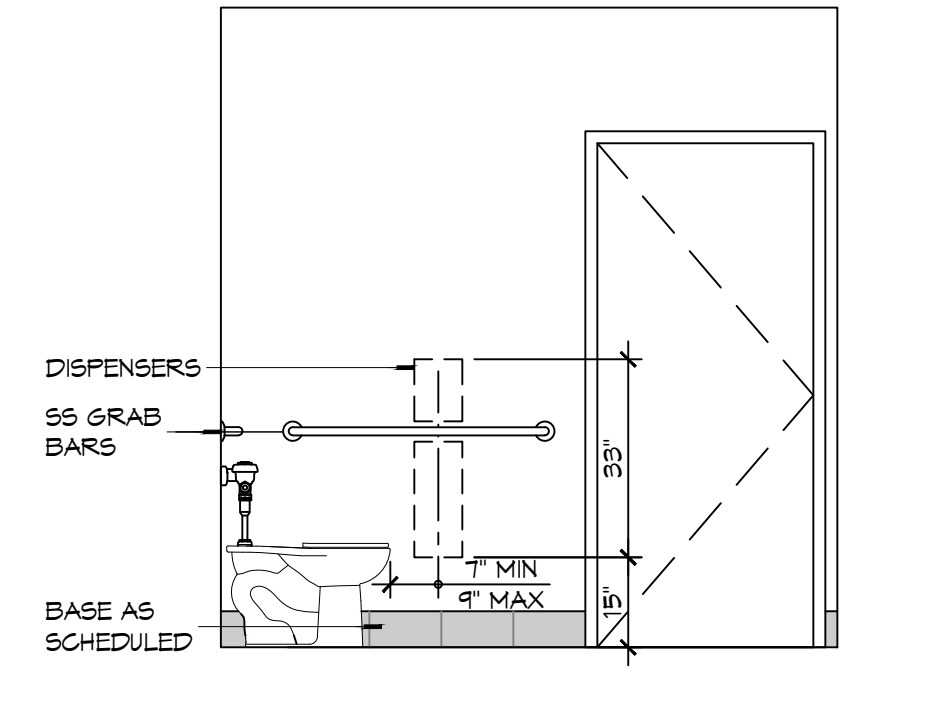

13 INTERIOR ELEV SCALE: 3/8" = 1'-0" WOMENS TOILET - 104

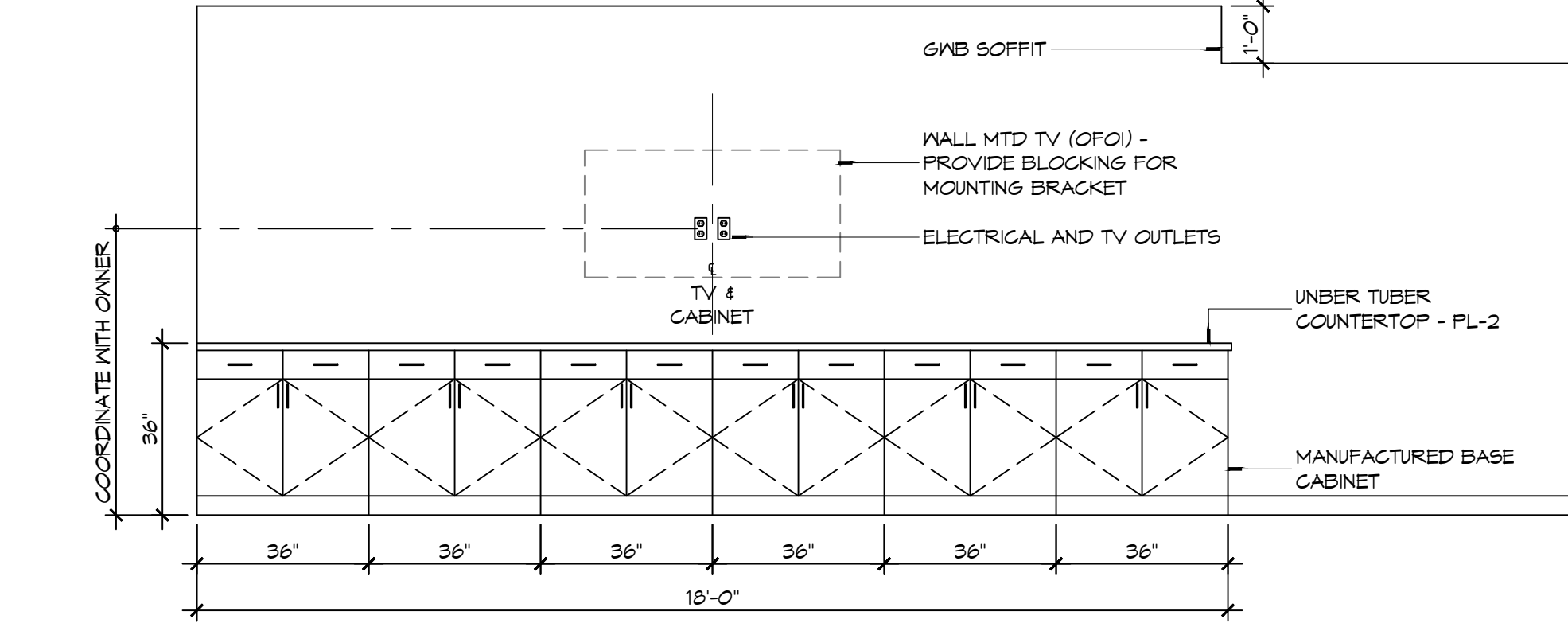

12 INTERIOR ELEVATION SCALE: 3/8" = 1'-0" DAY ROOM - 102

- ### INTERIOR NOTES
- REFER TO SHEET 0003 FOR TYPICAL MOUNTING HEIGHTS AND FLOOR CLEARANCE REQUIREMENTS WHERE NOT SHOWN ON THIS SHEET.
 - NOT USED
 - PROVIDE 1/8" R EASED EDGES AT ALL EXPOSED GRANITE COUNTERTOP AND BACKSLASH EDGES UNLESS OTHERWISE NOTED.
 - BLOCKING FOR CABINETS IS NOT SHOWN ON THESE DRAWINGS. THE GENERAL CONTRACTOR SHALL BE RESPONSIBLE FOR PROVIDING AND COORDINATING WALL BLOCKING FOR CABINETRY. WHERE WOOD BLOCKING IS PROHIBITED BY CODE PROVIDE GALVANIZED SHEET BLOCKING.
 - PROVIDE 5/8" CEMENTITIOUS BACKERBOARD BEHIND ALL CERAMIC WALL TILE INSTALLATIONS. WHERE CERAMIC WALL TILE IS APPLIED TO A RATED WALL ASSEMBLY USE TYPE "X" MOISTURE RESISTANT G/M.
 - PROVIDE FULL FINISHED END PANELS ON ALL EXPOSED CASEWORK.
 - PROVIDE FILLER PANEL WHERE CASEWORK MEETS WALL. SCRIBE AS NECESSARY TO ACHIEVE TIGHT FIT TO FINISH SURFACE.
 - FIELD VERIFY (VIF) ALL DIMENSIONS PRIOR TO SHOP DRAWING SUBMITTAL.
 - ELEC OUTLETS INSTALLED AT GRANITE BACK SPLASHES SHALL BE MOUNTED IN A HORIZONTAL ORIENTATION WITH SATIN STAINLESS STEEL PLATE.
 - CLEARANCE REDUCTION SYSTEM SHALL COMPLY WITH NFPA 96.4.2.3.
 - SEE SHEET M102 FOR EXHAUST HOOD INSTALLATION DETAILS.
 - SINKS SHOWN ON THESE DRAWINGS INDICATE LOCATIONS ONLY AND NOT ACTUAL SIZES. THE CONTRACTOR SHALL BE RESPONSIBLE FOR COORDINATING ACTUAL SIZES AND TYPES WITH CABINET FABRICATOR PRIOR TO FABRICATION.

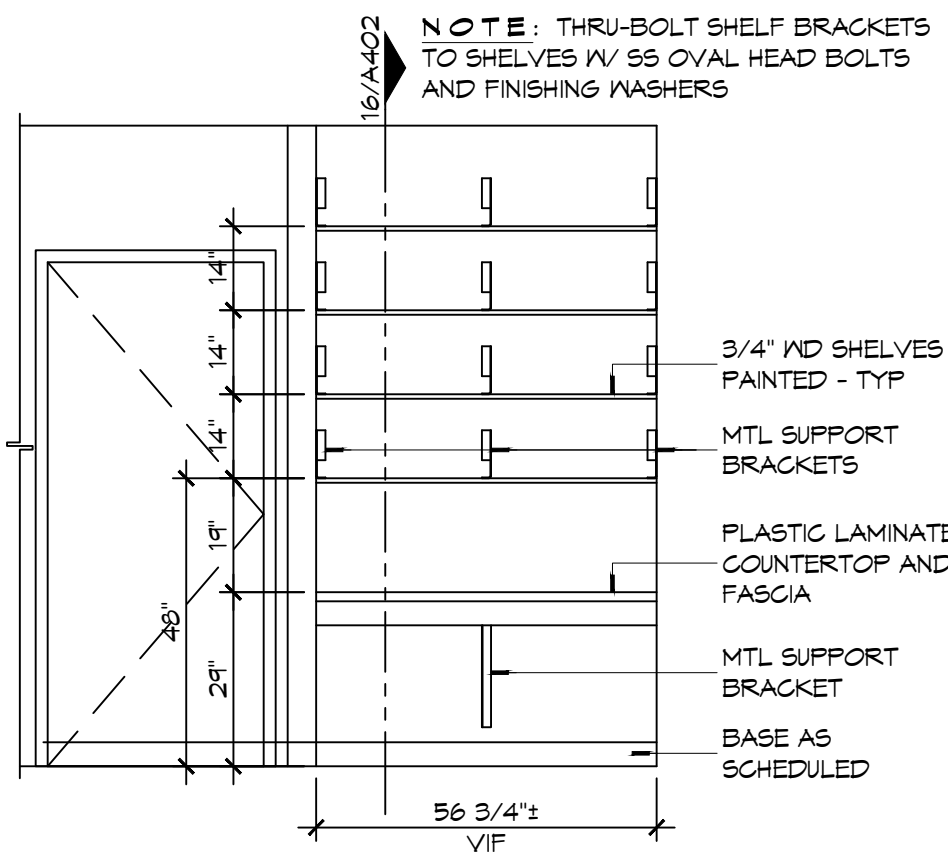

11 INTERIOR ELEV SCALE: 3/8" = 1'-0" BUNK ROOM - 113

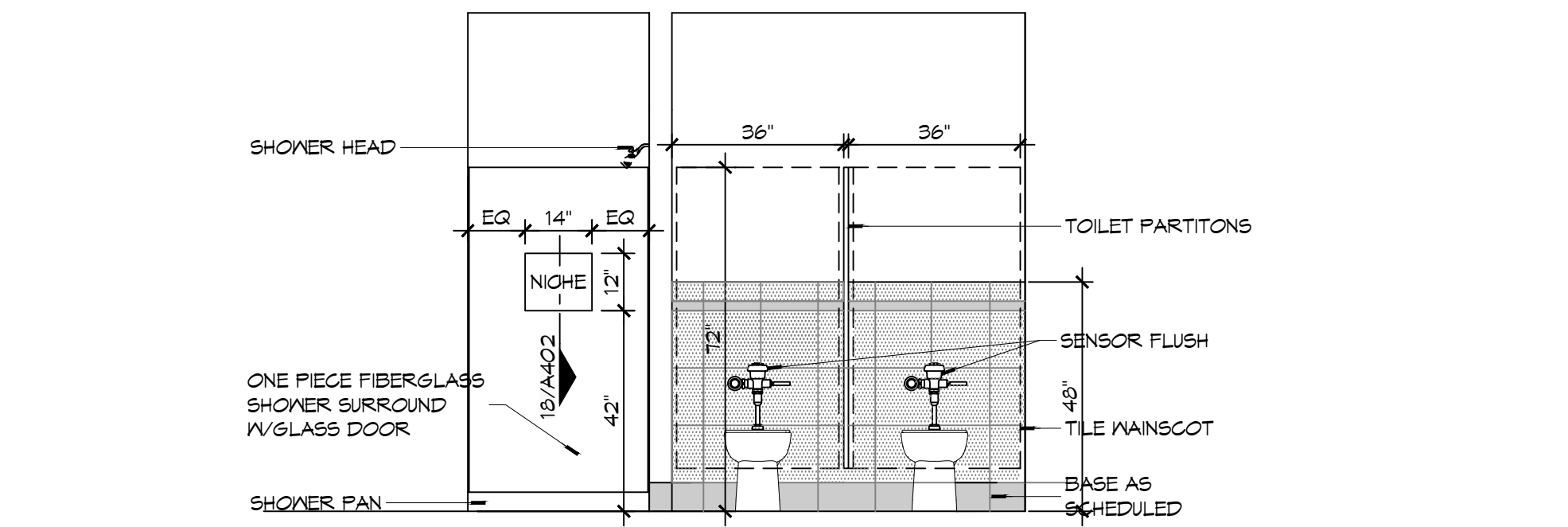

10 INTERIOR ELEVATION SCALE: 3/8" = 1'-0" MENS TOILET - 114 & MENS SHOWER - 116

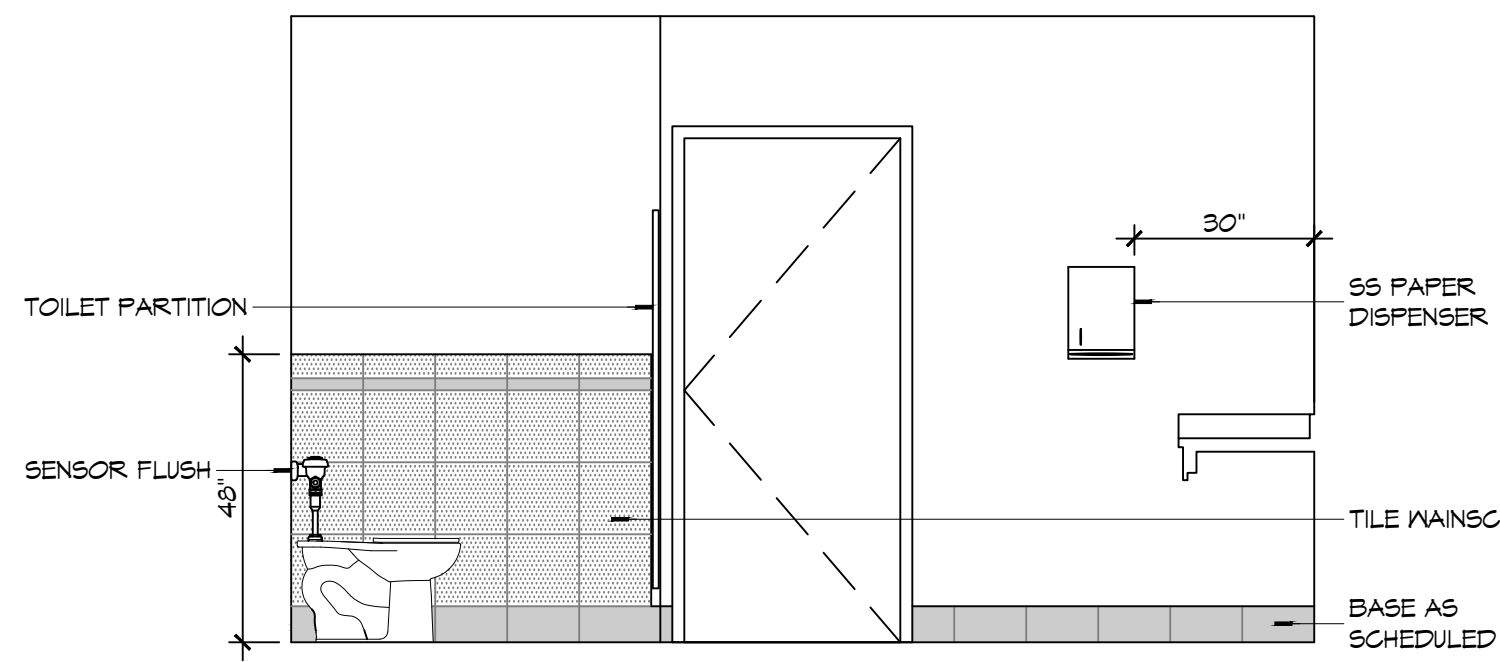

9 INTERIOR ELEVATION SCALE: 3/8" = 1'-0" MENS TOILET - 114

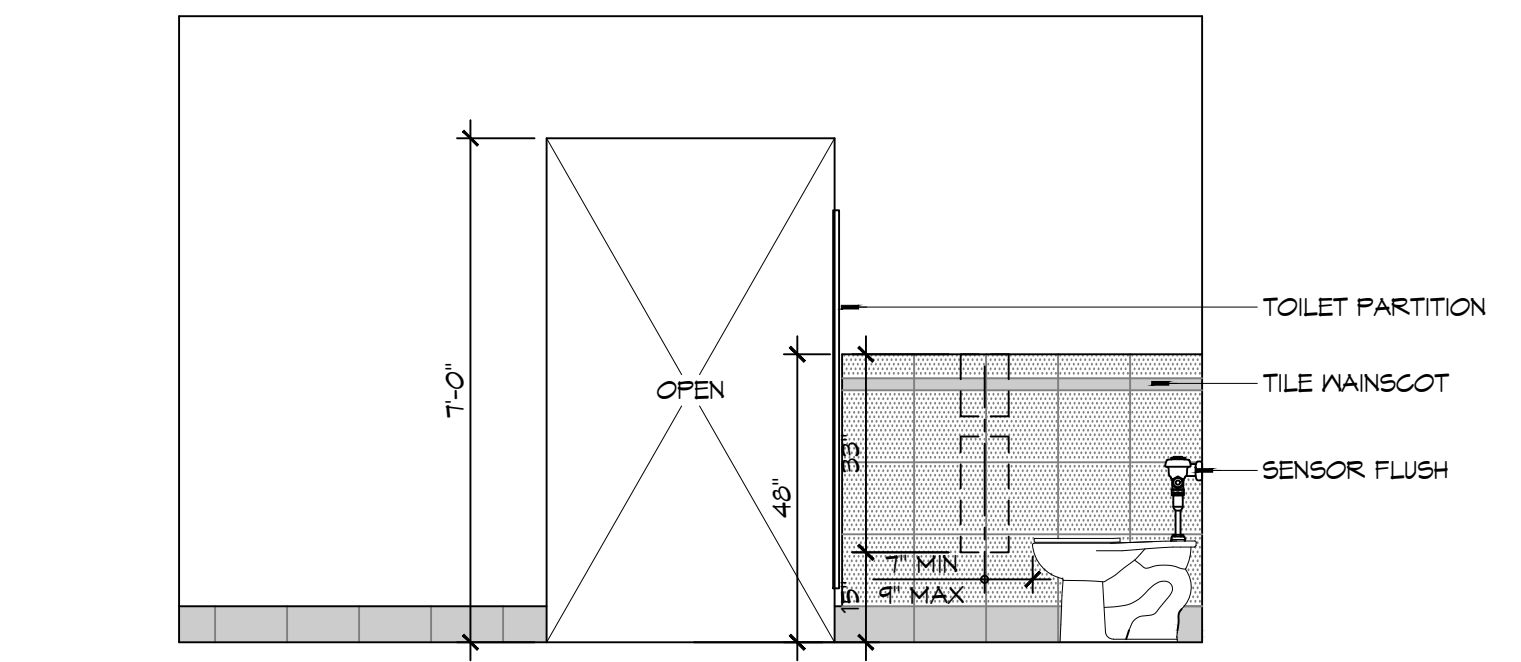

8 INTERIOR ELEVATION SCALE: 3/8" = 1'-0" MENS TOILET - 114

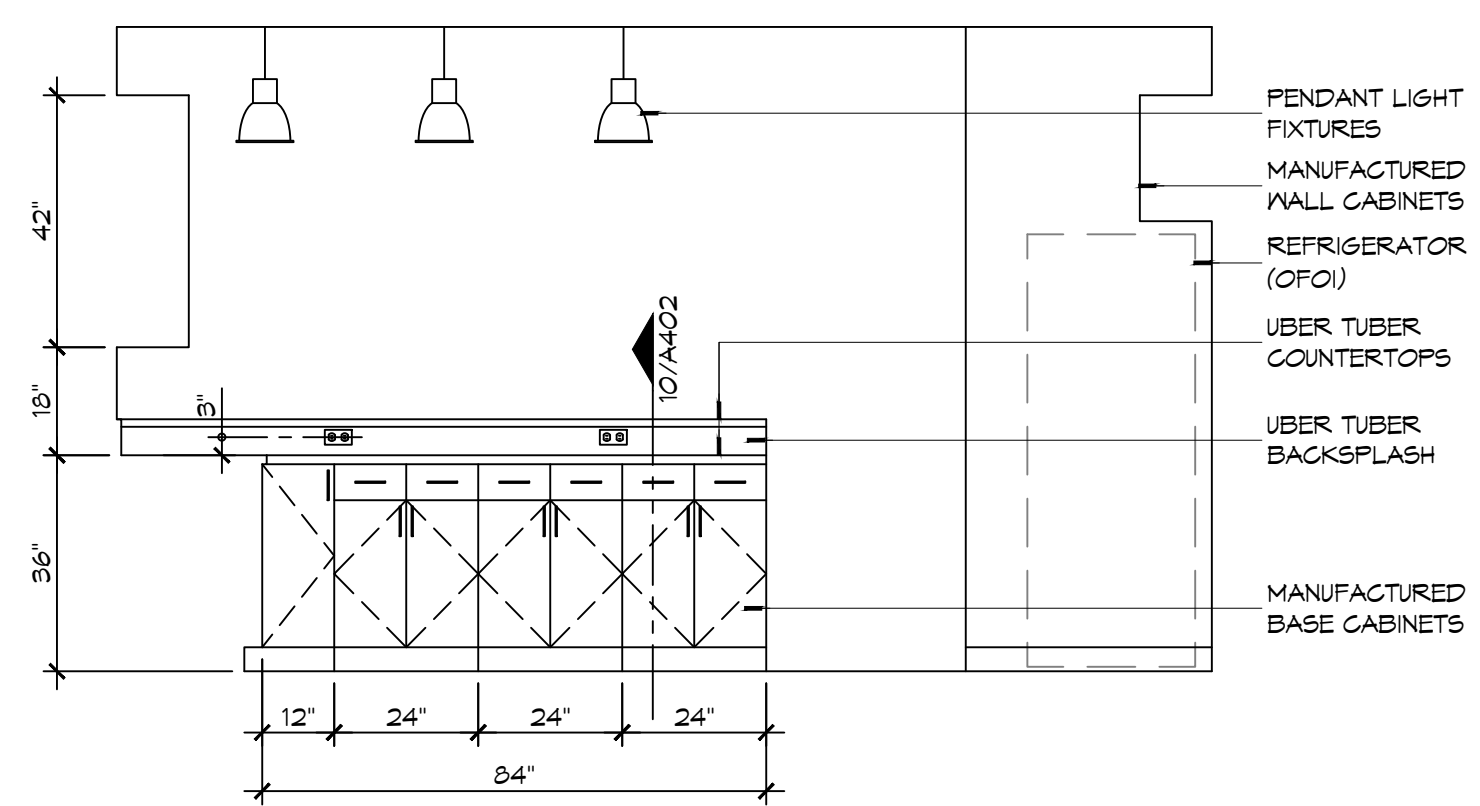

7 INTERIOR ELEVATION SCALE: 3/8" = 1'-0" KITCHEN - 103

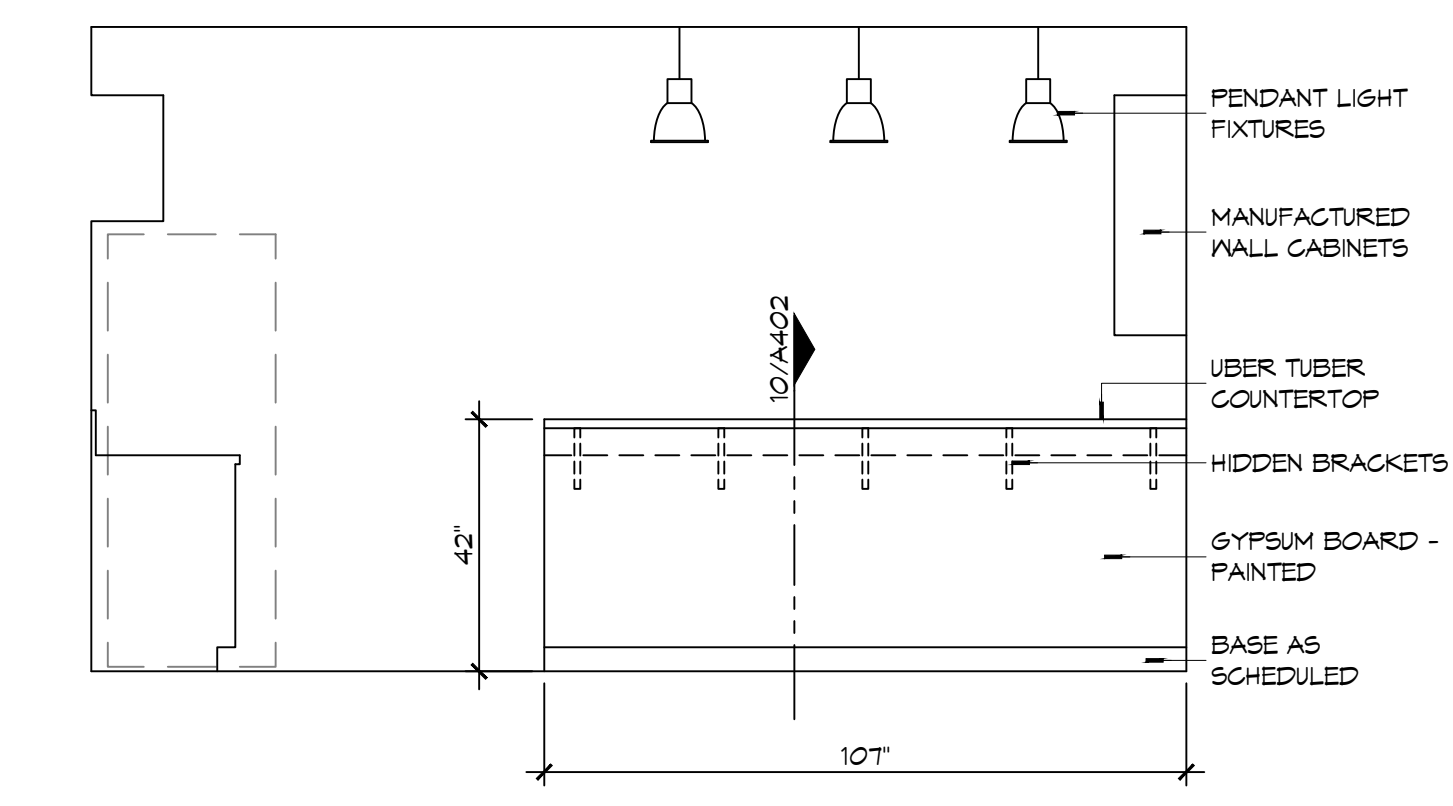

6 INTERIOR ELEVATION SCALE: 3/8" = 1'-0" KITCHEN - 103

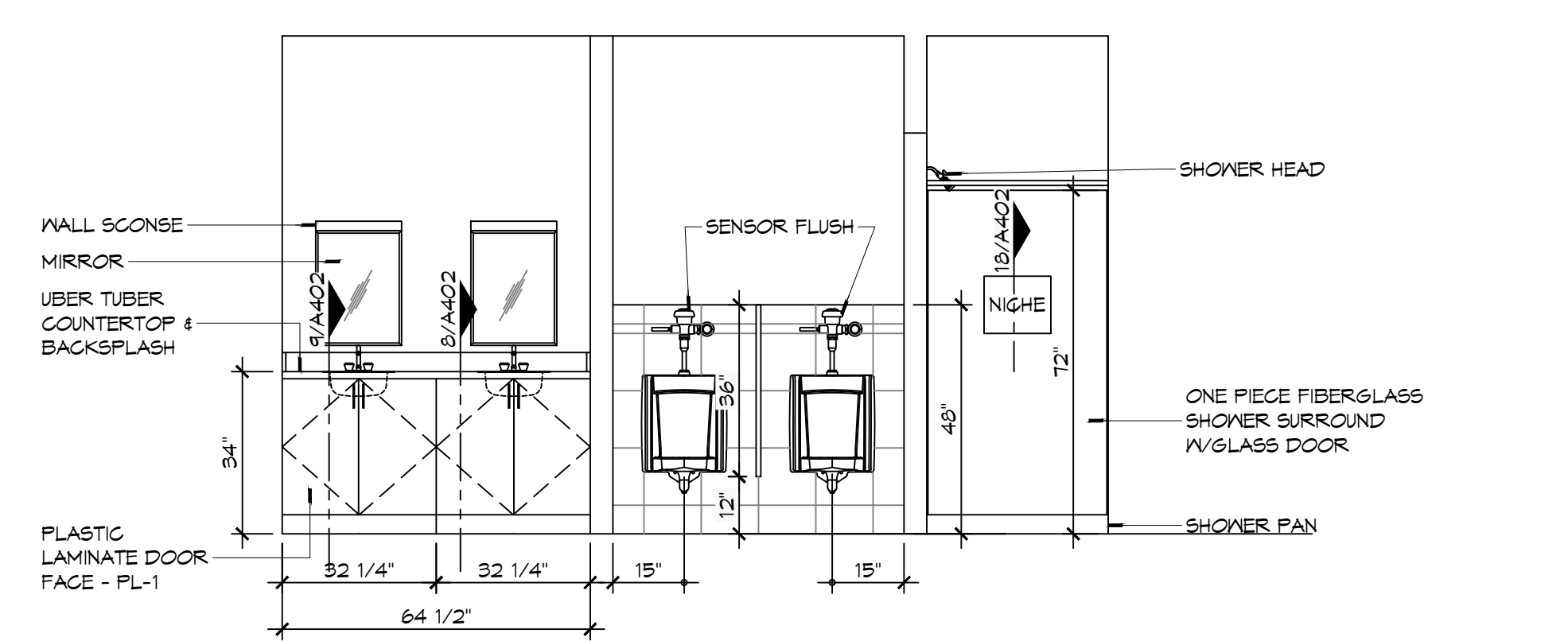

5 INTERIOR ELEVATION SCALE: 3/8" = 1'-0" MENS TOILET - 114 & MENS SHOWER - 116

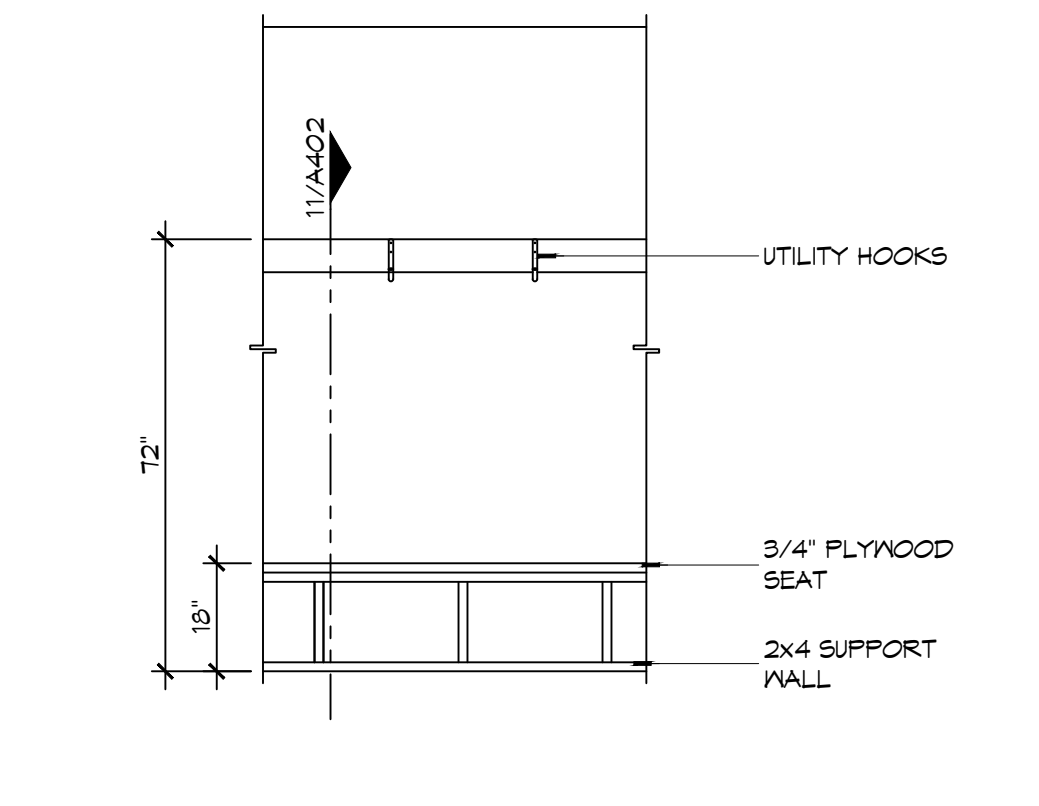

4 INTERIOR ELEV SCALE: 3/8" = 1'-0" GEAR ROOM - 122

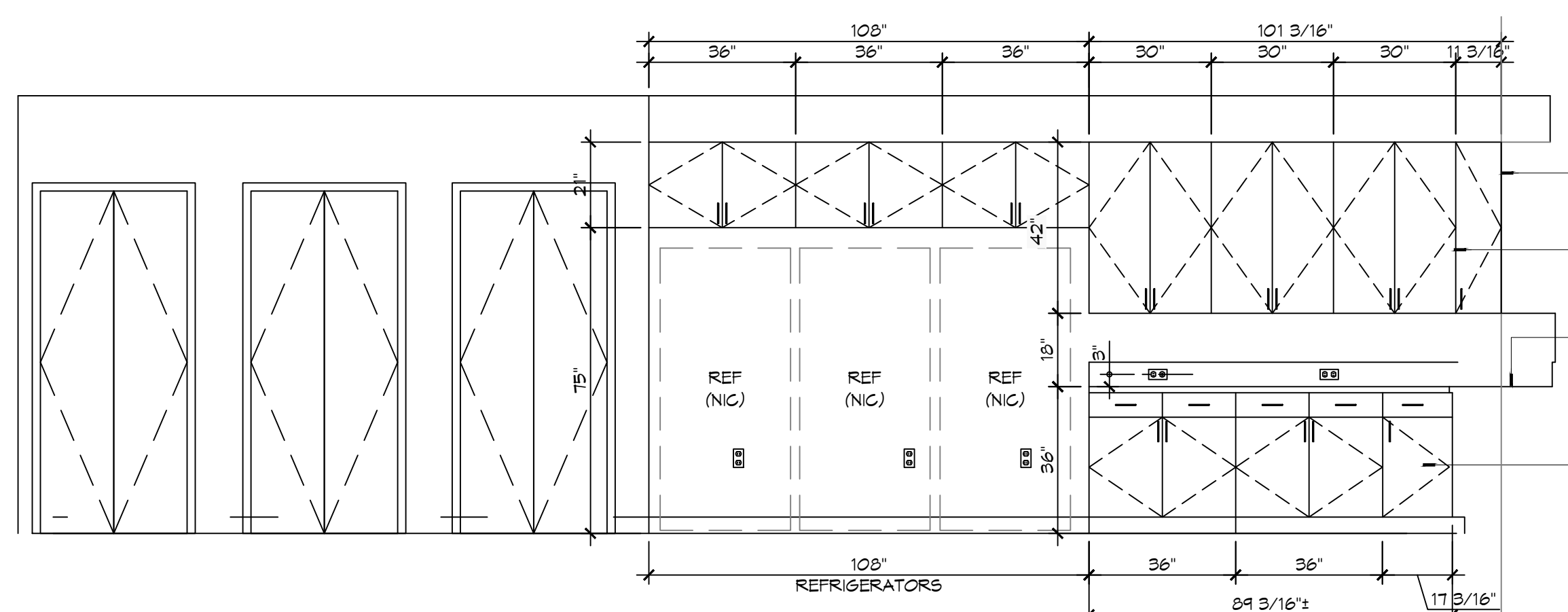

3 INTERIOR ELEVATION SCALE: 3/8" = 1'-0" KITCHEN - 103

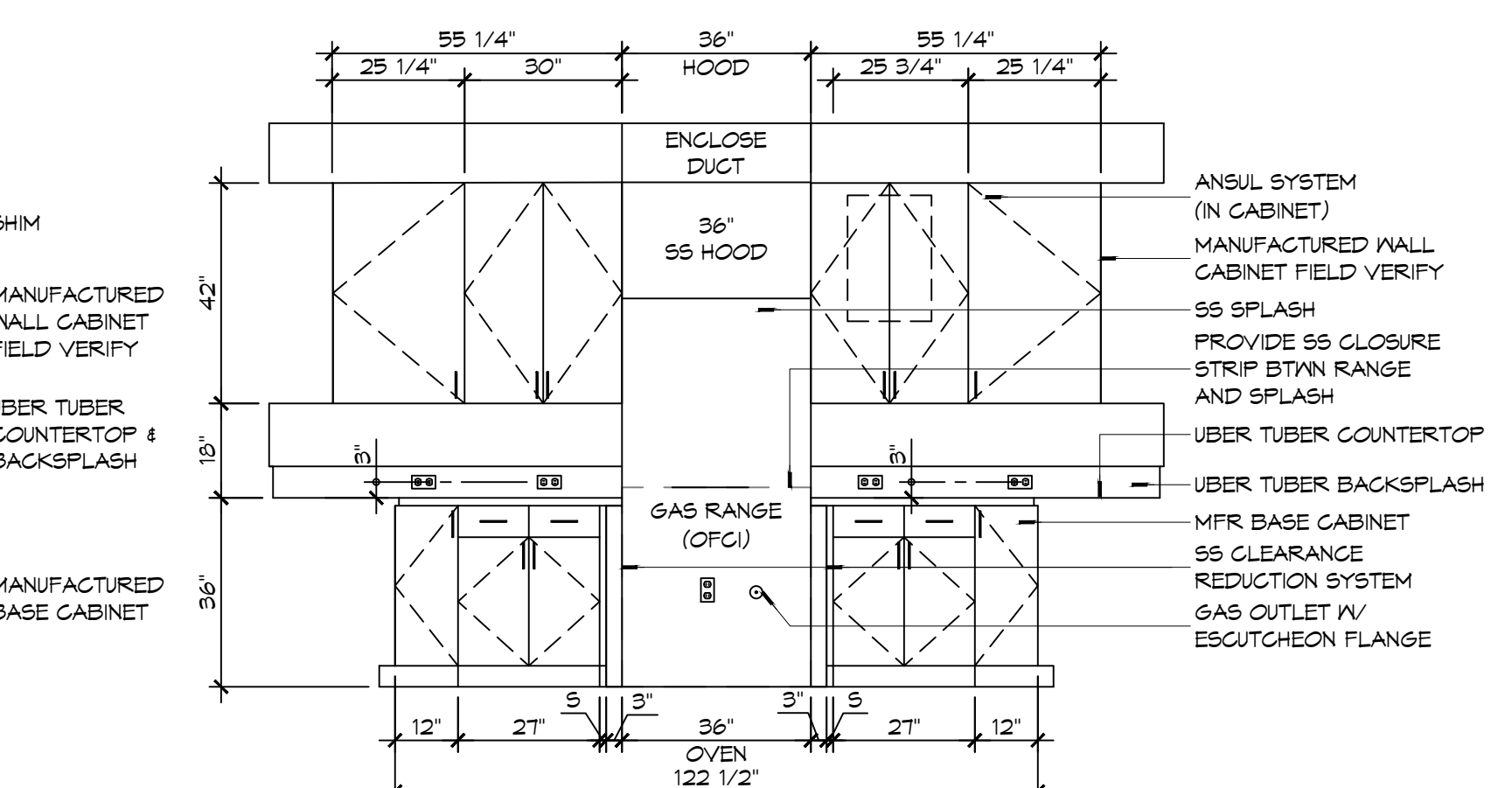

2 INTERIOR ELEVATION SCALE: 3/8" = 1'-0" KITCHEN - 103

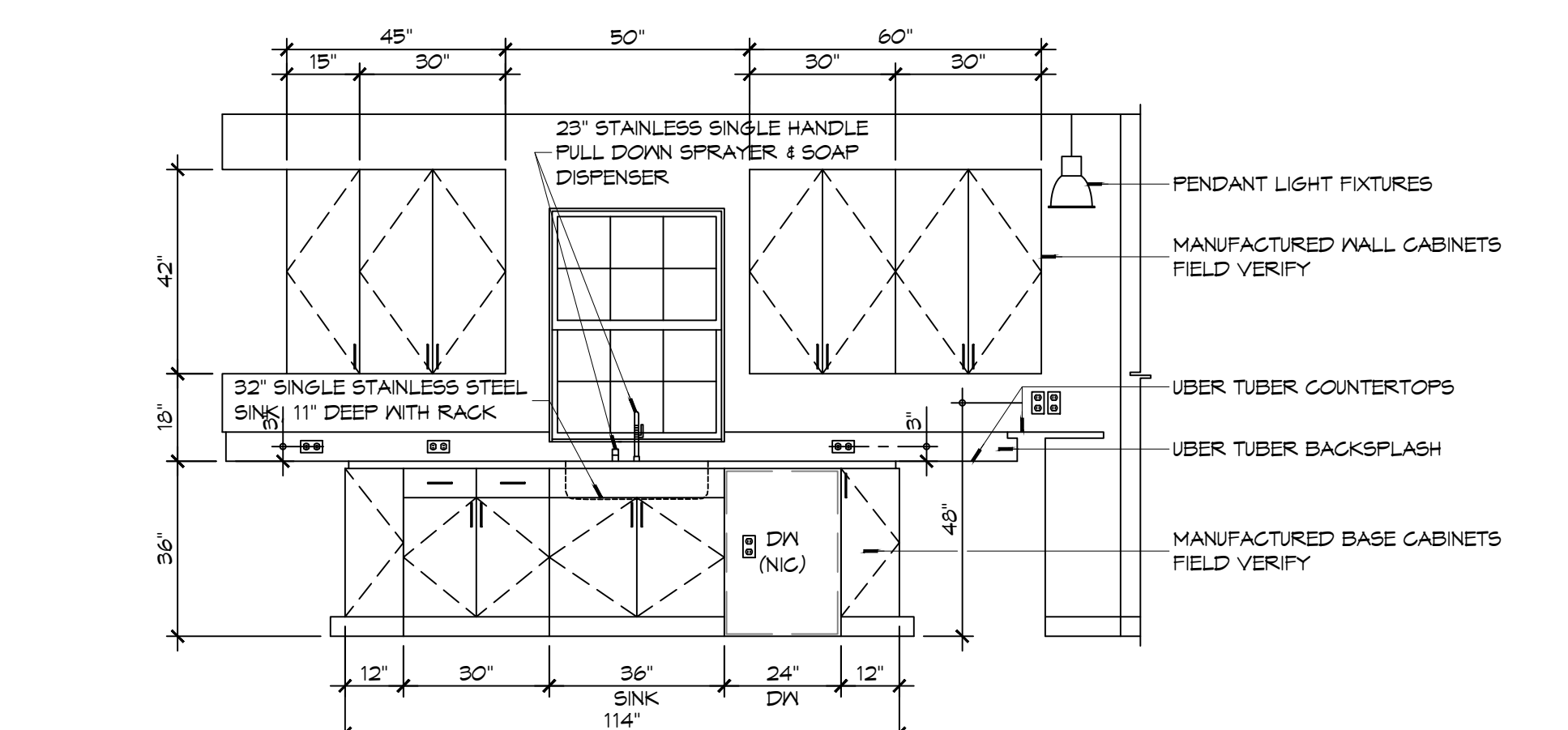

1 INTERIOR ELEVATION SCALE: 3/8" = 1'-0" KITCHEN - 103

DAMMON ENGINEERING, INC.
LOUISIANA & MISSISSIPPI

Chief Engineer: Brian Misch, PE
554 Old Spanish Trail
Slidell, LA 70458
www.dammonengineering.com
info@dammonengineering.com
PH: 985.649.5832

#	DESCRIPTION	DATE

SEAL:

NEW FIRE STATION #10
ST. TAMMANY FIRE PROTECTION DISTRICT NO. 1

246 LAKESHORE VISTA BLVD
SLIDELL, LA 70461

JOB No: 2519 DATE: 12-05-2025
DRAWN BY: CKD CHECKED BY: JMS

SHEET TITLE:
INTERIOR ELEVATIONS

DRAWING NUMBER:
A401

SHEET No: 26 of 31

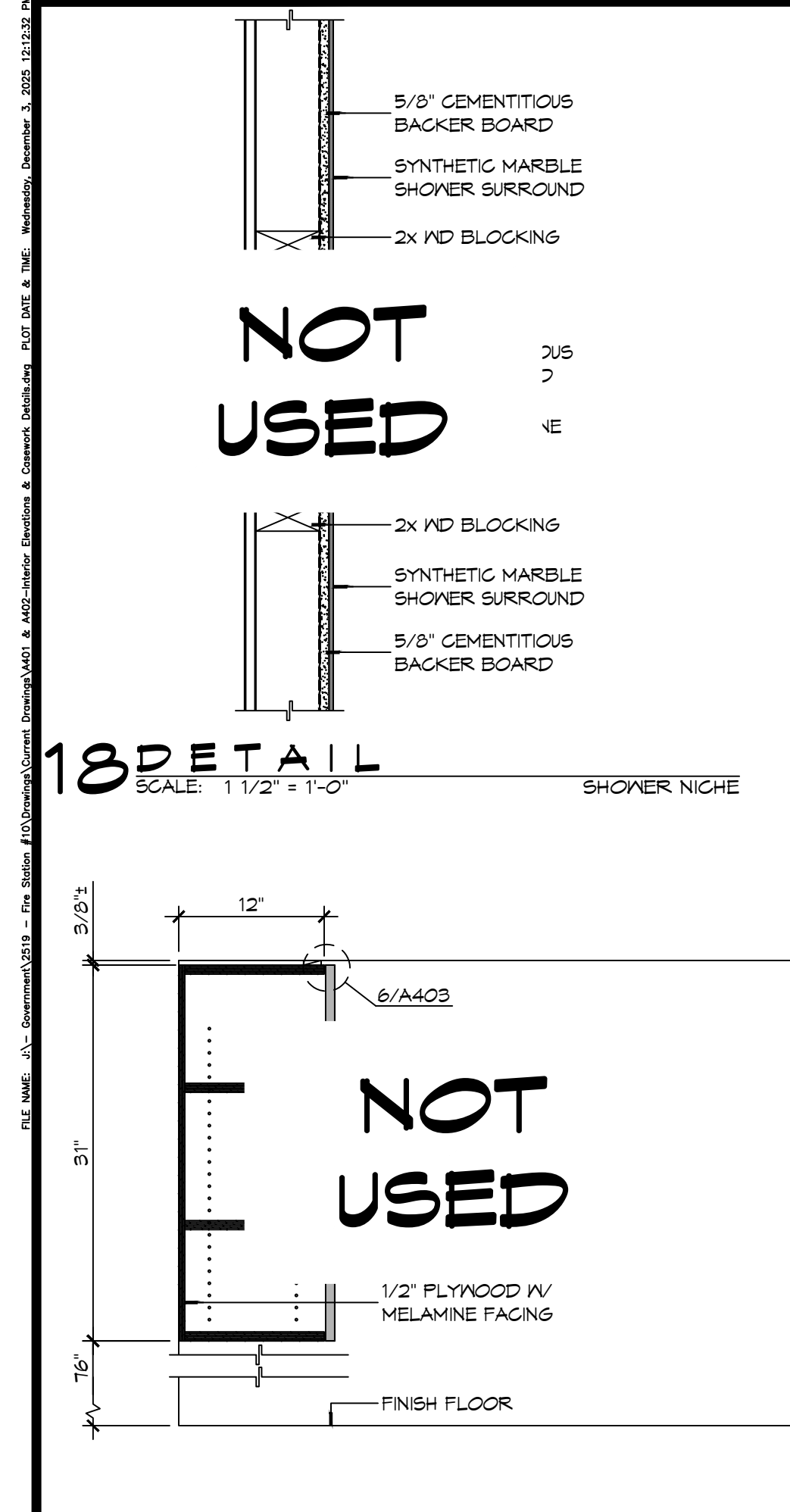

17 CASEWORK DET
SCALE: 1" = 1'-0"
KITCHEN WALL CABINET

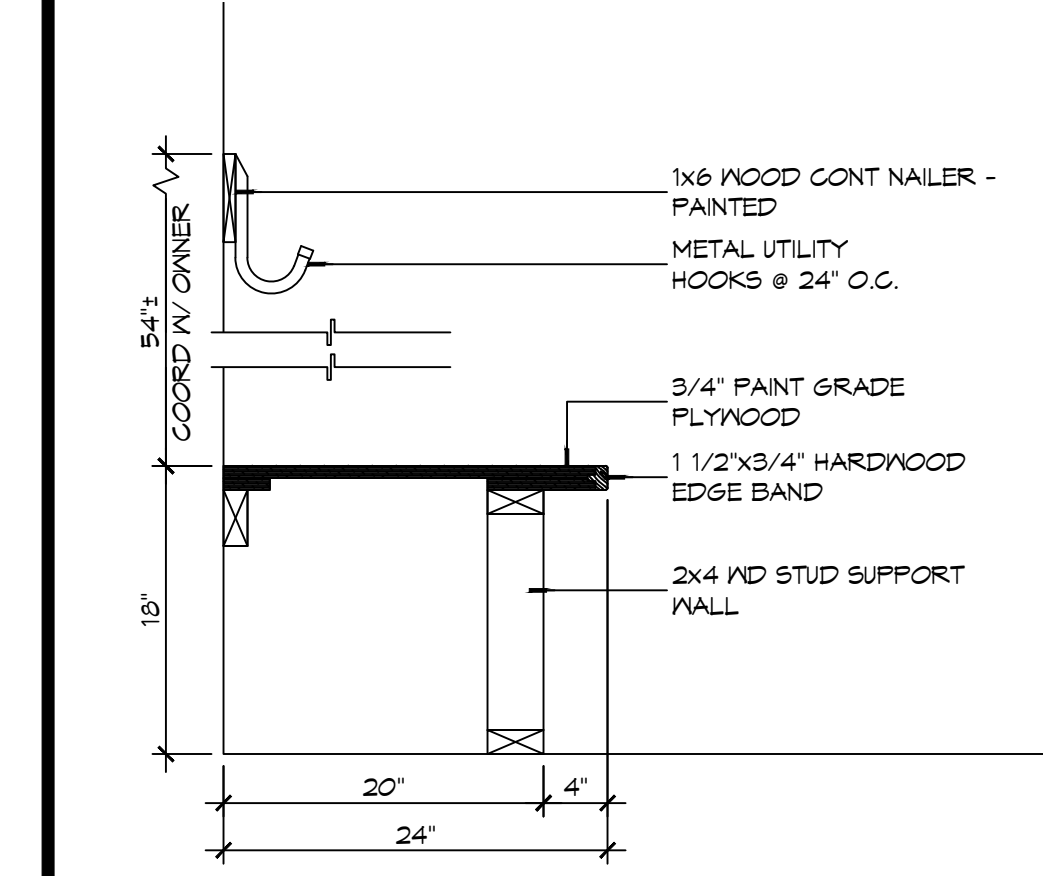

11 CASEWORK DET
SCALE: 1" = 1'-0"
GEAR ROOM

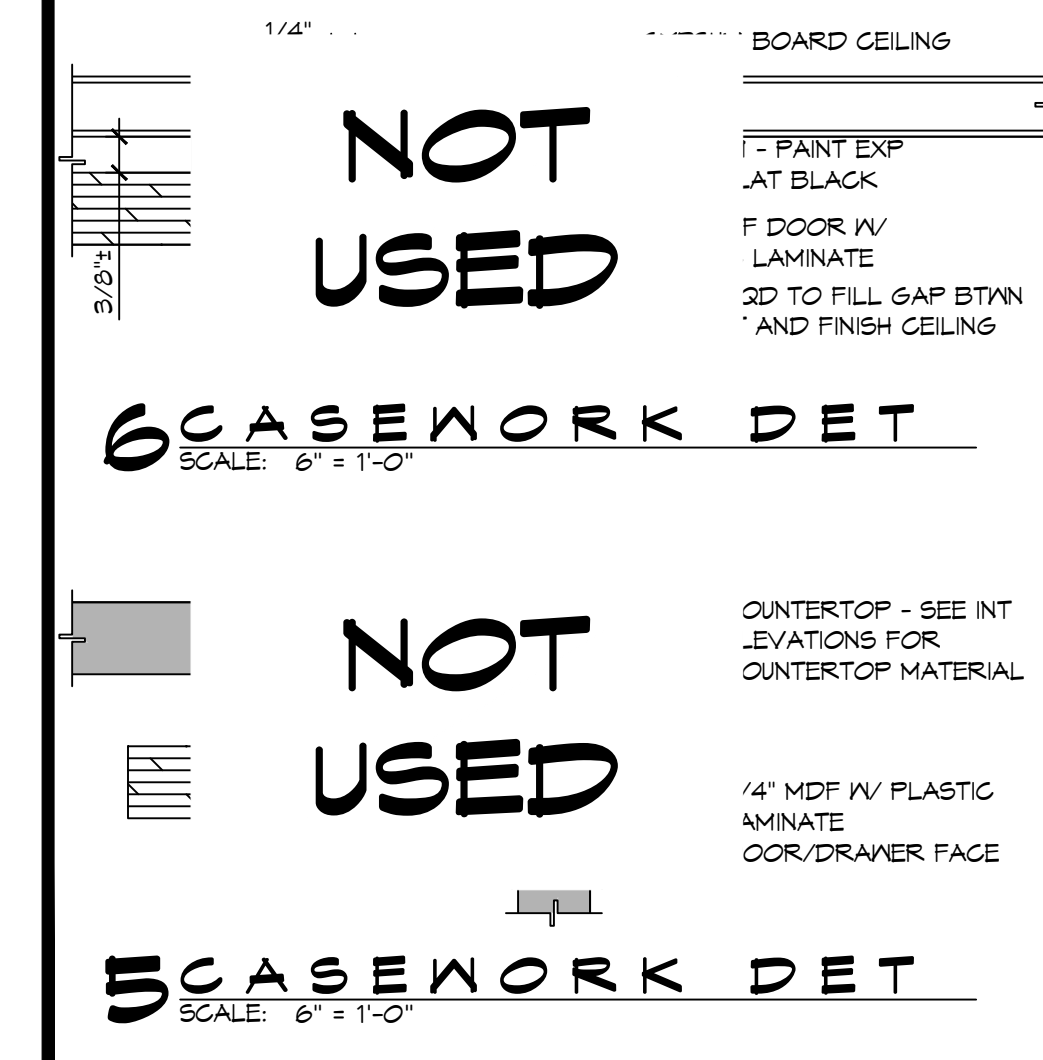

5 CASEWORK DET
SCALE: 6" = 1'-0"

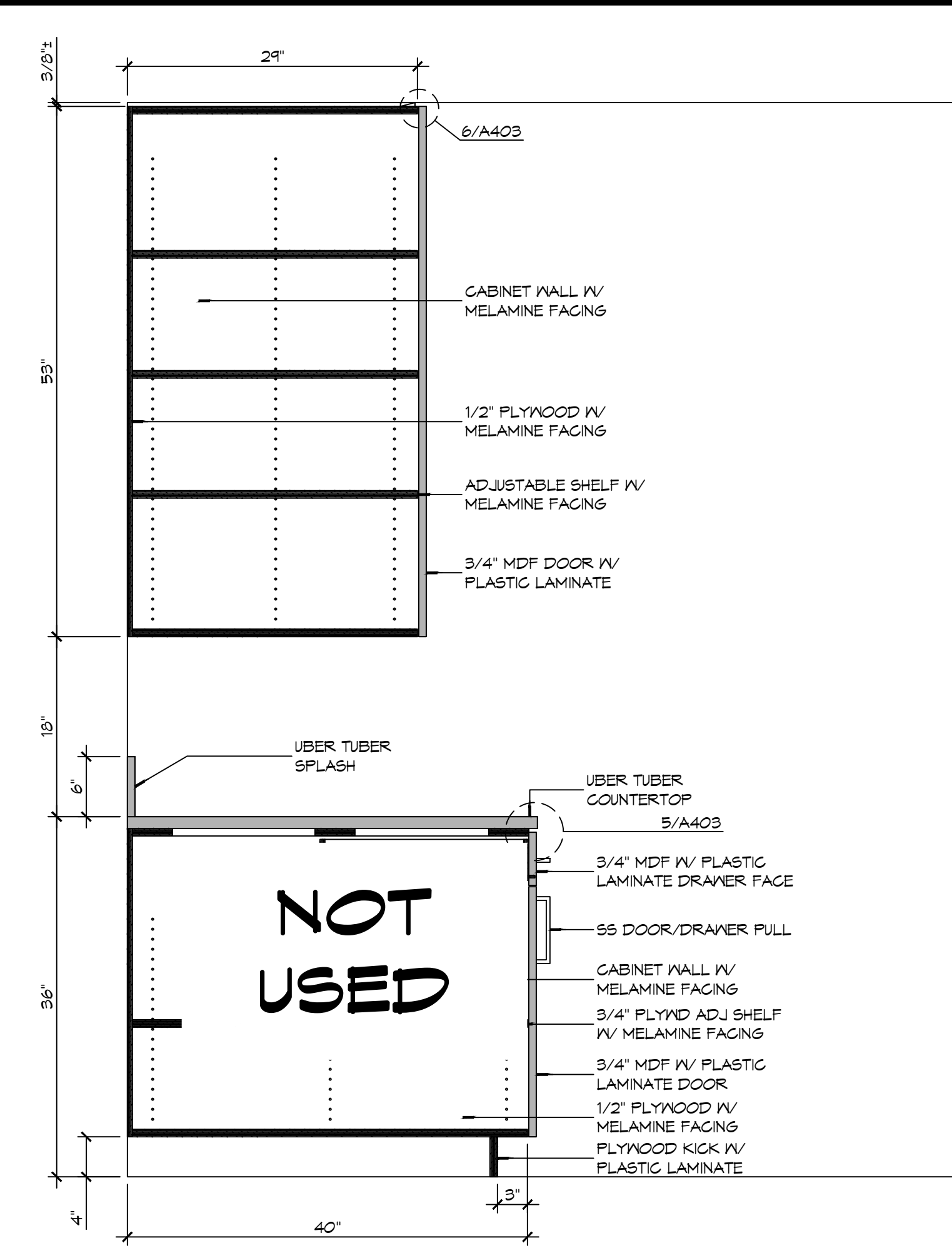

16 CASEWORK DETAIL
SCALE: 1" = 1'-0"
CABINET AT RANGE/HOOD

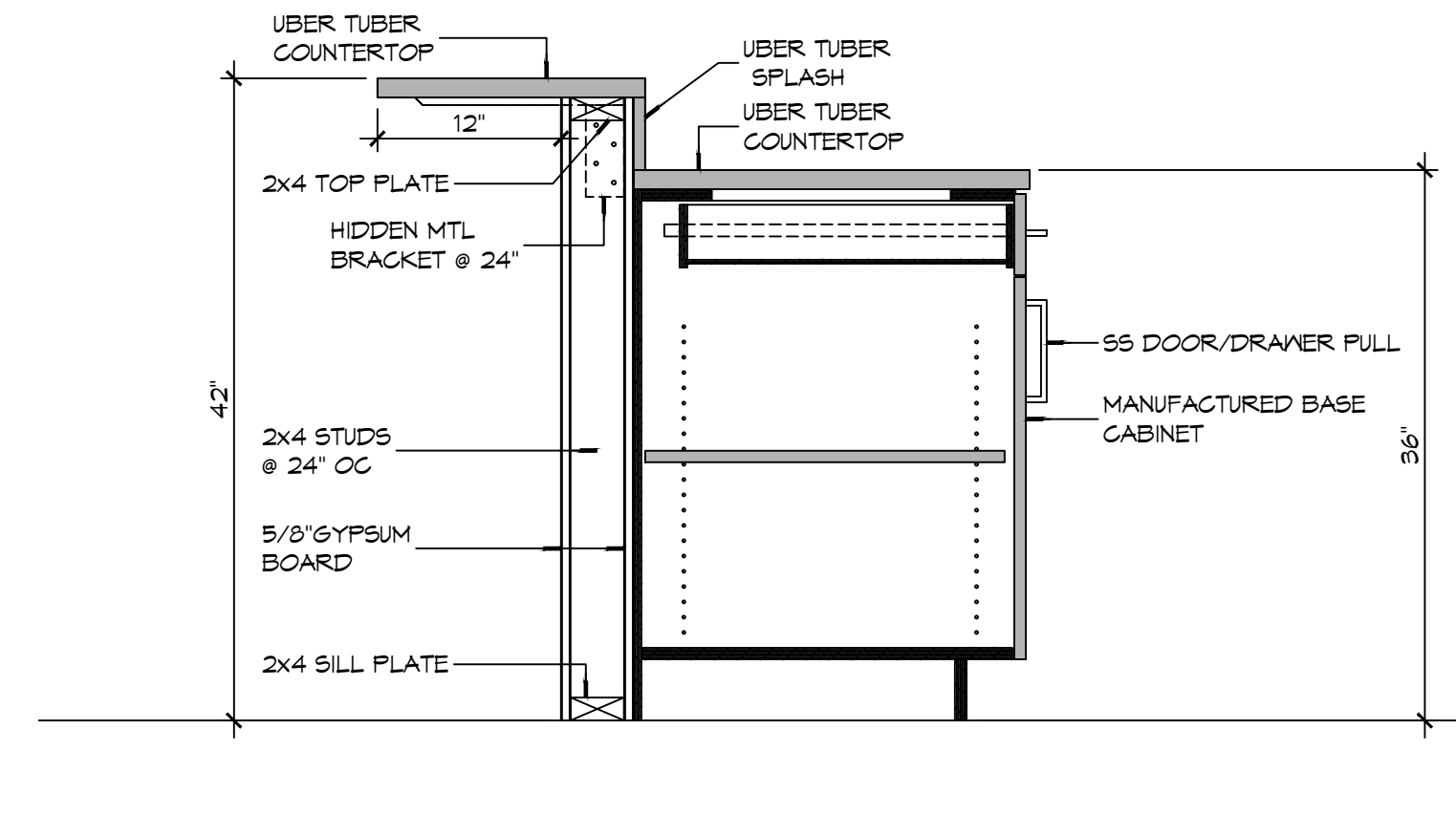

10 CASEWORK DETAIL
SCALE: 1" = 1'-0"
KITCHEN PENINSULA

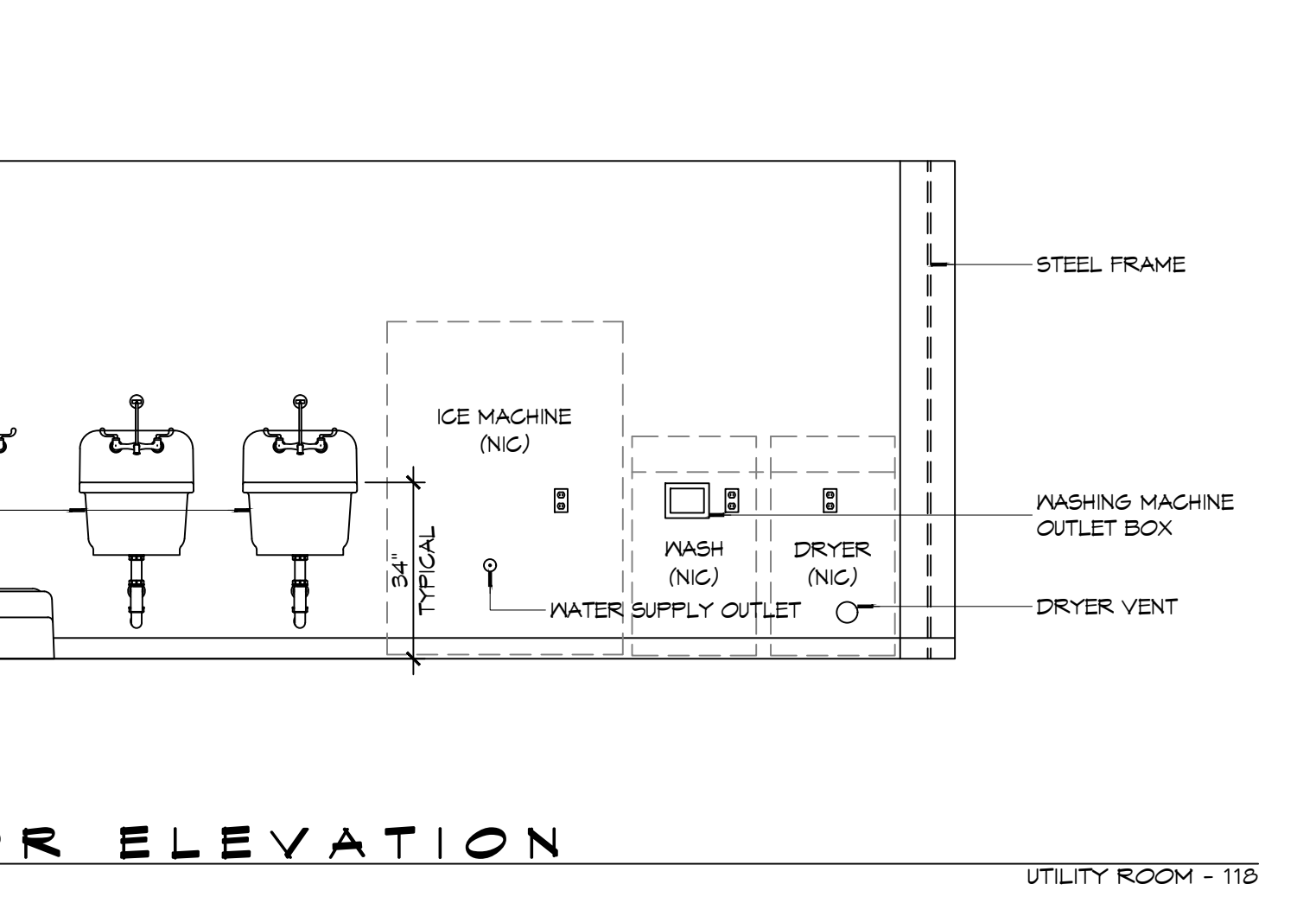

4 INTERIOR ELEVATION
SCALE: 3/8" = 1'-0"
UTILITY ROOM - 118

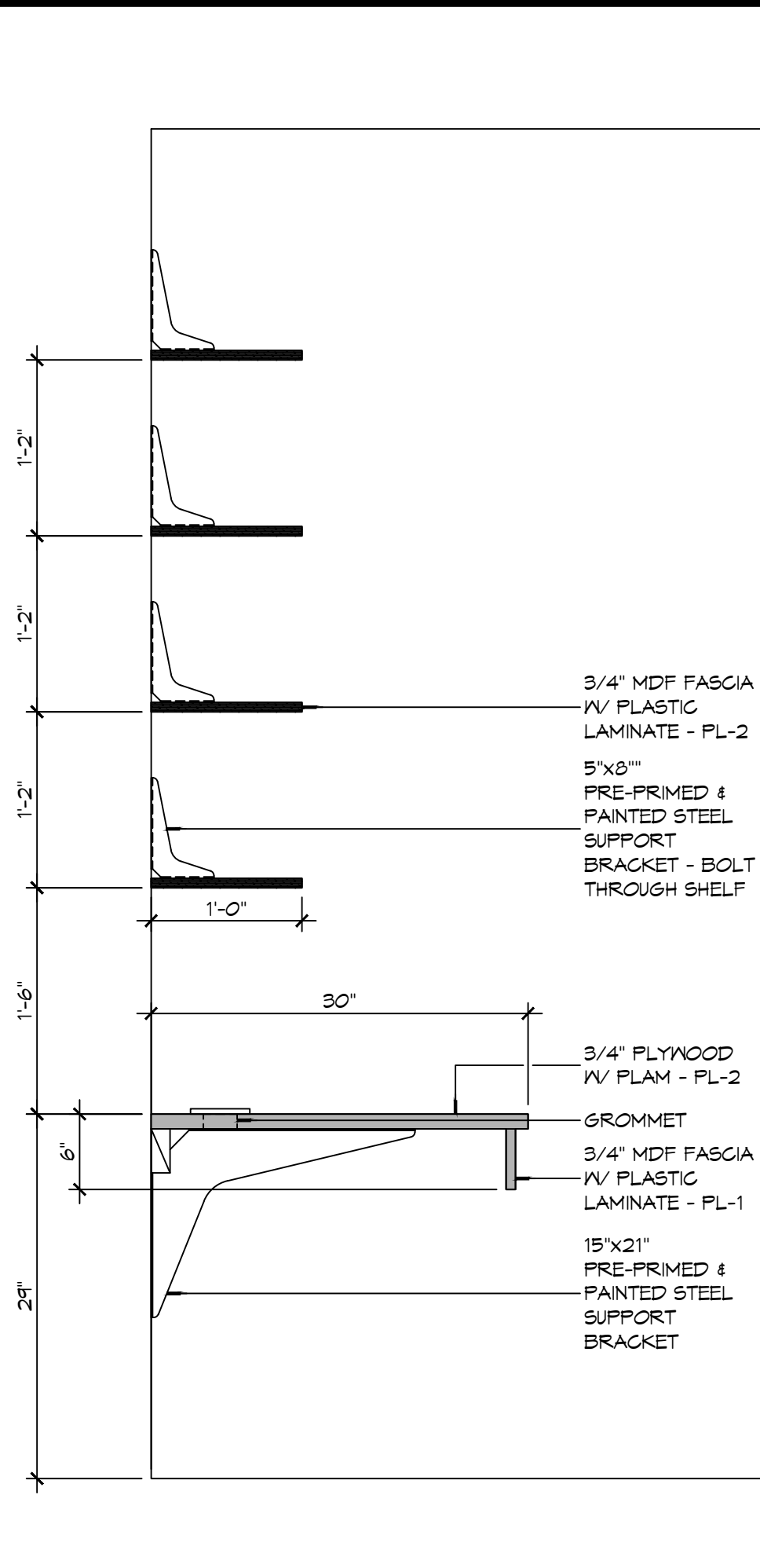

15 CASEWORK DET
SCALE: 1" = 1'-0"
BUNK ROOM

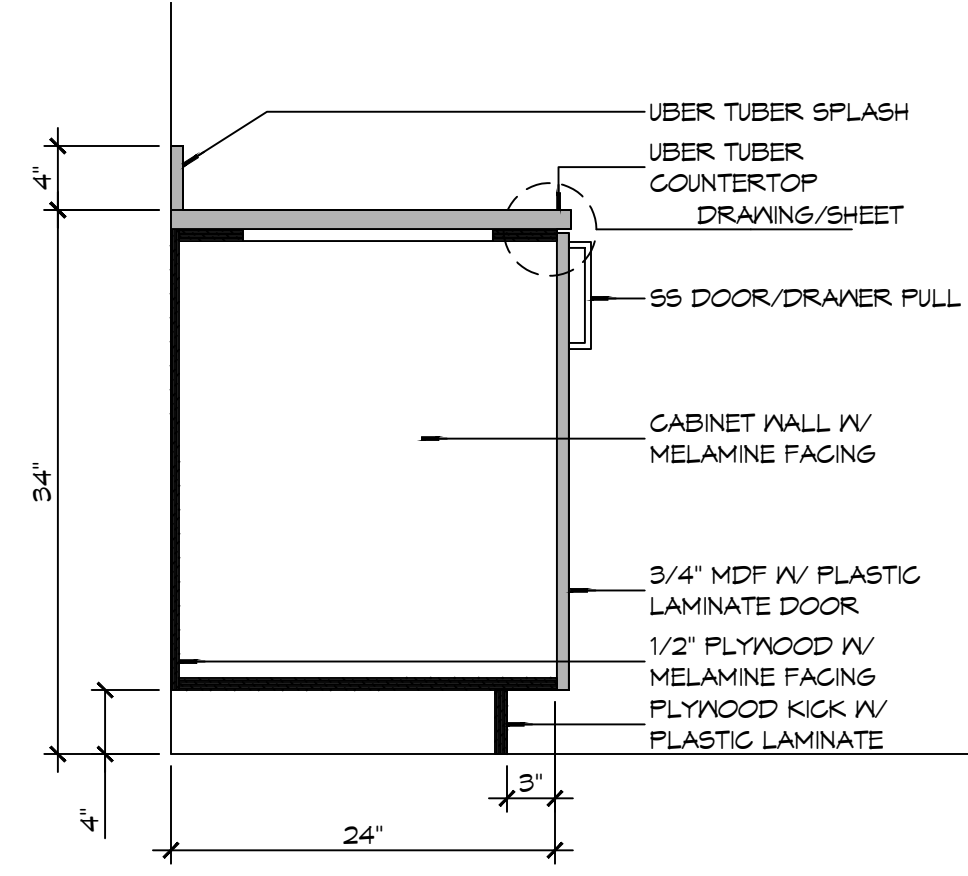

9 CASEWORK DET
SCALE: 1" = 1'-0"
LAVATORY BASE CABINET

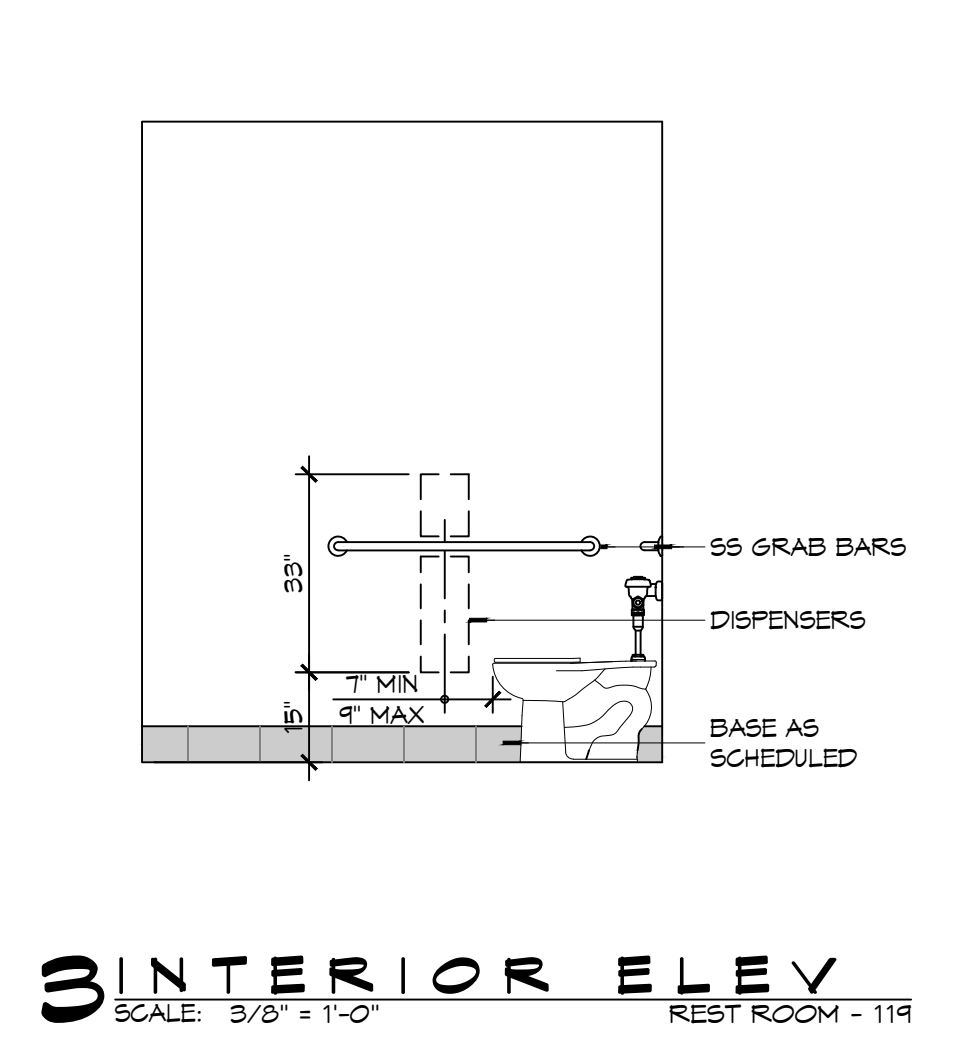

3 INTERIOR ELEV
SCALE: 3/8" = 1'-0"
REST ROOM - 119

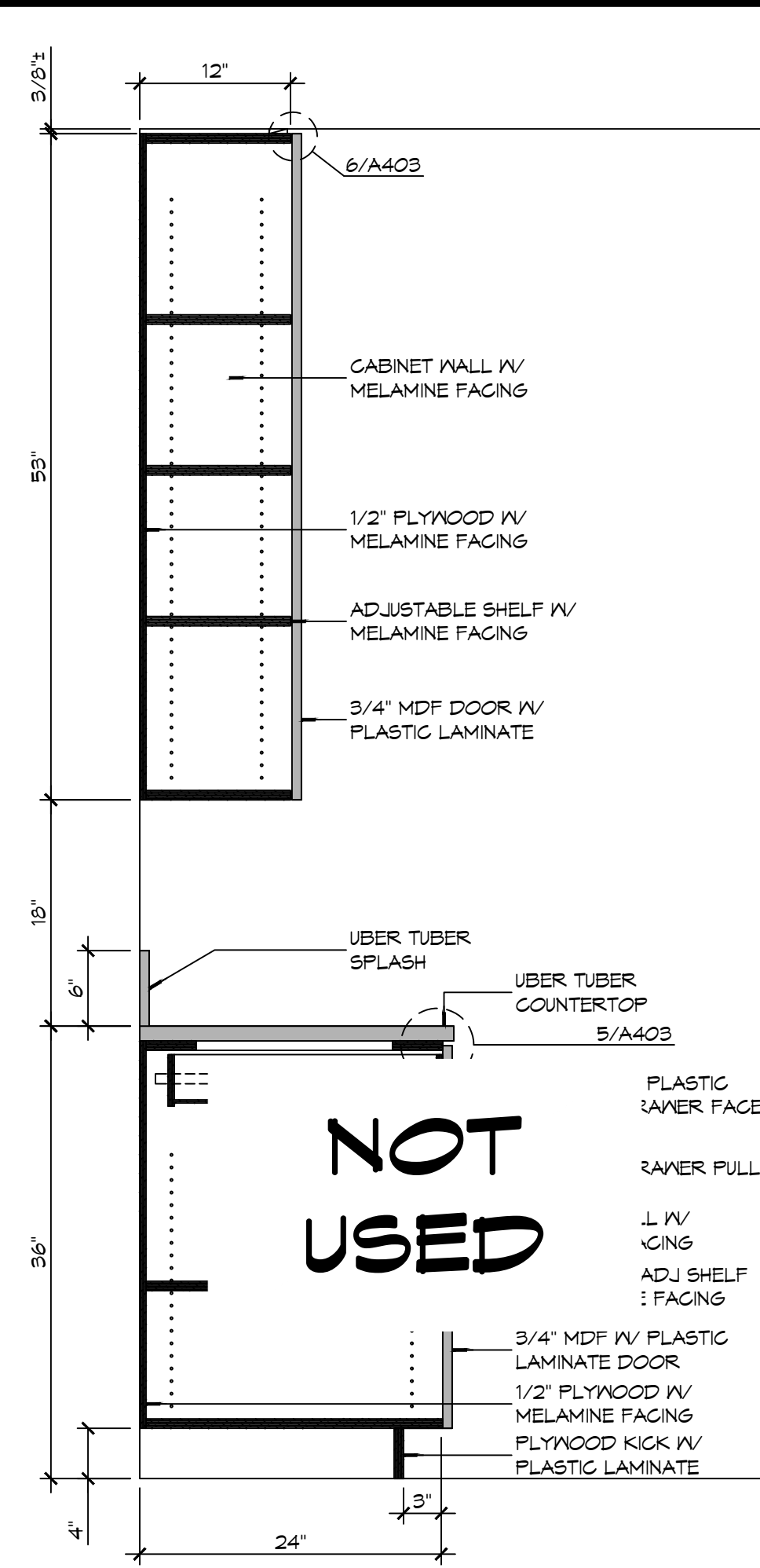

13 CASEWORK DET
SCALE: 1" = 1'-0"
TYPICAL KITCHEN CABINET

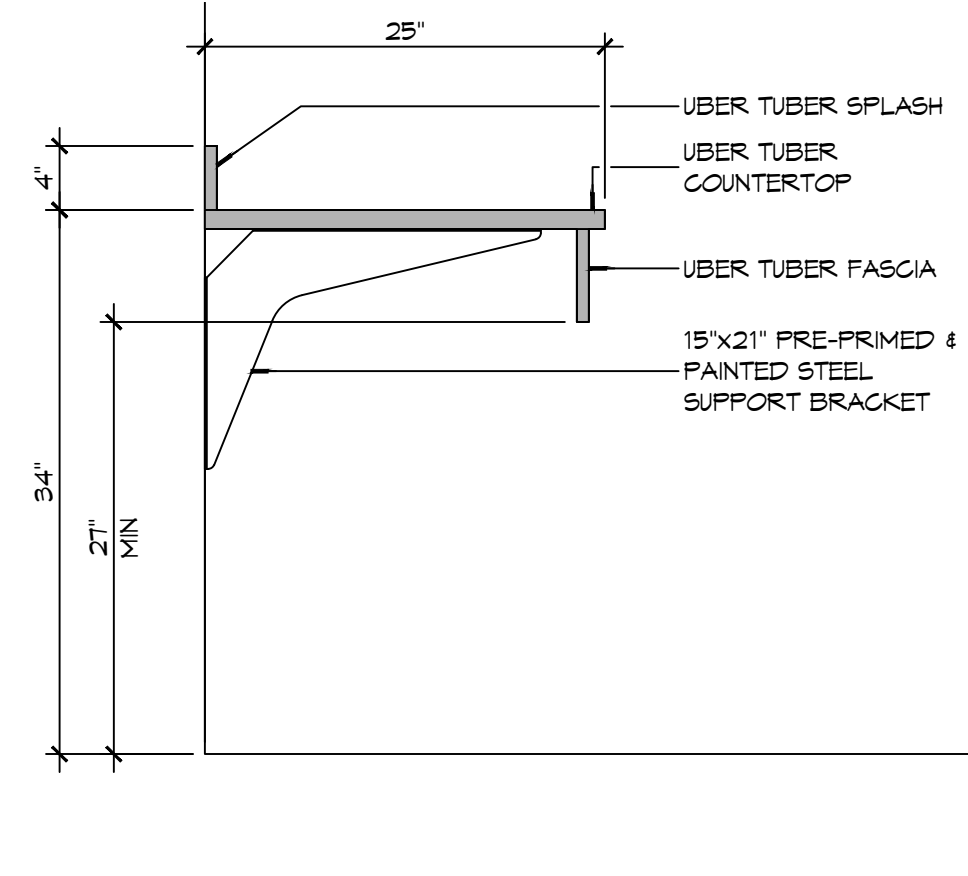

8 CASEWORK DET
SCALE: 1" = 1'-0"
LAVATORY COUNTER

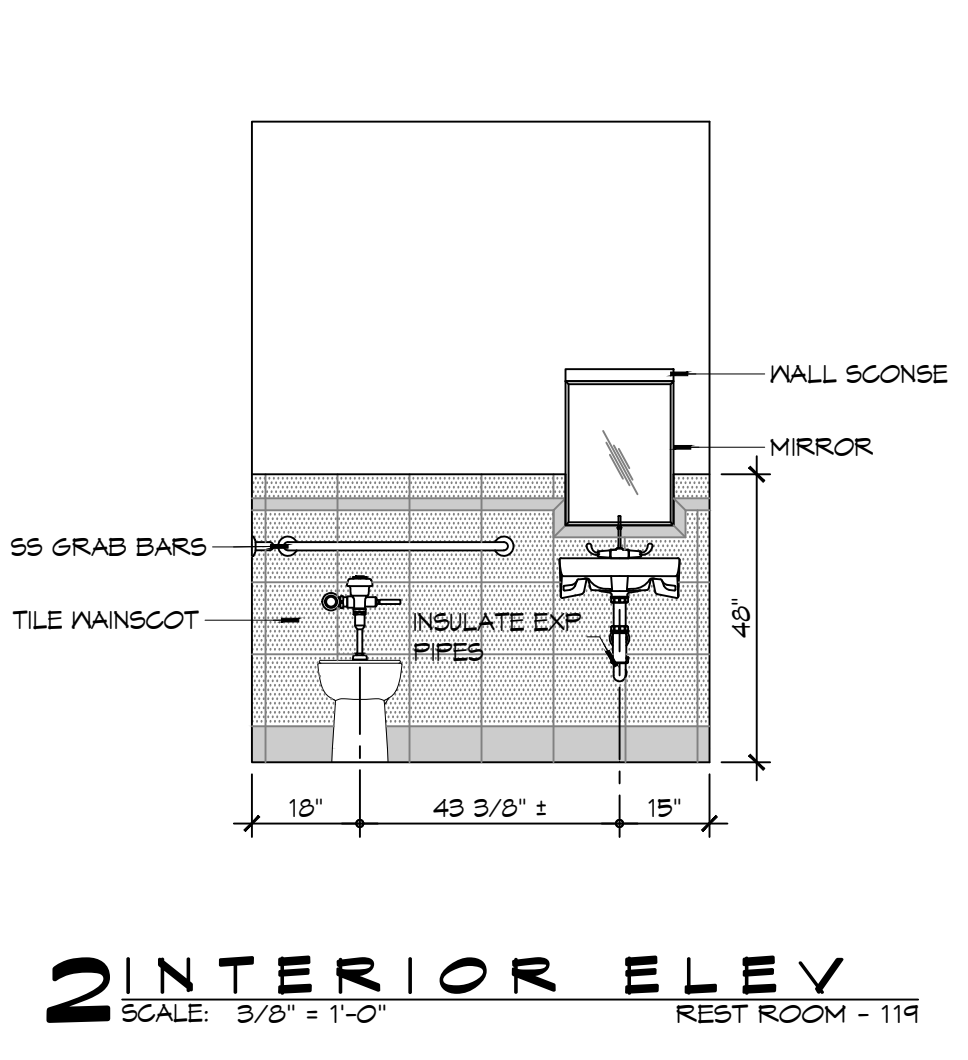

2 INTERIOR ELEV
SCALE: 3/8" = 1'-0"
REST ROOM - 119

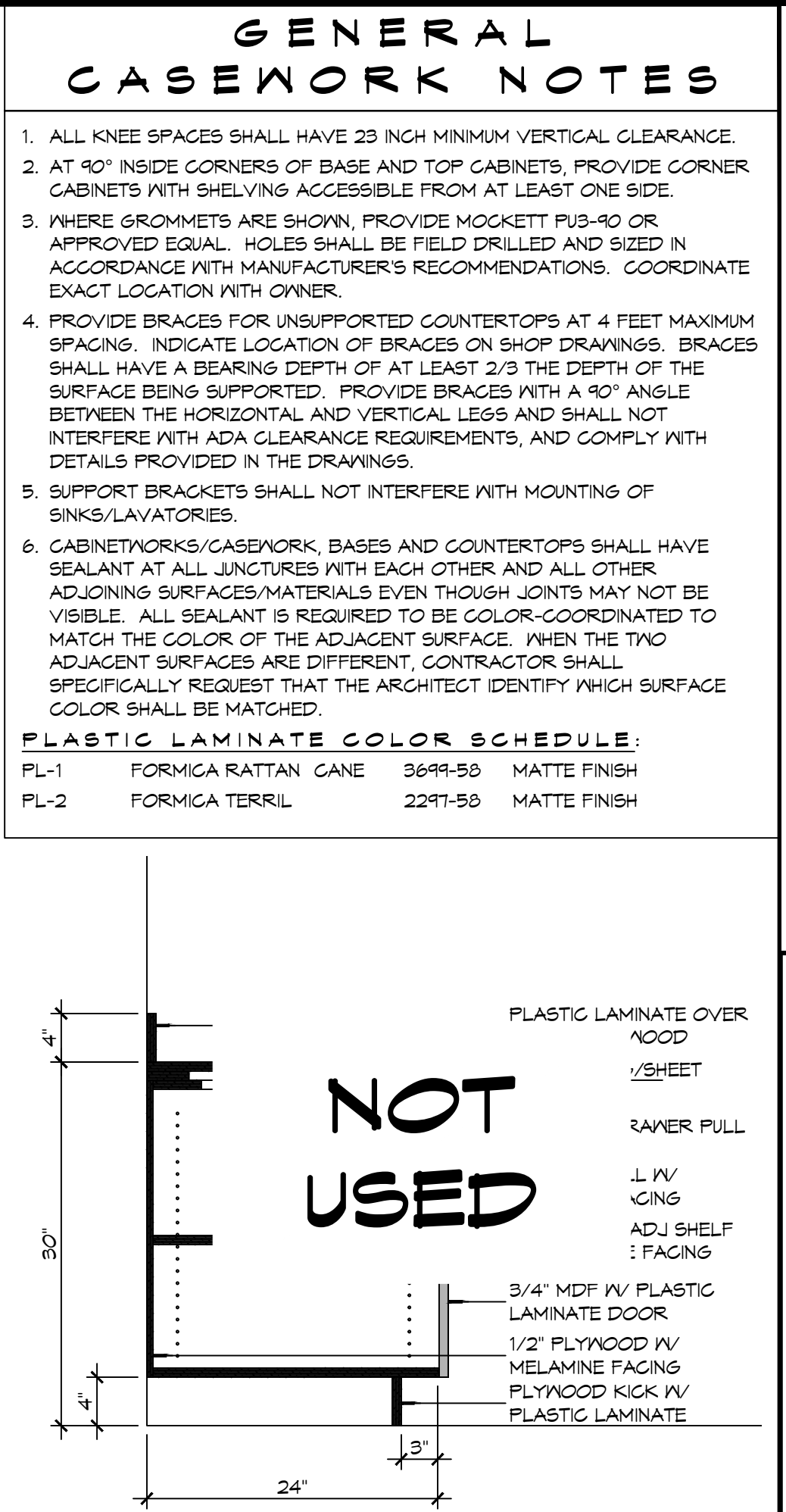

12 CASEWORK DET
SCALE: 1" = 1'-0"
DAY ROOM

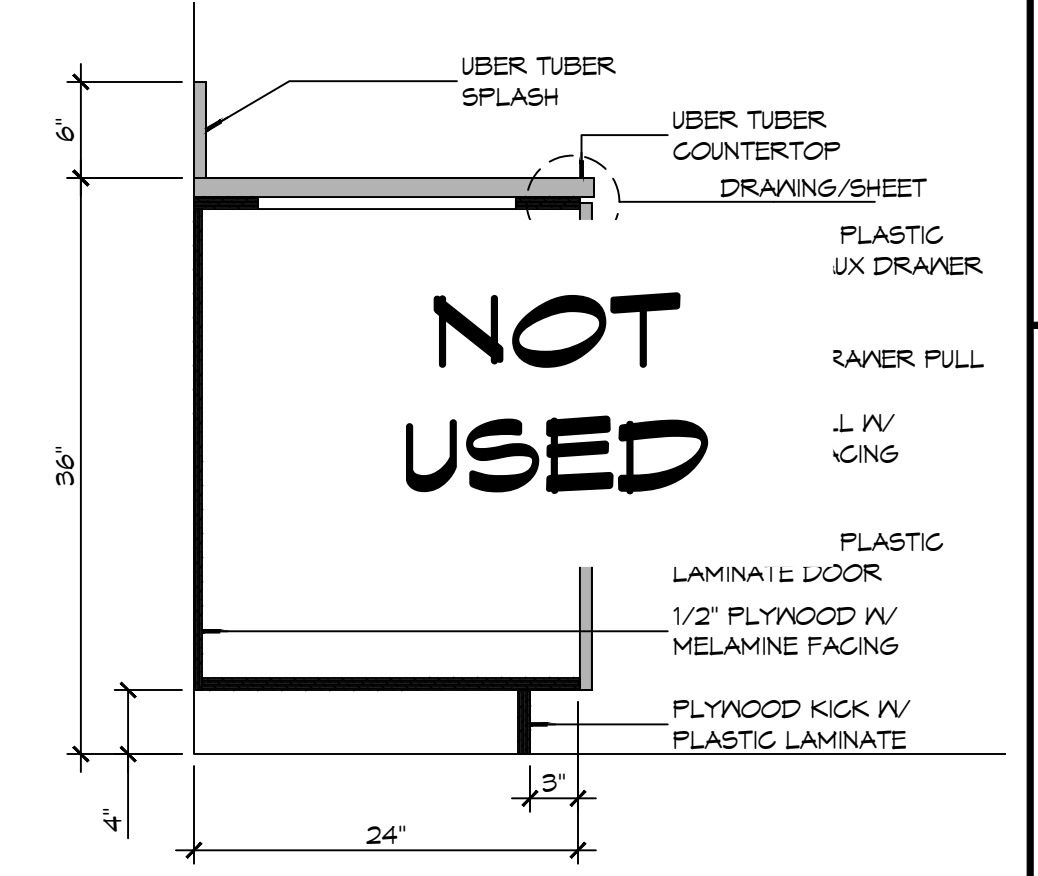

7 CASEWORK DET
SCALE: 1" = 1'-0"
KITCHEN SINK CABINET

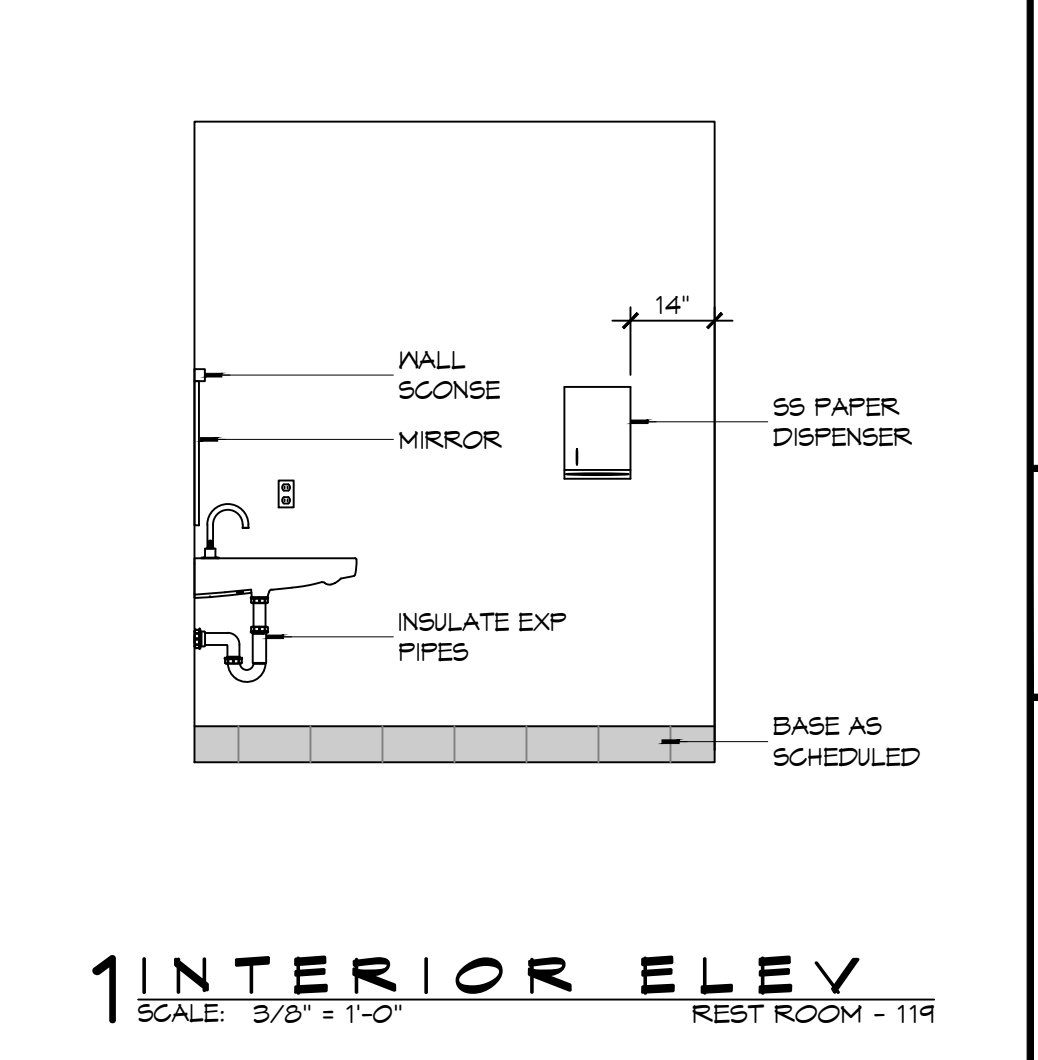

1 INTERIOR ELEV
SCALE: 3/8" = 1'-0"
REST ROOM - 119

- GENERAL CASEWORK NOTES**
- ALL KNEE SPACES SHALL HAVE 23 INCH MINIMUM VERTICAL CLEARANCE.
 - AT 90° INSIDE CORNERS OF BASE AND TOP CABINETS, PROVIDE CORNER CABINETS WITH SHELVING ACCESSIBLE FROM AT LEAST ONE SIDE.
 - WHERE GROMMETS ARE SHOWN, PROVIDE MCKETT PUS-90 OR APPROVED EQUAL. HOLES SHALL BE FIELD DRILLED AND SIZED IN ACCORDANCE WITH MANUFACTURER'S RECOMMENDATIONS. COORDINATE EXACT LOCATION WITH OWNER.
 - PROVIDE BRACES FOR UNSUPPORTED COUNTERTOPS AT 4 FEET MAXIMUM SPACING. INDICATE LOCATION OF BRACES ON SHOP DRAWINGS. BRACES SHALL HAVE A BEARING DEPTH OF AT LEAST 2/3 THE DEPTH OF THE SURFACE BEING SUPPORTED. PROVIDE BRACES WITH A 90° ANGLE BETWEEN THE HORIZONTAL AND VERTICAL LEGS AND SHALL NOT INTERFERE WITH ADA CLEARANCE REQUIREMENTS, AND COMPLY WITH DETAILS PROVIDED IN THE DRAWINGS.
 - SUPPORT BRACKETS SHALL NOT INTERFERE WITH MOUNTING OF SINKS/LAVATORIES.
 - CABINETWORKS/CASEWORK, BASES AND COUNTERTOPS SHALL HAVE SEALANT AT ALL JUNCTURES WITH EACH OTHER AND ALL OTHER ADJOINING SURFACES/MATERIALS EVEN THOUGH JOINTS MAY NOT BE VISIBLE. ALL SEALANT IS REQUIRED TO BE COLOR-COORDINATED TO MATCH THE COLOR OF THE ADJACENT SURFACE. WHEN THE TWO ADJACENT SURFACES ARE DIFFERENT, CONTRACTOR SHALL SPECIFICALLY REQUEST THAT THE ARCHITECT IDENTIFY WHICH SURFACE COLOR SHALL BE MATCHED.
- PLASTIC LAMINATE COLOR SCHEDULE:**
 PL-1 FORMICA RATTAN CANE 3699-58 MATTE FINISH
 PL-2 FORMICA TERRIL 2291-58 MATTE FINISH

DAMMON ENGINEERING, INC.
LOUISIANA & MISSISSIPPI

Chief Engineer: Brian Missett, PE
 554 Old Spanish Trail
 Slidell, LA 70458
 www.dammonengineering.com
 info@dammonengineering.com
 PH: 985-649-5832

#	DESCRIPTION	REVISIONS	DATE

SEAL:

**NEW FIRE STATION #10
ST. TAMMANY FIRE PROTECTION DISTRICT NO. 1**

248 LAKESHORE VISTA BLVD
 SLIDELL, LA 70461
 JOB NO: 2519
 DATE: 12-05-2025
 DRAWN BY: JMS
 CHECKED BY: CKD

SHEET TITLE:
INTERIOR ELEVATIONS AND CASEWORK DETAILS

DRAWING NUMBER:
A402

SHEET No: 26 of 37

FILE NAME: J:_Common\A501 - Fire Barrier.dwg DATE: 12/05/2025 10:46:41 AM

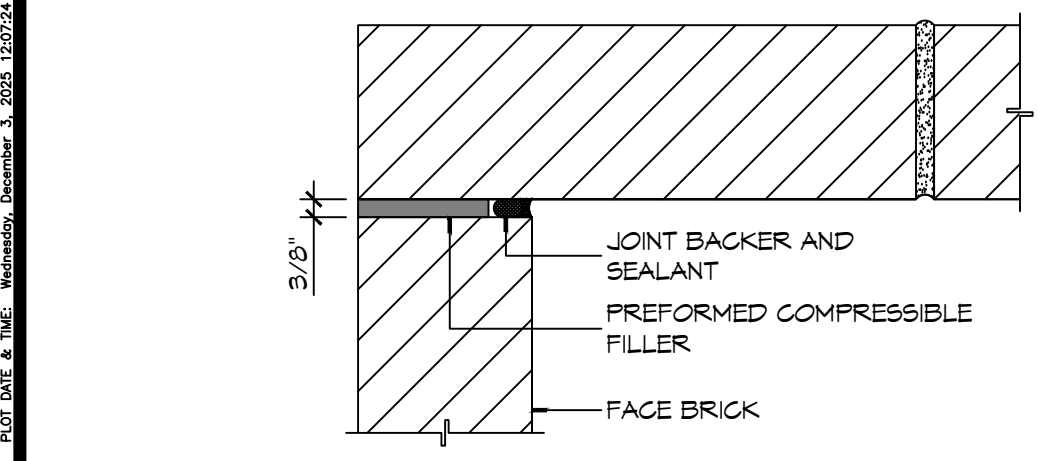

B INSIDE MASONRY CORNER

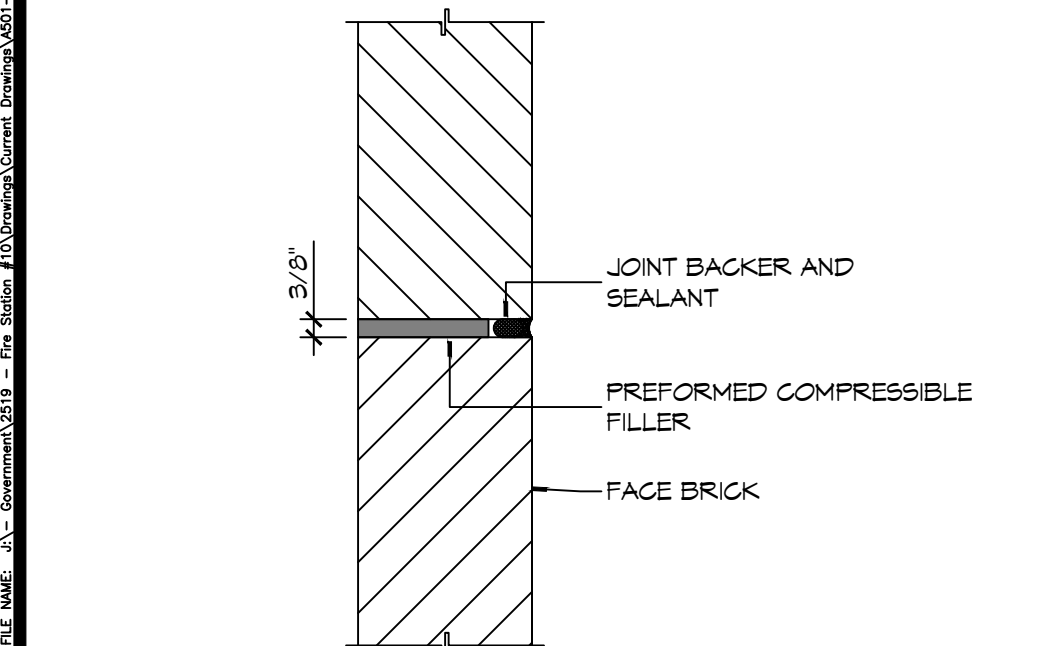

A IN-LINE MASONRY

NOT USED

NOT USED

8 DETAIL
SCALE: 3" = 1'-0" TYPICAL MASONRY CONTROL JOINT

7 DETAIL
SCALE: 1 1/2" = 1'-0" MASONRY SHELF ANGLE AT ROOF

6 DETAIL
SCALE: 1 1/2" = 1'-0" MASONRY SHELF ANGLE AT ROOF

5 LADDER DETAILS
SCALE: 1/2" = 1'-0"

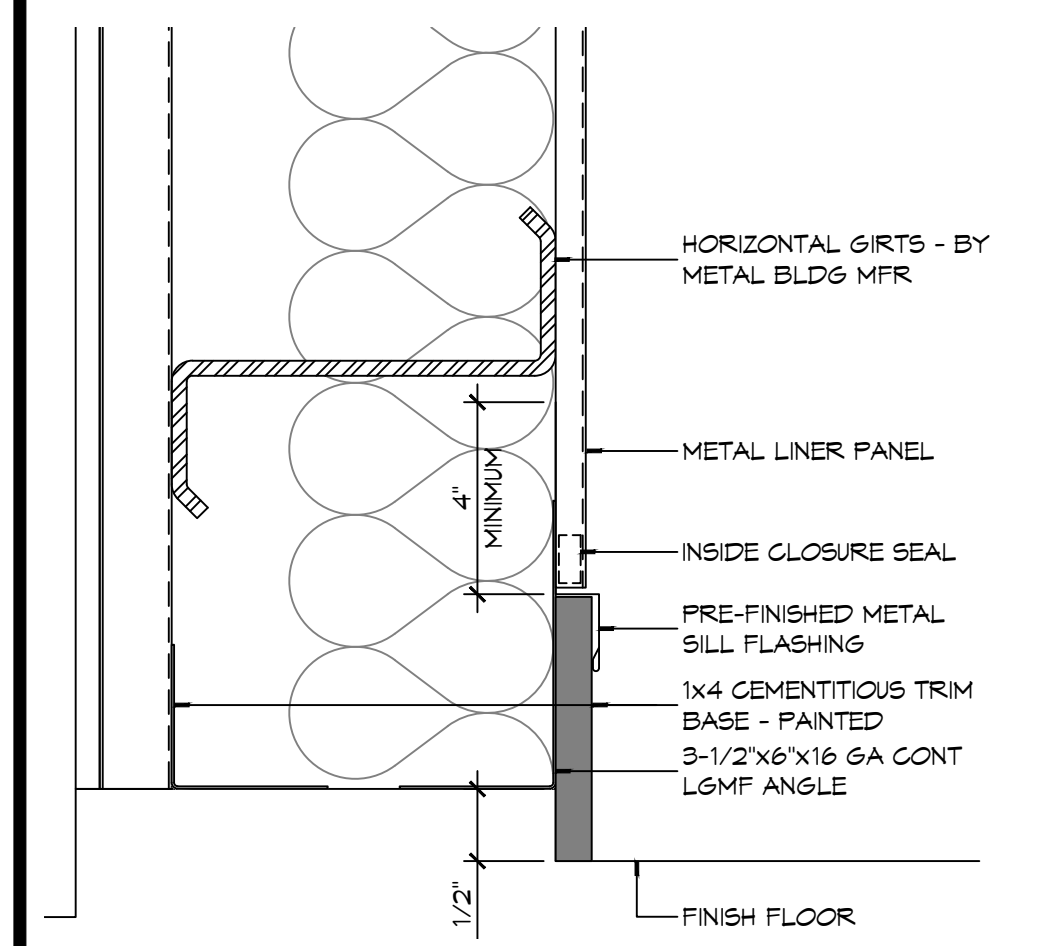

4 DETAIL
SCALE: 3" = 1'-0" TYPICAL BASE/LINER PANEL JUNCTION

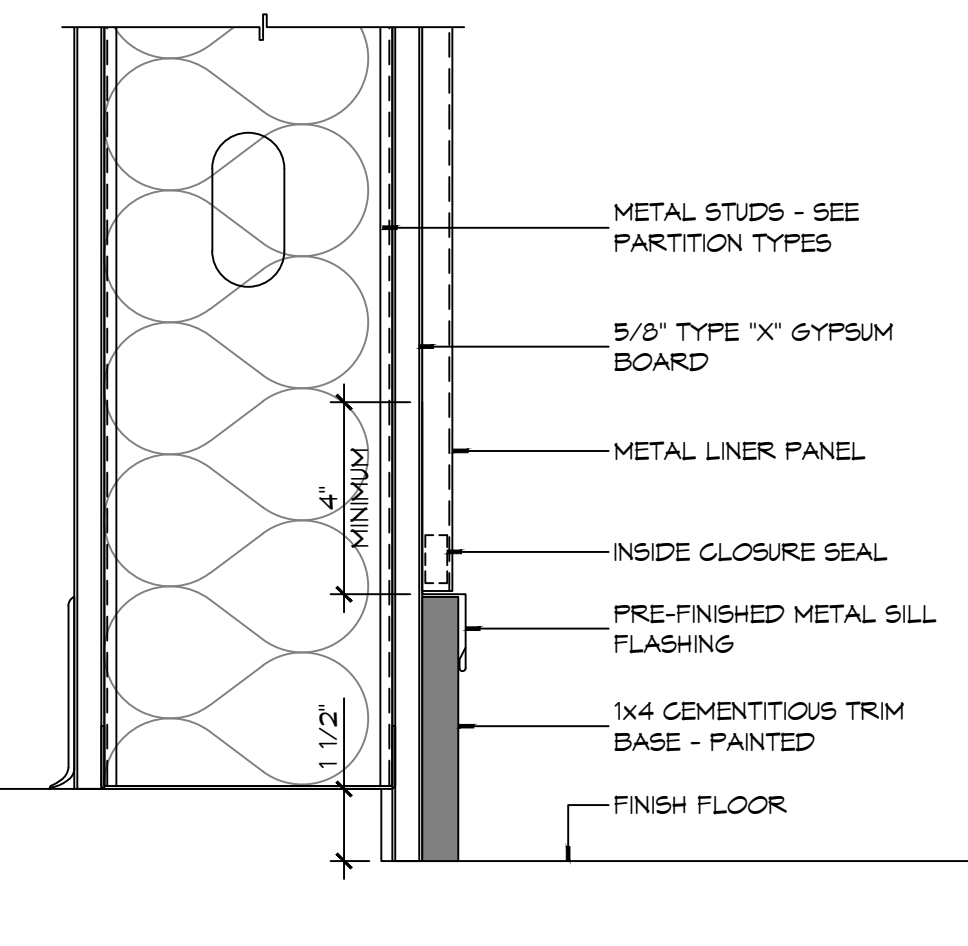

3 DETAIL
SCALE: 3" = 1'-0" TYPICAL BASE/LINER PANEL JUNCTION

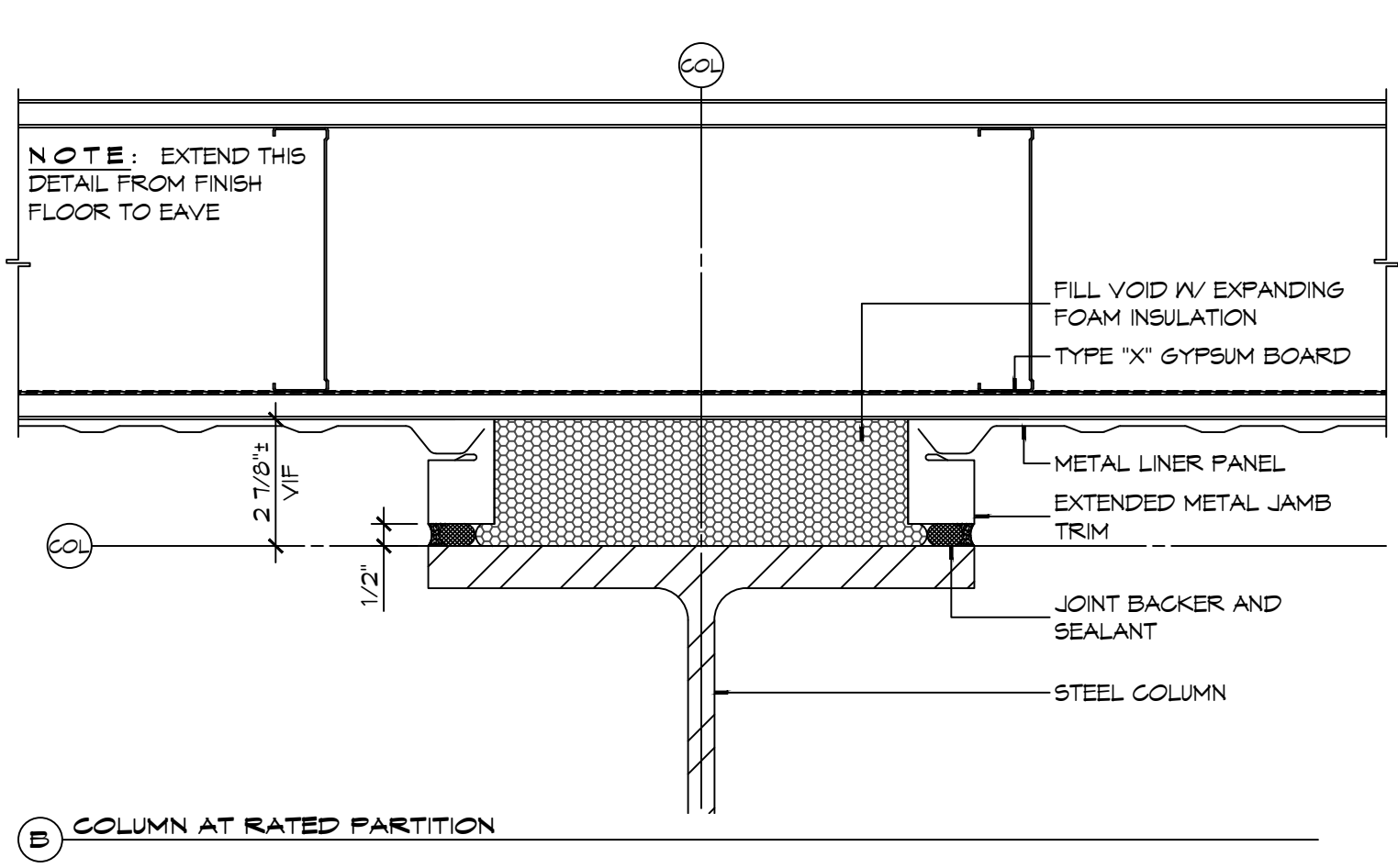

2 PLAN DETAILS
SCALE: 3" = 1'-0"

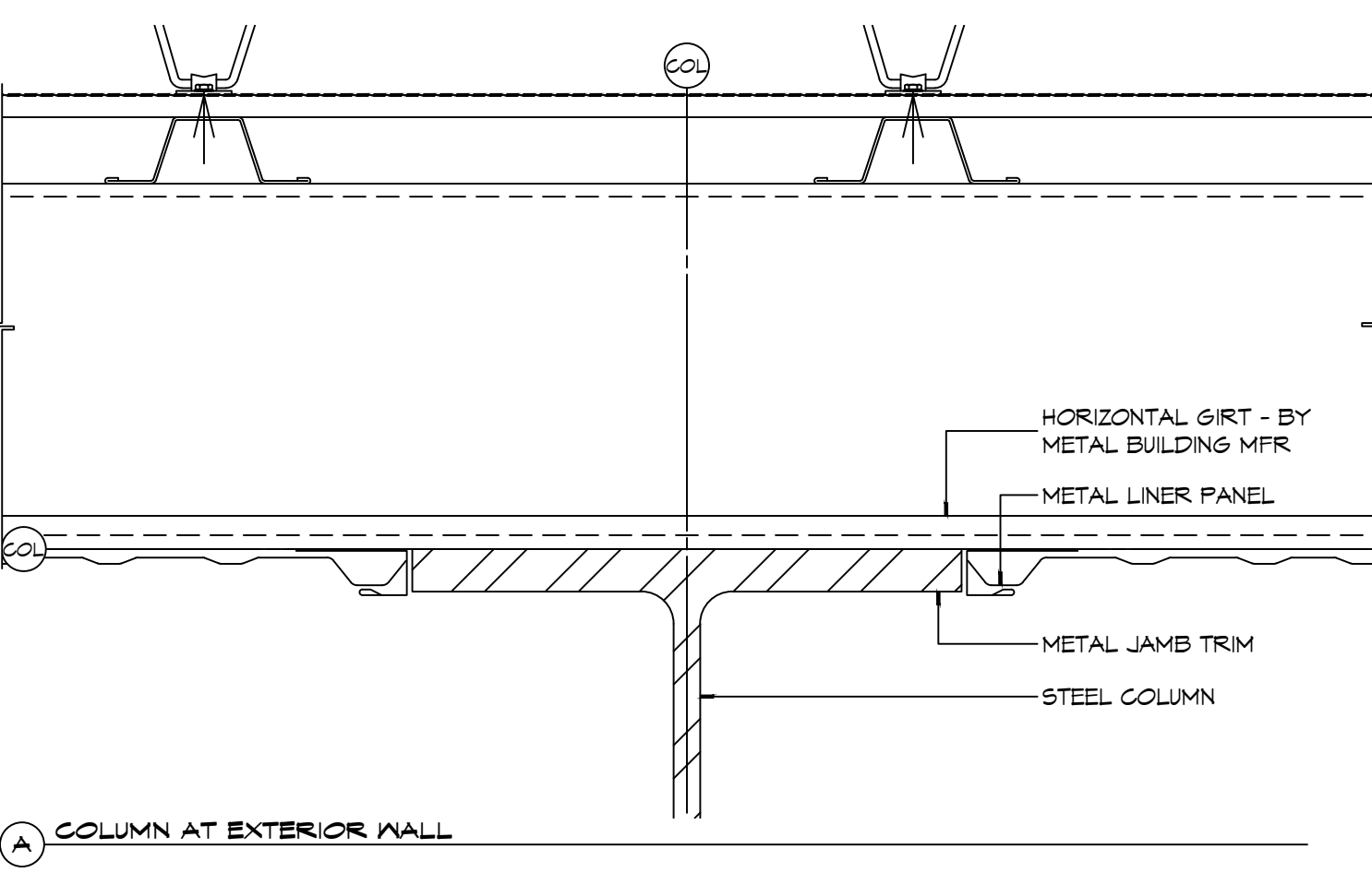

A COLUMN AT EXTERIOR WALL
TYPICAL COLUMN/LINER PANEL JUNCTION

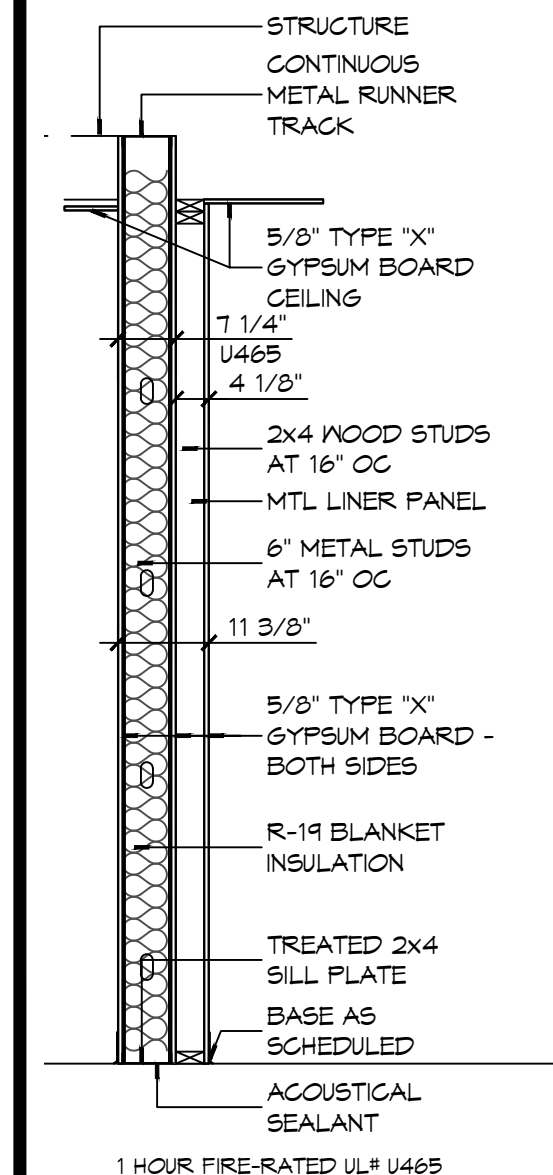

P1
1 HOUR FIRE-RATED ULF U465

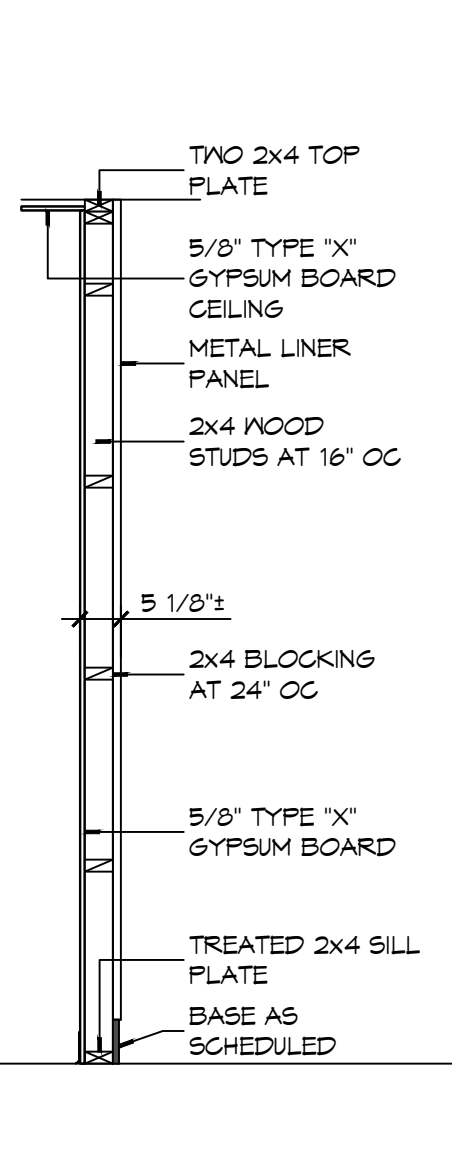

P2
SMOKE PARTITION

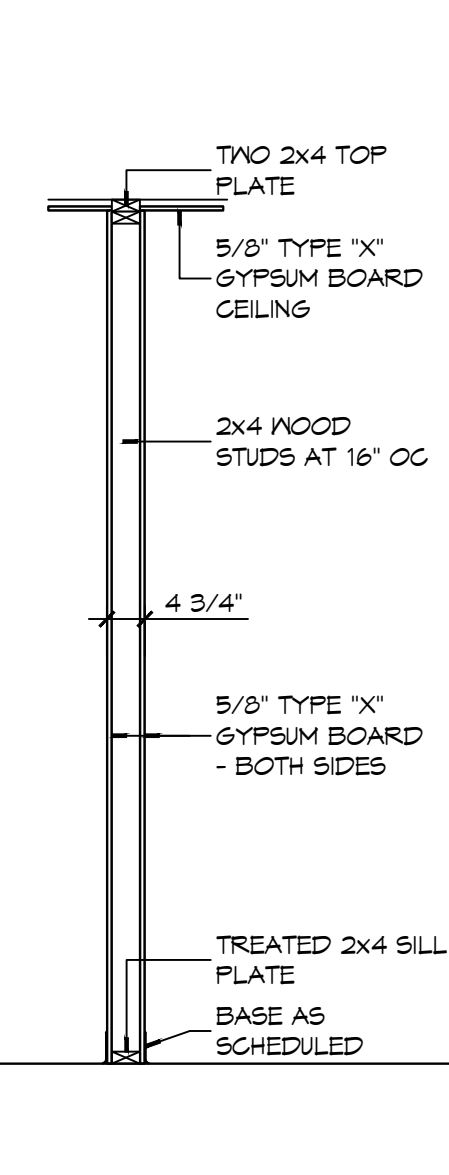

P3

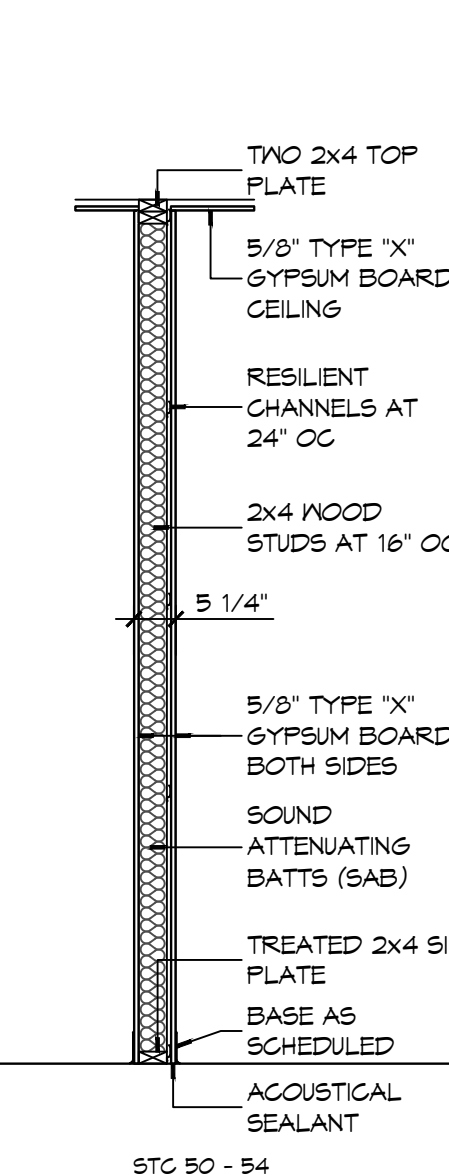

P4

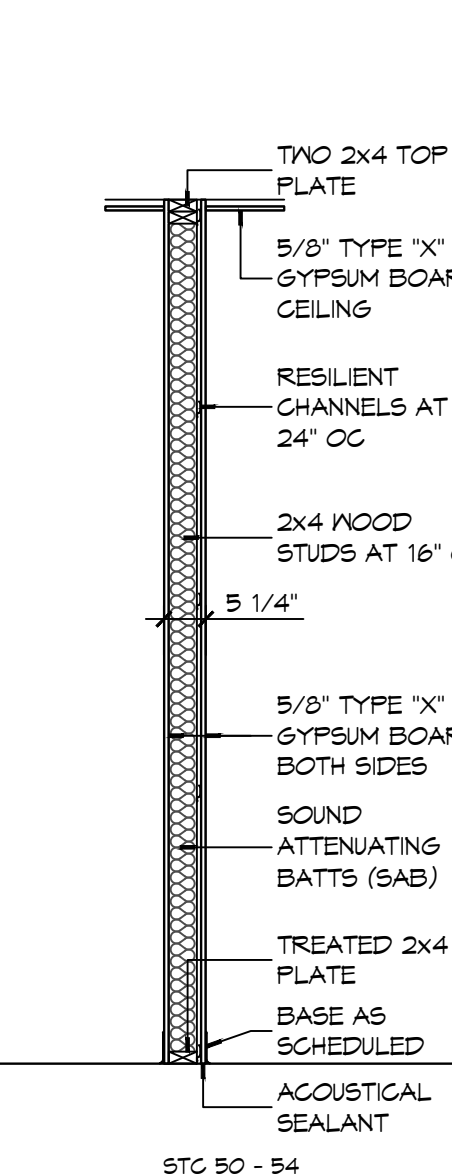

P5

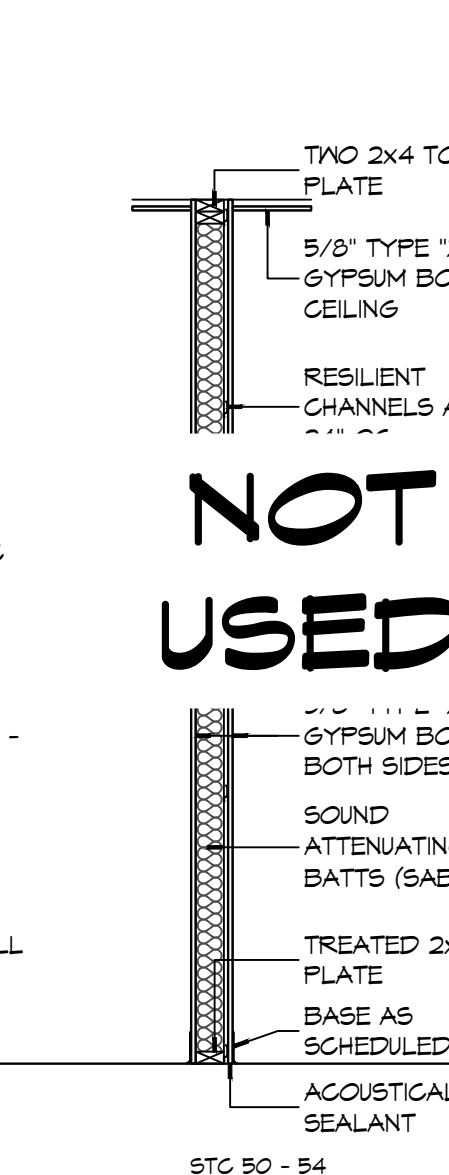

P6

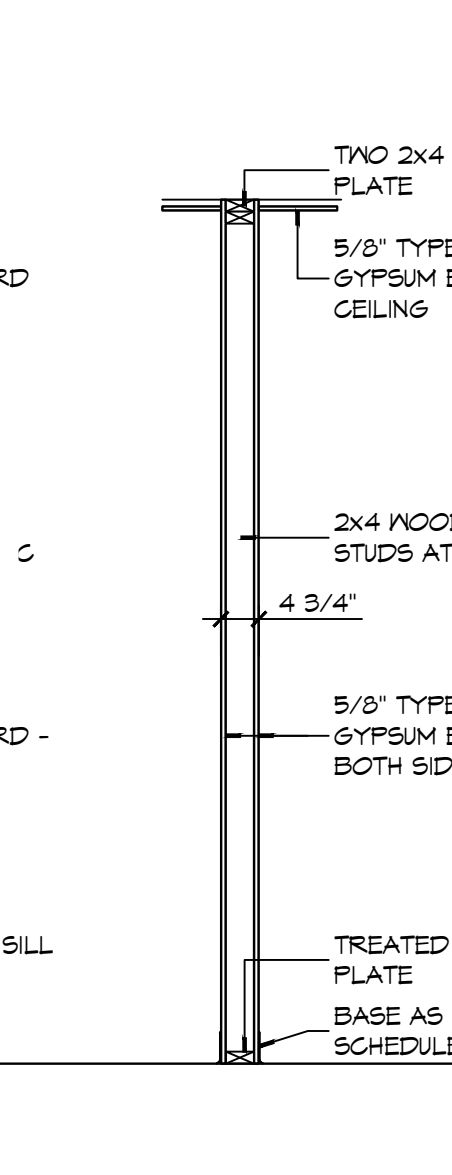

P7

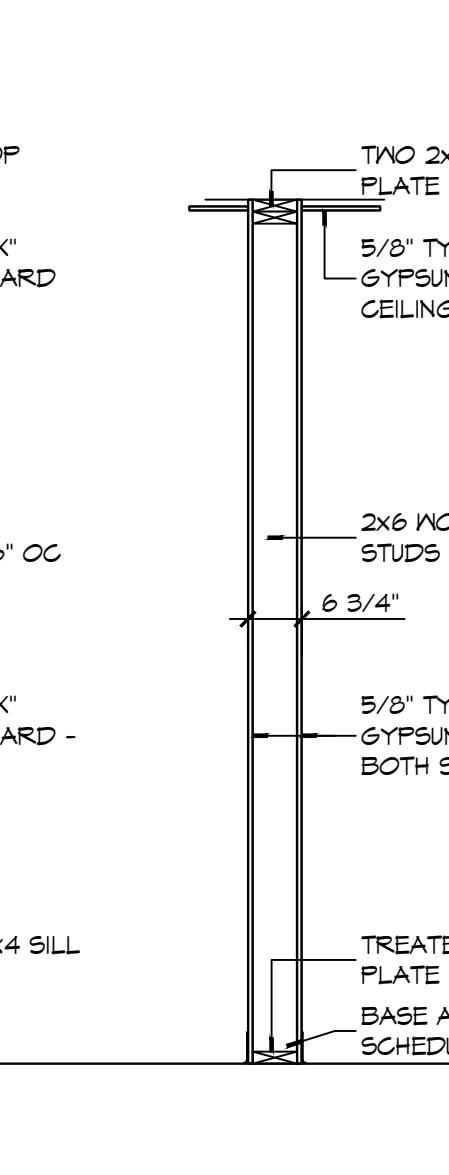

P8

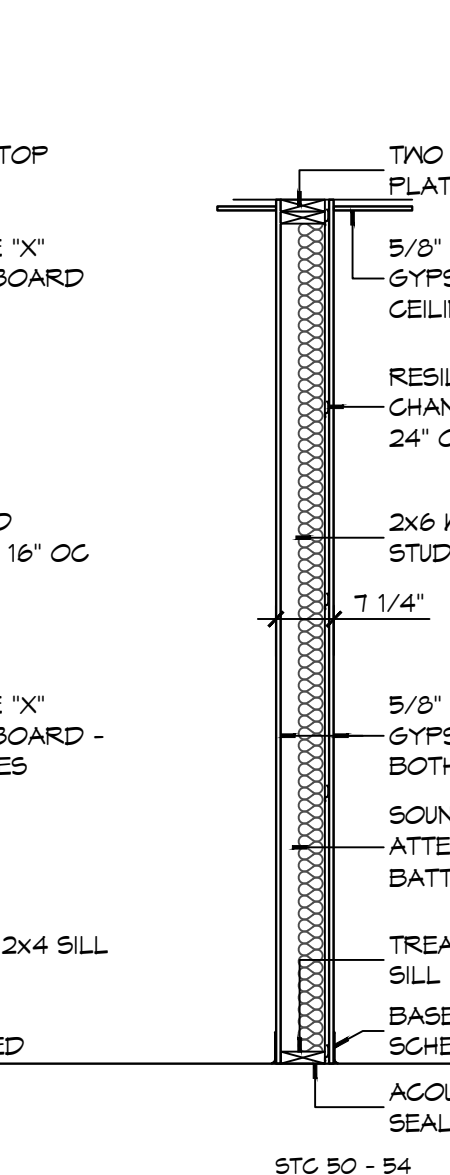

P9

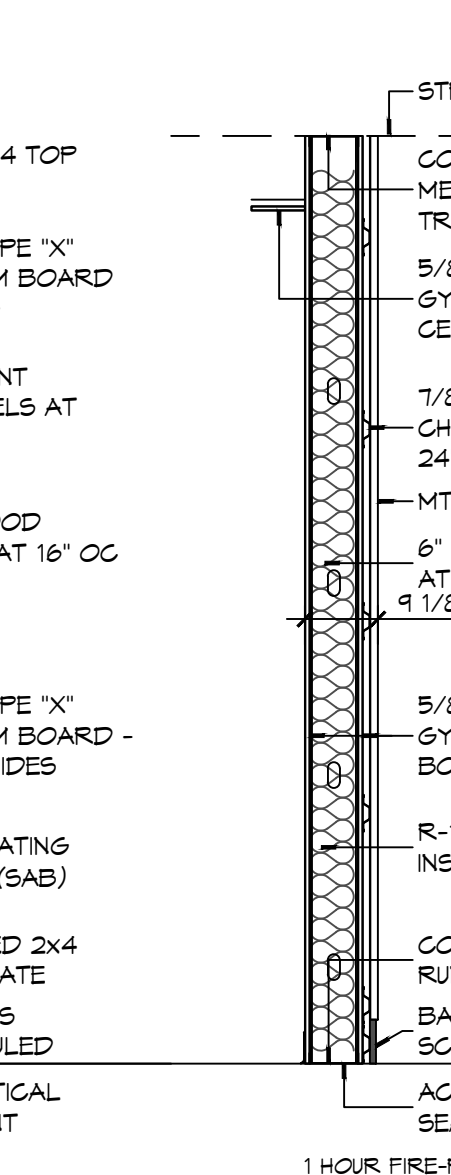

P10

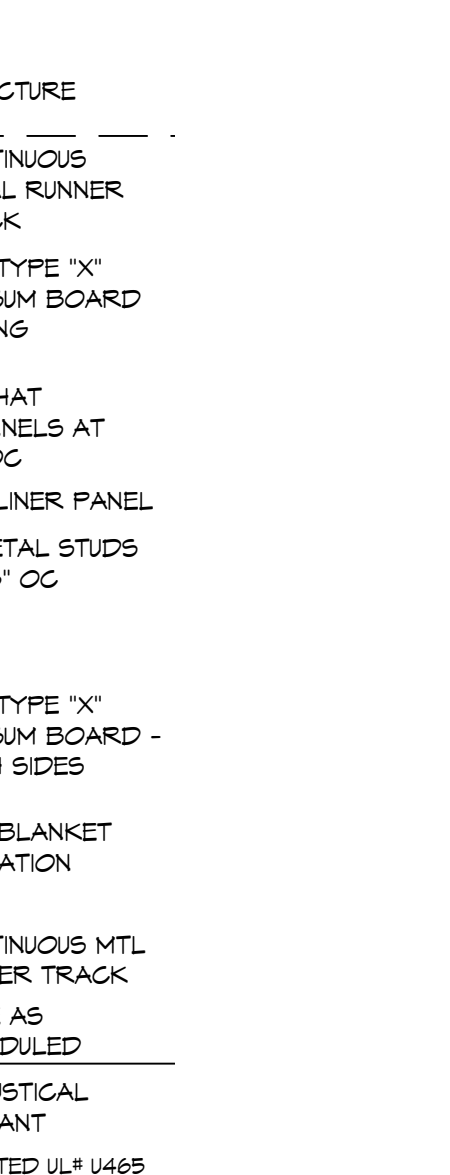

P11
1 HOUR FIRE-RATED ULF U465

1 PARTITION TYPES
SCALE: 1/2" = 1'-0"

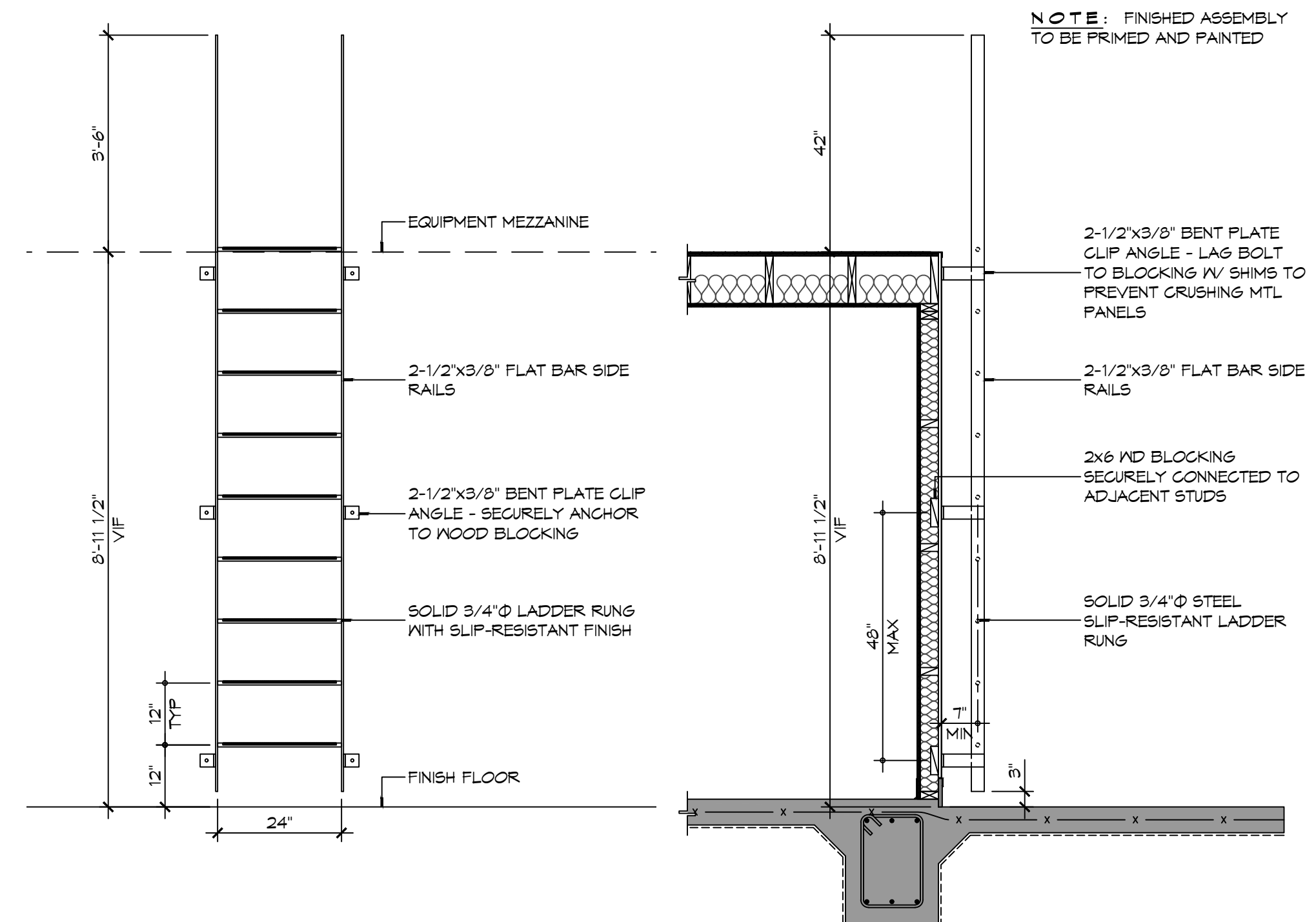

NOTE: FINISHED ASSEMBLY TO BE PRIMED AND PAINTED

PARTITION NOTES

1. THE "PARTITION TYPE TAG", ILLUSTRATED ON SHEET G001, INDICATES THE ASSEMBLY OF THE GENERAL EXTENTS OF EACH PARTITION INDICATED BY THE TAG ON THE FLOOR PLANS.
2. WHERE RATED PARTITIONS ARE INDICATED, REFER TO THE REFERENCED ASSEMBLY DIRECTORY FOR THE COMPLETE EXTENT OF THE ASSEMBLY CITED.
3. SEE LIFE SAFETY PLAN FOR LOCATIONS OF RATED PARTITIONS.
4. CONTRACTOR SHALL REPORT TO THE ARCHITECT ANY CONFLICTS BETWEEN THE INDICATED FIRE RATINGS OF THE PARTITION AND THAT INDICATED ON THE LIFE SAFETY PLAN. DO NOT PROCEED WITH CONSTRUCTION OF PARTITION UNTIL CONFLICT HAS BEEN RESOLVED TO THE SATISFACTION OF THE ARCHITECT.
5. UL DESIGN NUMBERS REFER TO THE UNDERWRITERS LABORATORIES FIRE RESISTANCE DIRECTORY - LATEST ADDITION.
6. ALL FIRE RATED ASSEMBLIES SHALL HAVE FIRESTOPS AT THE HEAD, SILL, THROUGH PENETRATIONS, OPENINGS, AND JUNCTURES WITH DISSIMILAR MATERIALS. SMOKE RESISTANT ASSEMBLIES SHALL BE SEALED AT SIMILAR CONDITIONS.
7. NON-RATED PARTITIONS SHALL HAVE SEALANTS AT THE HEAD, SILL, THROUGH PENETRATIONS, OPENINGS, AND JUNCTURES WITH DISSIMILAR MATERIALS.
8. EXTEND RATED PARTITIONS THROUGH THE INTERIOR FACE OF EXTERIOR WALL GYPSUM BOARD AND SEAL TO THE INSIDE FACE OF THE EXTERIOR WALL SHEATHING.
9. MAINTAIN THE FIRE-PROTECTION RATINGS FOR ALL OPENINGS AND PENETRATIONS IN RATED PARTITIONS.
10. REFER TO STRUCTURAL DRAWINGS FOR EXTENT AND DESCRIPTION OF INTERIOR STRUCTURAL WALLS NOT INDICATED AS SUCH ON FLOOR PLANS.
11. INSTALL BLOCKING OR BACKER MATERIAL FOR ATTACHMENT/MOUNTING FOR WALL HUNG ITEMS OR EQUIPMENT DESCRIBED IN DOCUMENTS.
12. UL AND SA (GYPSUM ASSOCIATION) TEST NUMBERS MAY VARY ON THE MANUFACTURER OR COMPONENTS ACTUALLY USED.
13. PROVIDE TYPE "X" GYPSUM BOARD UNLESS OTHERWISE NOTED.
14. PROVIDE WATER RESISTANT GYPSUM BOARD (WRGB) AT AREAS THAT ARE SCHEDULED TO RECEIVE CERAMIC TILE FINISH.
15. PROVIDE 5/8" CEMENTITIOUS BACKER BOARD (CBB) AT SHOWER AREAS AND OTHER WET AREAS THAT ARE INDICATED TO RECEIVE TILE IN THE INTERIOR ELEVATIONS.
16. INSTALLATION OF GYPSUM BOARD, BACKER BOARD, AND BASE BOARD SHALL CONFORM TO THE REQUIREMENTS FOR FIRE RATINGS AND ACOUSTICAL RATINGS.
17. ROOMS WITH SOUND ATTENUATING BLANKETS (SAB) ARE IDENTIFIED IN THE PARTITION TYPE DESCRIPTION. EXTEND SAB THE FULL LENGTH AND HEIGHT OF ALL ROOM PERIMETER PARTITIONS TO PROVIDE A COMPLETE ROOM ENCLOSURE.
 - a. NOTE THAT 3-1/2" FIBERGLASS BATTS OR 2" MINERAL WOOL FIBER MAY BE SUBSTITUTED FOR SOUND ATTENUATING BLANKETS.
18. LINE OF "STRUCTURE" AS SHOWN AT PARTITION TYPE HEAD CONDITIONS IS DIAGRAMMATIC ONLY AND DOES NOT INDICATE EXACT CONSTRUCTION CONDITIONS. OFFSET PARTITION CONSTRUCTION AS NECESSARY TO EXTEND WALL TO DECK ABOVE AND SEAL AS INDICATED.
19. WHERE PARTITIONS AND/OR FURRING MEET, MAINTAIN A FLUSH SURFACE ON THE SIDE WHERE THE FINISH IS STRAIGHT OR CONTINUOUS UNLESS NOTED OTHERWISE.
20. INDICATED STC RATING IS BASED UPON USG ACOUSTICAL ASSEMBLIES GUIDELINES.

STENCIL DETAIL

1 HR FIRE RATED WALL DO NOT PENETRATE

THE ABOVE WORDING SHALL BE LOCATED AT 10'-0" INTERVALS ABOVE CEILING ON FIRE PARTITIONS NO LESS THAN ONCE FOR EACH SPACE.

PROVIDE PAINTED STENCIL LETTERING IN RED PERMANENT PAINT ABOVE CEILING LINE INDICATING WALL RATINGS.

STATE FIRE RATING INDICATED ON LIFE SAFETY PLAN.

DAMMON ENGINEERING, INC.
LOUISIANA & MISSISSIPPI

Chief Engineer: Brian Misch, PE
554 Old Spanish Trail
Slidell, LA 70458
www.dammonengineering.com
info@dammonengineering.com
PH: 985.649.5832

#	DESCRIPTION	DATE

SEAL:

STENCIL DETAIL

**NEW FIRE STATION #10
ST. TAMMANY FIRE PROTECTION
DISTRICT NO. 1**

248 LAKESHORE VISTA BLVD
SLIDELL, LA 70461
JOB No: 2519 DATE: 12-05-2025
DRAWN BY: JMS CHECKED BY: CKD

SHEET TITLE:
PARTITION TYPES,
MISCELLANEOUS DETAILS

DRAWING NUMBER:
A501

SHEET No: 27 of 37

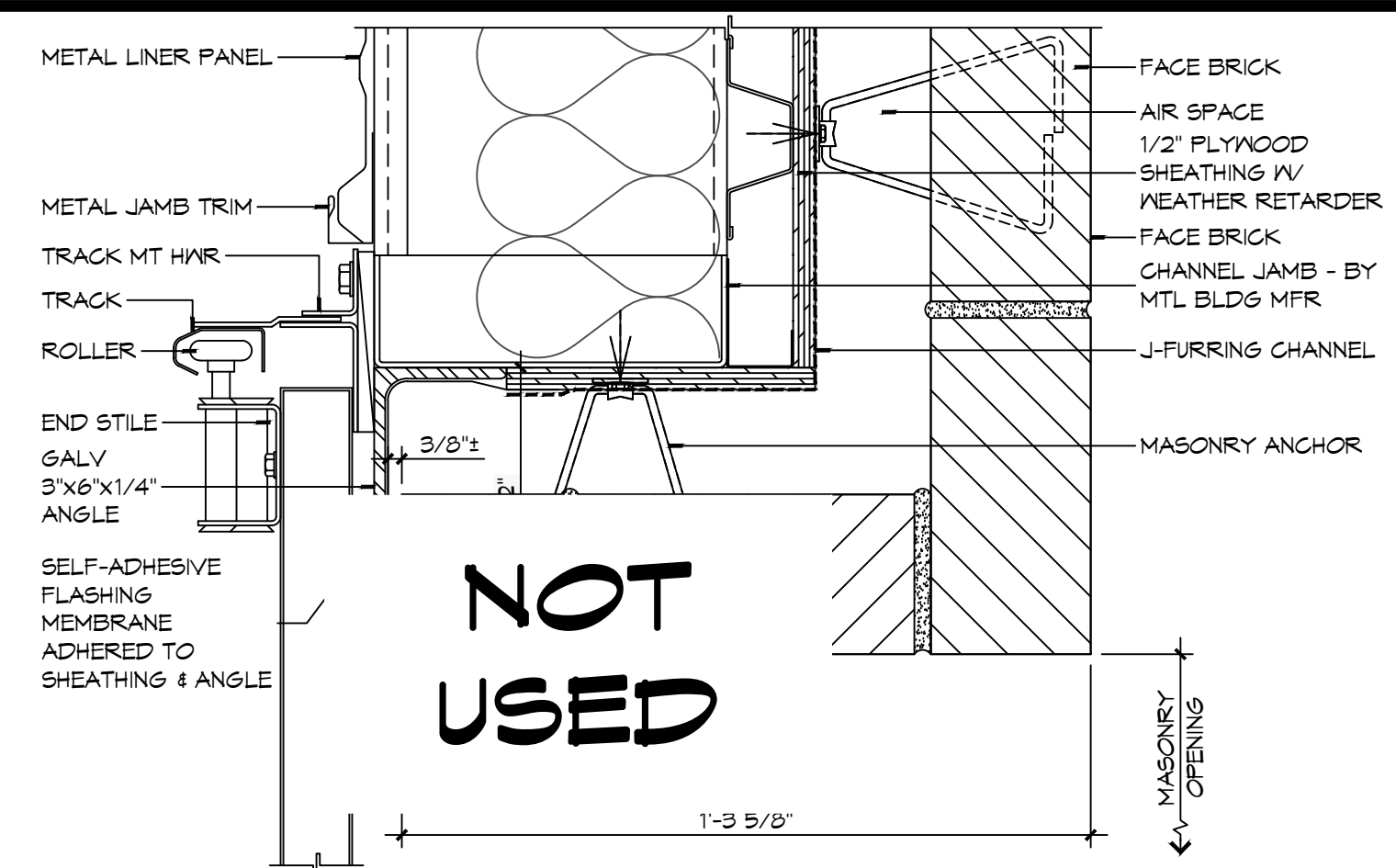
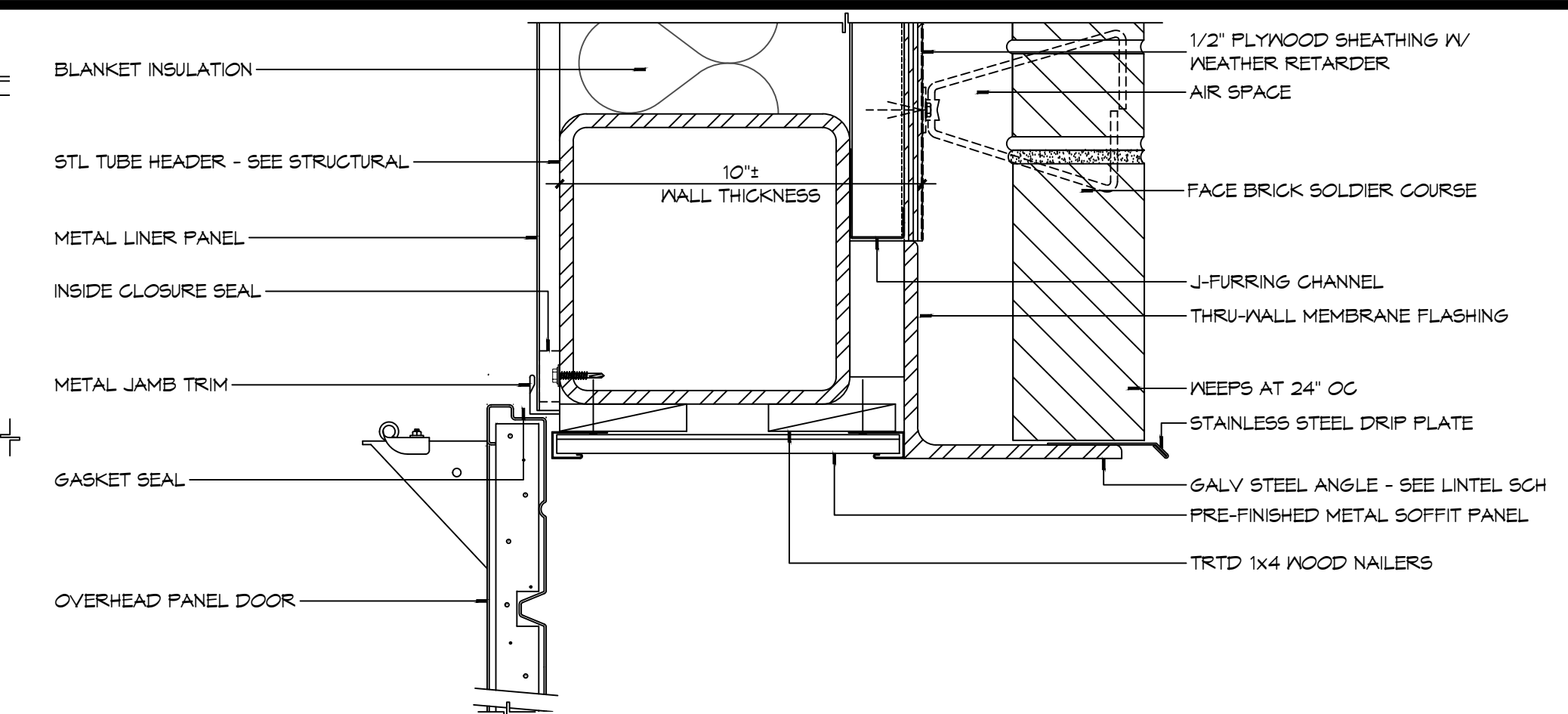
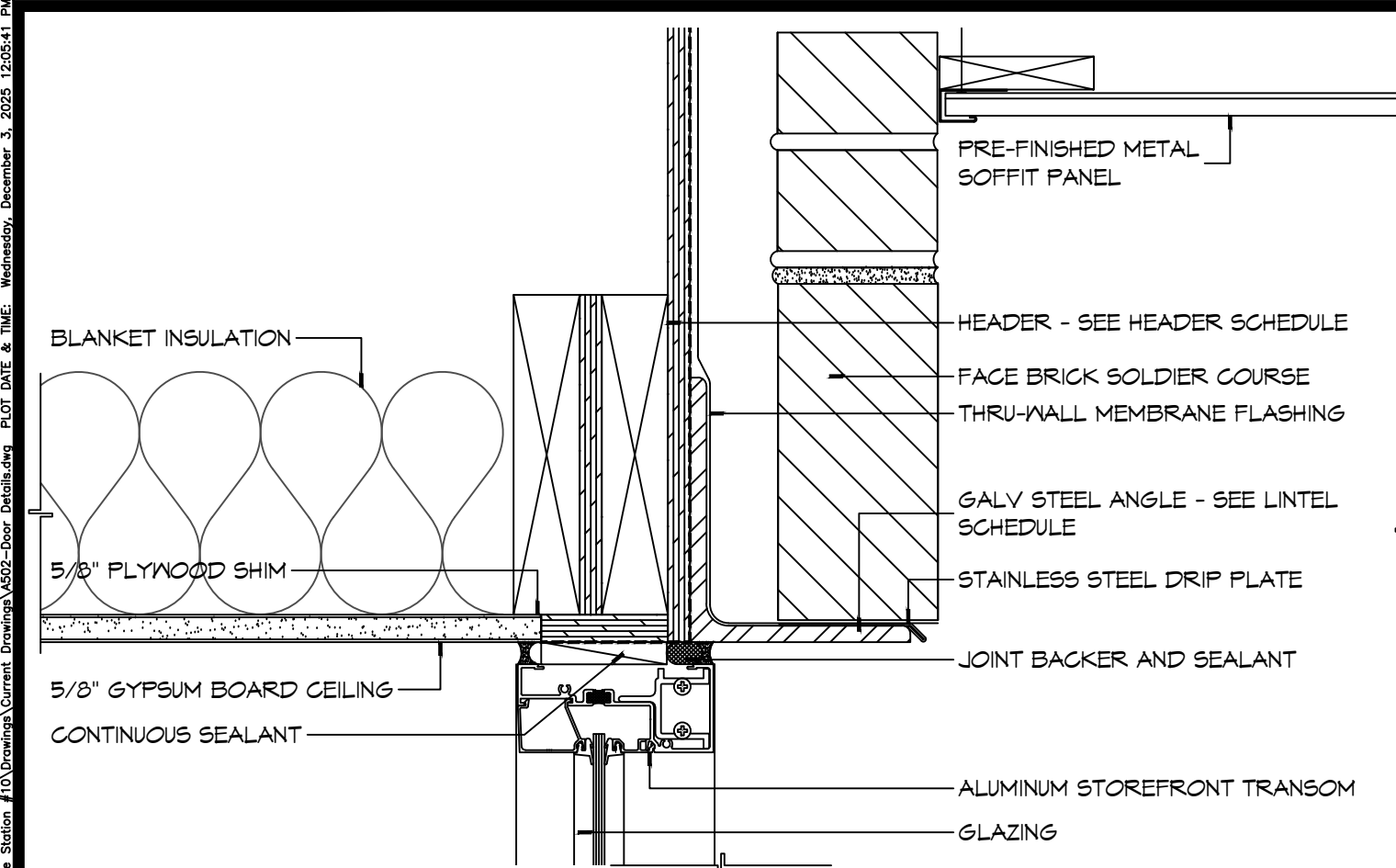

- ### DOOR AND FRAME NOTES
- HOLLOW METAL FRAME DIMENSIONS INDICATED IN THE DETAILS ARE NOMINAL. MANUFACTURER'S STANDARD WIDTH FRAME, WITH THROAT OPENING APPROPRIATE TO WALL TYPE MAY BE PROPOSED IN SHOP DRAWINGS, IF NO OTHER MODIFICATIONS OF THE DETAIL IS REQUIRED.
 - PROVIDE WOOD BLOCKING OR FLAT STRAP BEHIND GYPSUM BOARD IN WALL BEHIND DOORS SCHEDULED TO HAVE WALL MOUNTED DOOR STOPS. REFER TO HARDWARE SCHEDULE.
 - "WALL THICKNESS" DIMENSIONS INDICATED MAY BE TYPICAL. REFER TO PARTITION TYPES FOR PARTITION THICKNESS WHERE OPENING IS LOCATED.
 - WHERE A DOOR IS LOCATED NEAR CORNER OF ROOM AND IT IS NOT LOCATED BY DIMENSION ON PLAN OR DETAILS, DIMENSION SHALL BE 4 INCHES FROM FINISH FACE OF WALL TO FRAME OPENING.
 - WHERE A DOOR IS LOCATED BY DIMENSION, THE DIMENSION IS TAKEN FROM THE CENTERLINE OF THE FRAME OPENING UNLESS NOTED OTHERWISE.
 - THRESHOLDS, WHEN REQUIRED, ARE TO BE NOTED IN THE DOOR HARDWARE SCHEDULE.
 - WHERE MORE THAN ONE WALL FINISH IS INDICATED REFER TO FINISH SCHEDULE FOR WALL FINISH ON A PARTICULAR SIDE OF WALL.

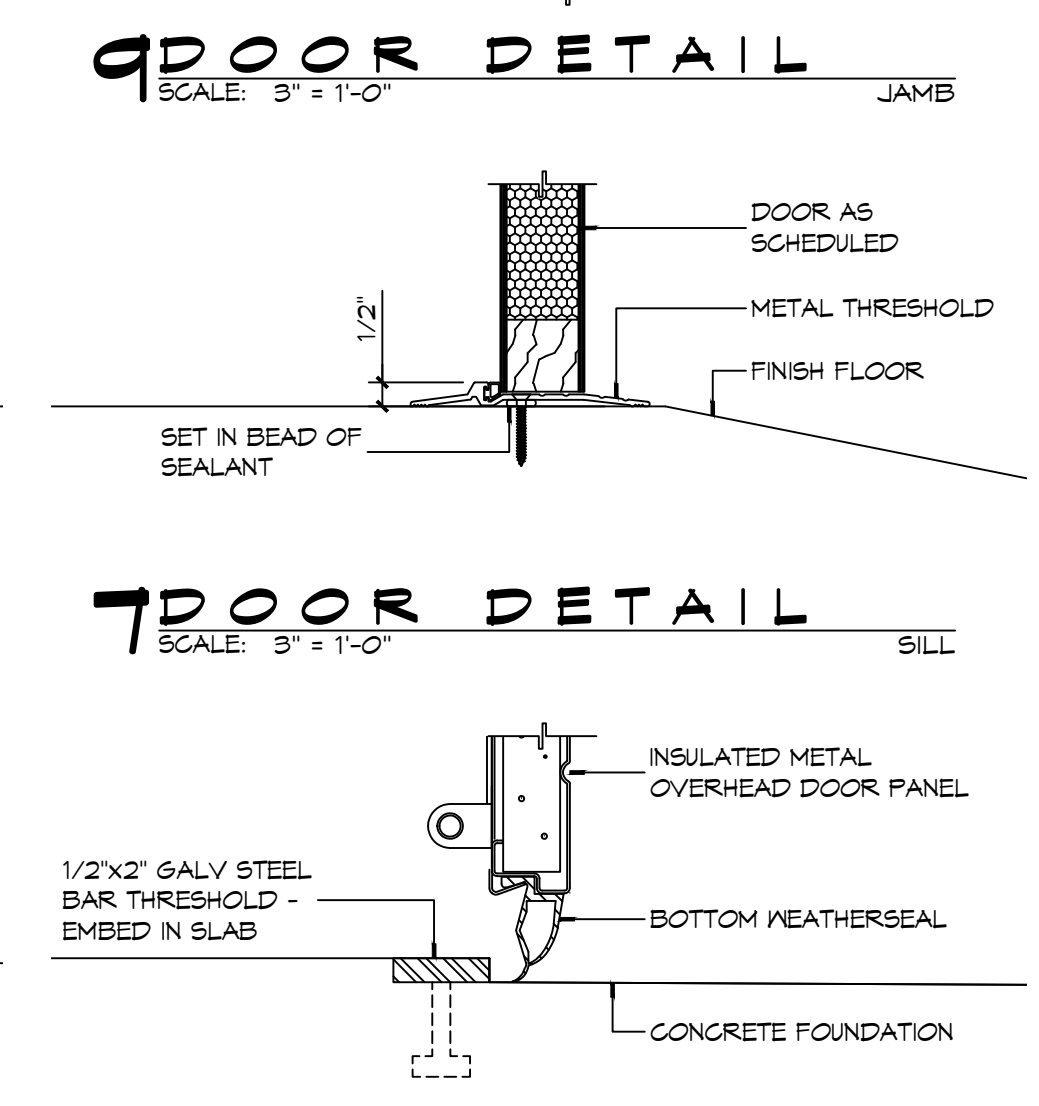
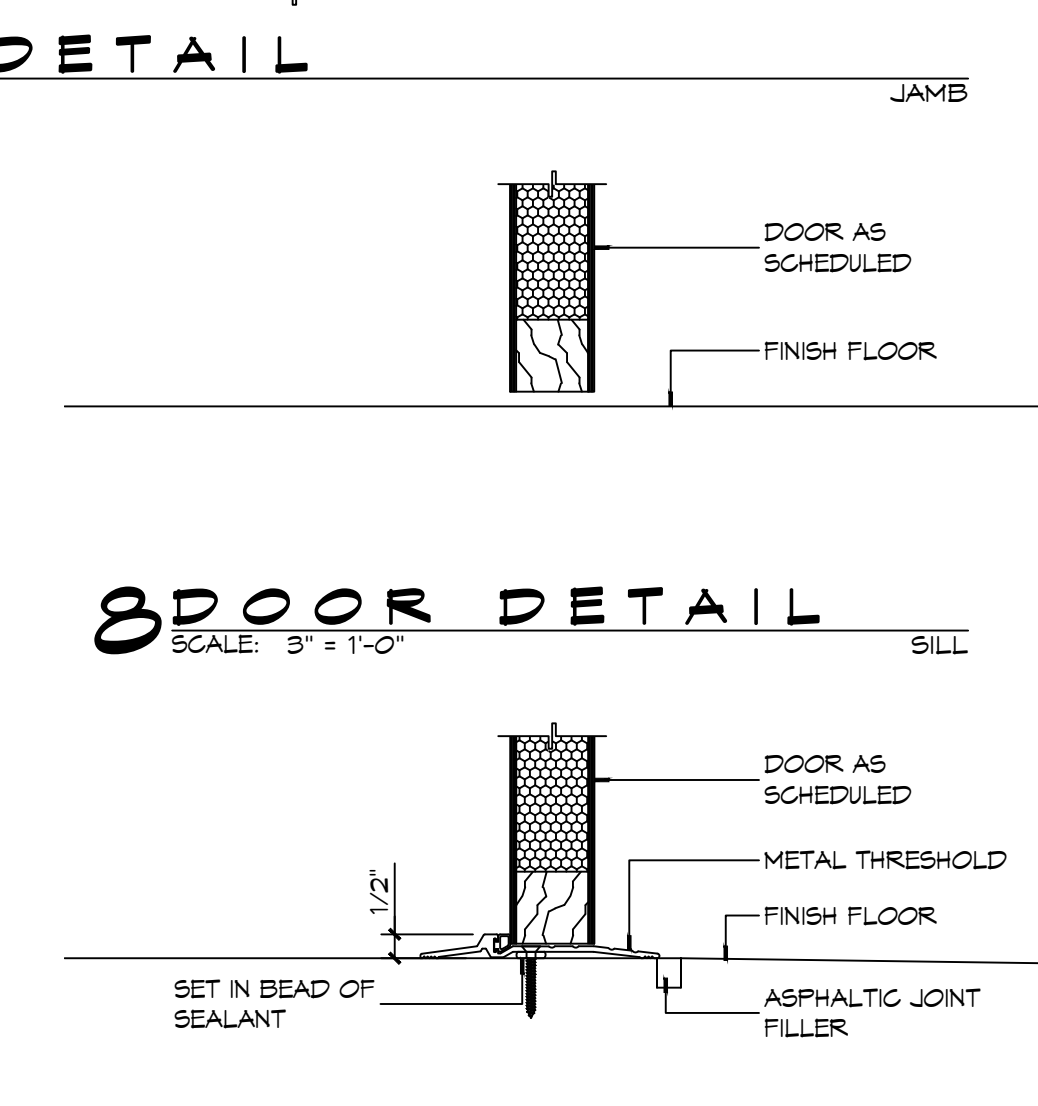
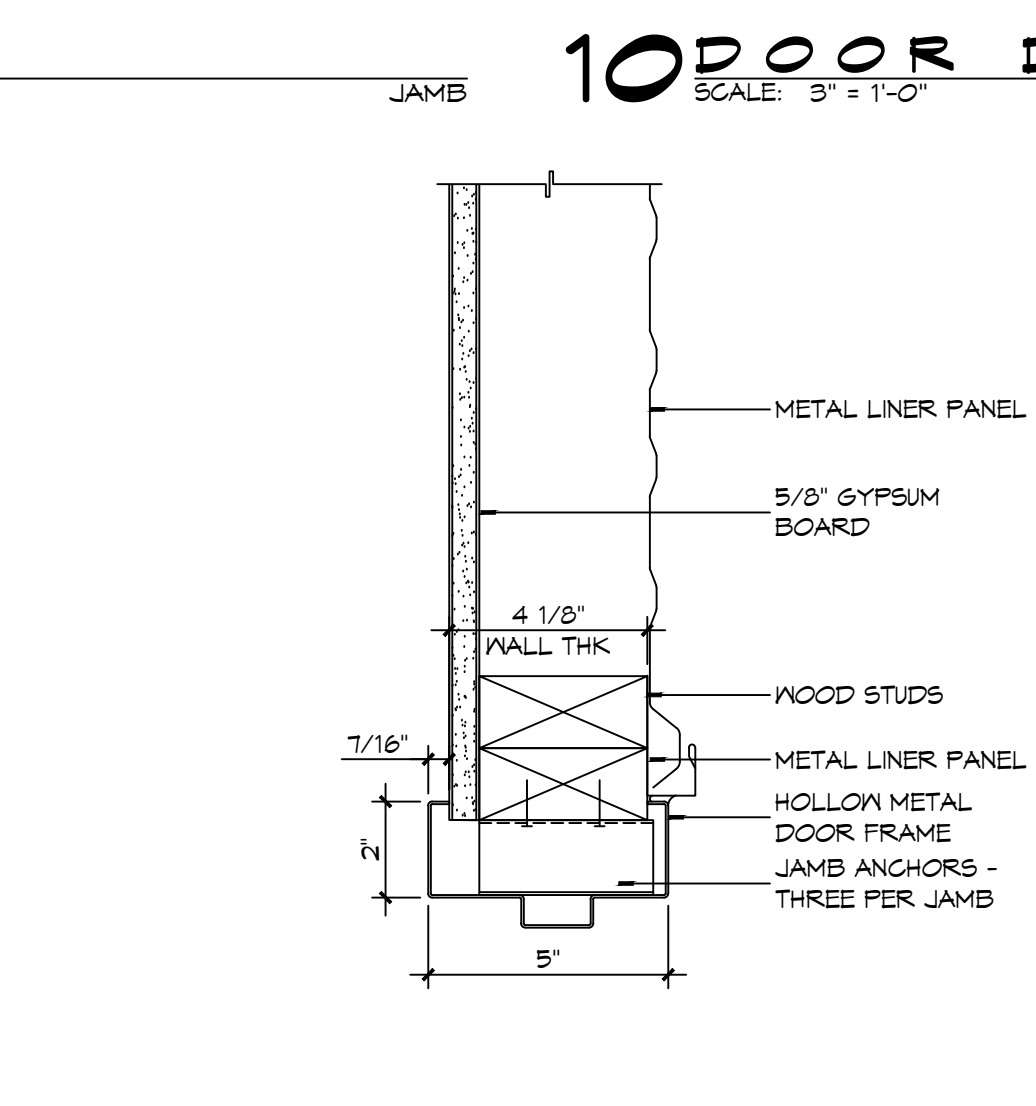
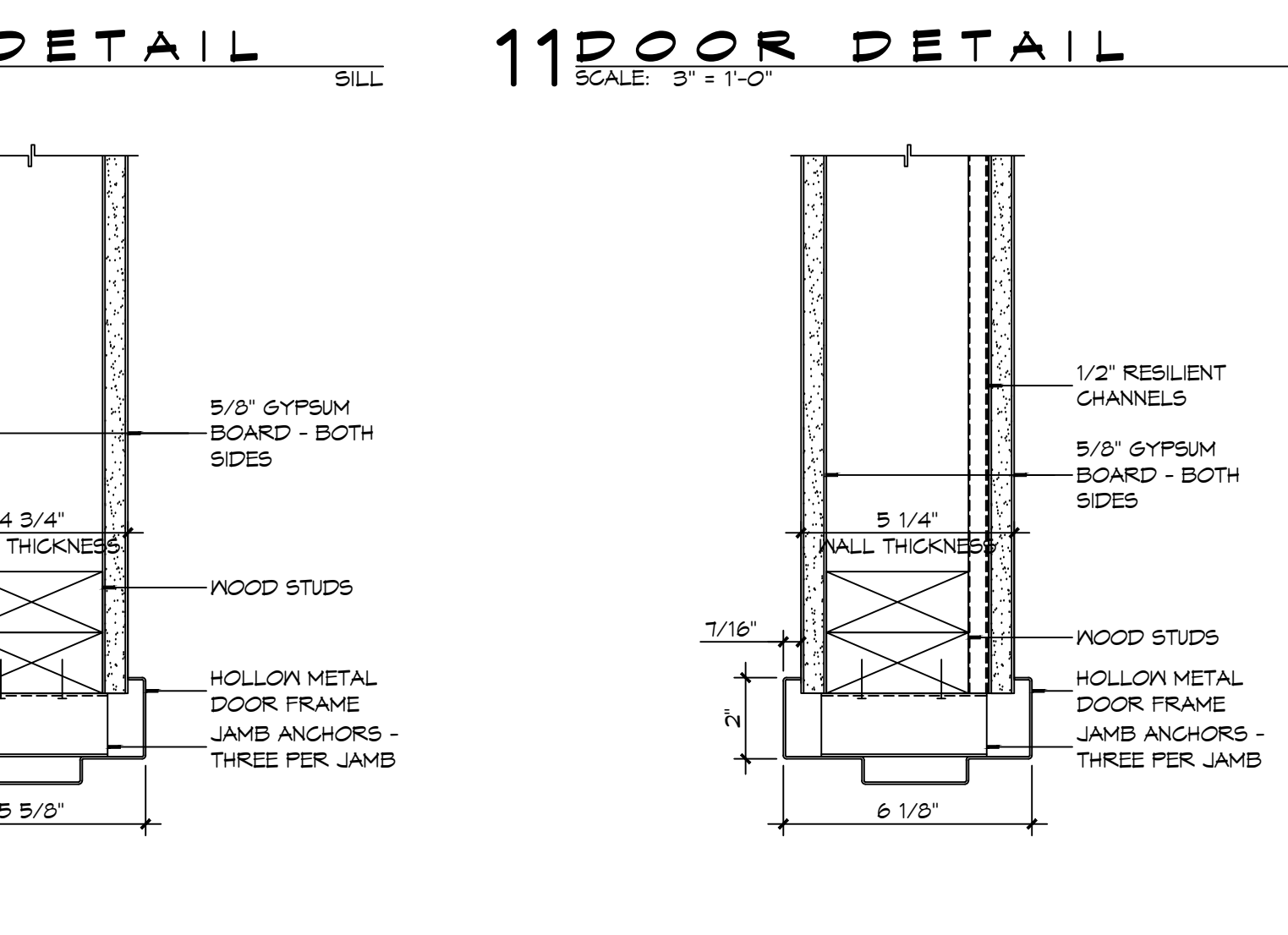
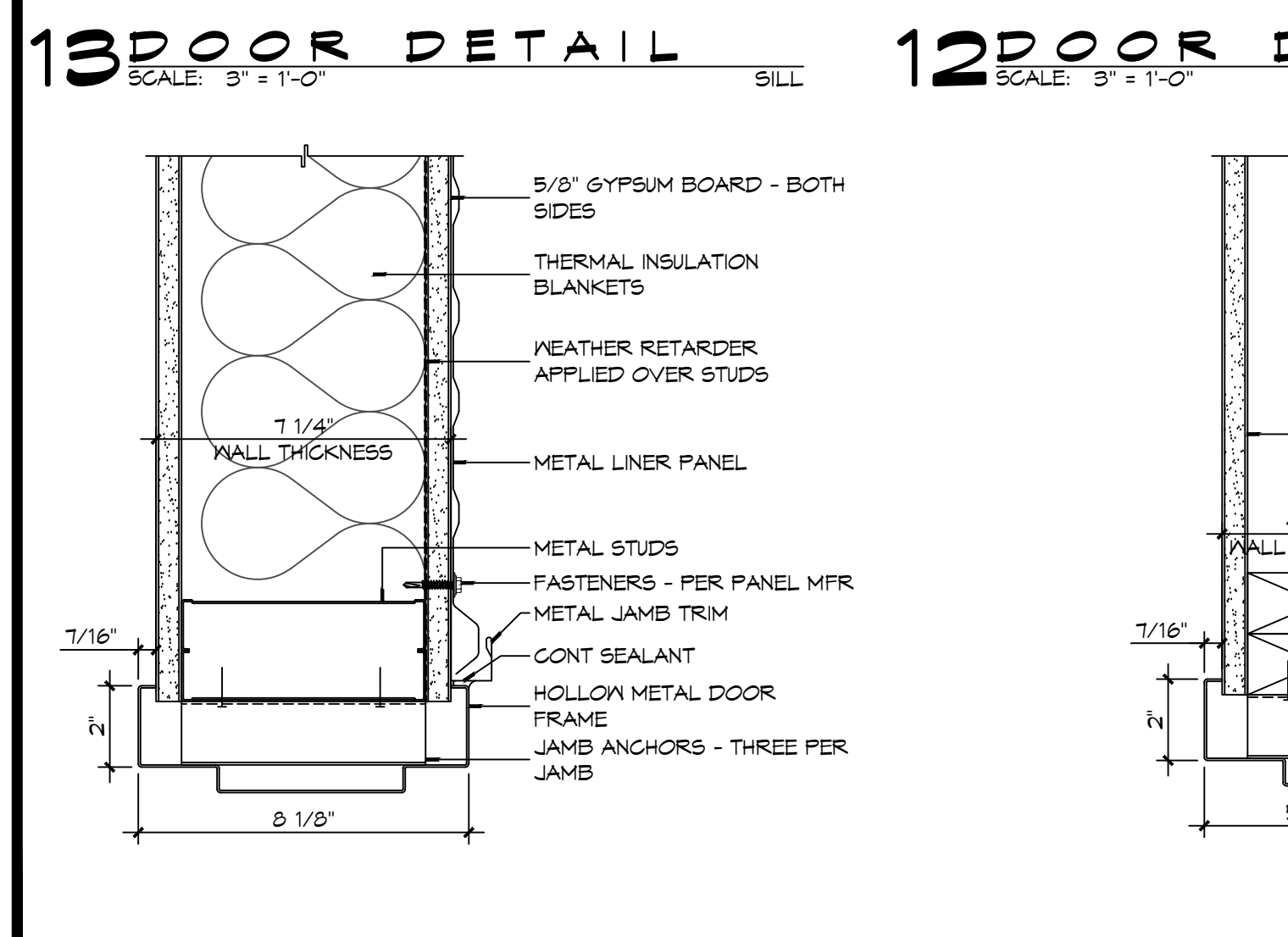
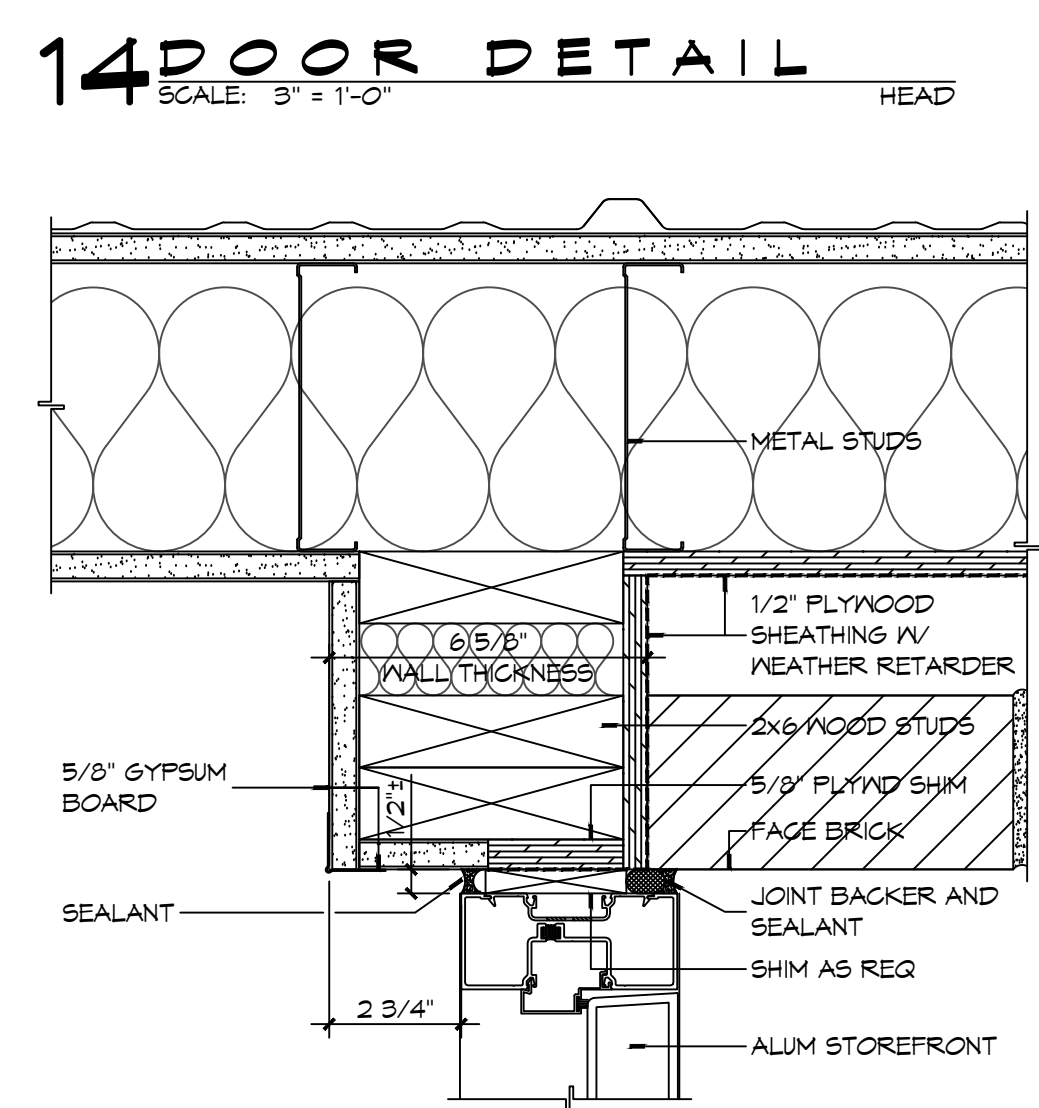
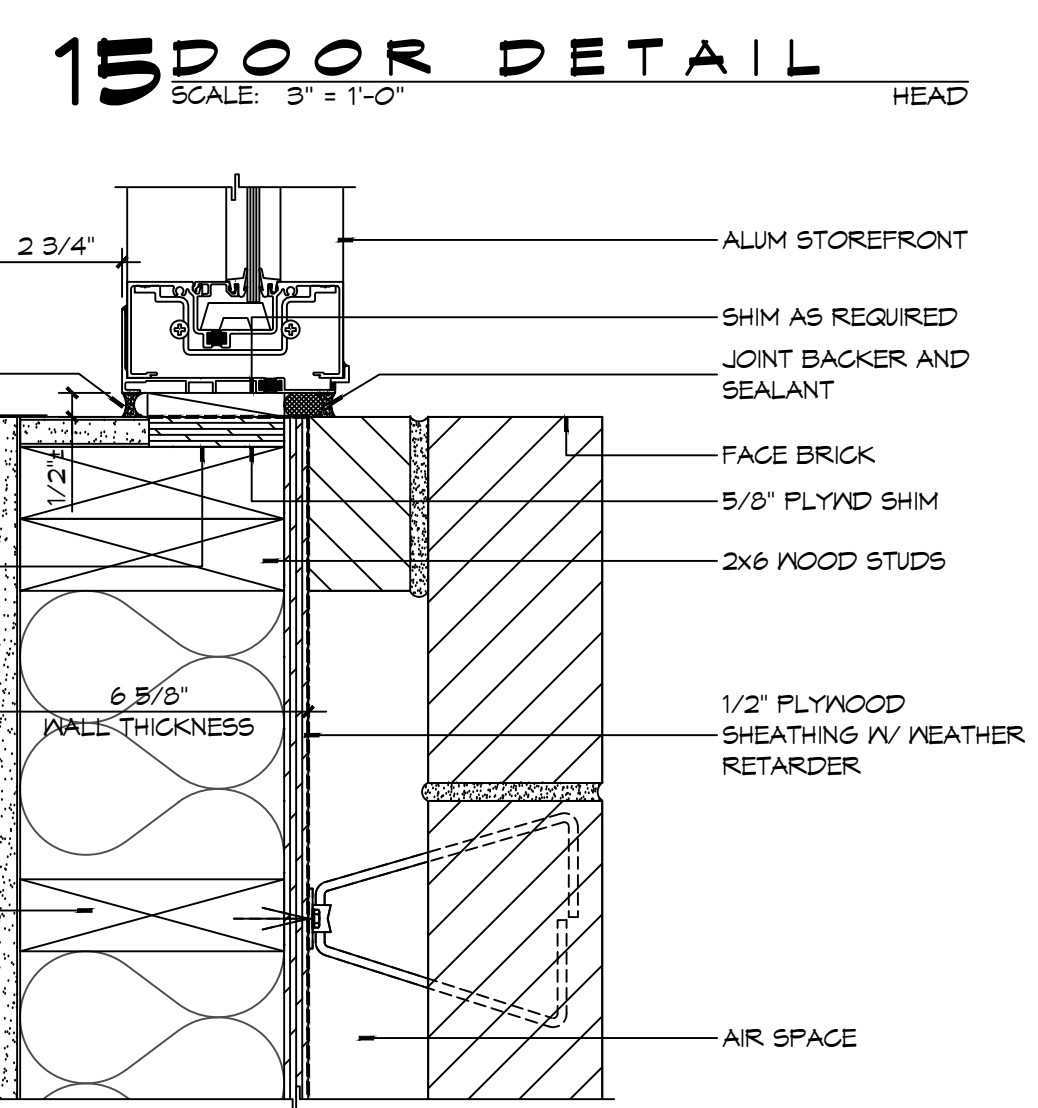
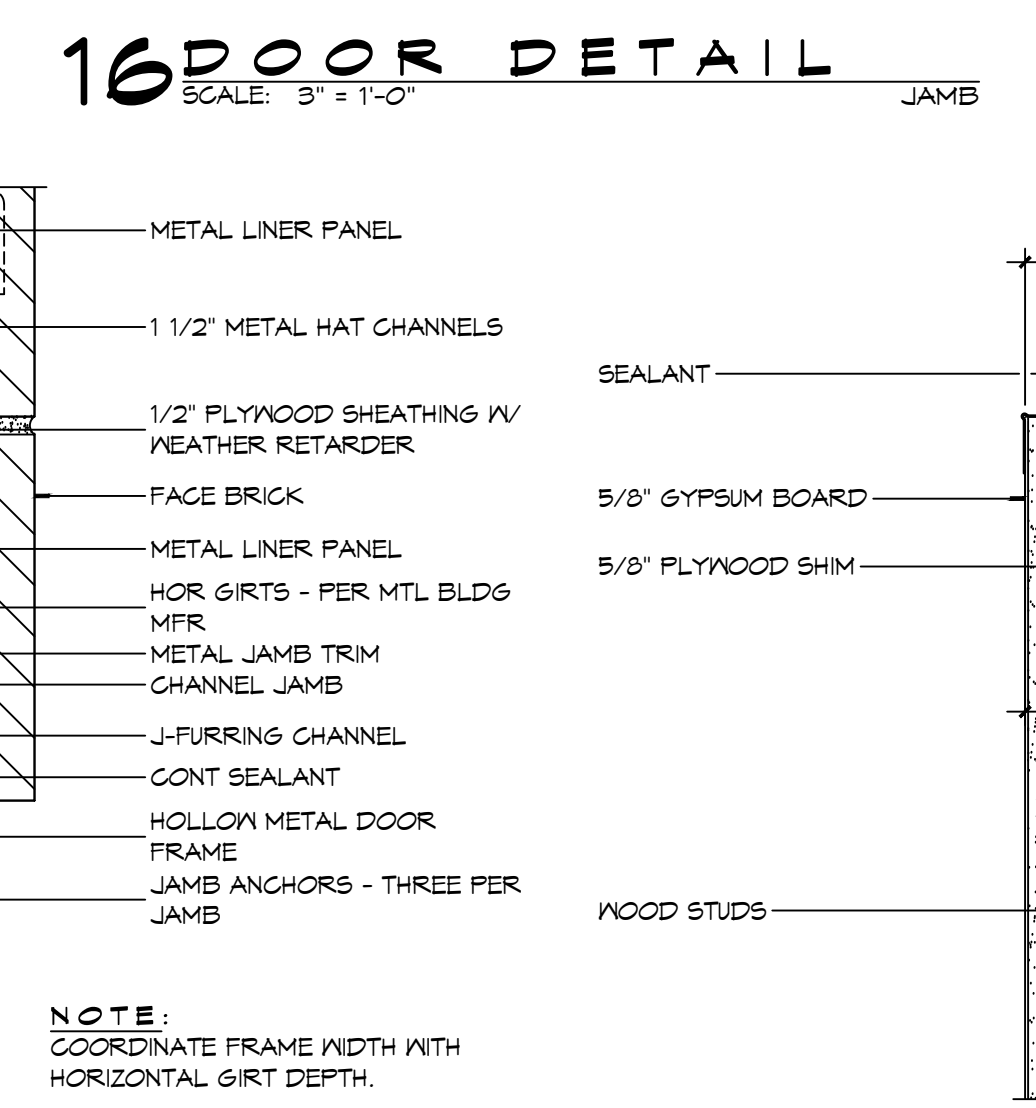
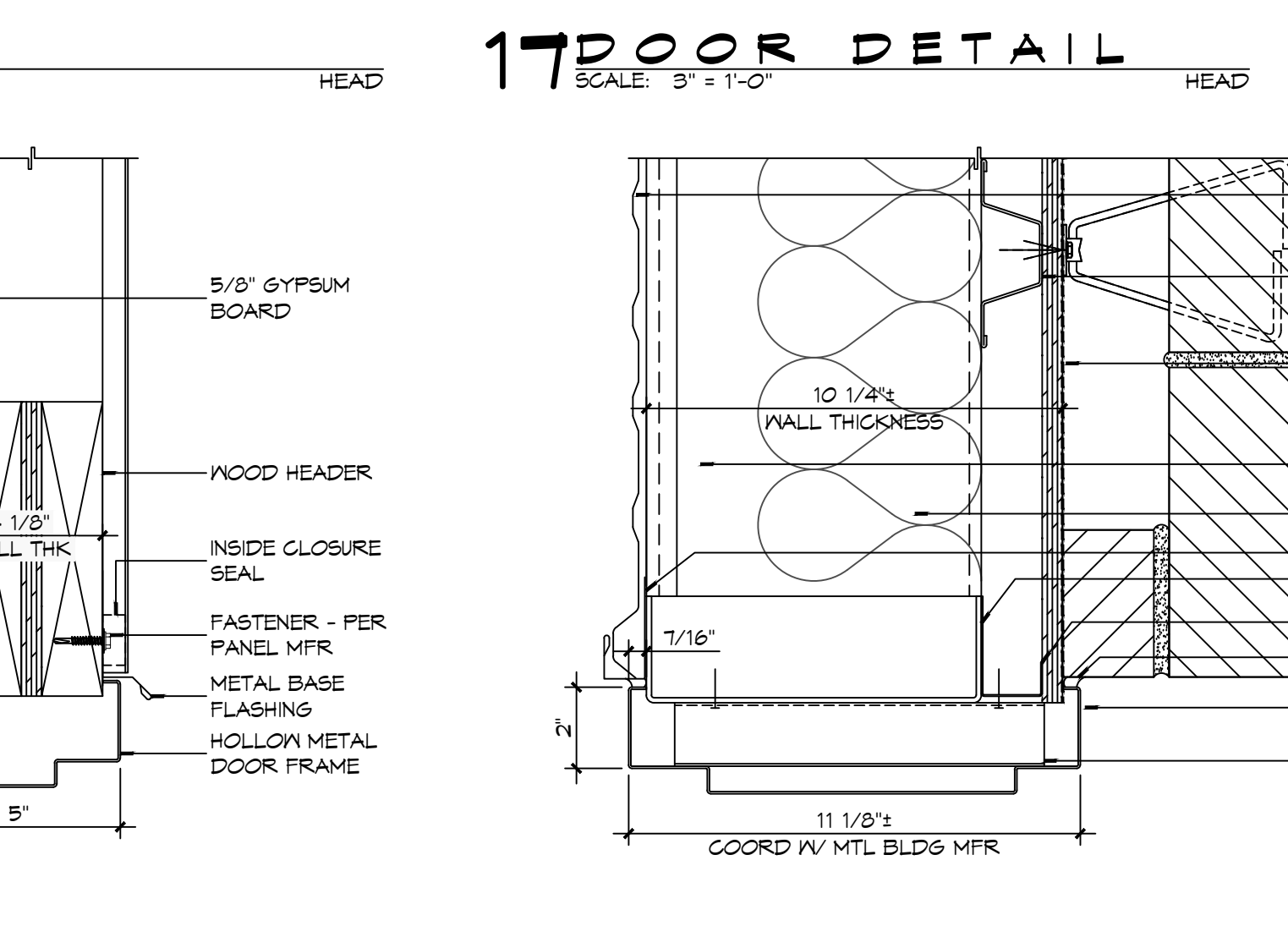
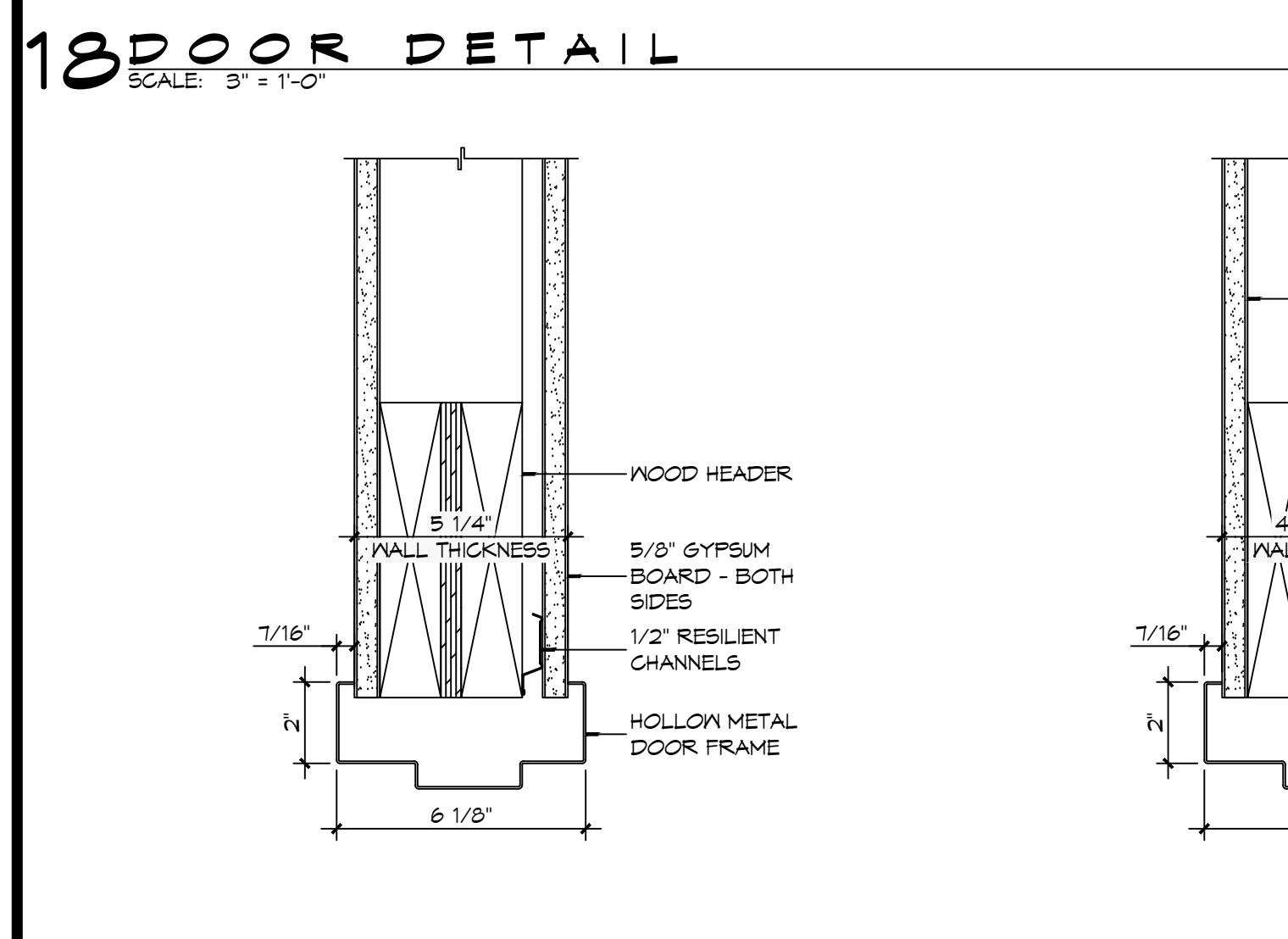
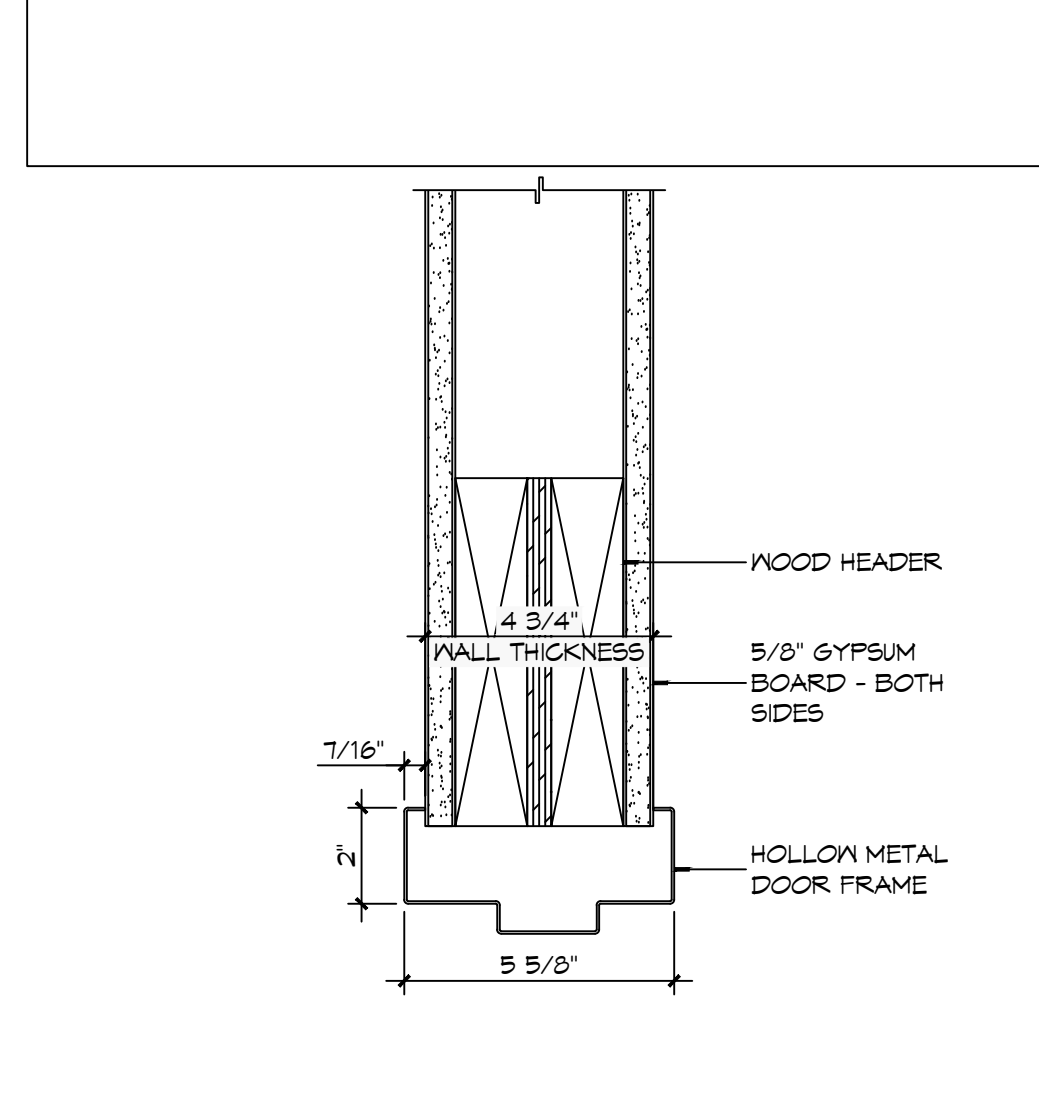
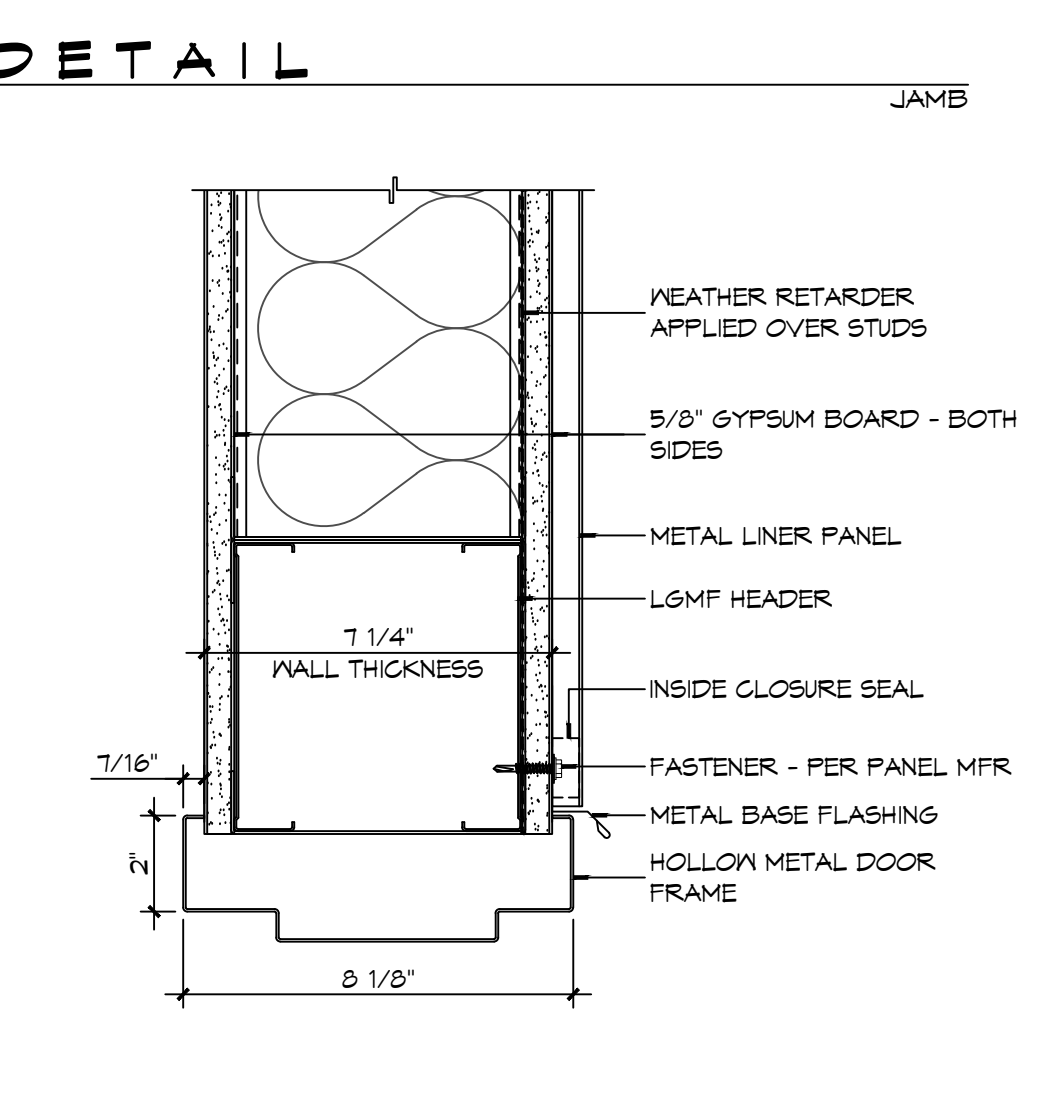
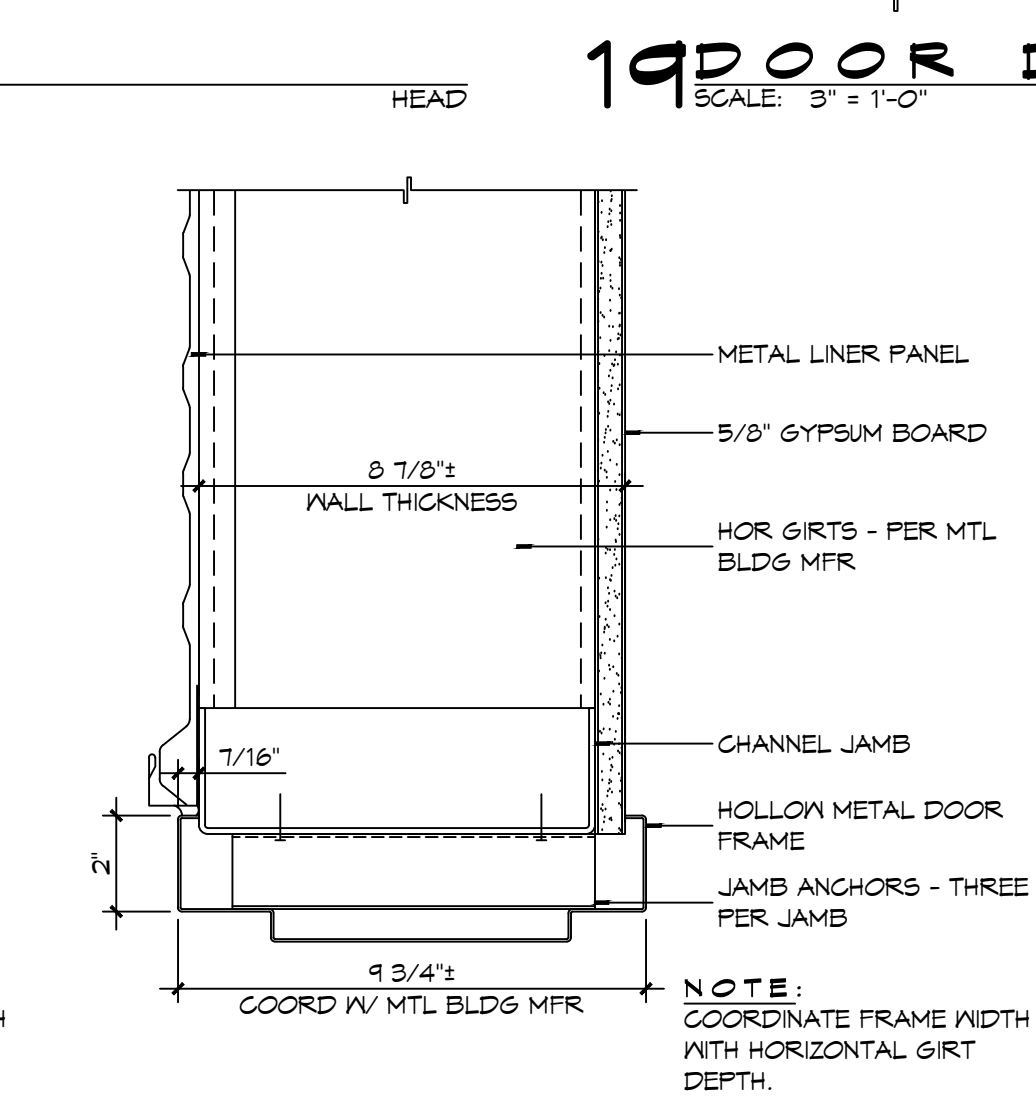
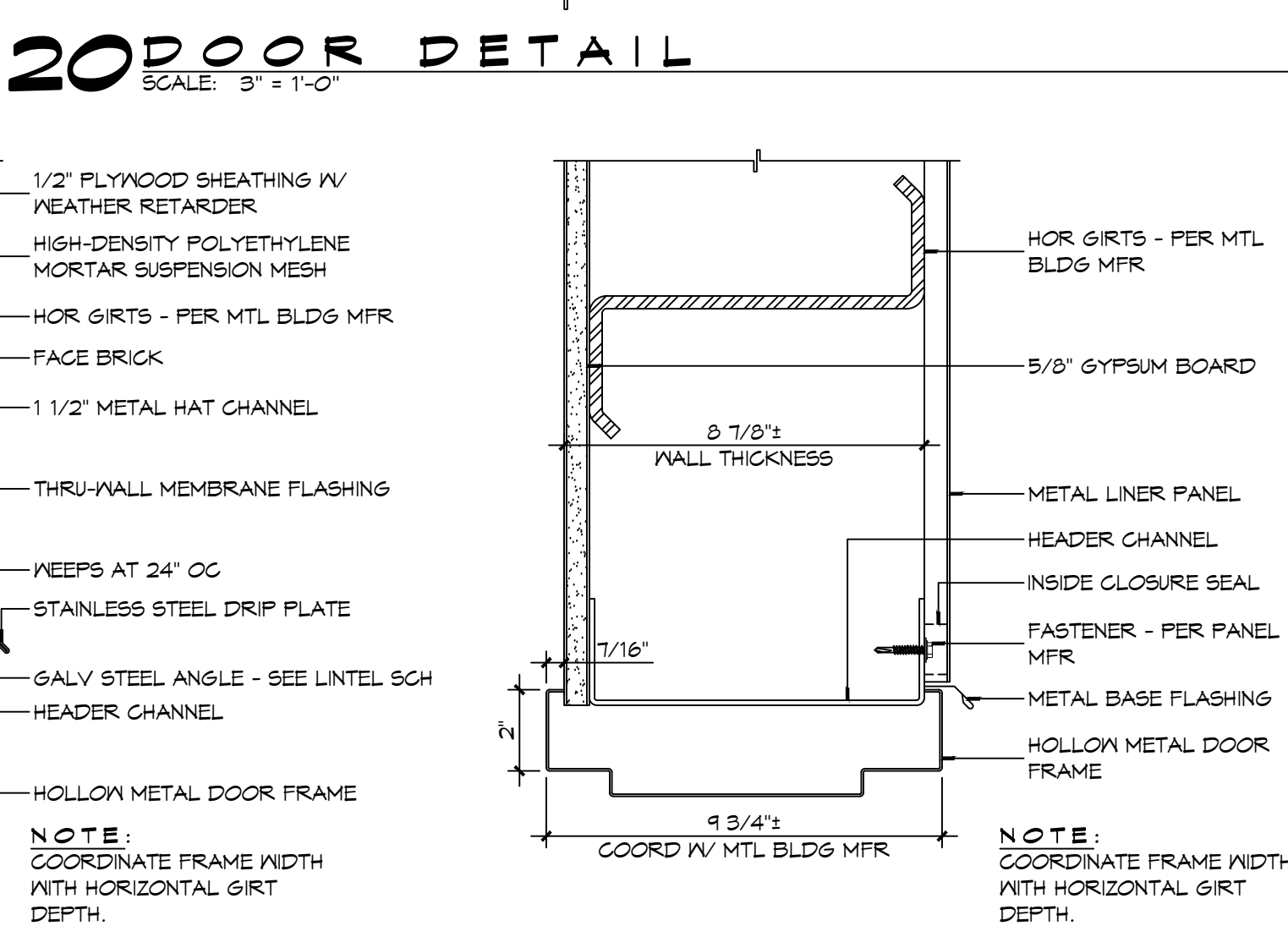
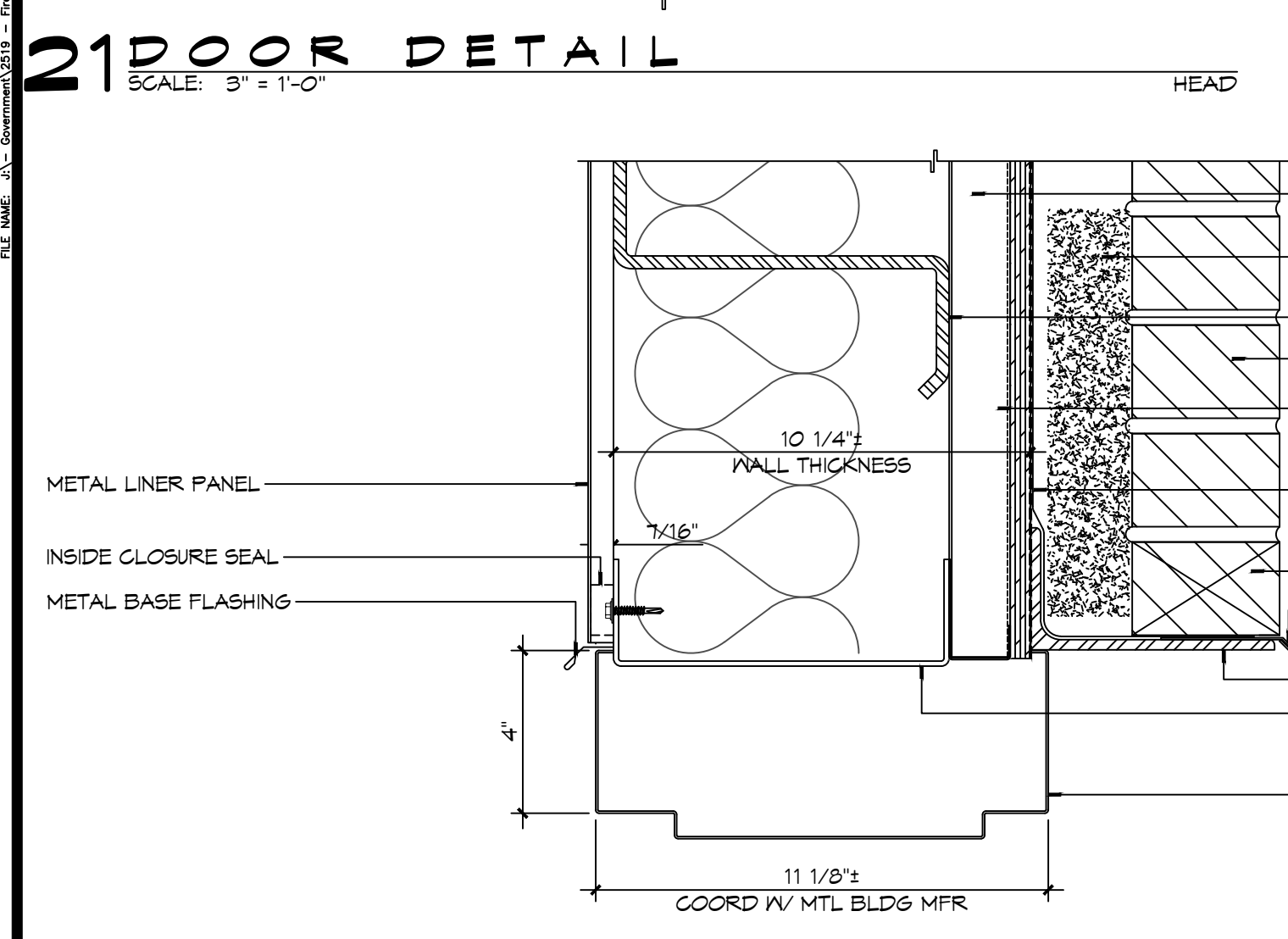

DAMMON
ENGINEERING, INC.
LOUISIANA & MISSISSIPPI
Chief Engineer: Brian Missett, PE
554 Old Spanish Trail
Slidell, LA 70458
www.dammonengineering.com
info@dammonengineering.com
PH: 985-649-5832

#	DESCRIPTION	DATE

SEAL: _____

NEW FIRE STATION #10
ST. TAMMANY FIRE PROTECTION DISTRICT NO. 1

246 LAKESHORE VISTA BLVD
SLIDELL, LA 70461
JOB No: 2519
DATE: 12-05-2025
DRAWN BY: CKD
CHECKED BY: JMS

SHEET TITLE:
DOOR DETAILS
DRAWING NUMBER:
A502
SHEET No: 26 of 37

DOOR SCHEDULE

MK	WIDTH	HEIGHT	TYPE	THICK	DOOR MATERIAL	FRAME MATERIAL	FRAME TYPE	HEAD	JAMB	SILL	FR	HWR	REMARKS
101A	3'-0"	7'-0"	FG	1 3/4"	ALUM	ALUM	F4	21/A502	9/A502 & 10/A502	7/A502	NR	01	
101B	3'-0"	7'-0"	F	1 3/4"	INSUL MTL	HM	F1	15/A502	6/A502	1/A502	45 MIN	07	
102A	3'-0"	7'-0"	GG	1 3/4"	ALUM	ALUM	F3	21/A502	10/A502	7/A502	NR	01	
103A	3'-0"	7'-0"	F	1 3/4"	SC WOOD	HM	F2	13/A502	4/A502	8/A502	20 MIN	02	SMOKE TIGHT
104A	3'-0"	7'-0"	F	1 3/4"	SC WOOD	HM	F2	14/A502	5/A502	8/A502	NR	03	
105A	(2) 2'-0"	7'-0"	LL	1 3/4"	SC WOOD	HM	F2	14/A502	5/A502	8/A502	NR	06A	
107A	3'-0"	7'-0"	F	1 3/4"	SC WOOD	HM	F2	13/A502	4/A502	8/A502	20 MIN	02	SMOKE TIGHT
109A	(2) 1'-6"	7'-0"	LL	1 3/4"	SC WOOD	HM	F2	14/A502	5/A502	8/A502	NR	06	
109B	(2) 1'-6"	7'-0"	LL	1 3/4"	SC WOOD	HM	F2	14/A502	5/A502	8/A502	NR	06	
109C	(2) 1'-6"	7'-0"	LL	1 3/4"	SC WOOD	HM	F2	14/A502	5/A502	8/A502	NR	06	
113A	3'-0"	7'-0"	F	1 3/4"	SC WOOD	HM	F2	13/A502	4/A502	8/A502	20 MIN	05	SMOKE TIGHT
114A	3'-0"	7'-0"	F	1 3/4"	SC WOOD	HM	F2	14/A502	5/A502	8/A502	NR	04	
116A	2'-4"	7'-0"	F	1 3/4"	SC WOOD	HM	F2	14/A502	5/A502	8/A502	NR	13	
117A	14'-0"	14'-0"	O2	1 1/2"	INSUL MTL	MTL	N/A	20/A502	19/A502	1/A502	NR	01	SEE DOOR NOTES NO. 1
117B	14'-0"	14'-0"	O2	1 1/2"	INSUL MTL	MTL	N/A	20/A502	19/A502	1/A502	NR	01	SEE DOOR NOTES NO. 1
117C	12'-0"	14'-0"	O2	1 1/2"	INSUL MTL	MTL	N/A	20/A502	19/A502	1/A502	NR	01	SEE DOOR NOTES NO. 1
117D	3'-0"	7'-0"	F	1 3/4"	INSUL MTL	HM	F2	18/A502	11/A502	2/A502	NR	12	
118A	3'-0"	7'-0"	L	1 3/4"	METAL	HM	F2	12/A502	3//A502	7/A502	NR	08	
119A	3'-0"	7'-0"	L	1 3/4"	METAL	HM	F2	12/A502	3//A502	7/A502	NR	09	
120A	3'-0"	7'-0"	L	1 3/4"	METAL	HM	F2	12/A502	3//A502	7/A502	NR	09	
121A	14'-0"	14'-0"	O2	1 1/2"	INSUL MTL	MTL	N/A	20/A502	19/A502	1/A502	NR	01	SEE DOOR NOTES NO. 1
121B	14'-0"	14'-0"	O2	1 1/2"	INSUL MTL	MTL	N/A	20/A502	19/A502	1/A502	NR	01	SEE DOOR NOTES NO. 1
122A	3'-0"	7'-0"	L	1 3/4"	MTL	HM	F2	17/A502	16/A502	7/A502	NR	09	
123A	3'-0"	7'-0"	L	1 3/4"	MTL	HM	F2	17/A502	16/A502	7/A502	NR	09	
124A	-	-	-	-	-	-	-	-	-	-	-	-	NOT USED
124B	8'-0"	7'-0"	O1	1 1/2"	MTL	MTL	N/A	20/A502	19/A502	1/A502	NR	01	MANUAL OPERATION

WINDOW SCHEDULE

MK	SIZE (WxH)	FRAME	TYPE	GLAZING	REMARKS
A	3'-0"x4'-0"	ALUM	SINGLE HUNG	IMPACT	BLACK FRAME
B	3'-2"x4'-0"	ALUM	FIXED	IMPACT	BLACK FRAME
C	3'-0"x4'-0"	ALUM	SINGLE HUNG	IMPACT	BLACK FRAME
D	3'-0"x4'-0"	ALUM	SINGLE HUNG	IMPACT	OBSOLETE/TRANSLUCENT GLASS IV/BLACK FRAME
E	3'-0"x5'-6"	ALUM	SINGLE HUNG	IMPACT	BLACK FRAME

NOTE: ALL EXTERIOR WINDOWS AND DOOR ASSEMBLES TO BE RATED FOR 140 MPH WINDS AND SHALL BE MISSILE IMPACT RESISTANT.

NOTE: DOORS IN A REQUIRED MEANS OF EGRESS SERVING ANY ASSEMBLY AREA HAVING AN OCCUPANT LOAD OF 50 OR MORE PERSONS SHALL NOT BE EQUIPPED WITH A LATCH OR LOCK OTHER THAN PANIC HARDWARE OR FIRE EXIT HARDWARE.

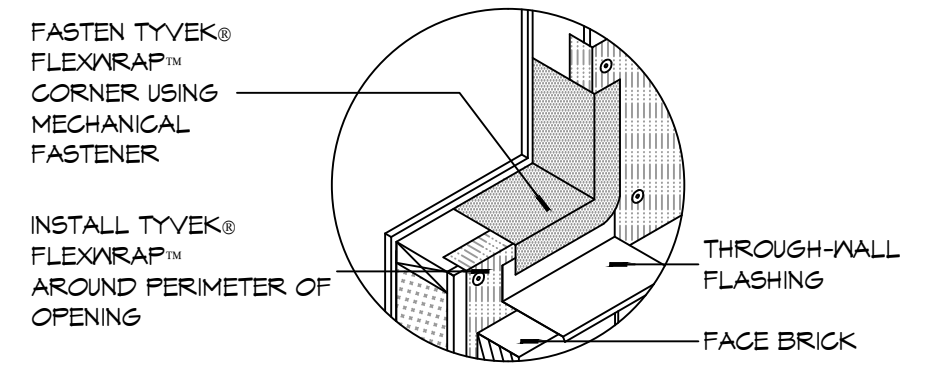

10 DETAIL
SCALE: NTS
TYPICAL WINDOW SILL FLASHING

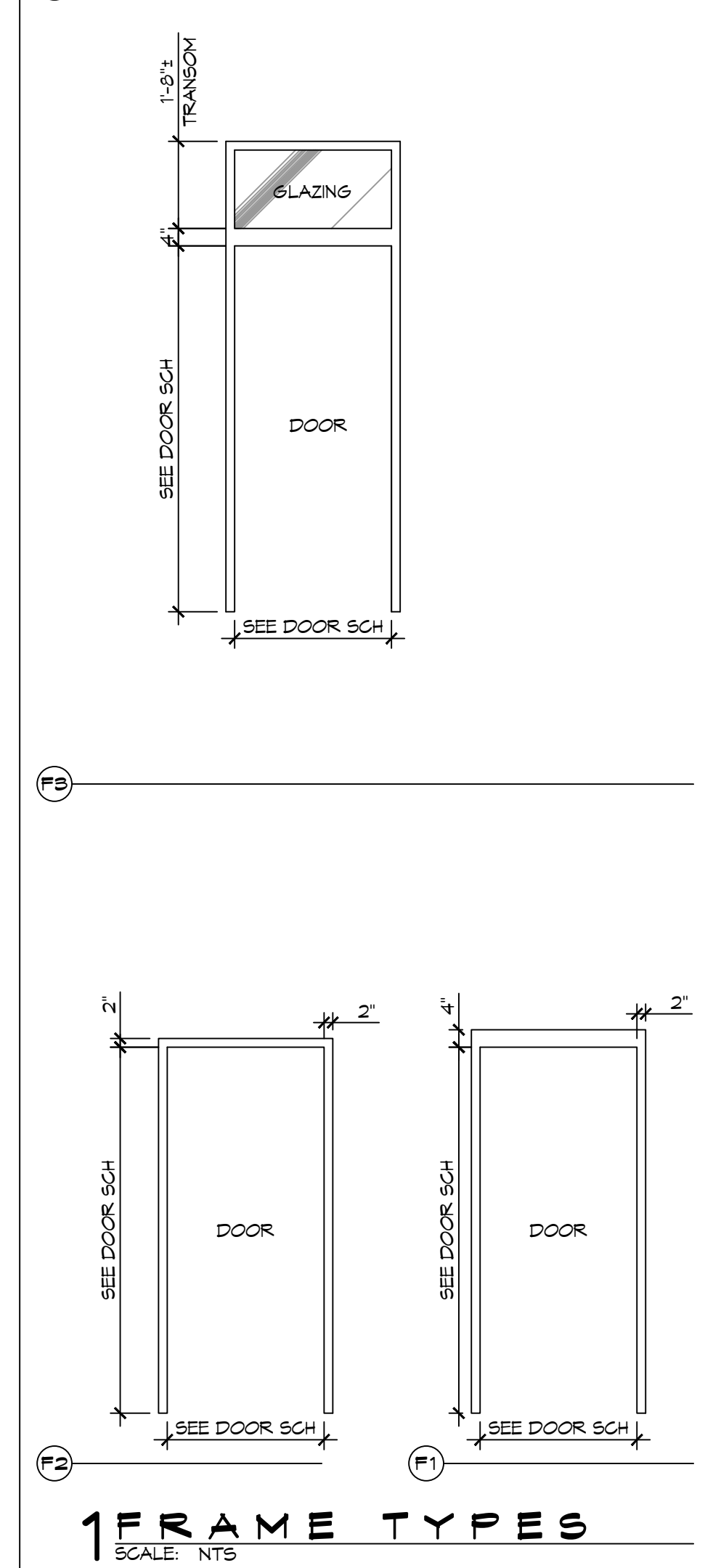
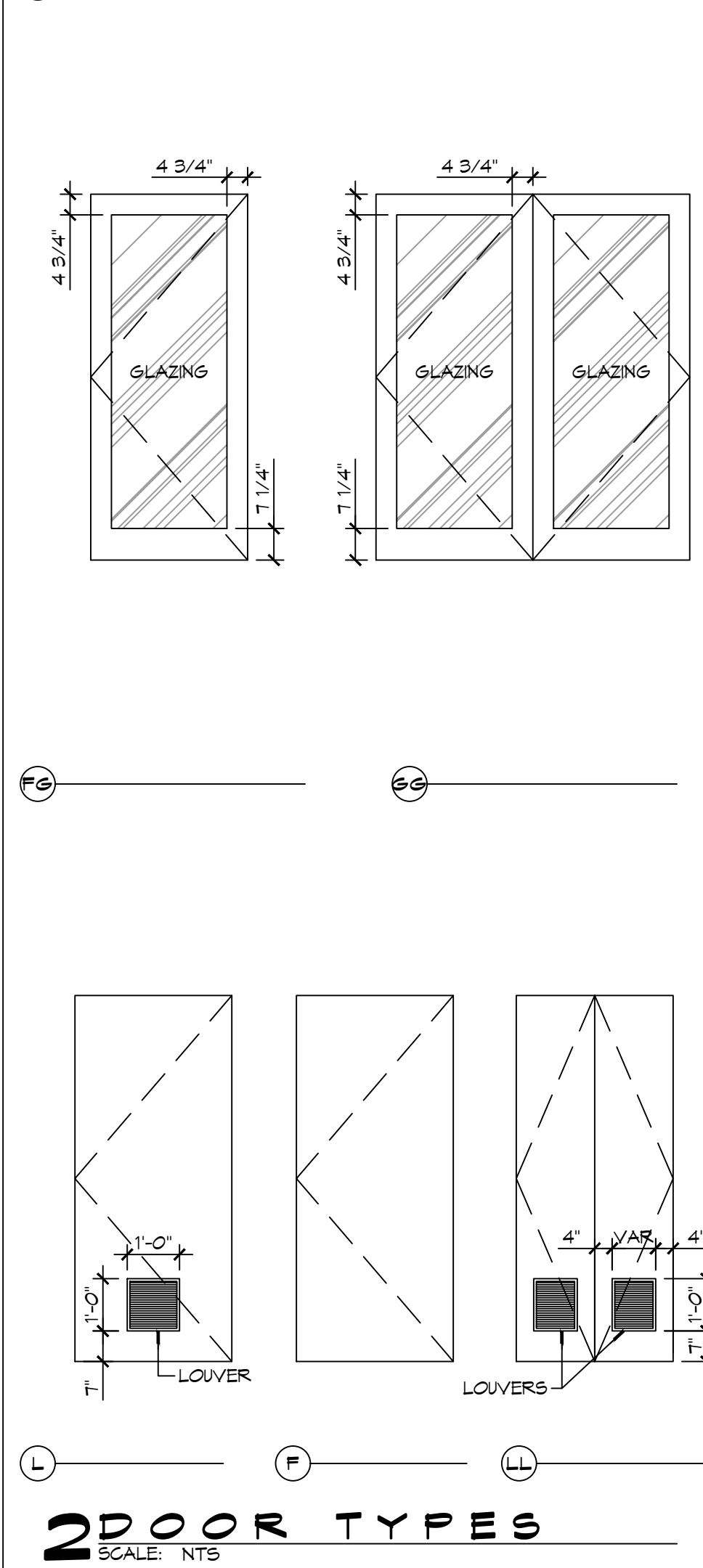
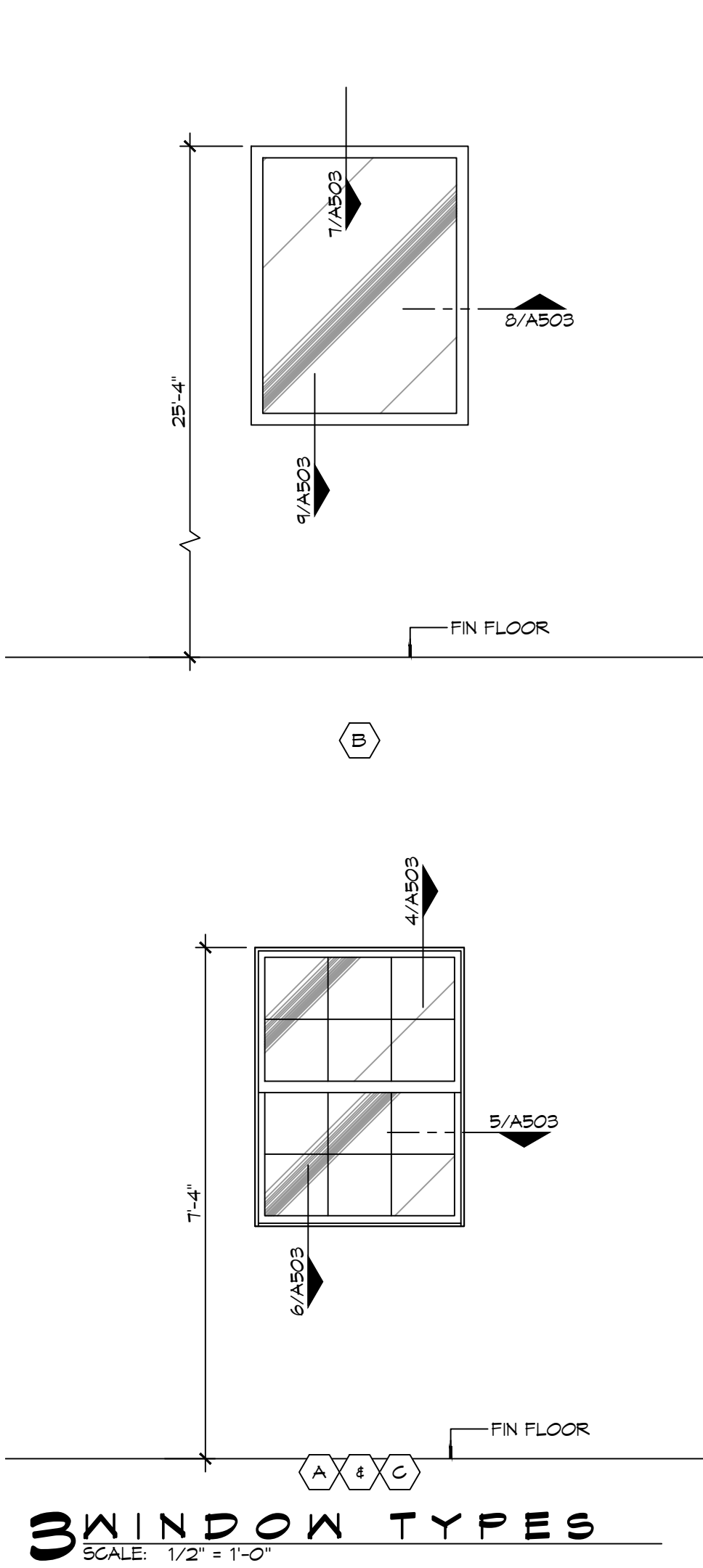
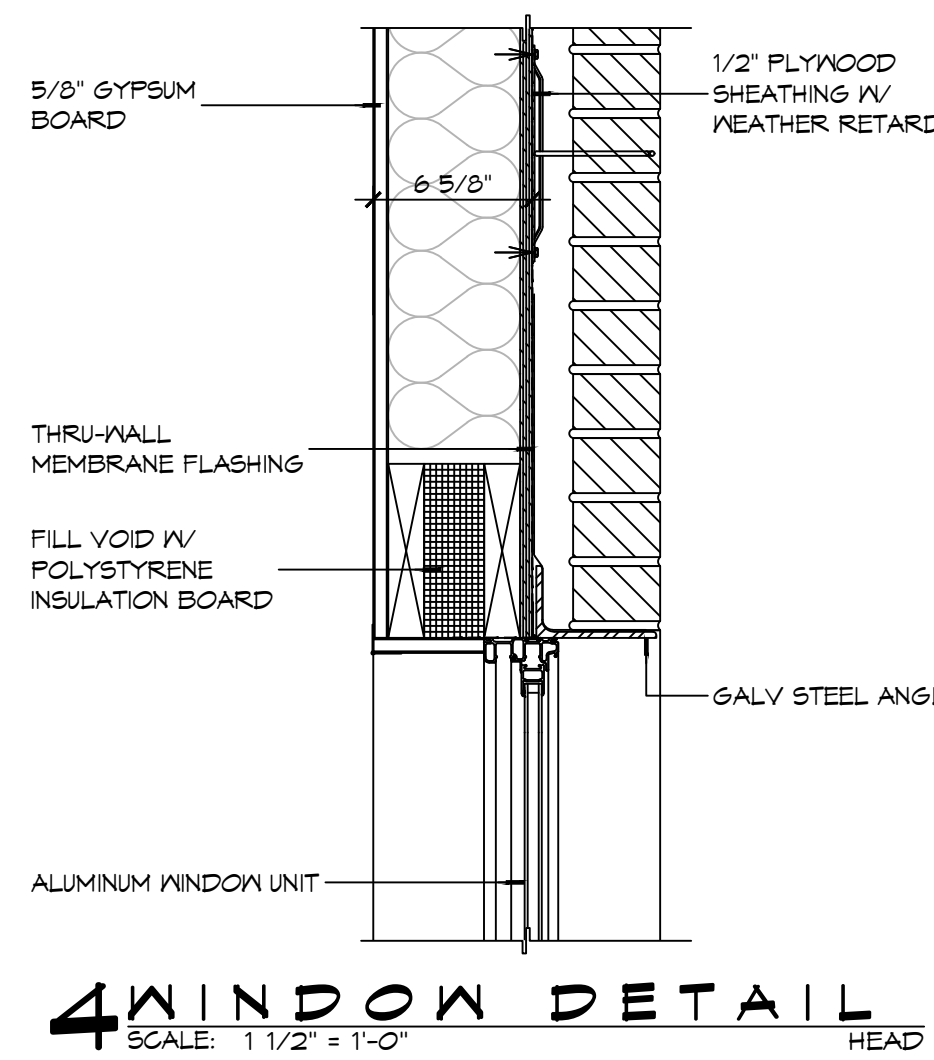
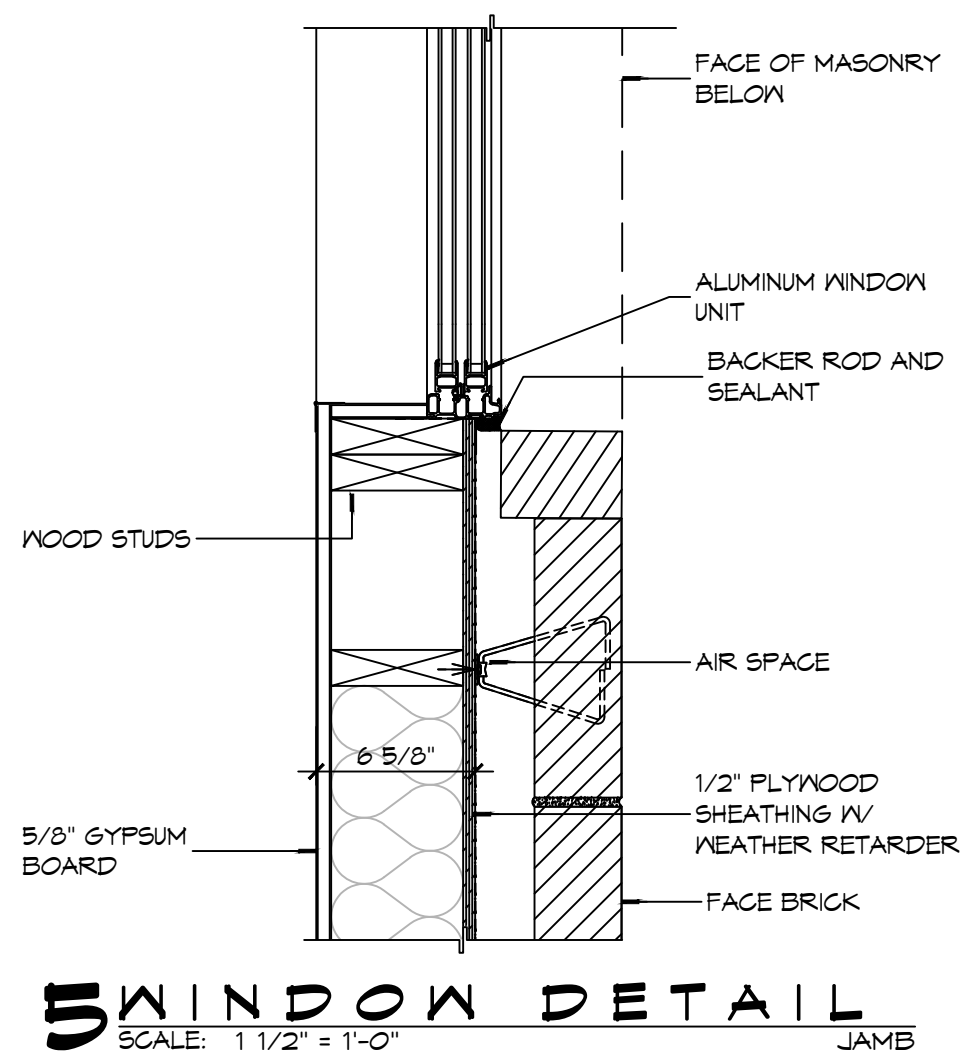
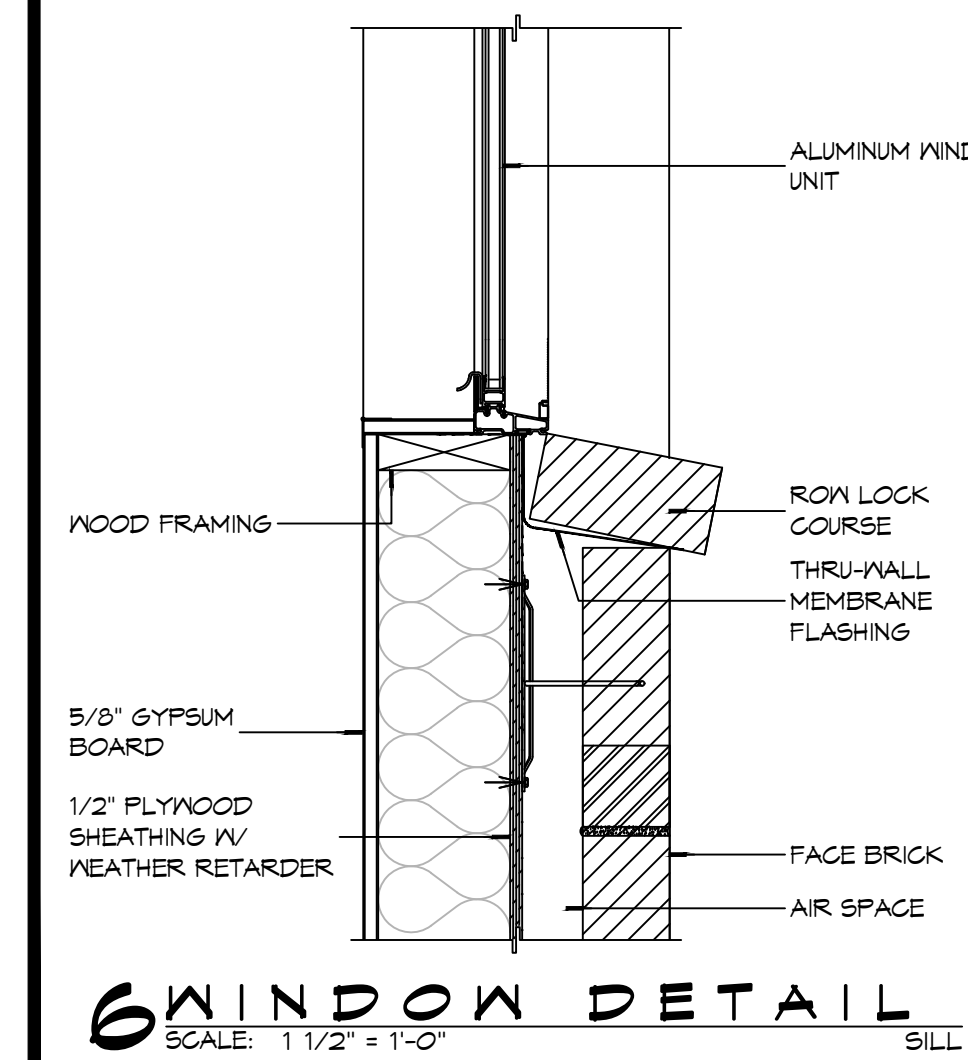
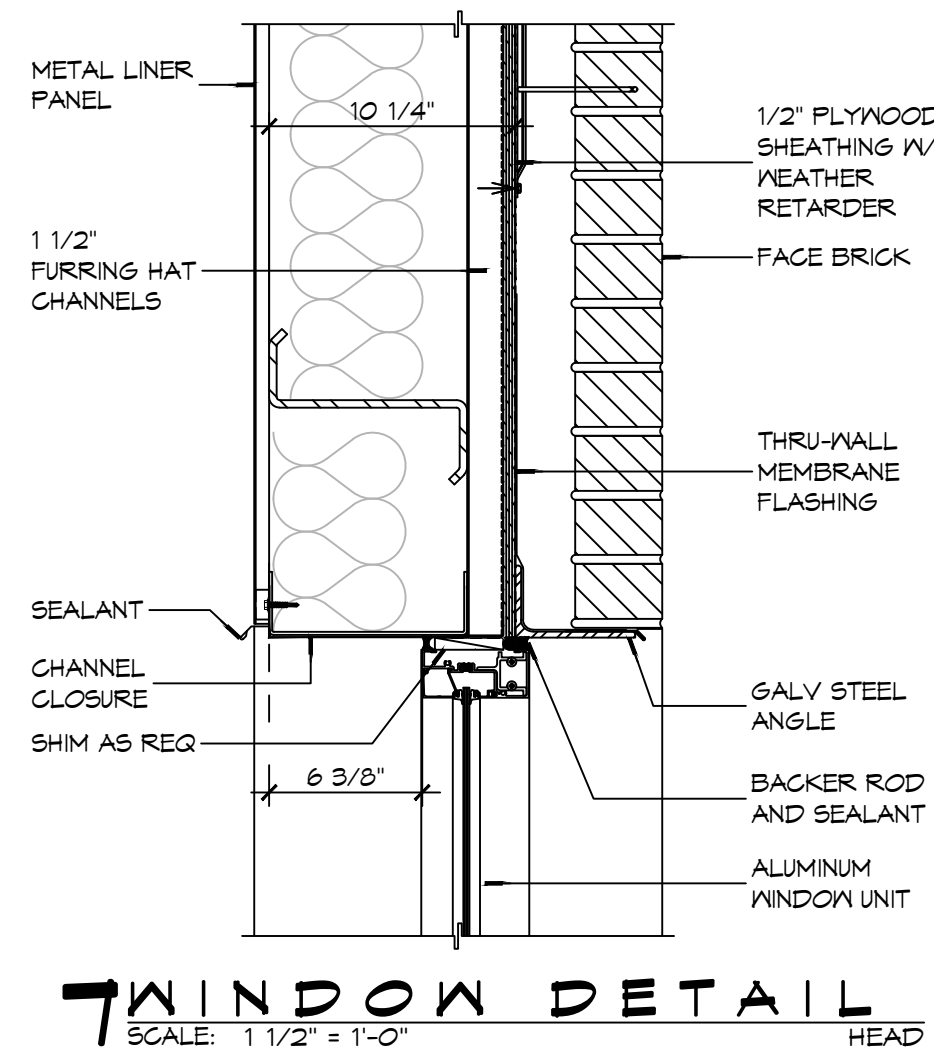
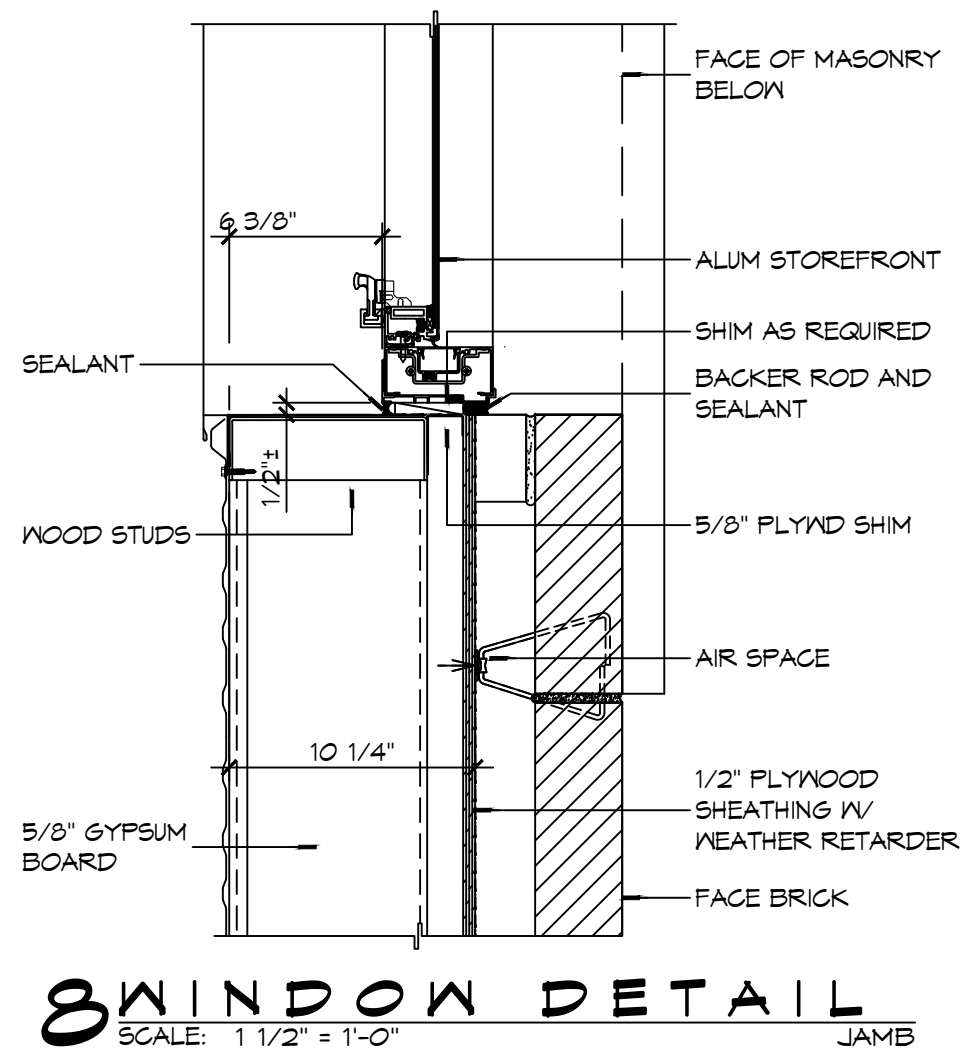
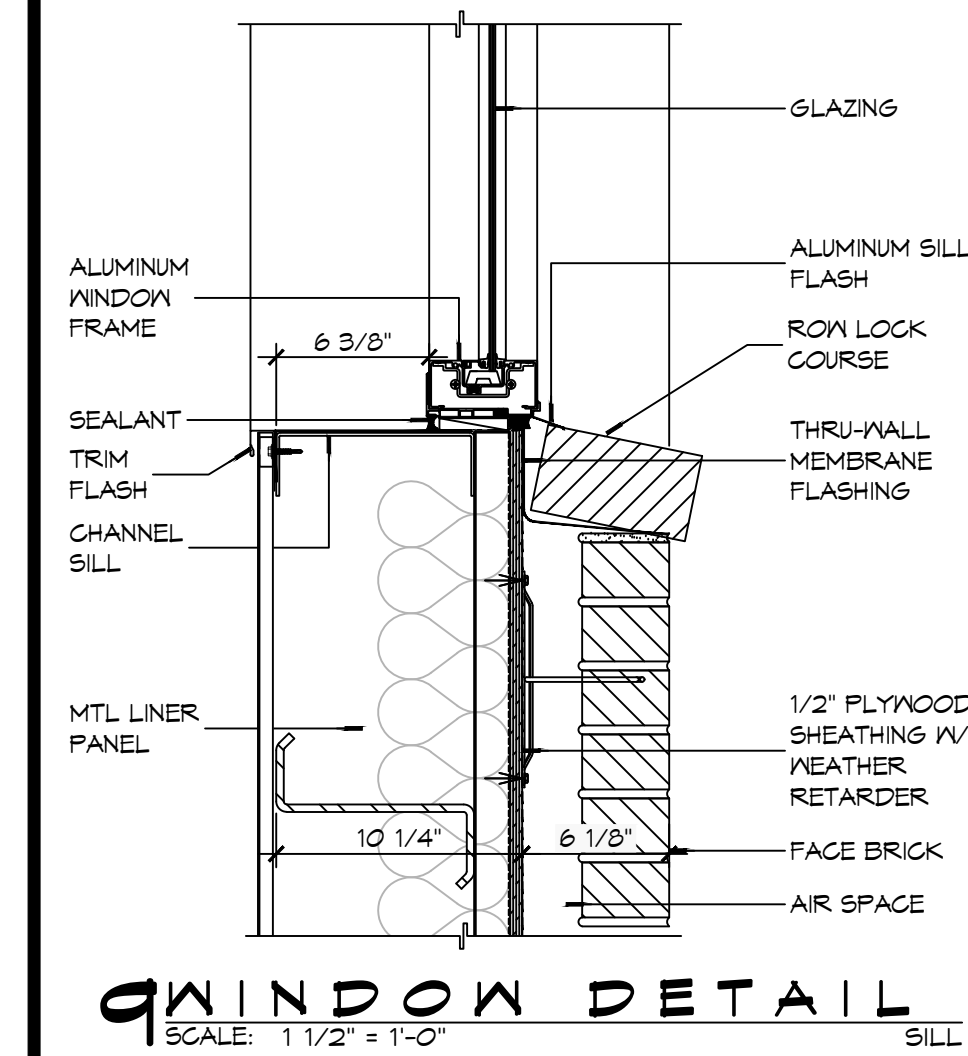

GENERAL OPENING SCHEDULE NOTES

- CONTRACTOR SHALL VERIFY ROUGH OPENING DIMENSIONS WITH MANUFACTURER'S REQUIREMENTS PRIOR TO CONSTRUCTION.
- ALL EGRESS DOORS SHALL BE READILY OPENABLE FROM THE EGRESS SIDE WITHOUT THE USE OF A KEY OR SPECIAL KNOWLEDGE OR EFFORT.
- ALL DOORS NOT SPECIFIED TO RECEIVE A THRESHOLD SHALL HAVE A 3/4\"/>

DOOR NOTES

- DOOR WIDTH REFERS TO MASONRY OPENING - COORDINATE UNIT WIDTH WITH JAMB DETAIL AND MANUFACTURER'S REQUIREMENTS.
- PROVIDE 3/4\"/>

DAMMON ENGINEERING, INC.
LOUISIANA & MISSISSIPPI

Chief Engineer: Brian Mistich, PE
554 Old Spanish Trail
Slidell, LA 70488
www.dammonengineering.com
info@dammonengineering.com
PH: 985.649.5832

#	DESCRIPTION	REVISIONS	DATE

SEAL:

**NEW FIRE STATION #10
ST. TAMMANY FIRE PROTECTION DISTRICT NO. 1**

246 LAKESHORE VISTA BLVD
SLIDELL, LA 70461

JOB No: 2519 DATE: 12-05-2025
DRAWN BY: GKD CHECKED BY: JMS

SHEET TITLE:
DOOR AND WINDOW SCHEDULES, DOOR, WINDOW TYPES, & WINDOW DETAILS

DRAWING NUMBER:
A503

SHEET No: 29 of 37

PLS. NAME: J.V. Gammone/0103 - Proj. Title: #10 Dammon General Plumbing/Plumbing Station #1. Date: 12/05/2025.

GENERAL PLUMBING NOTES

1. PLUMBING LINES SHOWN ARE DRAWN DIAGRAMMATIC IN NATURE AND REPRESENT CONCEPTUAL ROUTING ONLY. CONTRACTOR IS RESPONSIBLE FOR FIELD VERIFICATION OF ALL ACTUAL CONDITIONS.
2. PROVIDE ALL LABOR, MATERIAL, TRANSPORTATION, SUPERVISION, CLEAN-UP, SERVICES, AND EQUIPMENT FOR A COMPLETE OPERATING SYSTEM. THE SYSTEM SHALL INCLUDE HOT AND COLD WATER PIPING, SEWER AND VENT PIPING, INSULATION, WATER HEATER, HANGERS, VALVES, SUPPORTS WITHOUT ANY RESTRICTIONS TO VOLUME, CUT AND PATCH AS REQUIRED TO INSTALL PIPES.
3. ALL WORK AND MATERIAL SHALL CONFORM STRICTLY TO THE LATEST LOCAL CITY, PARISH, STATE AND NATIONAL GOVERNING CODES.
4. CONTRACTOR IS TO FIELD VERIFY ALL EXISTING UTILITY LOCATIONS, ELEVATIONS AND SIZES PRIOR TO COMMENCING ANY WORK. CONTRACTOR SHALL PAY NECESSARY FEES FOR THE UTILITIES CONNECTIONS.
5. CONTRACTOR IS RESPONSIBLE TO VERIFY THE EXISTING INVERTS AND SET NEW INVERTS OF SEWERAGE AND DRAINAGE PIPES.
6. SEWERAGE LINES 3-INCH AND SMALLER SHALL BE SLOPED 1/4" PER FOOT AND LINES 4-INCH AND LARGER SHALL BE 1/8" PER FOOT.
7. TEST ALL PIPING AT REQUIRED PRESSURE.
8. ALL PLUMBING SHALL BE CLOSELY COORDINATED WITH STRUCTURAL, MECHANICAL SYSTEM AND ELECTRICAL SYSTEMS TO INSURE NO TRADES WILL CONFLICT WITH EACH OTHER.
9. DO NOT SCALE DRAWINGS. SEE ARCHITECTURAL DRAWINGS FOR EXACT LOCATIONS OF DOORS, WINDOWS, WALLS, FIXTURES, ETC.
10. ALL WATER MAINS AND PIPING NOT SHOWN FOR CLARITY, ALL LOCATIONS FIELD VERIFIED.
11. DOMESTIC HOT AND COLD WATER PIPING AND FITTINGS UNDER SLAB SHALL BE ASTM B88 COPPER WATER TUBE, TYPE K, SOFT ANNEALED. NO JOINTS SHALL BE ALLOWED UNDER THE SLAB.
12. DOMESTIC WATER PIPING AND FITTINGS ABOVE THE SLAB SHALL BE ASTM B38 COPPER WATER TUBE, TYPE L, HARD DRAWN WITH COPPER PRESSURE TYPE FITTINGS, ANSI B16.22. THE JOINTS SHALL BE SOLDERED TYPE USING ASTM B32 ALLOY GRADE 95A (95-5) SOLDER.
13. SOIL, WASTE, VENT PIPING AND FITTINGS ABOVE THE SLAB SHALL BE SERVICE WEIGHT CAST IRON PIPE WITH BELL AND SPIGOT ENDS AND ONE PIECE NEOPRENE INSERT TYPE GASKET. USE PVC SCHEDULE 40 OR ABS DWV PIPES AND FITTINGS WHERE PERMITTED BY CODE.
14. ALL WATER PIPING AND FITTINGS ABOVE THE FLOOR SHALL BE INSULATED WITH 1/2" THICK FIBERGLASS INSULATION AND JACKET.
15. ALL ELECTRICAL, MECHANICAL AND PLUMBING ELEMENTS PENETRATING FIRE PARTITIONS SHALL BE FIRE CAULKED. (PENETRATIONS THROUGH RATED CONSTRUCTION SHALL BE SEALED WITH A MATERIAL CAPABLE OF PREVENTING THE PASSAGE OF FLAMES AND HOT GASES WHEN TESTED IN ACCORDANCE WITH ASTM-E814.)
16. SEE ROOF PLAN FOR PLUMBING ROOF PENETRATIONS. ROUTE VENT PIPES IN ATTIC AS NECESSARY.
17. SEE SHEET G103 FOR CONTINUATION OF UTILITIES FROM POINT APPROXIMATELY FIVE FEET OUTSIDE OF BUILDING PERIMETER.
18. ALL VENTS THROUGH ROOF (VTR) SHALL BE LOCATED A MINIMUM OF 10'-0" FROM ANY MECHANICAL OR NATURAL AIR INTAKE.

DRAWN DIAGRAMMATICALLY FOR CLARITY. FIELD VERIFY PLACEMENT OF ALL EQUIPMENT PRIOR TO FABRICATION.

DAMMON ENGINEERING, INC.
 LOUISIANA & MISSISSIPPI
 Chief Engineer: Brian Mistich, PE
 554 Old Spanish Trail
 Slidell, LA 70458
 www.dammonengineering.com
 info@dammonengineering.com
 PH: 985.649.5832

#	DESCRIPTION	DATE



NEW FIRE STATION #10
 ST. TAMMANY FIRE PROTECTION DISTRICT NO. 1
 2146 LAKESHORE VISTA BLVD
 SLIDELL, LA 70461
 JOB No: 2519 DATE: 12-05-2025
 DRAWN BY: CKD CHECKED BY: BAK

SHEET TITLE:
 PLUMBING PLAN - SEWER AND WASTE, AND MISC PLUMBING DETAILS
 DRAWING NUMBER:
P101
 SHEET No: 30 of 31

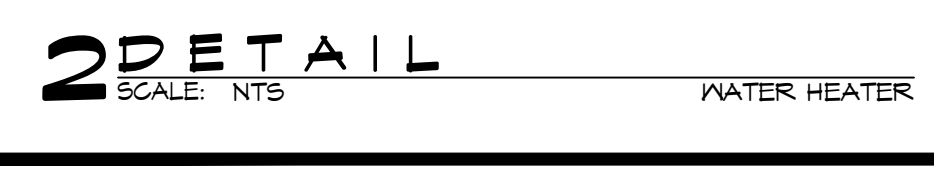
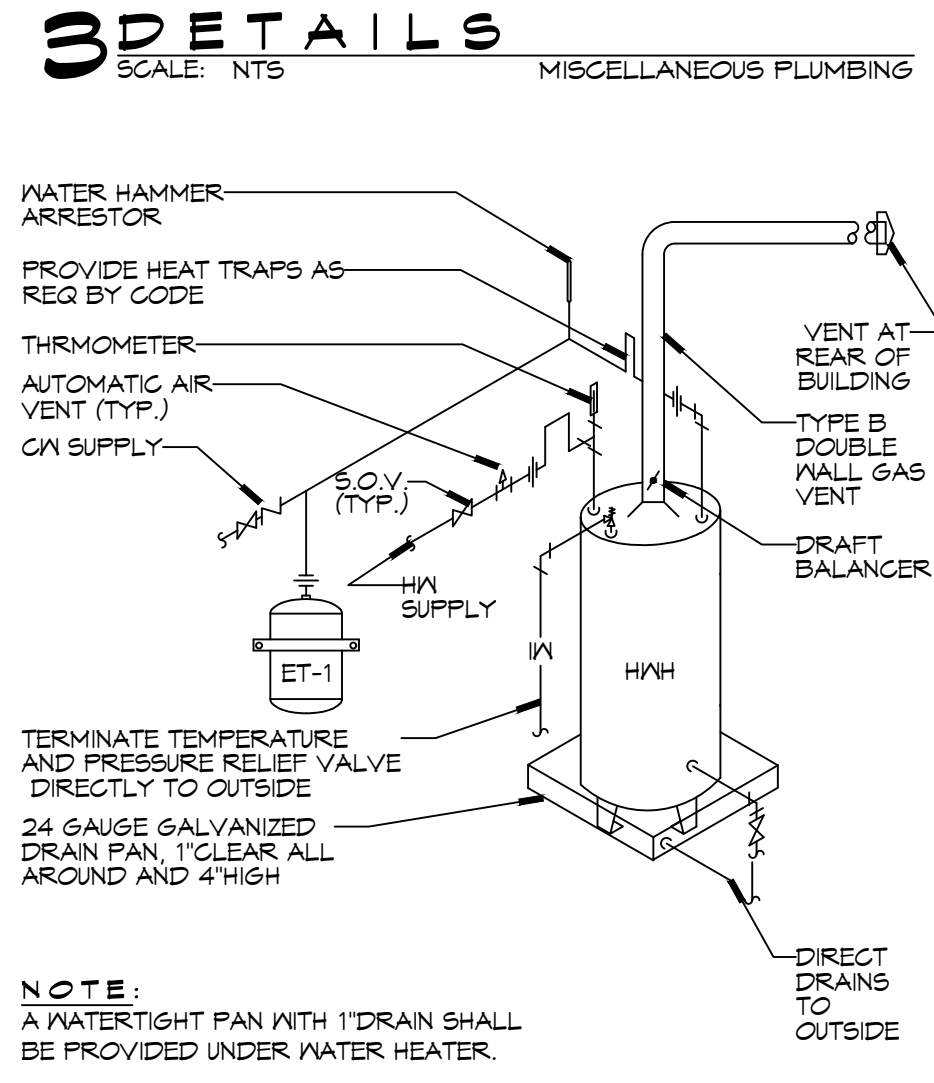
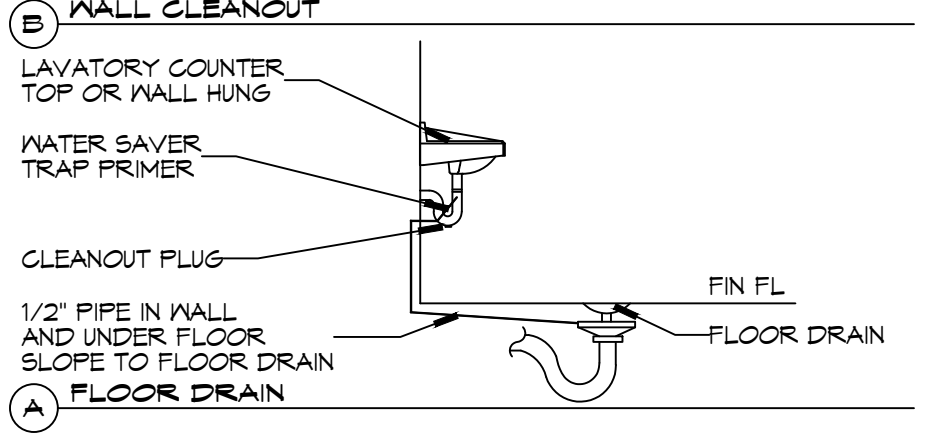
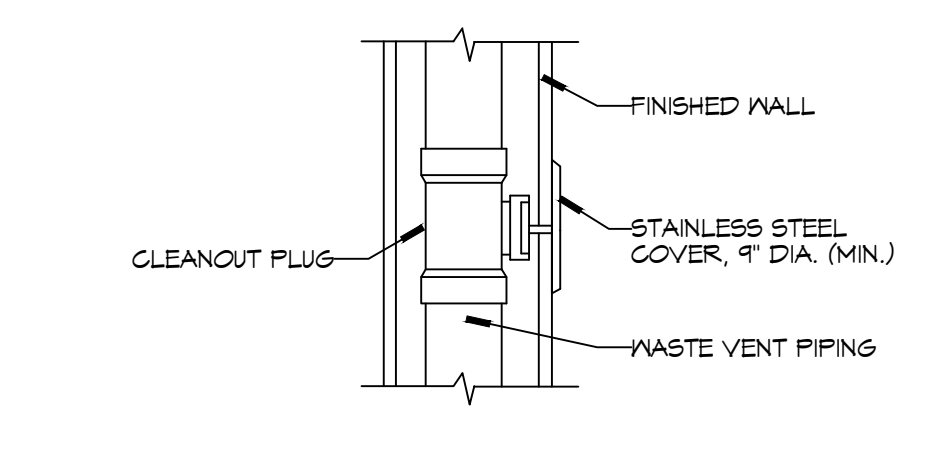
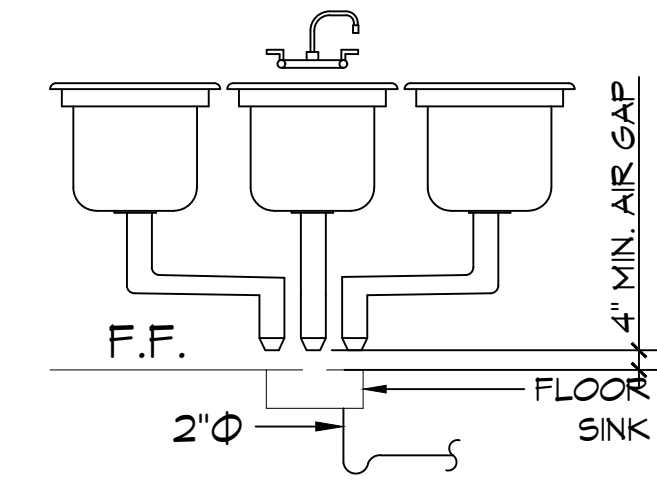
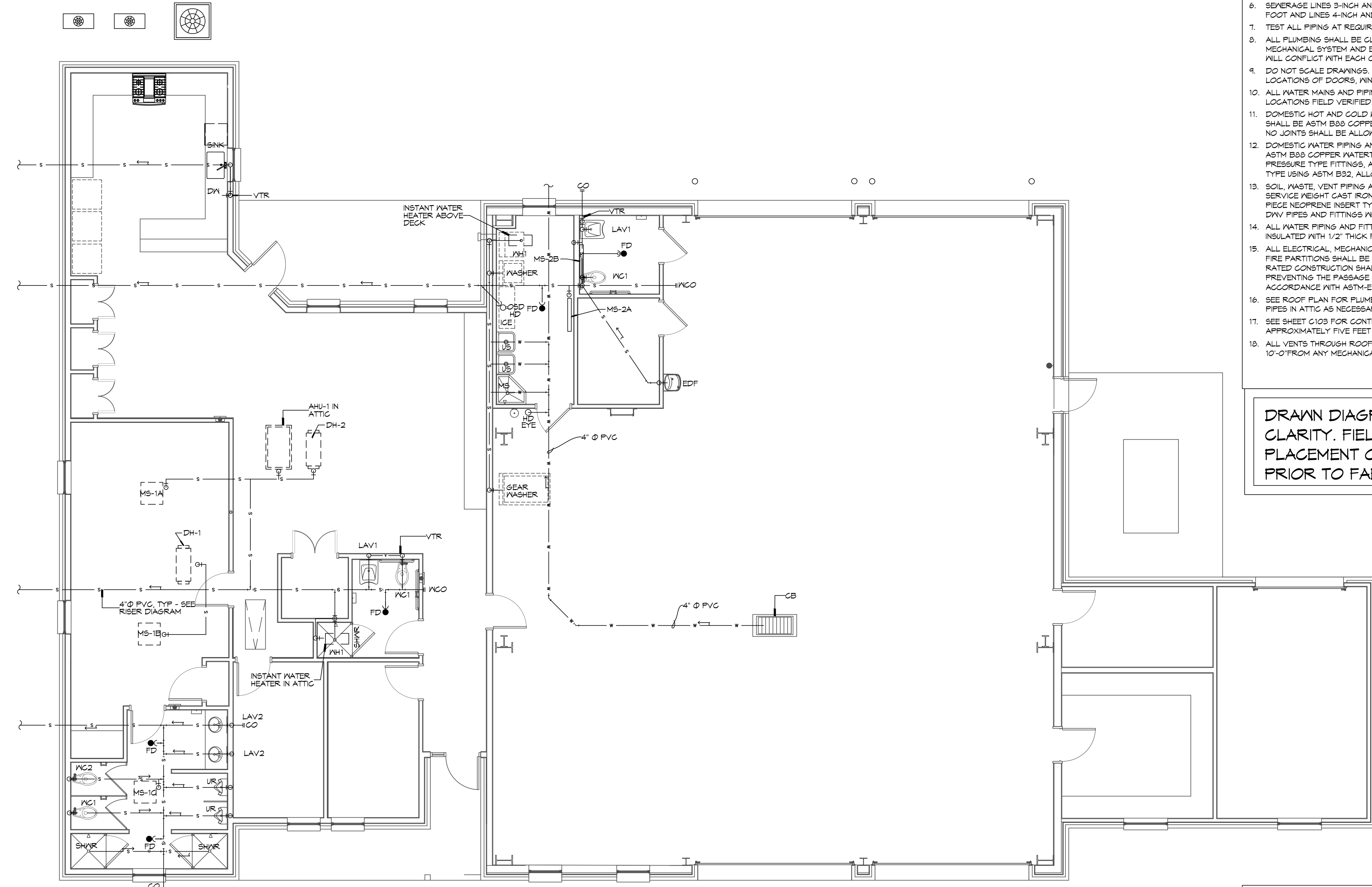

LEGEND	
SYMBOL	DESCRIPTION
—S—S—	SANITARY SEWER
—DW—DW—	POTABLE/DOMESTIC WATER
—V—V—	VENT PIPE
—W—W—	WASTE WATER
—GAS—GAS—	GAS PIPE
—C—C—	CONDENSATE PIPE
—●—FD	FLOOR DRAIN
—○—OSD	OPEN SIGHT DRAIN
— —CO	LINE CLEAN OUT
— —WCO	WALL CLEAN OUT

1 PLUMBING SEWER PLAN

SCALE: 3/16"=1'-0"

PLUMBING PLAN - WATER AND GAS
 SCALE: 3/16"=1'-0"
 2 PLUMBING PLAN - WATER AND GAS
 SCALE: 3/16"=1'-0"

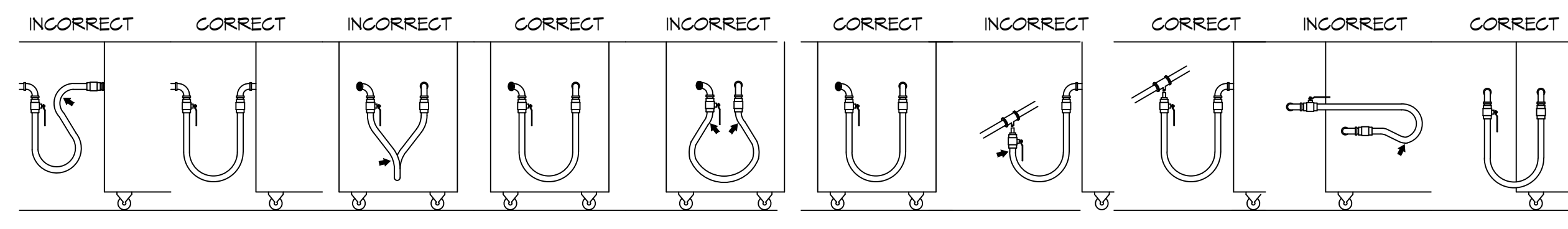

SHARP BENDS: THE CORRECT WAY TO INSTALL METAL HOSE FOR VERTICAL TRAVERSE IS WITH A SINGLE, NATURAL LOOP. AVOID SHARP BENDS THAT STRAIN AND TWIST THE METAL HOSE TO A POINT OF EARLY FAILURE AT THE COUPLING.
TWISTING: COUPLINGS AND HOSE SHOULD BE INSTALLED IN THE SAME VERTICAL PLANE. FAILURE TO DO SO CAUSES TORSIONAL TWISTING & UNIFORM STRAIN CAUSING PREMATURE FAILURE.
FATIGUE: MAINTAIN THE MINIMUM BENDING DIAMETER BETWEEN THE COUPLINGS. CREATES DOUBLE BENDS CAUSING WORK FATIGUE AT THE FITTINGS.
INCORRECT: AVOID SHARP BENDS AND KINKS (WHEN PULLING EQUIPMENT AWAY FROM WALL MAXIMUM FULL WILL KINK ENDS, EVEN IF INSTALLED PROPERLY, AND REDUCE CONNECTOR LIFE.
SELF-DRAINING: IN ALL INSTALLATIONS WHERE SELF-DRAINING IS NOT NECESSARY, CONNECT METAL HOSE IN A VERTICAL LOOP. DO NOT CONNECT METAL HOSE HORIZONTALLY UNLESS SELF-DRAINING IS NECESSARY, THEN USE SUPPORT ON LOWER PLANE.
CORRECT: MINIMUM PULL OF EQUIPMENT AWAY FROM WALL PERMISSIBLE FOR ACCESSIBILITY TO SUPR-QUIK DISCONNECT.

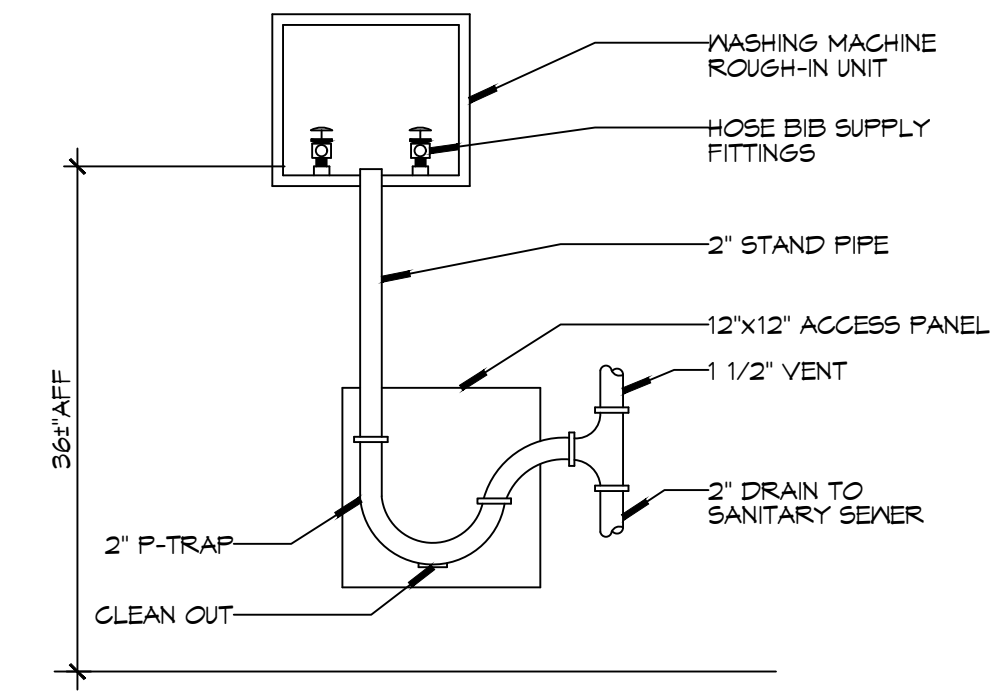

3 DETAIL
SCALE: NTS
WASHING MACHINE HOOK-UP

GENERAL PIPING NOTES

- SEE SHEET P101 FOR GENERAL PLUMBING NOTES.
- WATER LINES ON EXTERIOR WALLS SHALL BE ROUTED ON INTERIOR SIDE OF INSULATION.
- NOT USED.
- SEE PLUMBING RISER DIAGRAMS FOR PIPE SIZES NOT INDICATED ON THIS SHEET.

LEGEND

SYMBOL	DESCRIPTION
— CW —	COLD WATER SUPPLY PIPING (CW)
— HW —	HOT WATER SUPPLY PIPING (HW)
— THW —	TEMPERED WATER SUPPLY PIPING (THW)
— GAS —	GAS PIPING
⊗	GLOBE VALVE
⊕	TEMPERING VALVE
⊘	GAS COCK
⊙	HEATER
+0	ELBOW UP
-0	ELBOW DOWN
⊕	HOSE BIB
⊕	SPRINKLER RISER

GAS EQUIPMENT SCHEDULE

DESCRIPTION	BTU INPUT
RINNAI TANKLESS HOT WATER HEATER	199,900
RANGE	106,500
SPACE HEATER	125,000
CLOTHES DRYER	95,000
GENERATOR	1261000
TOTAL BTU	1,707,400

NOTES:

- ALL GAS PIPE SHALL BE SCHEDULE 40 BLACK STEEL PIPE. ALL PIPE INSTALLED ON ROOF SHALL BE SUPPORTED ON A PIPE PIER SUPPORT SYSTEM. WOOD BLOCKING NOT ALLOWED.
- ALL GAS PIPING IS SIZED FOR A LOW PRESSURE SYSTEM, (< 2 psig OR LESS AND A PRESSURE DROP OF 0.5in. OF WATER COLUMN.)

CONTACT FOR ATMOS ENERGY
 Kathleen A DuFour
 Account Representative
 Atmos Energy Corporation
 Louisiana Division
 985-373-9177 Cell
 kathleen.dufour@atmosenergy.com

CONTACT FOR MAGNOLIA WATER
 Steve Bressi
 Director, Louisiana Regulatory Relations
 Email: semst@scsurgroup.com
 M(905) 640-1355

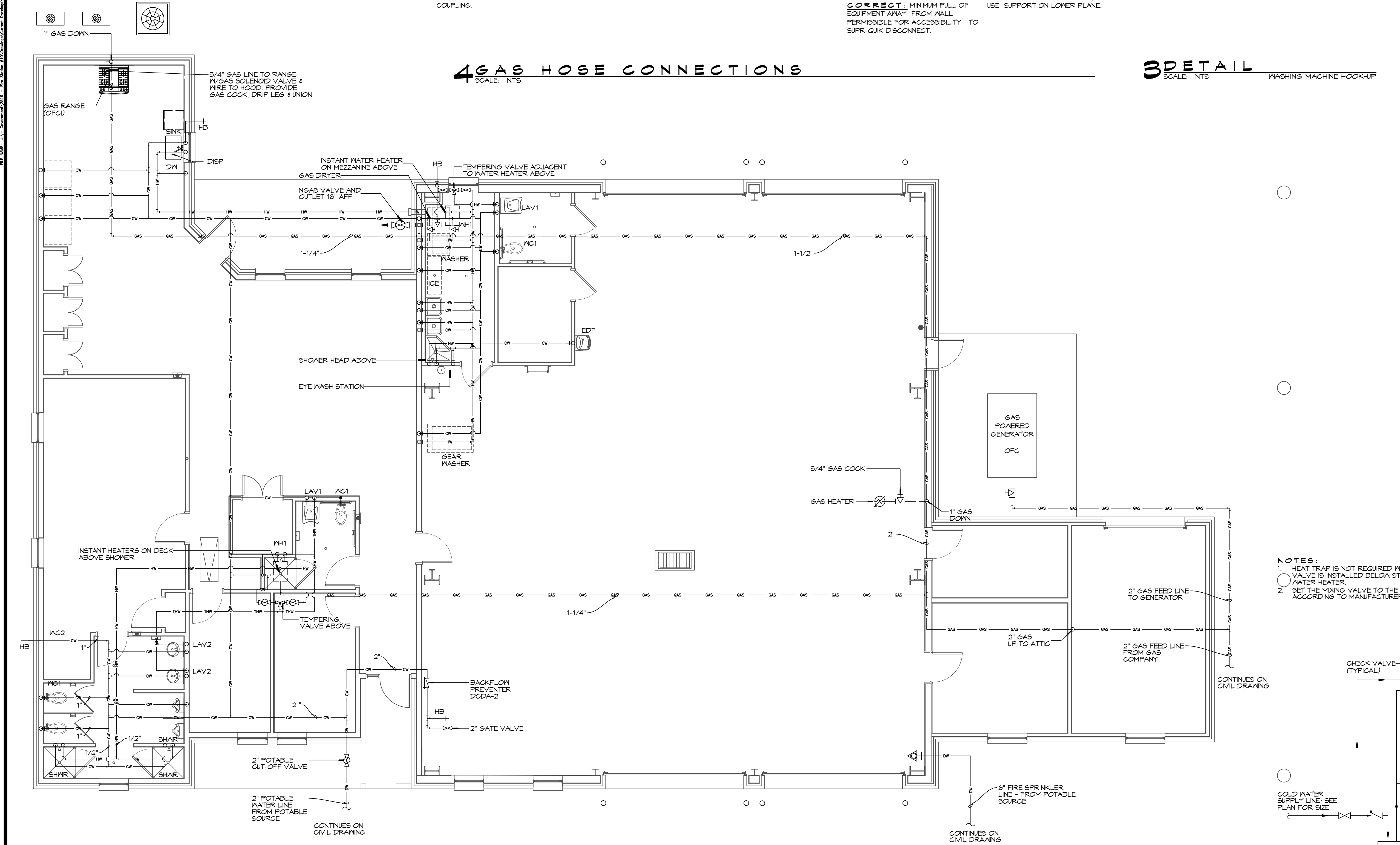

NOTES:

- HEAT TRAP IS NOT REQUIRED WHERE MIXING VALVE IS INSTALLED BELOW STORAGE TANK OR WATER HEATER.
- SET THE MIXING VALVE TO THE SYSTEM ACCORDING TO MANUFACTURER'S INSTRUCTIONS.

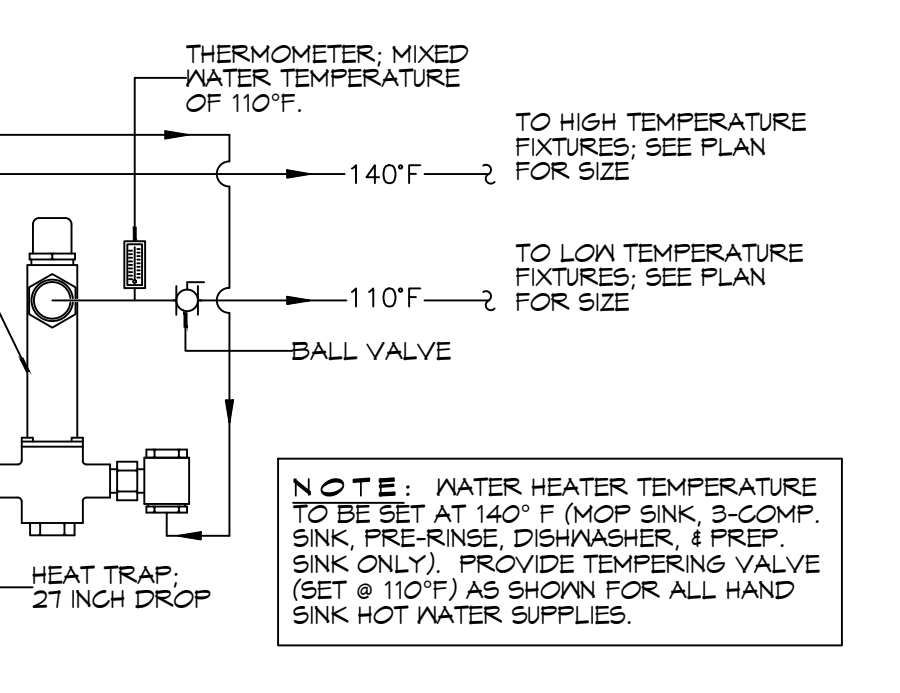

NOTE: WATER HEATER TEMPERATURE TO BE SET AT 140° F. (MOP SINK, 3-COMP. SINK, PRE-RINSE, DISHWASHER, & PREP SINK ONLY). PROVIDE TEMPERING VALVE (SET @ 110°F) AS SHOWN FOR ALL HAND SINK HOT WATER SUPPLIES.

2 PLUMBING PLAN - WATER AND GAS
SCALE: 3/16"=1'-0"

1 DETAIL
SCALE: NTS
TEMPERED WATER VALVE

DAMMON ENGINEERING, INC.
 LOUISIANA & MISSISSIPPI
 Chief Engineer: Brian Mistich, PE
 554 Old Spanish Trail
 Slidell, LA 70458
 www.dammonengineering.com
 info@dammonengineering.com
 PH: 985.649.5832

REVISIONS

#	DESCRIPTION	DATE



NEW FIRE STATION #10
ST. TAMMANY FIRE PROTECTION DISTRICT NO. 1
 248 LAKESHORE VISTA BLVD
 SLIDELL, LA 70461
 JOB No: 2519
 DATE: 12-05-2025
 DRAWN BY: BAW
 CHECKED BY: CKD

SHEET TITLE:
 PLUMBING PLAN - WATER AND GAS
 DRAWING NUMBER:
P102
 SHEET No: 31 of 37

PLUMBING FIXTURE SCHEDULE

MK	DESCRIPTION	TYPE	ROUGH-IN SIZE				BASIS OF DESIGN	NOTES
			WASTE	VENT	CM	HM		
WC1	HOT WATER CLOSET	VALVE	4"	2"	1"	-	SLOAN ELONGATED FLOOR MOUNTED ADA WATER CLOSET ST-2029, SLOAN ELECTRONIC FLUSH, W/ELONGATED WHITE SEAT	3,4
WC2	WATER CLOSET	VALVE	4"	2"	1"	-	SLOAN ELONGATED FLOOR MOUNTED ADA WATER CLOSET ST-2029, SLOAN ELECTRONIC FLUSH, W/ELONGATED WHITE SEAT	4
UR	URINAL	WALL HUNG	2"	2"	1/2"	-	SLOAN WASHDOWN URINAL SU-1009 SLOAN ELECTRONIC FLUSH	
LAV1	HOT LAVATORY	WALL HUNG	2"	2"	1/2"	1/2"	SLOAN BATHROOM SINK: 55-3103 SLOAN DOUBLE BLADE FAUCET	2,3,4
LAV2	LAVATORY	COUNTER	2"	2"	1/2"	1/2"	EMMA WASH BASIN 4-520 MOEN DOUBLE BLADE FAUCET 8215	1,2,3,4
FD	FLOOR DRAIN	-	2"	2"	-	-	JAY R. SMITH 2010-B-P, COATED CAST IRON W/ADJUSTABLE NICKEL BRONZE GRATE, TRAP PRIMER CONNECTION & DEEP SEAL TRAP.	4
US	UTILITY SINK	FLOOR	2"	2"	3/4"	3/4"	FIAT FL-1 FLOOR MOUNTED LAUNDRY SINK WITH DELTA LF 2HDL FAUCET	4
MS	MOP SINK	FLOOR	2"	2"	3/4"	3/4"	FIAT TSBC1611 MOP SINK WITH CHICAGO 8PT-RCF FAUCET, DELTA FAUCET MULTI-CHOICE VALVE BODY R10000-IPMS; DELTA FAUCET MULTI-CHOICE PRESSURE BALANCE SHOWER VALVE T13H153 AND T13H162	4
SINK	SINGLE KITCHEN SINK	UNDER COUNTER	2"	2"	3/4"	3/4"	KRAUS 32" UNDERMOUNT SINGLE BOWL KHU100-32 KOHLER THREE FUNCTION SPRAYHEAD K-29106	4
DISP	GARBAGE DISPOSAL	UNDER COUNTER	2"	2"	-	-	INSINKERATOR LC-50	4
DW	DISHWASHER	UNDER COUNTER	-	-	-	1/2"	OFGI	5
SHWR	SHOWER	-	3"	2"	1/2"	1/2"	36"X36" AQUATIC SHOWER W/GLASS DOOR, 1369BF-8C WITH DELTA FAUCET MULTI-CHOICE VALVE BODY R10000-IPMS, DELTA FAUCET MULTI-CHOICE PRESSURE BALANCE SHOWER VALVE T13H153 AND T13H162; AND JONES STEPHENS CORP. NO CAULK SHOWER STALL DRAIN AND SS STRAINER D40140.	4
MH1	WATER HEATER	GAS	-	3"	3/4"	3/4"	RINNAI 199I INSTANT NONCONDENSING WATER HEATER	4
N/A			-	-	-	-		
EDF	ELEC DRINKING FOUNTAIN	WALL HUNG	1-1/2"	1"	1/2"	-	ELKAY DRINKING FOUNTAIN WITH BOTTLE FILLER: ON-WALL, REFRIGERATED, 39 1/2 IN HT, GRAY, FILTERED	4
ICE	ICE MACHINE	FLOOR MOUNT	2"	2"	1/2"	-	OFGI	5
WASH	LAUNDRY WASHING MACHINE	FLOOR MOUNT	2"	1-1/2"	3/4"	3/4"	OFGI	5
DRYER	GAS CLOTHES DRYER	FLOOR MOUNT	-	-	-	-	OFGI	5
HB	FREEZE PROOF HOSE BIBB	WALL	-	-	1/2"	-	ZURN Z1341-BFP WALL FAUCET W/ BACKFLOW PREVENTER	4
FCO	FLOOR CLEAN-OUT	-	-	-	-	-	MADE W-6004-Y, CAST IRON W/ADJUSTABLE HOUSING, ROUND HEAVY CAST IRON VANDAL PROOF TOP. (ALTERNATE JOSAM NO. 50014-15)	4
WCO	WALL CLEAN-OUT	-	-	-	-	-	MADE W-8453-R6, WITH BRASS PLUG AND ROUND STAINLESS STEEL SECURED ACCESS COVER.	4
CB	CATCH BASIN	-	-	-	-	-	SGI PRECAST CB 24X24 W/CAST IRON FRAME AND GRATE U.S. FOUNDARY 4653/6337	4
OVS	OIL WATER SEPERATOR	-	-	-	-	-	50 GAL OIL WATER SEPERATOR	4
LS	NOT USED	-	-	-	-	-	NOT USED	4
DCDA-1	NOT USED	-	-	-	2"	-	NOT USED	4
DCDA-2	CHECK VALVE	-	-	-	2-1-2"	-	ZURN DOUBLE CHECK DETECTOR ASSEMBLY MODEL 3500A	4
ABH	APPARATUS BAY HEATER	WALL	-	-	-	-	SUPPLIED UNDER MECHANICAL CONTRACT STERLING MODEL TF 125	4
AHU	AIR HANDLING UNIT	-	2"	2"	-	-	SUPPLIED UNDER MECHANICAL CONTRACT	
EYE	EYEWASH STATION	FLOOR MOUNT	3"	2"	3/4"	3/4"	GUARDIAN 61825 EYEWASH	

NOTES:
 1. HOT WATER AND DRAIN PIPES UNDER LAVATORIES SHALL BE INSULATED OR OTHERWISE CONFIGURED TO PROTECT AGAINST CONTACT. THERE SHALL BE NO SHARP OR ABRASIVE SURFACES UNDER LAVATORIES.
 2. PROVIDE CHAIR CARRIER FOR ALL WALL-MOUNTED PLUMBING FIXTURES.
 3. INSTALL A CONTINUOUS DRIP VALVE ON ALL FLOOR DRAINS.
 4. PROVIDE FIXTURE AS DESIGNED OR PRIOR APPROVED EQUAL.
 5. OWNER FURNISHED AND CONTRACTOR INSTALLED (OFGI)
 TEMPERING VALVE

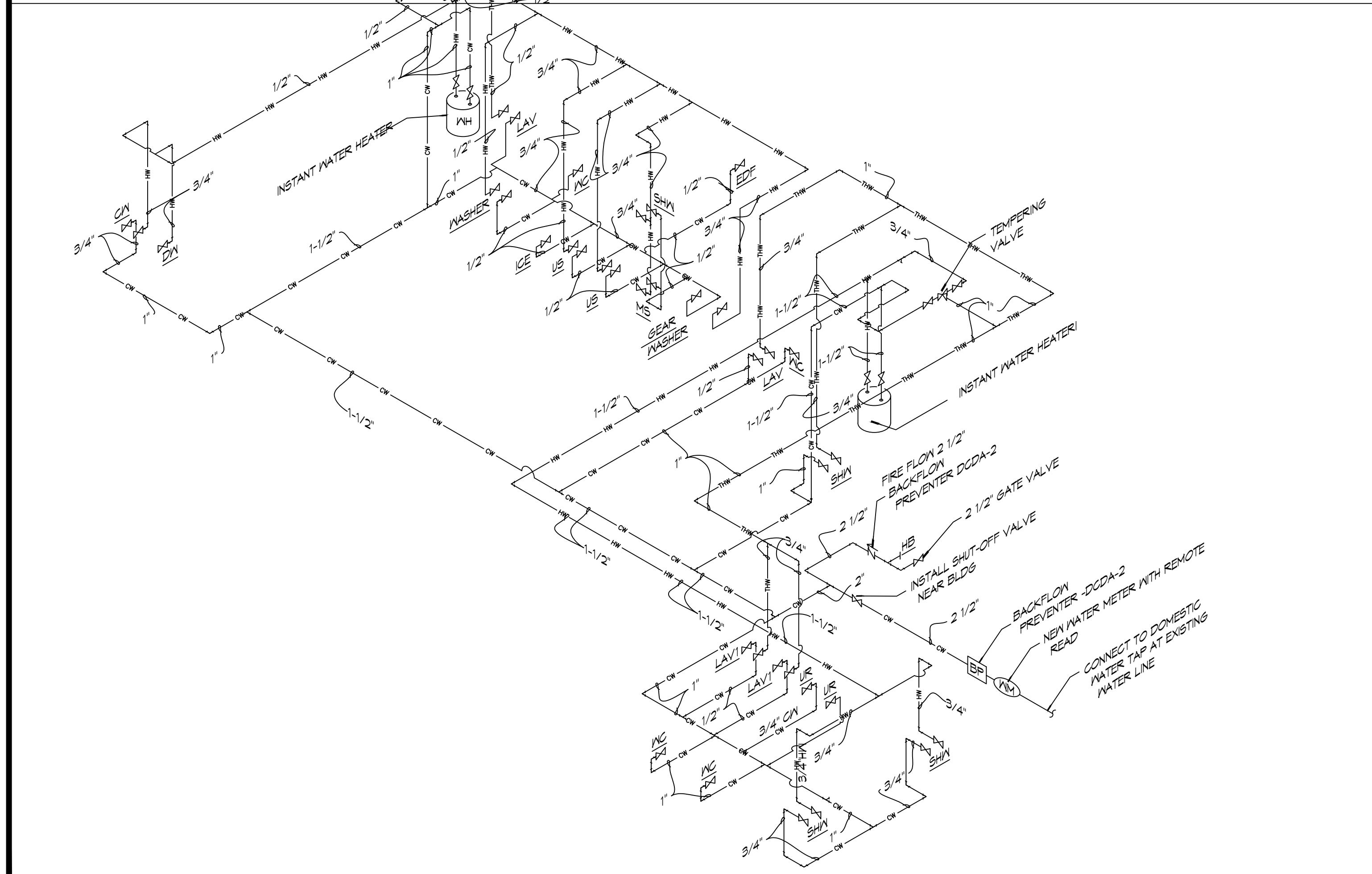

2 RISER DIAGRAM
SCALE: NTS
PLUMBING WATER SUPPLY

RISER DIAGRAM NOTES

1. PLUMBING LINES SHOWN ARE DRAWN DIAGRAMMATIC IN NATURE AND REPRESENT CONCEPTUAL ROUTING ONLY. CONTRACTOR IS RESPONSIBLE FOR FIELD VERIFICATION OF ALL ACTUAL CONDITIONS.
2. DO NOT SCALE DRAWINGS. SEE ARCHITECTURAL DRAWINGS FOR EXACT LOCATIONS OF DOORS, WINDOWS, WALLS, FIXTURES, ETC.
3. ALL ELECTRICAL, MECHANICAL AND PLUMBING ELEMENTS PENETRATING FIRE PARTITIONS SHALL BE FIRE CAULKED. ALL WALLS AND (PENETRATIONS THROUGH RATED CONSTRUCTION SHALL BE SEALED WITH A MATERIAL CAPABLE OF PREVENTING THE PASSAGE OF FLAMES AND HOT GASES WHEN TESTED IN ACCORDANCE WITH ASTM-E814.)
4. SEE SHEET P101 FOR GENERAL PLUMBING NOTES.
5. SEE ROOF PLAN FOR INTENDED LOCATIONS OF ALL ROOF PENETRATIONS.
6. SEE CIVIL DRAWINGS FOR SITE DRAINAGE CATCH BASIN LOCATIONS.

CONTACT FOR ATMOS ENERGY:
 Kathleen A Dufour
 Account Representative
 Atmos Energy Corporation
 Louisiana Division
 985-373-9171 Cell
 kathleen.dufour@atmosenergy.com

CONTACT FOR MAGNOLIA WATER:
 Steve Ernst
 Director, Louisiana Regulatory Relations
 Email: sernst@swrgroup.com
 M:(985) 640-1355

3 RISER DIAGRAM
SCALE: NTS

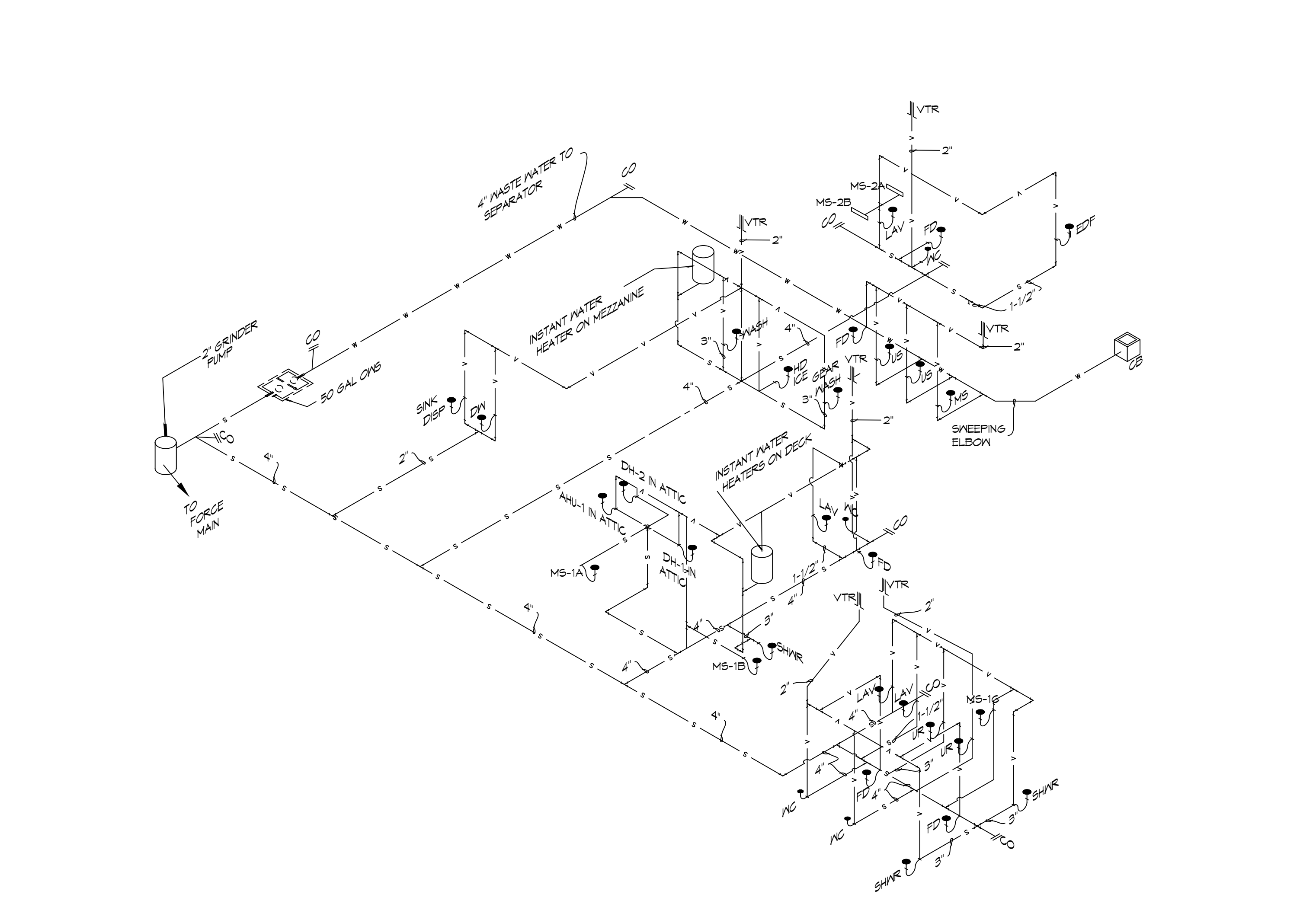

3 RISER DIAGRAM
SCALE: NTS
PLUMBING SEWER AND WASTE WATER

DAMMON ENGINEERING, INC.
 LOUISIANA & MISSISSIPPI
 Civil Engineer: Brian Mistich, PE
 554 Old Spanish Trail
 Slidell, LA 70458
 www.dammonengineering.com
 info@dammonengineering.com
 PH: 985-649-5832

#	DESCRIPTION	DATE



**NEW FIRE STATION #10
 ST. TAMMANY FIRE PROTECTION
 DISTRICT NO. 1**
 2148 LAKESHORE VISTA BLVD
 SLIDELL, LA 70461
 JOB NO: 2519
 DATE: 12-05-2025
 DRAWN BY: CKD
 CHECKED BY: BAK

SHEET TITLE:
**PLUMBING AND GAS RISER
 DIAGRAMS**
 DRAWING NUMBER:
P103
 SHEET No: 32 of 37

LEGEND

⊗ ELECTRIC SPACE HEATER - SEE HEATER SCHEDULE
 ⊗ GAS SPACE HEATER - SEE HEATER SCHEDULE
 ⊕ SUPPLY AIR GRILLE
 ⊖ RETURN AIR GRILLE
 ⊕ EXHAUST FAN/LIGHT - SEE SCHEDULE FOR HEATER OPTION
 ⊕ EXHAUST FAN ONLY
 ⊕ OUTSIDE AIR INTAKE DUCT W/ VOLUME DAMPER AND MOTORIZED OR GRAVITY DAMPER TO SHUT OFF WHEN SYSTEM IS NOT RUNNING
 ⊕ THERMOSTAT
 ⊕ LINE VOLTAGE THERMOSTAT (PROVIDED BY MG)
 ⊕ FD FIRE DAMPER
 ⊕ SD SMOKE DAMPER
 ⊕ VD SMOKE DAMPER
 ⊕ 15FD SMOKE & FIRE DAMPER
 ⊕ 15BD BACK DRAFT DAMPER
 ⊕ ROUND FLEX DUCT, MAX. LENGTH 12'-0", MIN R-8, PROVIDE MANUAL DAMPER AT DIFFUSER CONNECTIONS, DUCT SIZE AS FOLLOWS:
 250CFM TO 350CFM = 9"
 200CFM TO 250CFM = 8"
 150CFM TO 200CFM = 7"
 100CFM TO 150CFM = 6"
 ⊕ A/C CONDENSING UNIT
 ⊕ AHU UNIT
 ⊕ SUPPLY
 ⊕ RETURN
 ⊕ MOTORIZED DAMPER
 ⊕ DEHUM
 ⊕ BACKDRAFT DAMPER

GENERAL HVAC NOTES

1. CONCEALED DUCTWORK TO BE GALVANIZED SHEET METAL LINED WITH FIBROUS GLASS DUCT LINER, MIN R-6, INSTALLED PER SMACNA STANDARDS.
2. EXPOSED DUCTWORK TO BE GALVANIZED SHEET METAL LINED WITH FIBROUS GLASS DUCT LINER, MIN R-6, INSTALLED PER SMACNA STANDARDS.
3. ROUND FLEXIBLE DUCT TO BE UL-181, CLASS 1, AIR DUCT MATERIALS.
4. DUCT SIZES SHOWN ARE CLEAR INSIDE DIMENSIONS.
5. IN ALL SYSTEMS OVER 2000 CFM AND LESS THAN 15,000 CFM, SMOKE DETECTORS SHALL BE INSTALLED IN ACCORDANCE WITH NFPA 12E IN THE RETURN DUCT DOWNSTREAM OF THE AIR HANDLING UNIT AND ALL FILTERS TO AUTOMATICALLY STOP THE FAN.
6. PROVIDE UL LISTED 125 °F FIRESTAT IN RETURN AIR OF EACH SYSTEM UNDER 2000 CFM TO SHUT DOWN THE FAN IN THE EVENT OF FIRE.
7. PROVIDE UL RATED FIRE DAMPERS WHERE REQUIRED AT ALL DUCT PENETRATIONS OF FIRE-RATED ASSEMBLIES AND WHERE REQUIRED BY CODE, INCLUDING OUTSIDE AIR INTAKES AND EXHAUST FANS.
8. CONDENSATE DRAINS TO BE PVC PIPE RUN TO PLUMBERS P-TRAP WITHIN FIVE FEET OF AIR HANDLING UNITS.
9. ALL AIR HANDLING SYSTEMS TO BE BALANCED TO ASSURE PROPER AIR FLOWS PER PLANS.
10. ALL THERMOSTATS TO BE AUTOMATIC CHANGEOVER WITH HEAT SWITCH.
11. EXHAUST FAN SHALL BE CONTROLLED BY A SWITCH ON THE WALL IN THE SAME LOCATION AS LIGHT SWITCH(S). PROVIDE BACK DRAFT DAMPER.
12. PROVIDE AND INSTALL WATER PROOF GRILLE VENT IN PROPER ROOF LOCATION FOR PLUMBING FIXTURE EXHAUST.
13. ALL SUPPLY AIR VENTS SHALL BE EQUIPPED WITH AIR CONTROL DAMPERS AT THE REGISTER.
14. LOCATE OUTDOOR UNITS AS SHOWN ON ARCHITECTURAL DRAWINGS.
15. REFRIGERANT LINES SHALL BE SIZED BY UNIT MANUFACTURER AND INSTALLED ACCORDING TO MANUFACTURER'S INSTRUCTIONS.
16. FRESH AIR SHALL BE SUPPLIED TO EACH AIR HANDLER THROUGH EXTERIOR WALL DUCT SUPPLIED WITH A CONTROL DAMPER.
17. ALL ELECTRICAL, MECHANICAL, AND PLUMBING PENETRATING FIRE WALLS SHALL BE FIRE CAULKED. PENETRATIONS THROUGH RATED CONSTRUCTION SHALL BE SEALED WITH A MATERIAL CAPABLE OF PREVENTING THE PASSAGE OF FLAMES AND HOT GASES WHEN TESTED IN ACCORDANCE WITH ASTM-E8-14).
18. ALL MECHANICAL SYMBOLS ARE DRAWN DIAGRAMMATICALLY, CONTRACTOR TO VERIFY WITH OWNER LOCATIONS OF VENTS, DAMPERS, REGISTERS, ETC.
19. FLEXIBLE DUCTWORK LENGTH NOT TO EXCEED 12'-0".
20. REFER TO REFLECTED CEILING PLAN FOR FINAL GRILLE AND DIFFUSER LOCATIONS AND COORDINATE AS REQUIRED.
21. FINAL LOCATION OF TEMPERATURE CONTROLS TO BE COORDINATED WITH OWNER AT JOB SITE.
22. PROVIDE AND INSTALL SMOKE DETECTORS AS APPROVED BY LOCAL AHJ'S. PLACE NEAR R/A AND S/A OPENINGS OF AHU AND PROVIDE, WITH ACCESS PANEL, WIRING BY ELECTRICAL CONTRACTOR.
23. FRESH AIR INTAKES ARE REQUIRED TO HAVE MOTORIZED OR GRAVITY DAMPERS TO SHUT OFF WHEN SYSTEM IS NOT RUNNING.
24. PROVIDE BIRD SCREENS AT ALL EXTERIOR MECHANICAL PENETRATIONS.
25. COORDINATE WALL MOUNTED THERMOSTAT LOCATIONS WITH ALL OWNER FURNISHED ITEMS EITHER WALL MOUNTED OR FLOOR MOUNTED AGAINST PARTITIONS. REFER TO ARCHITECTURAL DRAWINGS.
26. SEE ROOF PLAN FOR ALL ROOF PENETRATIONS.
27. PROVIDE MIN 16 GA GALVANIZED SHEET METAL TO BLANK-OFF GABLE VENTS WHERE INTAKE/EXHAUST DUCTS OCCUR.
28. CONTRACTOR SHALL PERFORM BLOWER DOOR AND AIR DUCT LEAKAGE TESTING IN ACCORDANCE WITH ANSI/RESNET/ICC 380 - 2022. DUCT LEAKAGE SHALL COMPLY WITH 2021 IECC STANDARDS WITH A MAXIMUM LEAKAGE OF 4 CFM/100 SQUARE FOOT OF CONDITIONED AREA. BLOWER DOOR LEAKAGE SHALL NOT EXCEED 5 AIR CHANGES PER HOUR AT 50 PASCAALS (ACH 50). A REPRESENTATIVE FROM FD-1 WILL BE PRESENT FOR THESE TESTS.

DAMMON ENGINEERING, INC.
LOUISIANA & MISSISSIPPI
Chief Engineer: Brian Mistich, PE
554 Old Spanish Trail
Slidell, LA 70458
www.dammonengineering.com
info@dammonengineering.com
PH: 985-649-5832

NOTE: INSTALL FIRE DAMPER AT ANY LOCATION WHERE DUCT PENETRATES A FIRE WALL.

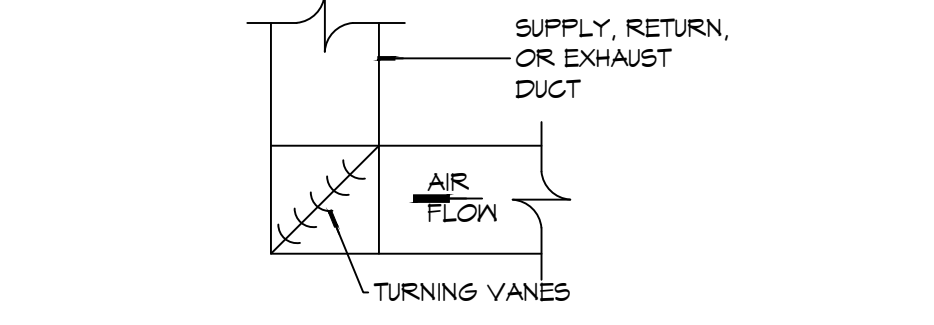

A SQUARE ELBOW

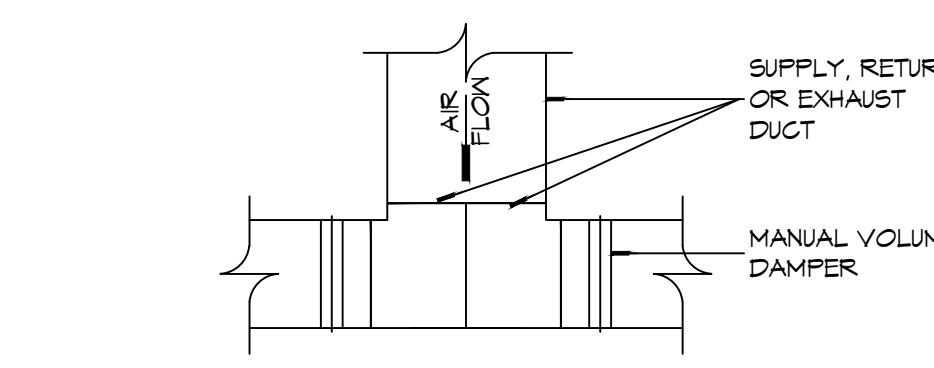

B DUCT SPLITTER

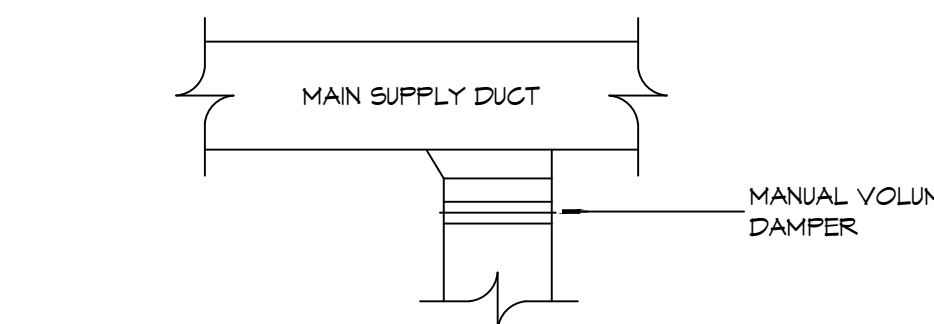

C SUPPLY DUCT TAKE-OFF

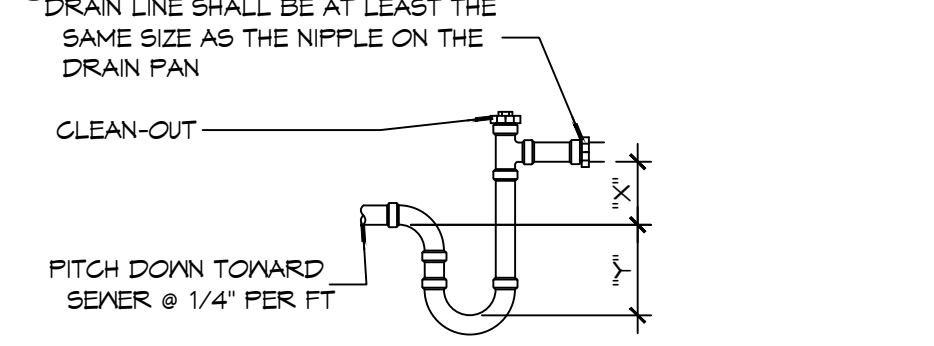

NOTES:
 1. LENGTHS "X" AND "Y" SHALL BE DETERMINED BY AHU BASED ON TOTAL STATIC PRESSURE.
 2. "X" AND "Y" SHALL BE EQUAL TO MINIMUM 1/2 TOTAL UNIT STATIC PRESSURE.
 3. ALL CONDENSATE PIPING SHALL BE SLOPED AT 1/4" PER FOOT.

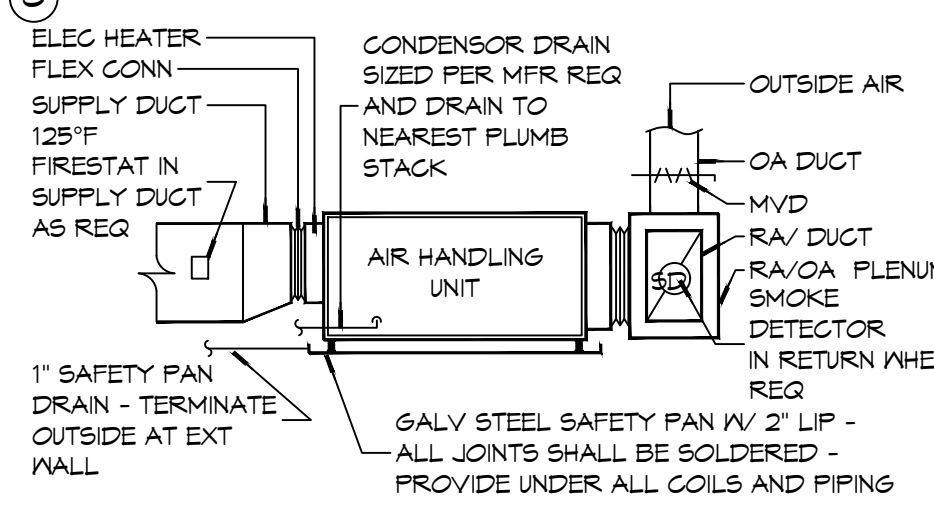

E TYPICAL HORIZONTAL AHU

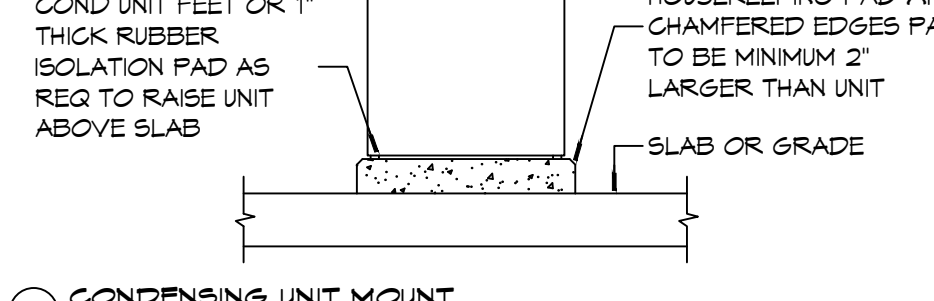

F CONDENSING UNIT MOUNT

2 DETAILS
SCALE: NTS

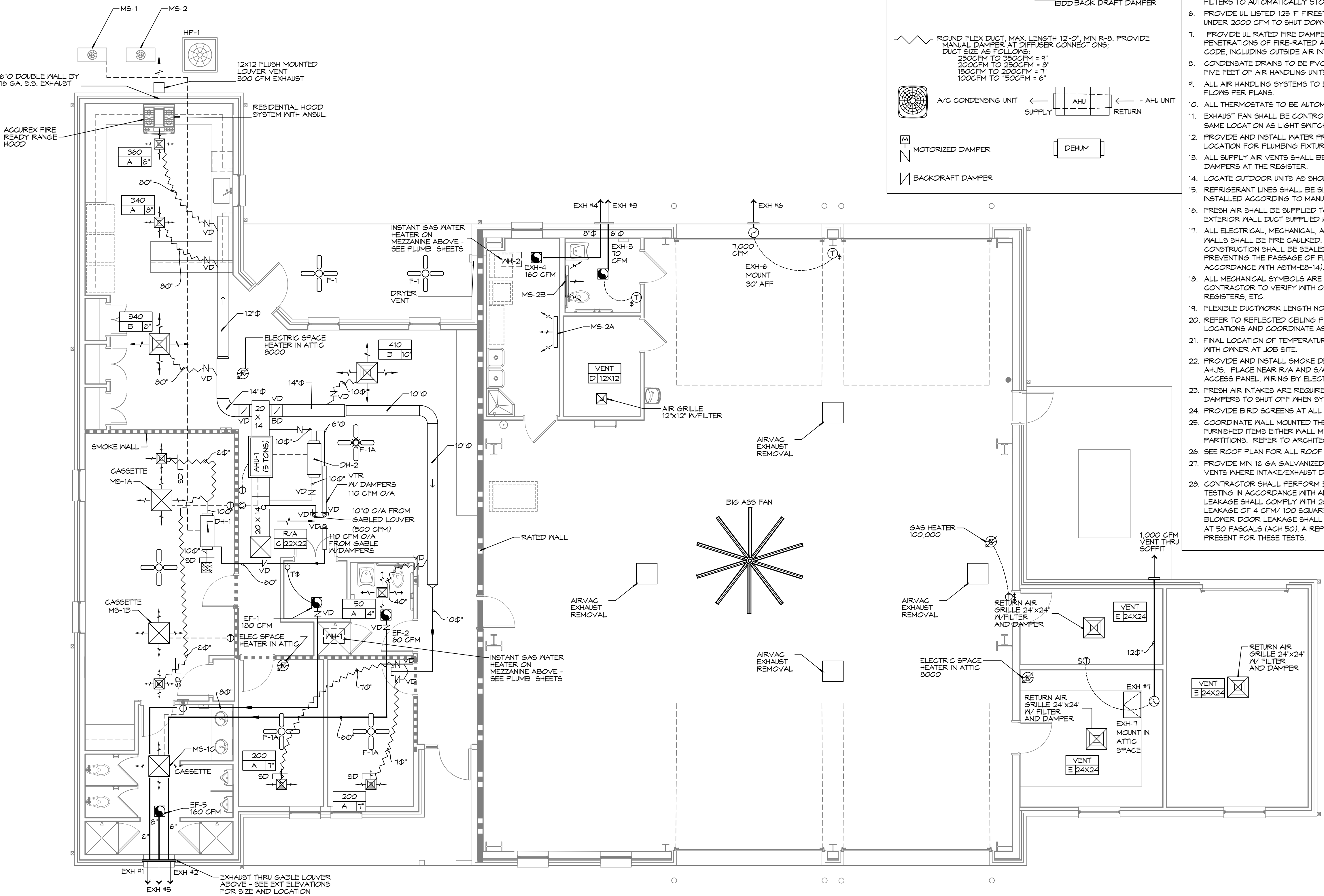

1 MECHANICAL FLOOR PLAN
SCALE: 3/16" = 1'-0"

DRAWN DIAGRAMMATICALLY FOR CLARITY. FIELD VERIFY PLACEMENT OF ALL EQUIPMENT PRIOR TO FABRICATION.

THIS WORK SHALL MEET ALL HVAC CODES
1. 2021 EDITION OF THE IMC
2. 2021 IECC ENERGY CODE

BLOWER DOOR TEST AND DUCK LEAK TEST SHALL BE PERFORMED BY THE CONTRACTOR. A REPRESENTATIVE FROM THE FD1 SHALL BE PRESENT FOR THESE TEST.

#	DESCRIPTION	DATE

SEAL:

NEW FIRE STATION #10
ST. TAMMANY FIRE PROTECTION DISTRICT NO. 1
2146 LAKESHORE VISTA BLVD
SLIDELL, LA 70461
JOB No: 2519 DATE: 12-05-2025
DRAWN BY: CKD CHECKED BY: BAW

SHEET TITLE:
HVAC FLOOR PLAN, DETAILS, AND SCHEDULES
DRAWING NUMBER:
M101
SHEET No: 39 of 37

MIN-SPLIT SCHEDULE

AIR HANDLER							HEAT PUMP							
Tag	Make	Model	Cooling (MBH)	Heating (MBH)	Power		Tag	Make/Model	Model	Cooling (MBH)	Power		MCA	Remarks
					VAC	PH					VAC	PH		
MS-1A	Mitsubishi	SLZ-AF09NL	9	11	208	1	MS-1	Mitsubishi	MXZ-3D24NL	24	208	1	28.7	1, 2
MS-1B	Mitsubishi	SLZ-AF09NL	9	11	208	1								
MS-1C	Mitsubishi	SLZ-AF09NL	9	11	208	1								
MS-2A	Mitsubishi	MSZ-GX09NL	9	9.0	208	1	MS-2	Mitsubishi	MXZ-2D20NL	22	208	1	21.7	1, 3
MS-2B	Mitsubishi	MSZ-GX09NL	9	9.0	208	1								

- NOTES:**
1. Install per Manufacturer's recommendations
 2. Furnish with wired MA wall mount controller, matching grille and condensate pump.
 3. Furnish with MHK-2 wireless controller and condensate pump.

DX SPLIT SYSTEM SCHEDULE

AIR HANDLER										HEAT PUMP											
TAG	MAKE	MODEL	NOMINAL TONS	TOTAL CFM	O/A CFM	COOLING		Motor HP	ESP (" WC)	HEAT (Kw)	POWER			TAG	NOMINAL TONS	MAKE	MODEL	POWER			REMARKS
						TMBH	SBH				VAC	PH	MCA					VAC	PH	MCA	
AHU-1	Trane	5TAMXB0C60	5	1900	500	60	40	1	0.3	7.2	208	1	34	HP-1	5	Trane	5TWV0X60	208	1	37	1, 2

- NOTES:**
1. Provide inlet filter box, single point power connection, expansion valve, time delay relay, condensate overflow switch & programmable 7/24 thermostat.
 2. Cooling capacities to be rated in accordance with AHRI standard 210/290 for ASHRAE standard design weather conditions in New Orleans, LA.

Exhaust Fan Schedule

Tag	Fan				Power			Make / Model	Remarks
	Airflow (CFM)	TSP (" wc)	Amps	Watts	Volts	Phase	Hz		
EF-1	180	0.3		100	120	1	60	Loren Cook GN-542	1, 2
EF-2	50	0.2	0.4		120	1	60	Broan AE80SL	1, 2
EF-3	70	0.2	0.4		120	1	60	Broan AE80SL	1, 2
EF-4	160	0.2	1.5		120	1	60	Broan 503	1, 2
EF-5	160	0.3			120	1	60	Broan 503	1, 2
EF-6	7000	0.1	20		120	1	60	Greenheck AER-20	1, 2, 3
EF-7	1000	0.2		190	120	1	60	Greenheck CSP-A1050QD	1, 2

- NOTES:**
1. Install per Manufacturer's recommendations.
 2. Furnish with matching grille, speed control and backdraft damper.
 3. Aluminum construction w/ weatherhood and motorized damper

EXHAUST REMOVAL SCHEDULE

DESCRIPTION	QUANTITY
AIRVAC 911® EXHAUST REMOVAL SYSTEM - Single Ph. 115V	4
AIRVAC 911® FILTER PACK (4-Stage Filter Pack, "Main Filters")	4
AIRVAC 911® FILTER GAUGE (Min. one per building section)	1
UL 508A CERTIFIED CONTROL PANEL - AVCC-4C	1
ACTIVATION PACKAGE - E-960-D90Q PHOTO EYE (set) & N505AUTM/STX01 (2") TRACK MOUNTED DOOR SWITCH	4
PREFILTERS (12 Per Box/Change date est. indicated below)	1

- NOTE:**
1. ALL FANS INSTALLED IN RATED ASSEMBLIES SHALL BE EQUIPPED W/ APPROPRIATE FIRE DAMPER TO MATCH ASSEMBLY FIRE RATING.
 2. PAINT ALL SHUTTERS AND EXTERIOR GRILLES TO COLOR SPECIFICATION BY ARCHITECT.
 3. PROVIDE BIRSCREENS ON ALL SHUTTERS AND EXTERIOR GRILLES.
 4. PROVIDE BACK FLOW PREVENTER ON ALL EXHAUST SYSTEMS

**BIG ASS FAN;
BIG ASS POWERFOIL F-PFD1-1022534 FAN
WITH DOWNTUBE AND A 1HP MOTOR. MODEL
NUMBER F-PFD1-1022534.**

DEHUMIDIFIER SCHEDULE

TAG	Make	Model	Blower (CFM)	Vent (CFM)	Moisture Removal (Pints)	Power			Remarks
						VAC	Ph	Amps	
DH-1	Santa-Fe	V125	350	110	125	120	1	10.2	1
DH-2	Santa-Fe	V125	350	110	125	120	1	10.2	1

- NOTES:**
1. Install units in accordance with manufacturer's recommendations.

DIFFUSER SCHEDULE

TAG	SERVICE	NECK SIZE	DESCRIPTION	REMARKS
A	Supply Air	Ref. Plan	20" x 20" Adjustable Square Cone Diffuser, Price ASCDA w/ Insulated Back Panel	1, 2, 3
B	Supply Air	Ref. Plan	24" x 24" Adjustable Square Cone Diffuser, Price ASCDA w/ Insulated Back Panel	1, 2, 3
C	Return Air	Ref. Plan	24" X 24" Perforated, Ducted Return, Titus PAR	1, 2, 3
D	Vent	N/A	12" x 12" filter return air grille, Price 60FH w/ 1" filter media	1, 3
E	Vent	N/A	24" x 24" filter return air grille, Price 60FH w/ 1" filter media	1, 3

- Notes:**
1. Seal perimeter of diffusers/grilles to prevent moisture migration from attic space, as applicable
 2. R value of insulated back panels/plenums to exceed R-8
 3. Coordinate with owner / architect for color and finish

WATER HEATER SCHEDULE

TAG	Type	Make	Model	Range of Flow (GPM)	Temperature Rise (F)	Natural Gas		Power			Remarks
						Maximum (MBH)	FT3/Hr.	VAC	Ph	Amps	
WH-1	Instant, Noncondensing	Rinnai	RE1991	0.13 -9.8	35	199	193	120	1	4	1

- NOTES:**
1. Install units in accordance with NFPA and manufacturer's recommendations.

GENERAL HVAC NOTES

1. ALL MECHANICAL WORK SHALL BE COORDINATED WITH THE WORK OF OTHER TRADES.
2. VERIFY ROUTING OF ALL WORK ON SITE.
3. HVAC CONTRACTOR REPLACE ALL EQUIPMENT FILTERS AT THE TIME OF POSSESSION OF THE PROJECT BY THE OWNER, USING ONLY NEW FILTERS OF THE PROPER SIZE AND TYPE.
4. CONTRACTOR SHALL LEAVE THE HVAC SYSTEM IN PROPER WORKING ORDER AND SHALL GUARANTEE SAME FOR A PERIOD OF TWELVE (12) MONTHS FROM THE DATE OF SUBSTANTIAL COMPLETION.
5. PROVIDE A MINIMUM 4" THICK LEVEL PRE-CAST CONCRETE PAD FOR PACKAGED UNITS AT GRADE. THE SIZE OF THE PRE-CAST PAD WILL BE REQUIRED TO ACCOMMODATE THE FOOT PRINT OF THE UNIT AND BE ACCEPTABLE FOR MOUNTING.
6. WHERE MOUNTING HEIGHTS ARE NOT INDICATED OR DIMENSIONED, INSTALL MECHANICAL SERVICES AND OVERHEAD EQUIPMENT TO PROVIDE THE MAXIMUM HEADROOM POSSIBLE.

DAMMON ENGINEERING, INC.
LOUISIANA & MISSISSIPPI
Chief Engineer: Brian Mistich, PE
554 Old Spanish Trail
Slidell, LA 70458
www.dammonengineering.com
info@dammonengineering.com
PH: 985-649-5832

#	DESCRIPTION	DATE

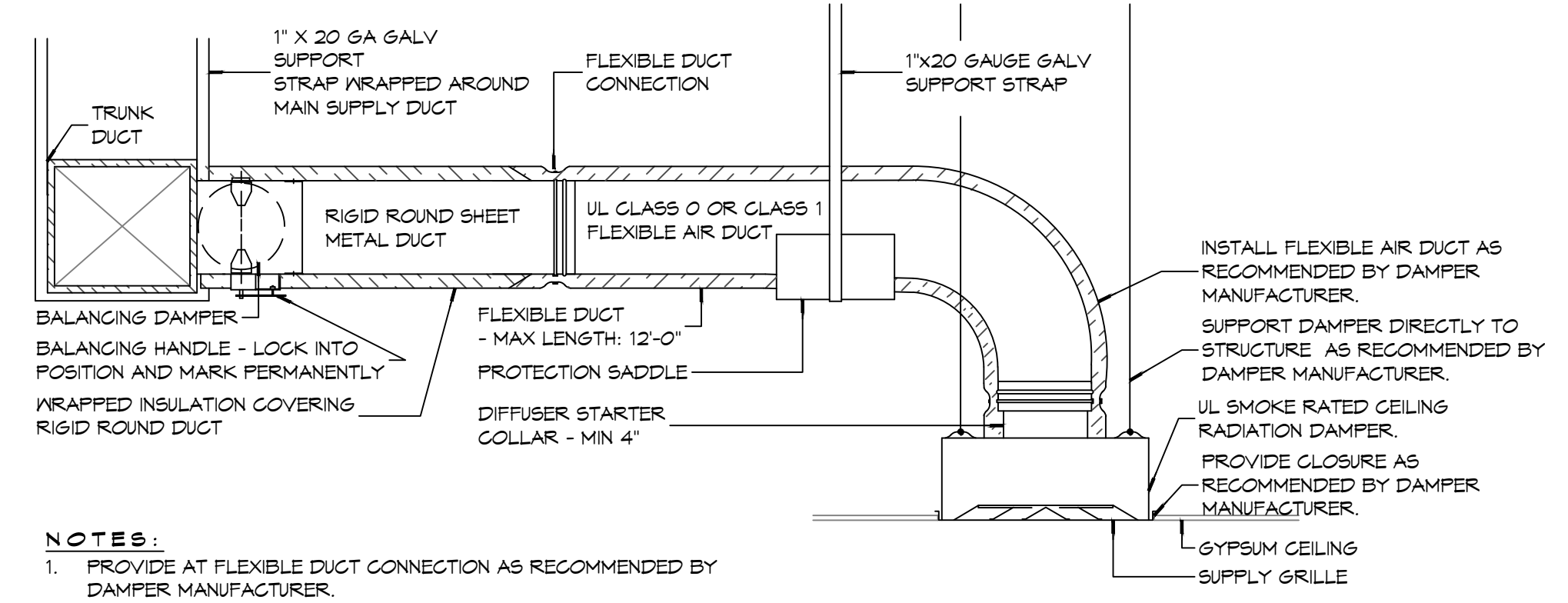

- NOTES:**
1. PROVIDE AT FLEXIBLE DUCT CONNECTION AS RECOMMENDED BY DAMPER MANUFACTURER.
 2. PROVIDE MINIMUM 4" COLLARS FOR ATTACHMENT OF THE FLEXIBLE DUCT TO ROUND DUCT, DAMPERS AND DIFFUSERS.
 3. BAND RIGID ROUND DUCT INSULATION TO DUCT AND PROVIDE TAPE FOR INSULATION OVERLAP.

(B) TYPICAL FIRE/SMOKE RATED CEILING DIFFUSER

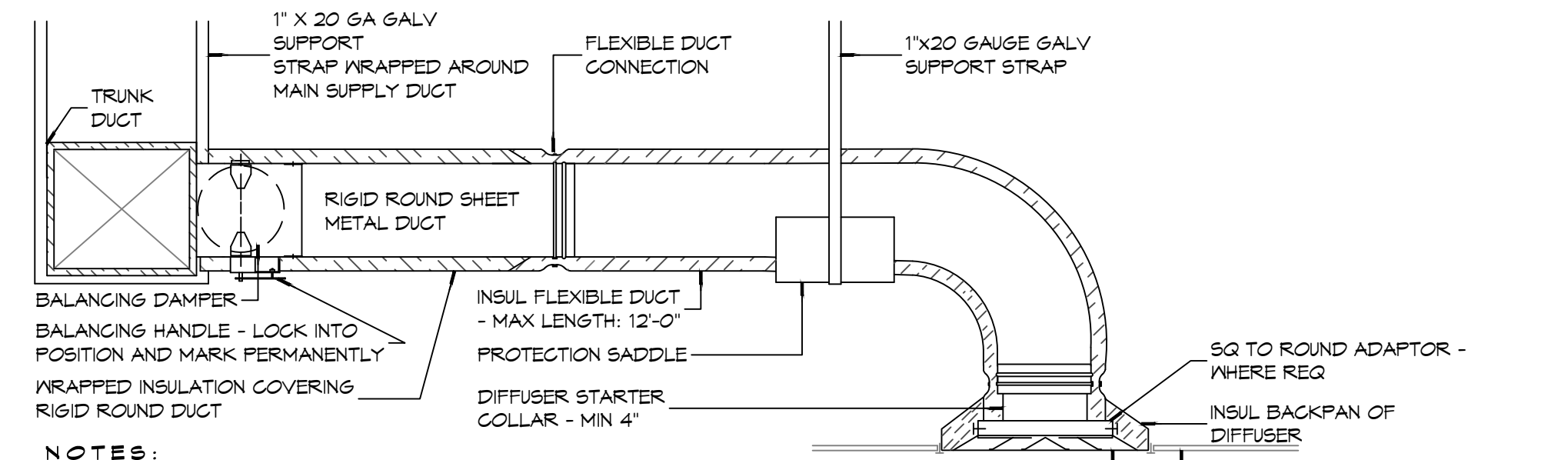

- NOTES:**
1. PROVIDE AT FLEXIBLE DUCT CONNECTION "PANDUIT" DRAWBAND ON THE INTERIOR FLEXIBLE DUCT HELIX.
 2. PROVIDE MINIMUM 4" COLLARS FOR ATTACHMENT OF THE FLEXIBLE DUCT TO ROUND DUCT, DAMPERS AND DIFFUSERS.
 3. BAND RIGID ROUND DUCT INSULATION TO DUCT AND PROVIDE TAPE FOR INSULATION OVERLAP.

(A) TYPICAL NON-RATED CEILING DIFFUSER

**NEW FIRE STATION #10
ST. TAMMANY FIRE PROTECTION
DISTRICT No. 1**
248 LAKESHORE VISTA BLVD
SLIDELL, LA 70461
JOB No: 2519 DATE: 12-05-2025
DRAWN BY: CKD CHECKED BY: BAK

SHEET TITLE:
HVAC DETAILS AND SCHEDULES
DRAWING NUMBER:
M102
SHEET No: 34 of 37

DATE: 05/14/2025 11:42:52 AM
PROJECT: 248 LAKESHORE VISTA BLVD
DRAWN BY: GKD
CHECKED BY: GKD
DATE: 12-05-2025
JOB NO: 2519
SHEET TITLE: POWER PLAN
DRAWING NUMBER: E101

CONDUIT TO JUNCTION BOX
FLASHING ALARM LIGHT
WEATHERPROOF LOCKABLE CONTROL BOX
100/240V/10 30AMP FUSE PER MANUFACTURER'S INSTRUCTIONS
2" POWER CONDUIT TO LIFT STATION
CONDUIT TO LIFT STATION

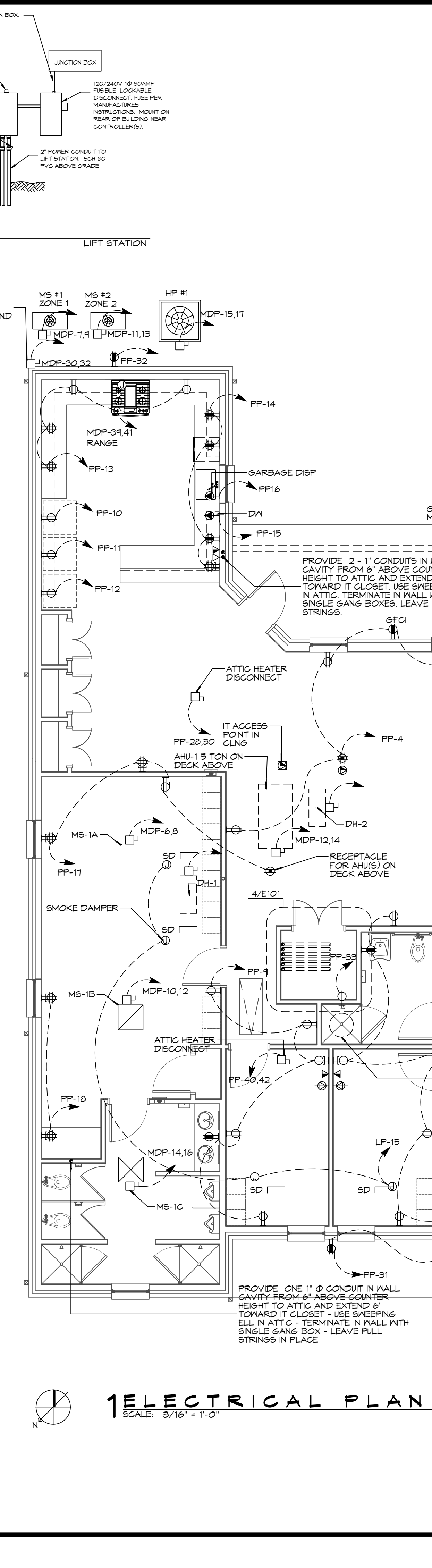
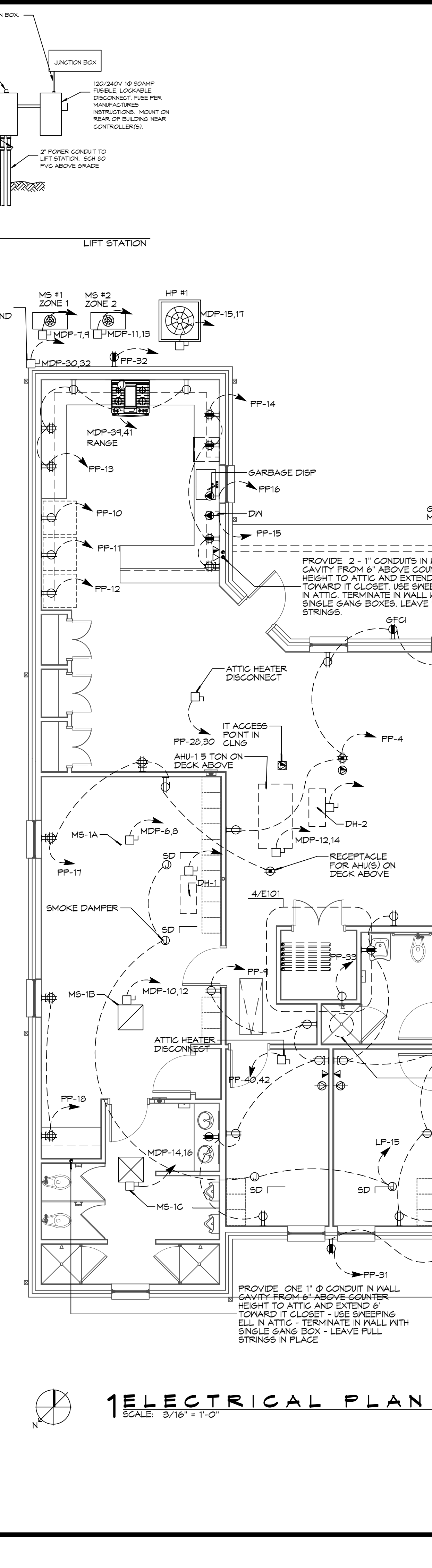
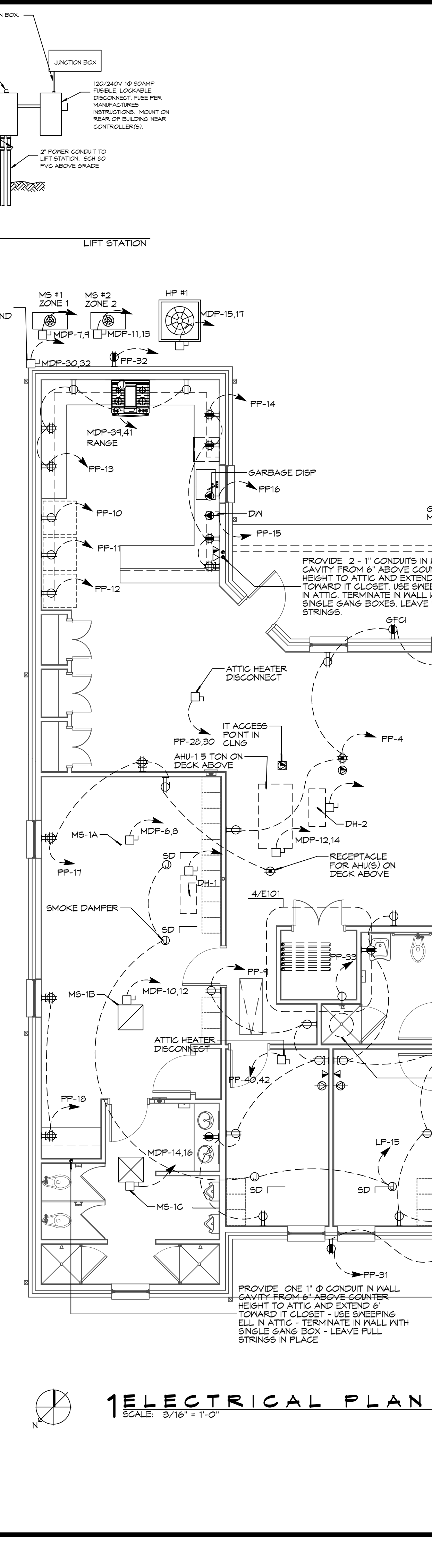
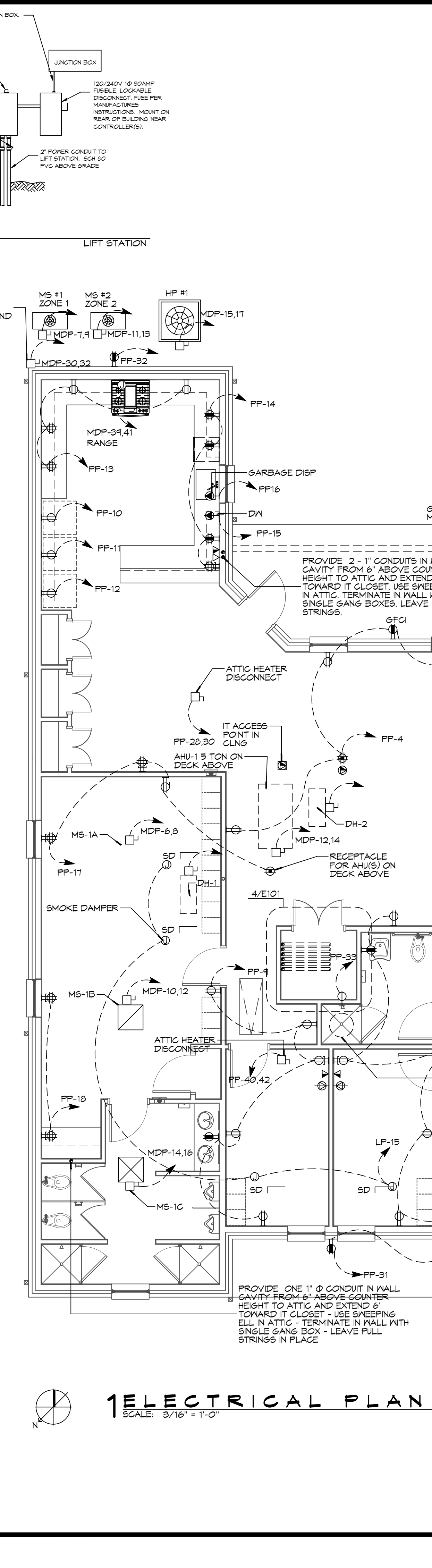
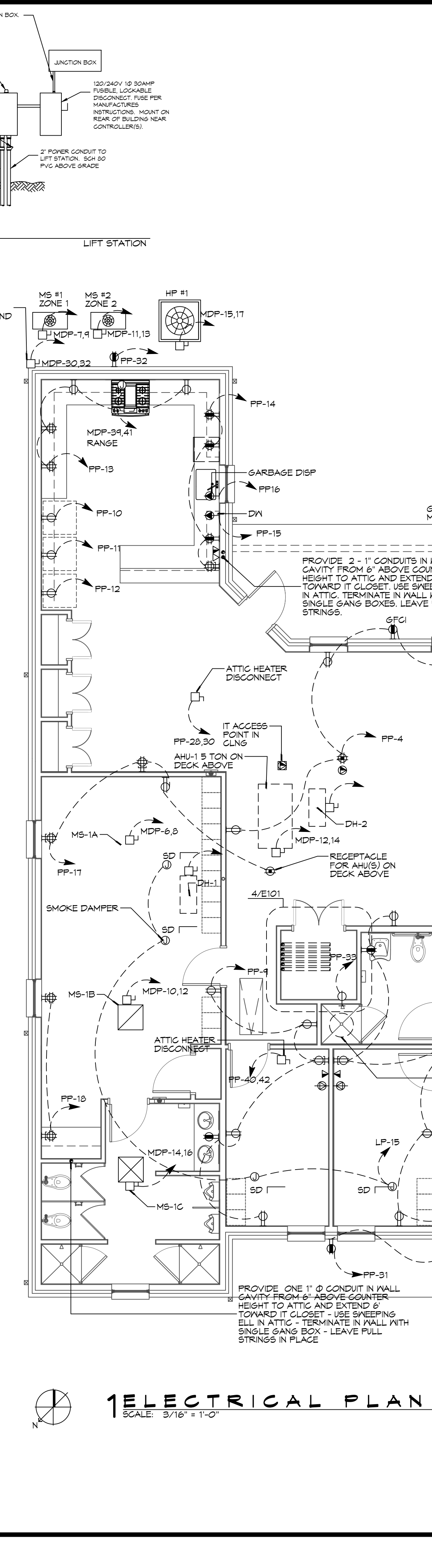
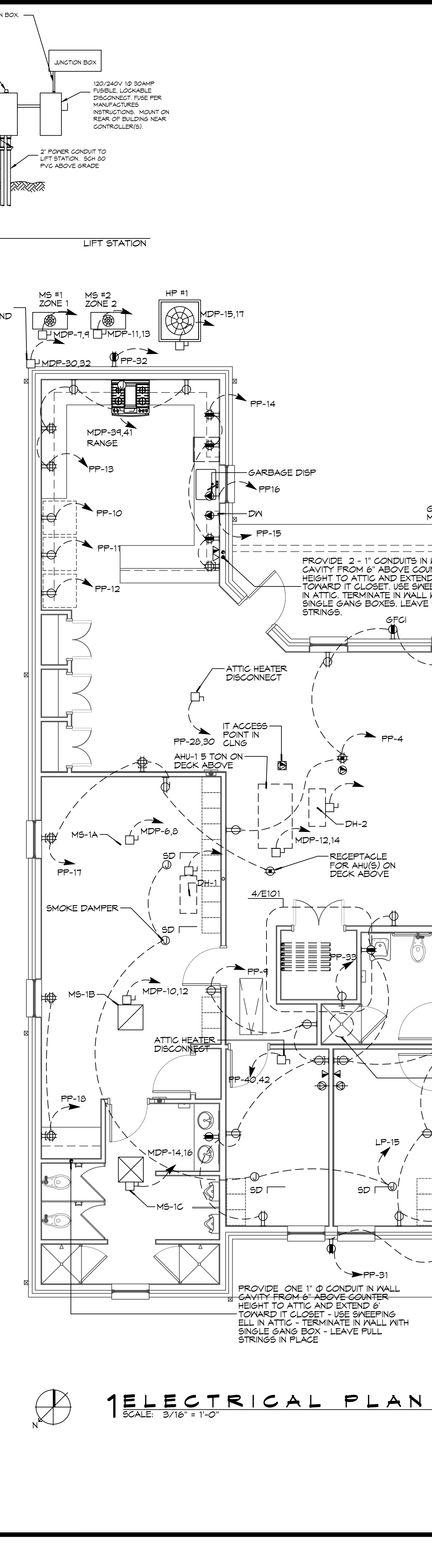
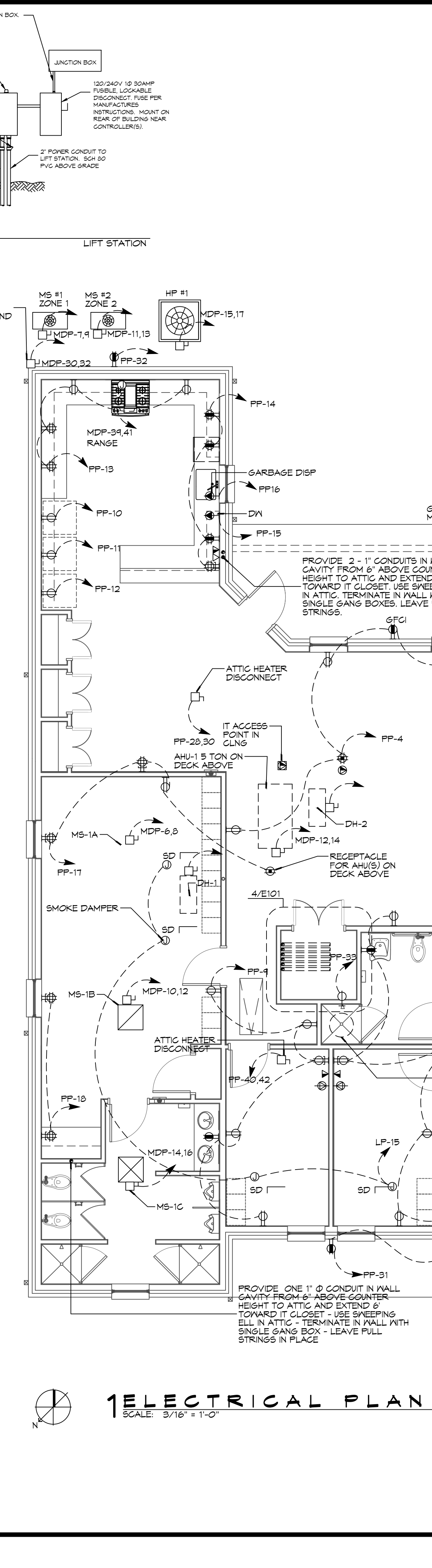
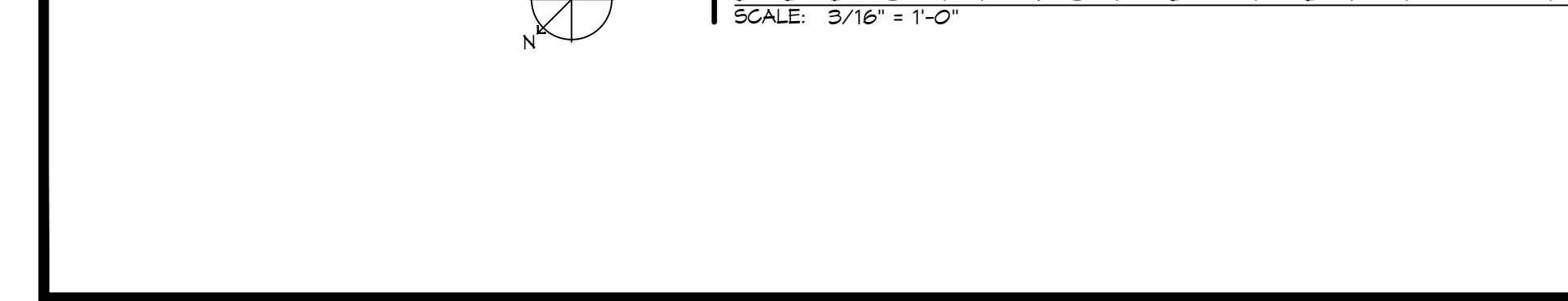
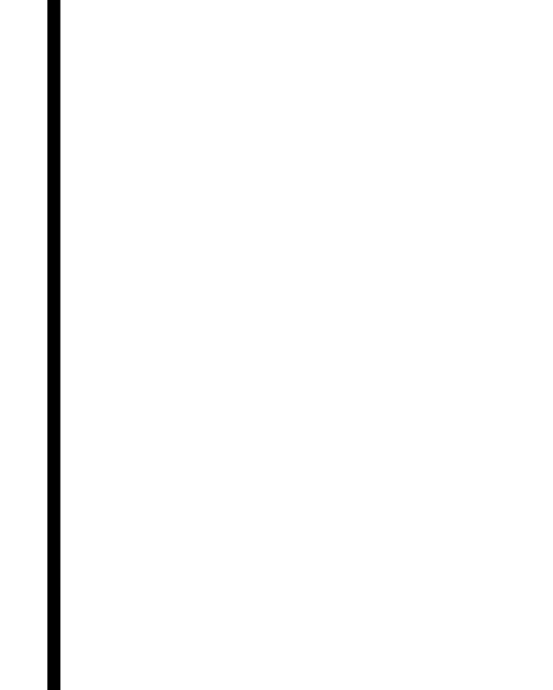
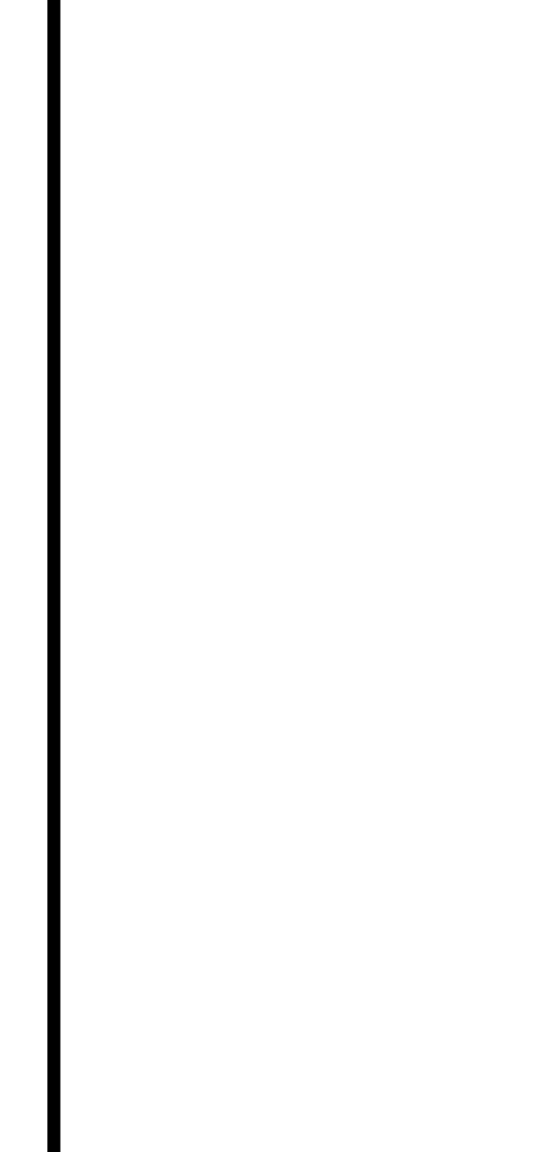

248 LAKESHORE VISTA BLVD
ST. TAMMANY FIRE PROTECTION DISTRICT NO. 1
SHEET TITLE: POWER PLAN
DRAWING NUMBER: E101

DATE: 12-05-2025
JOB NO: 2519
DRAWN BY: GKD
CHECKED BY: GKD

SHEET No: 35 of 37



DAMMON ENGINEERING, INC.
LOUISIANA & MISSISSIPPI
www.dammonengineering.com
504.916.5332
info@dammonengineering.com
PH: 985.649.5832

LUMINAIR SCHEDULE

ID	DESCRIPTION	MOUNTING	MFR	PART #	FINISH	LAMPS #	LAMP TYPE	WATTAGE	FIXTURE NOTES	INSTALLATION NOTES
EM-1	EMERGENCY LIGHT	WALL	PHILIPS	F1W1C	WHITE	2	35W MR16	2.5W		
EM-2	EMERGENCY LIGHT	WALL	BARRON	LL60	BLACK	2	HIT	10.8W		
EX-1	EXIT LIGHT	CEILING	PHILIPS	45VLRICALM	WHITE	1	LED	2.5W		
EX-2	EXIT LIGHT	WALL	PHILIPS	CXL36W	WHITE	1	LED	3.7W		
F-1	CEILING FAN	CEILING	MODERN FAN COMPANY	IND-6V525VNLNC	GALV	0	N/A	25W		
F-1A	CEILING FAN W/ LIGHT	CEILING	MODERN FAN COMPANY	IND-6V525V48INC	GALV	1	75W 64 HALOGEN	160W		
L-1	LINEAR FLUORESCENT	SURFACE	LITHONIA LIGHTING	AVSM 2 54T8HO SBL DLS MVOLT	WHITE	2	T8	54W		
L-10	PENDANT	RECESSED	COOPER INDUSTRIES	P461-071	CHROME	1	60W T10 MED BASE	60W	CLEAR BULB	
L-11	PENDANT	RECESSED	COOPER INDUSTRIES	P460-071	CHROME	1	60W T10 MED BASE	60W	CLEAR BULB	
L-12	WALL SCONCE	WALL	PHILIPS	106L-2-39LA-NH-UNV-BRP	PAINTED		LED			SEE EXT ELEV FOR MOUNTING HT
L-13	WALL SCONCE	WALL	PHILIPS	RIN-100-IN-S-C-1-RB6NH	COLOR TBD	1	LED	100	SIZE 2	SEE EXT ELEV FOR MOUNTING HT
L-14	VAPORPROOF FIXTURE	WALL	TEXAS FLUORESCENTS	VPMINGSL	METAL	1	A19 T5W SOFT WHITE	75W		
L-2	RECESSED CAN	RECESSED	COOPER INDUSTRIES	HTICAT	WHITE	1	UTILITEC PRO LPAR30/5K/LED65	20W	WHITE BAFFLE AND TRIM	
L-3	HIGH BAY LIGHT	PENDANT	TEXAS FLUORESCENTS	HBC432M23MY	-	4	48" T8	25W		
L-4	VAPORPROOF FIXTURE	CEILING	TEXAS FLUORESCENTS	VPCINGSL	METAL	1	A19 T5W SOFT WHITE	75W		
L-5	VANITY LIGHT	WALL	NUVO LIGHTING	60-906	BRUSHED NICKEL	2	F1T8	17W		SEE INT ELEV
L-6	RECESSED CAN	RECESSED	COOPER INDUSTRIES	HTICAT	WHITE	1	UTILITEC PRO LPAR30/5K/LED65	20W	VAPOR PROOF COVER	
L-7	SURFACE FLUORESCENT	CEILING	TEXAS FLUORESCENTS	SHUCPF232MY	WHITE	2	F32T8	64W		
L-8	OUTDOOR LIGHT	GROUND	UNIVERSAL LIGHTING SYSTEMS	UC1300AZ	ALUM/BRONZE	1	MR16LED 40"	7W		MNT IN CONC
L-9	FLUORESCENT STRIP	CEILING	LITHONIA	LEBL4 LP835	WHITE	2	LED	7W		

GENERAL LIGHTING NOTES

- ALL WORK SHALL COMPLY WITH APPLICABLE NATIONAL, STATE, AND LOCAL CODES, RULES, REGULATIONS, AND REQUIREMENTS OF THE SERVICE UTILITY COMPANY.
- GENERAL CONTRACTOR SHALL NOTIFY THE ARCHITECT IMMEDIATELY IF ANY CONFLICTS OCCUR BETWEEN LIGHTING AND ANY OTHER TRADE. DO NOT PROCEED WITH INSTALLATION IN THAT AREA UNTIL CONFLICT HAS BEEN RESOLVED TO THE SATISFACTION OF THE ARCHITECT AND ENGINEER.
- REFER TO ARCHITECTURAL DRAWINGS FOR EXACT LOCATION AND MOUNTING INSTRUCTIONS FOR ALL LIGHT FIXTURES. NOTIFY THE ARCHITECT AND ENGINEER OF ANY DISCREPANCIES BETWEEN THESE PLANS AND THE ARCHITECTURAL PLANS RELATING TO QUANTITY, TYPE AND LOCATION OF DEVICES AND/OR FIXTURES.
- WHEN SPECIFIC LIGHT FIXTURE HAS BEEN SPECIFIED IN THE FIXTURE SCHEDULE, ELECTRICAL SHALL PROVIDE COMPLETE ASSEMBLY INCLUSIVE ALL PARTS AND HARDWARE TO INSURE PROPER FUNCTIONING FIXTURE.
- ALL CONDUCTORS SHALL BE #12 AWG UNLESS NOTED OTHERWISE.
- ALL 120V RUNS LONGER THAN 60 FEET SHALL BE #10 AWG AND 277V RUNS LONGER THAN 150 FEET SHALL BE #10 AWG UNLESS NOTED OTHERWISE.
- ALL CONDUCTORS SHALL BE COPPER.
- WHERE CONDUCTOR SIZES ARE NOTED ON DRAWINGS, THAT WIRE SIZE SHALL BE THROUGH THE ENTIRE RUN UNLESS OTHERWISE NOTED.
- MOUNTED LIGHT SWITCHES 48" AFF UNLESS NOTED OTHERWISE ON ARCHITECTURAL DRAWINGS.
- ALL GANGED SWITCHES SHALL HAVE A COMMON SEAMLESS FACEPLATE. EACH MULTI-GANGED BOX SHALL BE NO MORE THAN SIX (6) SWITCHES WIDE. WHERE MORE THAN SIX (6) SWITCHES ARE SHOWN AT ONE (1) LOCATION, ADDITIONAL MULTI-GANGED BOXES SHALL BE STACKED VERTICALLY AND THE WIDTH OF THE MULTI-GANGED SHALL BE AS EVEN AS POSSIBLE.
- EACH DIMMER SWITCH SHALL HAVE A WATTING RATING 25% HIGHER THAN THE TOTAL WATTAGE OF ALL LIGHTS TO BE CONTROLLED BY THE DIMMER. DIMMER SIZES 600, 1000, 1500, AND 2000 WATTS, LUTRON NOVA T-STAR. WHERE SWITCHES ARE GANGED WITH DIMMERS, THE SWITCHES SHALL ALSO BE LUTRON NOVA T-STAR, FLUORESCENT AND LOW VOLTAGE DIMMERS SHALL BE LUTRON NOVA T-STAR.
- WHERE FLUORESCENT FIXTURES ARE SHOWN TO BE DIMMED, THE FIXTURES SHALL HAVE DIMMING TYPE BALLASTS WHICH ARE COMPATIBLE WITH THE SPECIFIED DIMMERS.
- WHERE LED FIXTURES/LAMPS ARE SHOWN TO BE DIMMED, THE DIMMER SHALL BE COMPATIBLE WITH THE FIXTURE/LAMP SPECIFIED OR PROVIDED.
- ALL EMERGENCY LIGHT FIXTURES SHALL HAVE 90 MINUTE BATTERY BACKUP WITH INTEGRAL TEST BUTTON AND SHALL BURN CONTINUOUSLY.
- ALL FLUORESCENT FIXTURES THAT UTILIZE DOUBLE-ENDED LAMPS AND CONTAIN BALLASTS SHALL BE PROVIDED WITH A DISCONNECTING MEANS IN ACCORDANCE WITH NEC 410.73G.

LEGEND

	EMERGENCY LIGHT FIXTURE		ELECTRIC PANEL BOARD
	EXIT LIGHT FIXTURE - WALL MOUNTED		CIRCUIT HOME RUN
	EXIT LIGHT FIXTURE - CEILING MOUNTED		WALL MTD SPEAKER - PROVIDE RATED HOUSING FOR RATED WALLS WHERE INDICATED
	CEILING FAN		CEILING MTD SPEAKER - PROVIDE RATED HOUSING FOR RATED CEILING WHERE INDICATED
	CEILING MTD FLOOR STRIP FIXTURE		EXTEND TO FIXTURE(S) NOT SHOWN - SEE NOTE
	RECESSED CEILING LIGHT FIXTURE		LIGHT SWITCH 120V COMMERCIAL GRADE
	CEILING HUNG FLOOR STRIP FIXTURE		LIGHT SWITCH - 3-WAY 120V COMMERCIAL GRADE
	SURFACE MOUNTED LIGHT FIXTURE		LIGHT SWITCH - DIMMER 120V COMMERCIAL GRADE
	WALL MOUNTED LIGHT FIXTURE		PROVIDED BY M.C.
	CEILING MTD FLOOR FIXTURE		
	OUTDOOR LIGHT ON PHOTO TIMER- MTD IN GROUND		
	PENDANT LIGHT FIXTURE		
	EXHAUST FAN - SEE MECH		

ELECTRICAL LOAD SUMMARY

WASHINGTON/ST. TAMMANY POWER COMPANY	
PROJECT NAME:	FIRE DISTRICT #1 FIRE STATION 10
PROJECT ADDRESS:	2145 LAKESHORE VISTA BLVD
CITY/TOWN:	SLIDELL, LOUISIANA
INTENDED USER:	FIRE STATION
REQ SERV:	120 / 240 V 1Ø PHASE 3 WIRES
SERV ENTR SIZE:	400 AMPS
HVAC TONNAGE:	10.5 TONS
LARGEST MOTOR:	N/A HP
TOTAL BUILDING SQ FT:	6526 SF
INDIVIDUAL UNIT SQUARE FOOTAGE:	N/A SF (MULT OCCUPANCY)
INDIVIDUAL UNIT DESIGNATION:	N/A (MULT OCCUPANCY)
LOAD SOURCE	
BUILDING LIGHTING	9.0
ELECTRIC WATER HEATING	18.0
HEAT PUMPS	-
SUPPLEMENTAL HEAT SYSTEMS	-
AIR COND CONDENSING UNITS	11.6
ELEC HEATING (PRIMARY) - AHU'S	27.8
COOKING	12.2
REFRIGERATION	3.9
RECEPTACLES (STANDARD)	20.1
RECEPTACLES (COMPUTER)	2.0
TOTAL MOTORS (EXCLUDE HVAC)	12.2
EXTERIOR LIGHTING	29.0
MISCELLANEOUS - CEILING FANS	0.2
OTHER (SPECIFY)	4.5

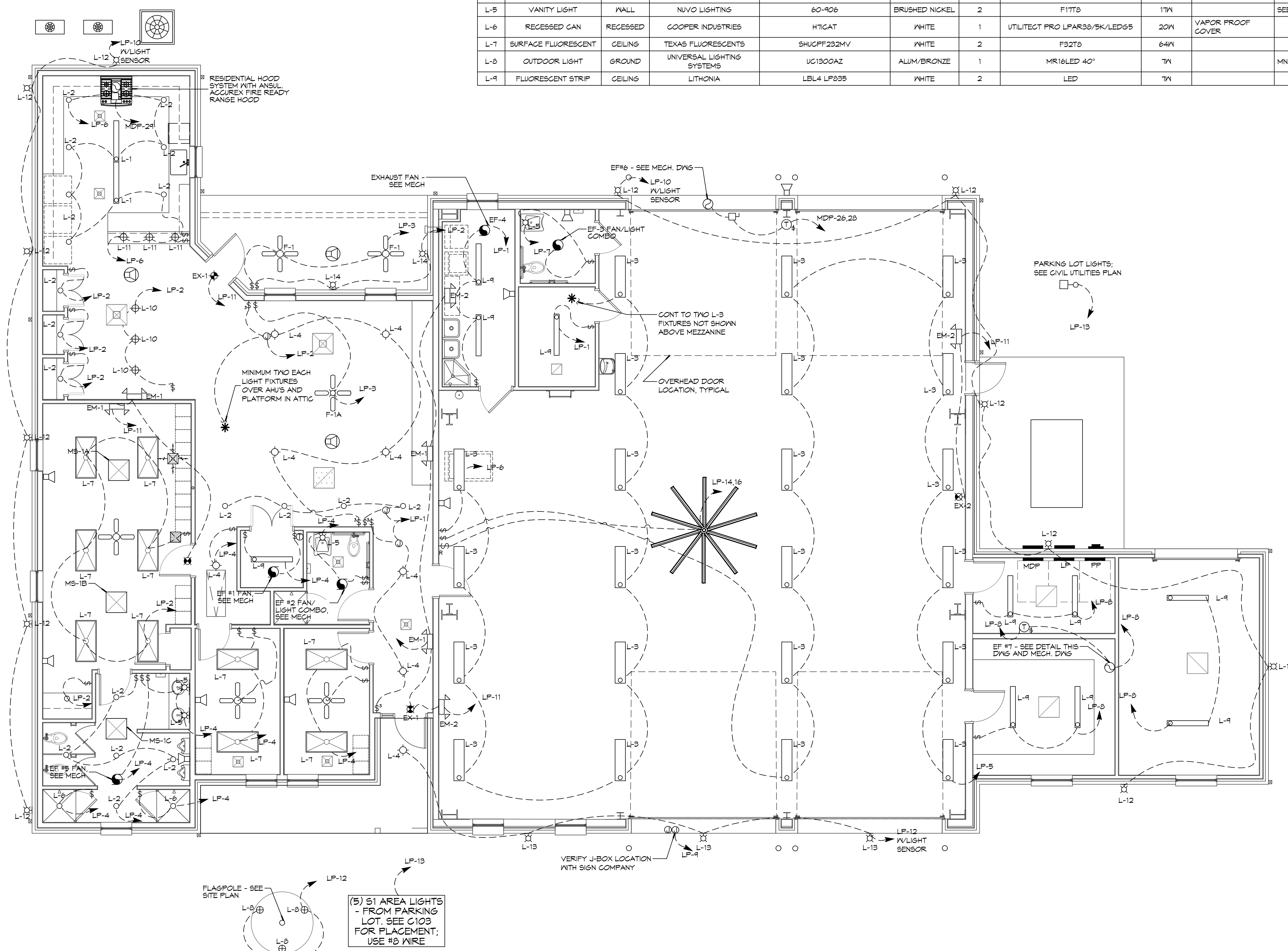

1 ELECTRICAL PLAN - LIGHTING
SCALE: 3/16" = 1'-0"

DAMMON ENGINEERING, INC.
LOUISIANA & MISSISSIPPI
www.dammonengineering.com
info@dammonengineering.com
PH: 985.649.5832

Chief Engineer: Brian M. Misch, PE
554 Old Spanish Trail
Slidell, LA 70458

REVISIONS	DATE
1	5-XX-2015



NEW FIRE STATION #10
ST. TAMMANY FIRE PROTECTION DISTRICT NO. 1

2145 LAKESHORE VISTA BLVD
SLIDELL, LA 70461

JOB No: 2519 DATE: 12-05-2025
DRAWN BY: CKD CHECKED BY: BAK

SHEET TITLE:
ELECTRICAL PLAN - LIGHTING AND LOAD SUMMARY

DRAWING NUMBER:
E102

SHEET No: 36 of 37

PANEL: MDP
 LOCATION: ELECTRICAL CLOSET
 FEEDER SOURCE: GLECO

VOLTAGE: 120/240V, 400 AMP 1Ø, 3Ø
 ENCLOSURE: SURFACE MOUNTED, NEMA 1 PANELBOARD
 W/EQUIPMENT GND BAR, MLO, 22000 AIC

CKT. NO.	THHN WIRE SIZE	LOAD DESCRIPTION LOCATION	BREAKER		LOAD (VA)	AØ	BØ	LOAD (VA)	BREAKER		LOAD DESCRIPTION LOCATION	THHN WIRE SIZE	CKT. NO.
			AMP	POLE					POLE	AMP			
1	4/0	SUB-PANEL "PP" 200 AMPS	200	2	18,410			9,716	2	200	SUB-PANEL "LP" 200 AMPS	4/0	2
3					17,270			8,030	2				4
5	#6	MS-#1 ** 2 TON	50	2	3,444			104	2	15	MS-1A ** 3/4 TON	#12	6
7					3,444			104	2				8
9	#8	MS-#2 ** 1.6 TON	40	2	2,257			104	2	15	MS-1B ** 3/4 TON	#12	10
11					2,257			104	2				12
13	#6	HP-#1 ** 5 TON	50	2	3,120			104	2	15	MS-1C ** 3/4 TON	#12	14
15					3,120			104	2				16
17		AHU # 1 ** 5 TON, 1.5 KW HEAT	45	2	3,536			104	2	15	MS-2A ** 1.6 TON	-	18
19					3,536			104	2			#12	20
21	#12	AIRVAC EXHAUST REMOVAL #1	20	1	1,587			104	2	15	MS-2B ** 1.6 TON	#12	22
23	#12	AIRVAC EXHAUST REMOVAL #2	20	1	1,587			104	2				24
25	#12	AIRVAC EXHAUST REMOVAL #3	20	1	1,587			828	2	15	EXHAUST FAN #7 MAINTENANCE BAY 3/4 HP MOTOR	#8	26
27	#12	AIRVAC EXHAUST REMOVAL #4	20	1	1,587			828	2				28
29	#12	ACCUREX FIRE READY RANGE HOOD	20	1	1,500			2,760	2	30	SANITARY SEWER LIFT STATION **	#10	30
31		SPARE	20	1	805			2,760	2				32
33		SPARE	20	1	180			-	1	20	SPARE		34
35		SPACE	-	1	-			1,150	1	15	LAUNDRY GAS DRYER LOCATED IN UTILITY ROOM 118	#12	36
37		SPACE	-	1	-			1,000	1	20	WASHING MACHINE UTILITY ROOM 118	#12	38
39	#6	JUNCTION BOX FOR RANGE LOCATED IN KITCHEN 108	50	2	4,800			1,000	1	20	GEAR WASHING MACHINE APPARATUS BAY	#12	40
41					4,800			-	1	-	SPACE	-	42
					TOTAL CONNECTED LOAD (VA) = 91,143								
					AØ = 49,871		BØ = 47,266						

NOTE: ** - INSTALL BREAKER TO MATCH UNIT THAT IS INSTALLED BY MECHANICAL CONTRACTOR.

PANEL: LP
 LOCATION: ELECTRICAL CLOSET
 FEEDER SOURCE: MDP PANEL

VOLTAGE: 120/240V, 200 AMP 1Ø, 3Ø
 ENCLOSURE: SURFACE MOUNTED, NEMA 1 PANELBOARD
 W/EQUIPMENT GND BAR, MLO, 22000 AIC

CKT. NO.	THHN WIRE SIZE	LOAD DESCRIPTION LOCATION	BREAKER		LOAD (VA)	AØ	BØ	LOAD (VA)	BREAKER		LOAD DESCRIPTION LOCATION	THHN WIRE SIZE	CKT. NO.
			AMP	POLE					POLE	AMP			
1	#12	LIGHTS IN ENTRY 101 & DAYRM 102, UTILITY RM 118, STORAGE RM 120	20	1	476			1386	1	20	LIGHTS IN DAYRM 102, DINING RM 109, ATTIC FOR AHUS, PANTRIES 110, 111, 112 & BUNK 113	#12	2
3	#12	CEILING FANS IN DAYROOM 102 AND ON EXTERIOR REAR PATIO	20	1	855			1087	1	20	LIGHTS IN CAPT RM 103, MEN & WOMEN TOILET ANTE ROOM 106, & CAPT ROOM 107 & IT CLOSET	#12	4
5	#12	LIGHTS IN APPARATUS BAY 111	20	1	1752			1752	1	20	LIGHTS IN KITCHEN	#12	6
7	#12	RESTRM 119 LIGHTS, FAN AND HEATER	20	1	1750			732	1	20	LIGHTS GEAR RM 122, MECH RM 123, & STORAGE 2 RM 124	#12	8
9	#12	DOUBLE JUNCTION BOXES FOR SIGNS ON BLDG. ABOVE APPARATUS BAY DOORS	20	1	1800			1,200	1	20	WEST AND SOUTH EXTERIOR WALL-PACK LED LIGHTS, PROVIDE PHOTOCELL	#12	10
11	#12	EXIT AND EMERGENCY LIGHTS	20	1	320			526	1	20	FRNT EXTERIOR WALL-MOUNTED LIGHTS, FRNT PORCH/ALCOVE LIGHT & FLAGPOLE LIGHTS, PROVIDE PHOTOCELL	#12	12
13	#8	EXTERIOR PARKING LIGHTS	20	1	450			960	1	15	BIG ASS FAN IN APPARATUS BAY, RM 117	#12	14
15	#12	HVAC SMOKE DAMPERS	20	1	1800			960	1	20	SPARE	#12	16
17	#12	SPARE	20	1	-			-	1	20	SPARE	#12	18
19	#12	SPARE	20	1	-			-	1	20	SPARE	#12	20
21	#12	SPARE	20	1	-			-	1	20	SPARE	#12	22
23	#12	SPARE	20	1	-			-	1	20	SPARE	#12	24
					TOTAL CONNECTED LOAD (VA) = 17,806								
					AØ = 9,716		BØ = 8,030						

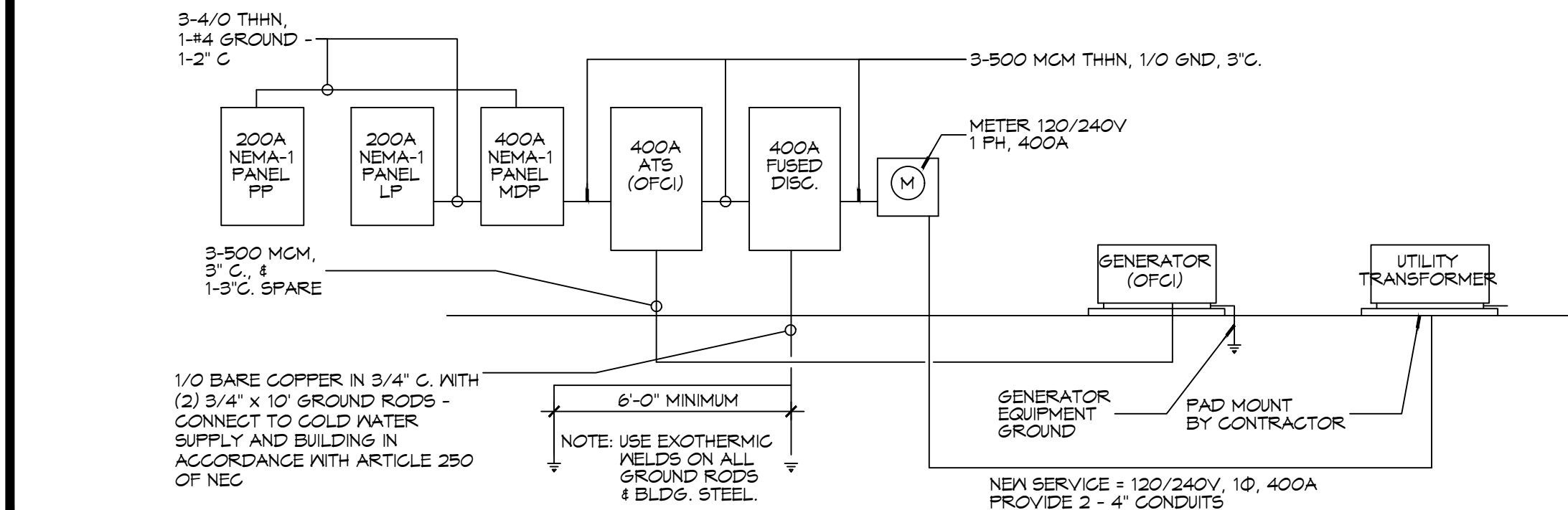

ONE-LINE DIAGRAM
 SCALE: NTS

PANEL: PP
 LOCATION: ELECTRICAL CLOSET
 FEEDER SOURCE: MDP PANEL

VOLTAGE: 120/240V, 200 AMP 1Ø, 3Ø
 ENCLOSURE: SURFACE MOUNTED, NEMA 1 PANELBOARD
 W/EQUIPMENT GND BAR, MLO, 22000 AIC

CKT. NO.	THHN WIRE SIZE	LOAD DESCRIPTION LOCATION	BREAKER		LOAD (VA)	AØ	BØ	LOAD (VA)	BREAKER		LOAD DESCRIPTION LOCATION	THHN WIRE SIZE	CKT. NO.
			AMP	POLE					POLE	AMP			
1	#12	IGNITER FOR AEROTHERM GAS HEATER LOCATED IN CORNER OF APPARATUS BAY	20	1	560			-	1	20	SPARE	#12	2
3	#12	ENTRY 101, DAYROOM 102, CAPTAIN 103, & WOMENS TOILET 104 RECEPTACLES	20	1	1440			1260	1	20	RECEPTACLES FOR DAYROOM 102 & KP GFCI,	#12	4
5	#12	I.T. ROOM 105 DEDICATED RECEPTACLE	20	1	180			1440	1	20	I.T. ROOM 105 QUAD RECEPTACLES	#12	6
7	#12	I.T. ROOM 105 DEDICATED RECEPTACLE	20	1	180			180	1	20	I.T. ROOM 105 DEDICATED RECEPTACLE	#12	8
9	#12	ANTE ROOM 106, CAPTAIN 107, BUNKROOM 113, & MENS TOILET 114 RECEPTACLES	20	1	1260			1100	1	20	KITCHEN 108 DEDICATED REFRIGERATOR RECEPTACLE	#12	10
11	#12	KITCHEN 108 DEDICATED REFRIGERATOR RECEPTACLE	20	1	1100			1100	1	20	KITCHEN 108 DEDICATED REFRIGERATOR RECEPTACLE	#12	12
13	#12	KITCHEN 108 COUNTER-HT. RECEPTACLES	20	1	1080			1440	1	20	KITCHEN 108 COUNTER-HT., & USB QUAD RECEPTACLES	#12	14
15	#12	KITCHEN 108 DEDICATED RECEPTACLE FOR DISHWASHER	20	1	1440			760	1	20	KITCHEN 108 DEDICATED RECEPTACLE FOR GARBAGE DISPOSAL	#12	16
17	#12	DINING ROOM 104 & BUNKROOM 113 USB QUAD WALL RECEPTACLES & AHU PLATFORM	20	1	1440			1260	1	20	BUNKROOM 113 USB QUAD & COUNTER RECEPTACLES	#12	18
19	#12	ICE MACHINE LOCATED IN UTILITY ROOM 118	20	1	1200			900	1	20	JUNCTION BOX (# 2-WAY SWITCH) FOR ROLLUP DOOR IN APPARATUS BAY 111	#12	20
21	#12	JUNCTION BOX (# 2-WAY SWITCH) FOR ROLLUP DOOR IN APPARATUS BAY 111	20	1	900			1080	1	20	RECEPTACLES FOR APPARATUS BAY 111, REST-ROOM 114, AHU, & MAINTENANCE BAY 121	#12	22
23	-	SPARE	20	1	-			900	1	20	JUNCTION BOX (# 2-WAY SWITCH) FOR ROLLUP DOOR IN MAINTENANCE BAY 121	#12	24
25	#12	JUNCTION BOX (# 2-WAY SWITCH) FOR ROLLUP DOOR IN MAINTENANCE BAY 121	20	1	900			180	1	20	DEDICATED WEATHER-PROOF RECEPTACLE FOR GENERATOR (BLOCK HEATER)	#12	26
27	#12	DEDICATED RECEPTACLE IN MECH/ELEC ROOM 123	20	1	180			1250	2	20	ELECTRIC SPACE HEATER LOCATED IN ATTIC	#12	28
29	#12	GENERATOR BATTERY CHARGER	20	1	340			1250	2	20	ELECTRIC SPACE HEATER LOCATED IN ATTIC	#12	30
31	#12	EXTERIOR WEATHER PROOF GFCI RECEPTACLES FOR LIGHTS	20	1	900			900	1	20	EXTERIOR WEATHER PROOF GFCI RECEPTACLES FOR LIGHTS AND HVAC UNITS	#12	32
33	#12	GAS HOT WATER HEATER IGNITOR(S)	20	1	1800			1080	1	20	RECEPTACLES FOR APPARATUS BAY 111	#12	34
35	-	SPARE	20	1	-			1080	1	20	RECEPTACLES FOR APPARATUS BAY 111, & MAINTENANCE BAY 121	#12	36
37	#12	KUSSMAIL AUTO-ELECT SYSTEM	20	1	1200			1200	1	20	KUSSMAIL AUTO-ELECT SYSTEM	#12	38
39	#12	ELECTRIC SPACE HEATER LOCATED IN ATTIC	20	2	1250			1250	2	20	ELECTRIC SPACE HEATER LOCATED IN ATTIC	#12	40
41					1250			1250	2	20	ELECTRIC SPACE HEATER LOCATED IN ATTIC	#12	42
					TOTAL CONNECTED LOAD (VA) = 95,680								
					AØ = 18,410		BØ = 17,270						

CLECO Power Company Electrical Load Summary

Project Name: FIRESTATION #10
 Project Address: LAKESHORE VISTA BLVD
 City / Town: SLIDELL, LOUISIANA

Intended Use: Firestation
 Requested Service: 120/240 Volts 1Ø Phase 3 Wires
 Service Entrance Size: 400 Amps
 HVAC Tonnage: 9 Tons
 Largest Motor: N/A HP
 Total Building Square Footage: 6,526 Square Feet
 Living Unit Square Footage: 2,624 Square Feet
 Storage Square Footage: 3,902 Square Feet

LOAD SOURCE	1Ø-kva	3Ø-kva
Building Lighting	14.0	-
Electric Water Heating	-	-
Heat Pumps	17.6	-
Supplemental Heat System	7.5	-
Air Conditioning Condensing Units	-	-
Electrical Heating (Primary) - AHUS	7.1	-
Cooking	9.6	-
Refrigeration	3.3	-
Receptacles (Standard)	20.7	-
Receptacles (Computer)	2.0	-
Total Motors (Exclude HVAC)	9.7	-
Exterior Lighting	0.7	-
Miscellaneous - Ceiling Fans	2.2	-
Other (OVERHEAD ROLL-UP DOORS)	3.6	-

GENERAL PANEL NOTES

- ELECTRICAL CONTRACTOR SHALL VISIT SITE AND FAMILIARIZE HIMSELF WITH EXISTING CONDITIONS, PRIOR TO SUBMISSION OF BID. ANY DISCREPANCIES BETWEEN PLANS AND ACTUAL CONDITIONS SHALL BE BROUGHT TO THE ATTENTION OF THE ARCHITECT AND BE INCLUDED IN FINAL BID.
- COORDINATE ELECTRICAL WORK WITH THE WORK OF OTHER TRADES.
- INSTALL "LOCK-DOGS" ON CIRCUIT BREAKERS FOR EMERGENCY LIGHTS AND EXIT LIGHTS TO PREVENT ACCIDENTAL TURNING OF LIGHTS.
- SEE ARCHITECTURAL SHEETS FOR LOCATION OF FIRE RATED CONSTRUCTION. PROVIDE FIRE RATED PENETRATIONS THROUGH FIRE RATED CONSTRUCTION. ALL PENETRATION SYSTEMS SHALL BE UL LISTED.
- WALL MOUNTED THERMOSTAT, TEMPERATURE SENSOR, ETC. ARE SHOWN ON THE MECHANICAL DRAWINGS. REFER TO THOSE DRAWINGS FOR LOCATIONS.
- PROVIDE UL LISTED FIRE STOPPING FOR THE INTERIOR OF ALL CABLE TRAYS, SLEEVES, AND CONDUITS PENETRATING FIRE RATED CONSTRUCTION AFTER WIRE HAS BEEN INSTALLED IN SUCH CONSTRUCTION.
- CONDUIT ROUTING: ALL CONDUITS SHALL BE ROUTED IN WALLS AND CEILING SPACE EXCEPT TO SERVE FLOOR BOXES.
- METER LOCATION: THE HEIGHT OF THE METER SHALL BE BETWEEN 48" AND 66" AFF.
- WORKING SPACE: PROVIDE A CLEAR WORKING SPACE IN FRONT OF THE PANEL NOT LESS THAN 30 INCHES WIDE AND 36 INCHES DEEP WITH A MINIMUM HEADROOM CLEARANCE OF 6'-6".

DAMMON
 ENGINEERING, INC.
 LOUISIANA & MISSISSIPPI

Chief Engineer: Brian Misch, PE
 554 Old Spanish Trail
 Slidell, LA 70598
 www.dammonengineering.com
 info@dammonengineering.com
 PH: 985.649.5832

#	DESCRIPTION	DATE



NEW FIRE STATION #10
 ST. TAMMANY FIRE PROTECTION DISTRICT No. 1

2148 LAKESHORE VISTA BLVD
 SLIDELL, LA 70561

JOB No: 2519 DATE: 12-05-2025
 DRAWN BY: CKD CHECKED BY: BAY

SHEET TITLE:
 ELECTRICAL CIRCUIT PANELS AND ONE-LINE DIAGRAMS

DRAWING NUMBER:
E103

SHEET No: 37 of 37