

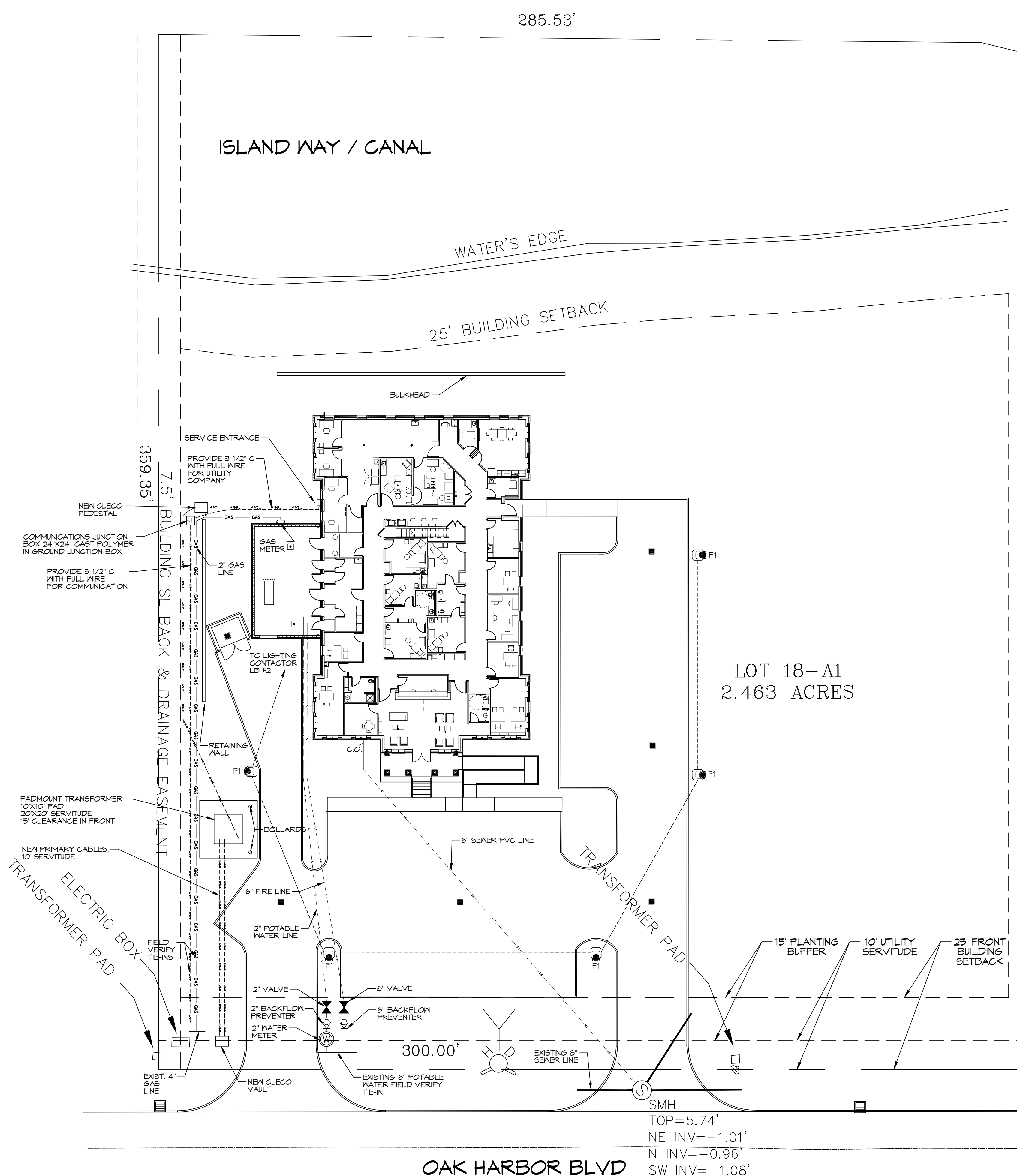



FILE NAME: J:\Projects\18-A1 - Diana Oak Harbor - Utility Site Plan.dwg  
 PLOT DATE: 05/16/2025 10:34:32 AM  
 PLOT SCALE: 1" = 20'-0"  
 PLOT SHEET: 1 OF 2



**SITE LIGHTING**

EXTERIOR LIGHTING SHALL BE SHADED OR INWARDLY DIRECTED IN SUCH A MANNER SO THAT NO DIRECT LIGHTING OR GLARE BE CAST BEYOND THE PROPERTY LINE. THE INTENSITY OF SUCH LIGHTING SHALL NOT EXCEED ONE FOOT CANDLE AS MEASURED AT THE ADJUTING PROPERTY LINE.

**GENERAL SITE NOTES**

1. PROVIDE ALL LABOR, MATERIAL AND EQUIPMENT FOR A COMPLETE OPERATING SYSTEM. CONTRACTOR IS TO FIELD VERIFY ALL EXISTING UTILITY LOCATIONS, ELEVATIONS, AND INVERTS PRIOR TO COMMENCING ANY WORK. CONTRACTOR SHALL PAY NECESSARY FEES FOR THE UTILITIES CONNECTIONS.
2. CONTRACTOR TO BE RESPONSIBLE TO VERIFY ANY INVERTS AND SET NEW INVERTS OF SEWAGE AND DRAINAGE PIPES.
3. ALL WORK AND MATERIAL TO COMPLY STRICTLY TO THE LATEST LOCAL CITY PARISH, STATE, AND NATIONAL GOVERNING CODES.
4. SEWAGE LINES 3" AND SMALLER SHALL BE SLOPED 1/4" PER FOOT AND LINES THAT ARE 4" AND LARGER SHALL BE SLOPED 1/8" PER FOOT.
5. CONTRACTOR SHALL CONTACT LOUISIANA ONE CALL PRIOR TO COMMENCEMENT OF SITE EXCAVATION.
6. CONTACT BENJAMIN LUCAS WITH THE MAGNOLIA WATER UTILITY DEPARTMENT AT (314) 406-1080 FOR TAPS. BLUCAS@CSWRGROUP.COM

**SITE UTILITIES LEGEND**

- v-v- NEW WATER LINE
- - - - NEW SEWER LINE
- - - - UNDERGROUND POWER
- - - - UNDERGROUND GAS

2-18 AWG, 12 AWG GND, IN 1" SCH 40 PVC, MINIMUM 30" BELOW GRADE.

PARKING LOT LUMINAIRE SEE LIGHTING SCHEDULE

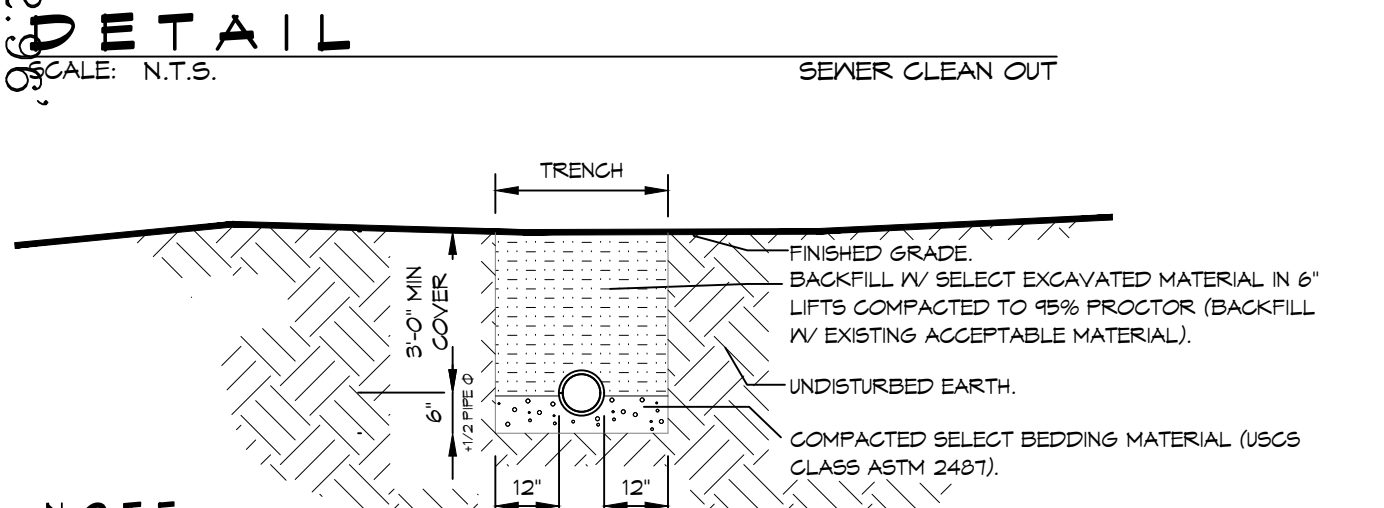
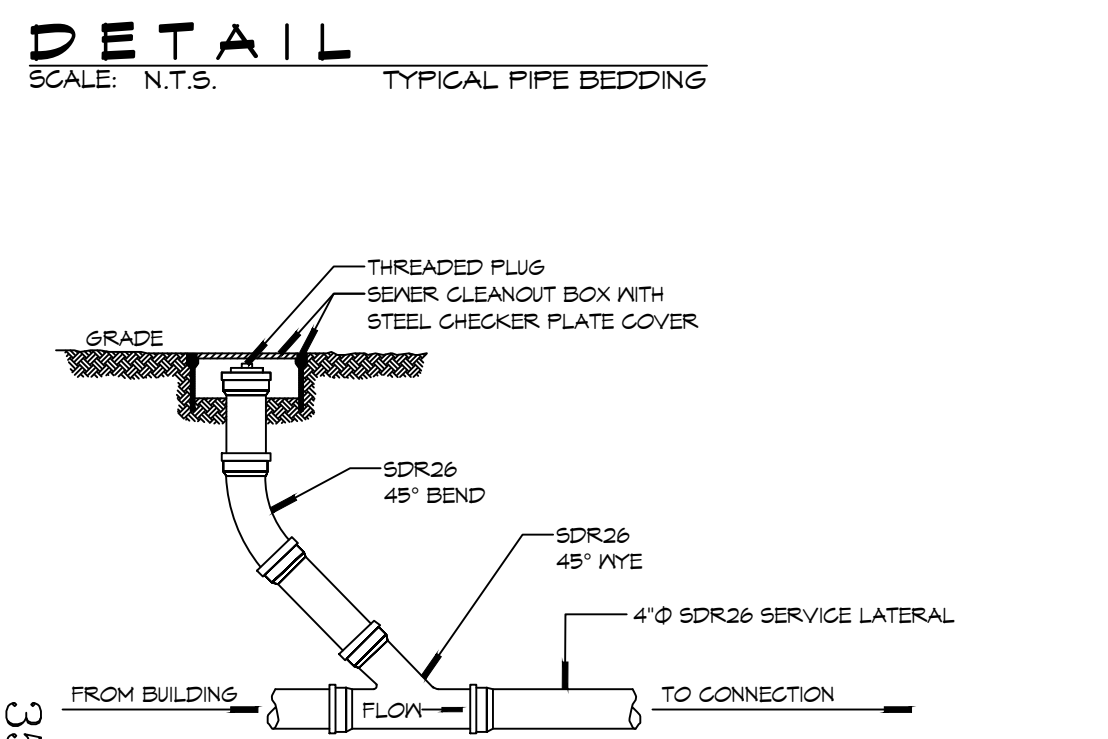
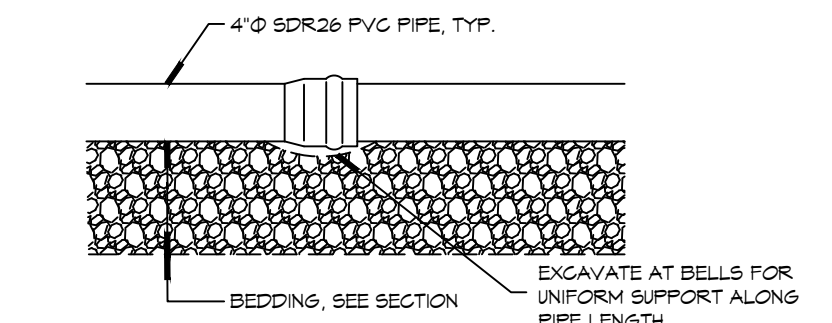

**NOTE:**  
 A MINIMUM SEPERATION OF 9" HORIZONTAL AND 18" VERTICAL IS REQUIRED BETWEEN WATER AND SEWER LINES. SEWER LINE SHALL BE A MINIMUM 18" BELOW THE WATER LINE.

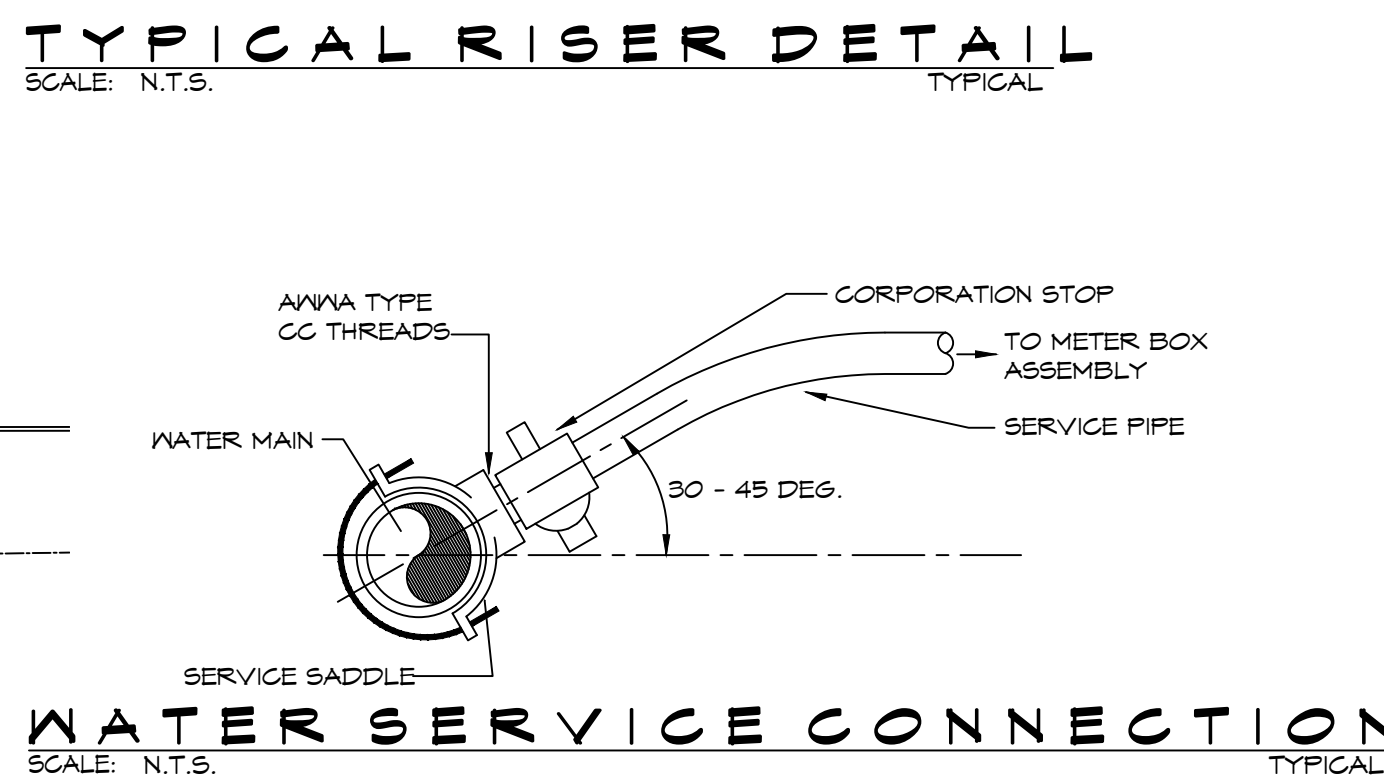
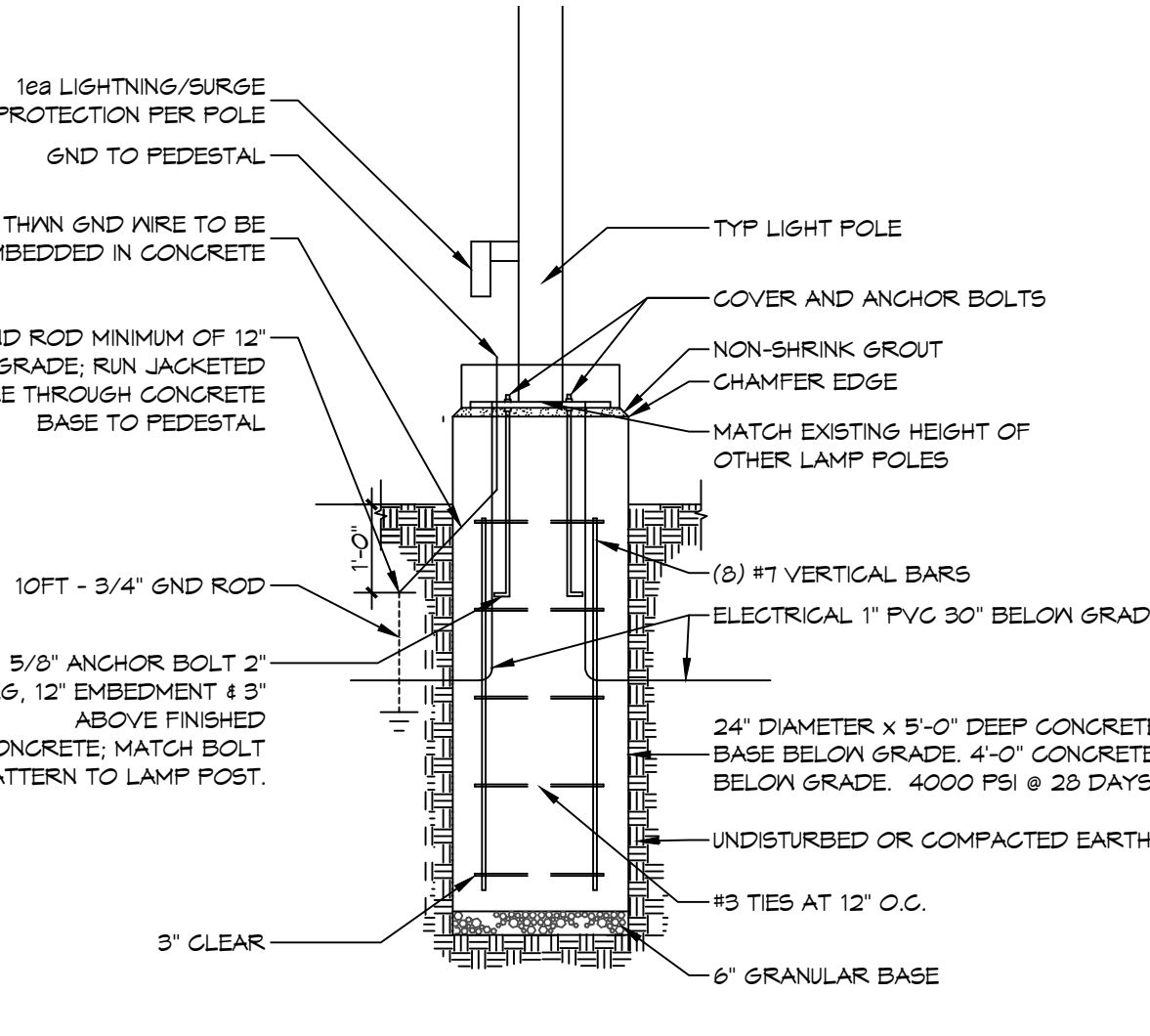
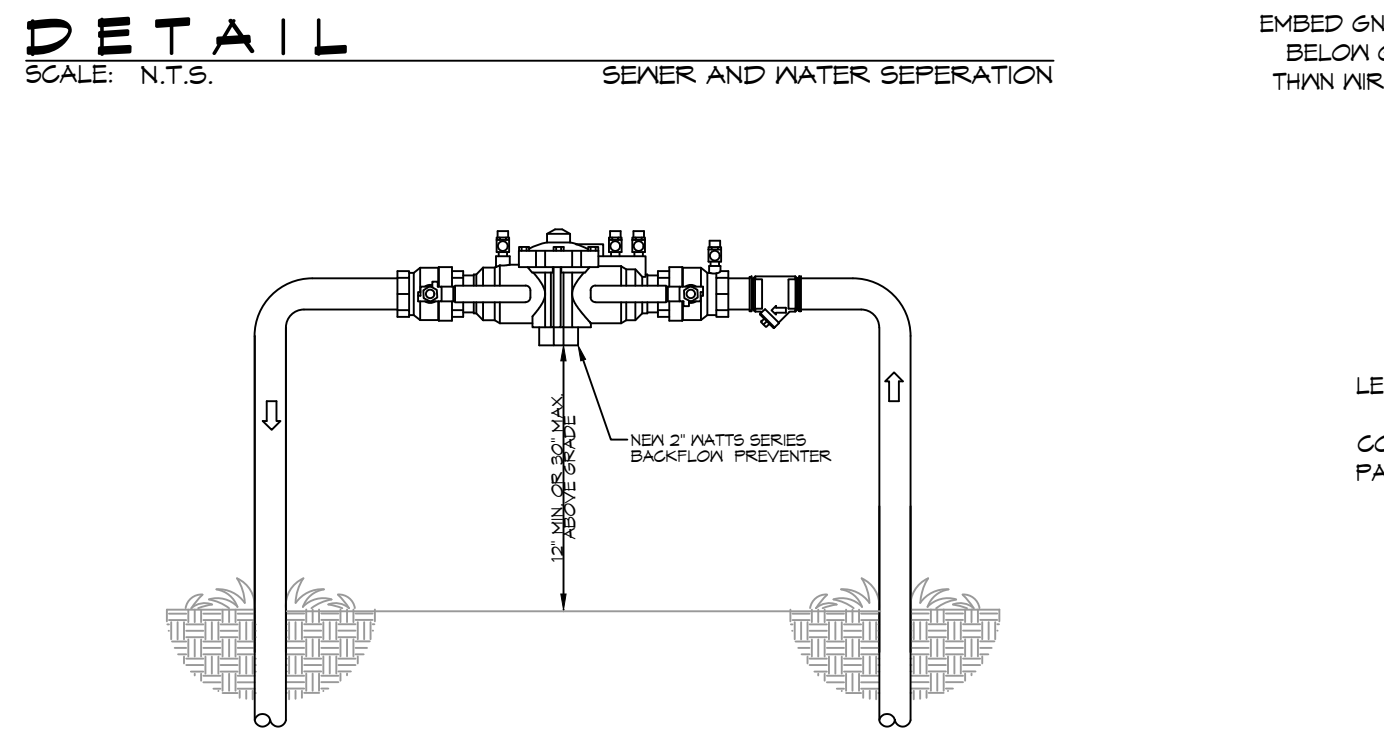

**DAMMON ENGINEERING, INC.**  
 LOUISIANA & MISSISSIPPI

Chief Engineer: Brian Mistich, PE  
 554 Old Spanish Trail  
 Slidell, LA 70468  
 www.dammonengineering.com  
 info@dammonengineering.com  
 PH: 985.649.9532

#	DESCRIPTION	DATE



NEW MEDICAL OFFICE  
 DIANA OAK HARBOR REAL ESTATE LLC  
 540 OAK HARBOR BLVD  
 SLIDELL, LA 70468

JOB No: 2519 | DATE: 05-16-2025  
 DRAWN BY: C&D | CHECKED BY: BAW

SHEET TITLE:  
 UTILITY SITE PLAN

DRAWING NUMBER:  
**C3**

SHEET No: 5 of 52

REVIEWED FOR  
 STATE FIRE MARSHAL  
 AS PER REVIEW LETTER  
 BY: WILLIAM D. JONES, ARCHITECT, CBO  
*William D. Jones*







