



Butler Manufacturing
a division of BlueScope Buildings North America Inc.

DRAWING INDEX	
DRAWING TITLE	PAGES
COVER SHEET	
CODES AND LOADS	
NOTES	
ANCHOR ROD PLAN	
PRIMARY STRUCTURAL	
SECONDARY STRUCTURAL	
COVERING	
SPECIAL DRAWINGS	
STANDARD ERECTION DETAILS	
PLANOGRAPH DETAILS	

DRAWING RELEASE HISTORY		
TYPE	DATE	DESCRIPTION

GENERAL NOTES

MATERIALS

3 PLATE WELDED SECTIONS
COLD FORMED LIGHT GAGE SHAPES
BRACE RODS
HOT ROLLED MILL SHAPES
HOT ROLLED ANGLES
HOLLOW STRUCTURAL SECTION (HSS)
CLADDING

ASTM DESIGNATION

A529, A572, A1011, A1018
A653, A1011
A572, A510
A36, A529, A572, A588, A992
A529, A572, A588, A992
A500
A653, A792

GRADE 55
GRADE 60
GRADE 50
GRADE 36 OR 50
GRADE 50
GRADE B
GRADE 50 OR GRADE 80

HIGH STRENGTH BOLT TIGHTENING REQUIREMENTS

IT IS THE RESPONSIBILITY OF THE ERECTOR TO ENSURE PROPER BOLT TIGHTNESS IN ACCORDANCE WITH APPLICABLE REGULATIONS. SEE RCSC SPECIFICATION FOR STRUCTURAL JOINTS USING HIGH STRENGTH BOLTS FOR MORE INFORMATION. SEE ERECTION GUIDE FOR BOLT TIGHTENING INSTRUCTIONS. THE FOLLOWING CRITERIA MAY BE USED TO DETERMINE THE BOLT TIGHTNESS (I.E. -SNUG TIGHT OR PRE-TENSION) UNLESS REQUIRED OTHERWISE BY LOCAL JURISDICTION OR CONTRACT.

ALL A490 BOLTS SHALL BE "PRE-TENSIONED". A325 BOLTS IN PRIMARY FRAMING AND BRACING CONNECTIONS MAY BE "SNUG-TIGHT" EXCEPT AS FOLLOWS:

PRE-TENSION A325 BOLTS IF BUILDING SUPPORTS A CRANE GREATER THAN 5 TON CAPACITY.

PRE-TENSION A325 BOLTS IF BUILDING SUPPORTS MACHINERY THAT CREATES VIBRATION, IMPACT, OR STRESS REVERSALS ON CONNECTIONS.

PRE-TENSION A325 BOLTS IF LOCATED IN HIGH SEISMIC AREAS. FOR IBC BASED CODES; HIGH SEISMIC IS DESIGN CATEGORY D, E OR F. SEE CODES AND LOADS SECTION BELOW FOR DETAILS.

PRE-TENSION ANY CONNECTION WITH DESIGNATION A325-SC. SLIP CRITICAL (SC) CONNECTIONS MUST BE FREE OF PAINT, OIL OR OTHER MATERIALS THAT REDUCE FRICTION AT CONTACT SURFACES. GALVANIZED OR LIGHTLY RUSTED SURFACES ARE ACCEPTABLE.

IN CANADA, ALL A325 AND A490 BOLTS SHALL BE "PRE-TENSIONED", EXCEPT FOR SECONDARY MEMBERS AND FLANGE BRACES.

SECONDARY MEMBERS AND FLANGE BRACE CONNECTIONS ARE ALWAYS "SNUG TIGHT", UNLESS INDICATED OTHERWISE IN ERECTION DRAWING DETAILS.

INSPECTION AND TESTING

SPECIAL INSPECTIONS AND TESTING REQUIRED BY AUTHORITY HAVING JURISDICTION (AHJ) DURING CONSTRUCTION AND/OR STEEL FABRICATION IS THE RESPONSIBILITY OF THE OWNER OR OWNERS AUTHORIZED AGENT. WHEN REQUIRED, THE OWNER SHALL EMPLOY A QUALITY ASSURANCE AGENCY (QAA) APPROVED BY THE AHJ. THE BUILDER IS RESPONSIBLE TO COORDINATE BETWEEN THE QAA FIRM AND BBNA FABRICATION FACILITIES. THE TYPE AND EXTENT OF SPECIAL INSPECTIONS AND NDT WELD TESTING MUST BE SPECIFICALLY STIPULATED IN CONTRACT DOCUMENTS OR BBNA WILL ASSUME SPECIAL INSPECTIONS AND/OR NDT TESTING ARE WAIVED AS PERMITTED BY THE BUILDING CODE BASED ON BBNA FACILITIES IAS AC472 ACCREDITATION.

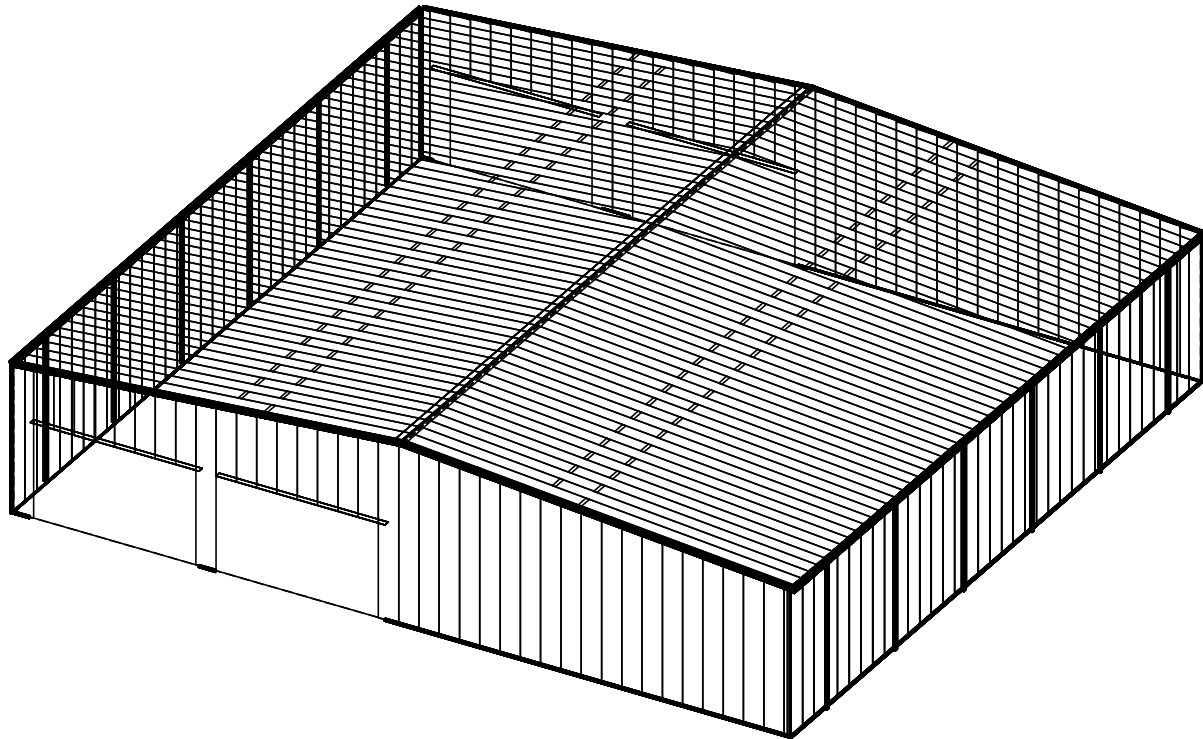

THE BUTLER MFG. ENGINEER'S SEAL APPLIES ONLY TO THE WORK PRODUCT OF BUTLER MFG. AND DESIGN AND PERFORMANCE REQUIREMENTS SPECIFIED BY BUTLER. THE BUTLER MFG. ENGINEER'S SEAL DOES NOT APPLY TO THE PERFORMANCE OR DESIGN OF ANY OTHER PRODUCT OR COMPONENT FURNISHED BY BUTLER EXCEPT TO ANY DESIGN OR PERFORMANCE REQUIREMENTS SPECIFIED BY BUTLER.

THIS DRAWING, INCLUDING THE INFORMATION HEREON, REMAINS THE PROPERTY OF BUTLER MFG. IT IS PROVIDED SOLELY FOR ERECTING THE BUILDING DESCRIBED IN THE APPLICABLE PURCHASE ORDER AND MAY BE REPRODUCED ONLY FOR THAT PURPOSE. IT SHALL NOT BE MODIFIED, REPRODUCED OR USED FOR ANY OTHER PURPOSE WITHOUT PRIOR WRITTEN APPROVAL OF BUTLER MFG.

THE GENERAL CONTRACTOR AND/OR ERECTOR IS SOLELY RESPONSIBLE FOR ACCURATE GOOD QUALITY WORKMANSHIP IN ERECTING THIS BUILDING IN ACCORDANCE WITH THIS DRAWING, DETAILS REFERENCED IN THIS DRAWING, ALL APPLICABLE BUTLER MFG. ERECTION GUIDES, AND INDUSTRY STANDARDS PERTAINING TO PROPER ERECTION, INCLUDING THE CORRECT USE OF TEMPORARY BRACING.

B

BUTLER MANUFACTURING
1540 GENESSEE ST. KANSAS CITY, MO 64102

COVER SHEET

BUILDER: Salacia Construction
CUSTOMER:
LOCATION: Slidell, Louisiana
PROJECT: RV Storage - Legacy Buick GMC - Slidell
BUILDER'S PO#:



JOB #:
DATE: 4/5/2024
DRAWN/CHECK: /
PAGE:

Butler Manufacturing
VPC VERSION: ADVNXT 6.8

Codes and Loads
 WHEN MULTIPLE BUILDINGS ARE INVOLVED, SPECIFIC LOAD FACTORS FOR DIFFERING OCCUPANCIES, BUILDING DIMENSIONS, HEIGHTS, FRAMING SYSTEMS, ROOF SLOPES, ETC., MAY RESULT IN DIFFERENT LOAD APPLICATION FACTORS THAN INDICATED BELOW. SEE CALCULATIONS FOR FURTHER DETAILS. WIND LOADS ARE APPLIED TO OVERALL BUILDING ENVELOPE. COMMON WALLS BETWEEN CONNECTED SHAPES ARE NOT SUBJECT TO EXTERNAL WIND LOADS.

City: Slidell County: St Tammany State: Louisiana Country: United States

Building Code
 Building Code: 2021 International Building Code Structural: 16AISC - ASD Rainfall: I: 1.00 inches per hour
 Building Risk/Occupancy Category: II (Standard Occupancy Structure) Cold Form: 16AISI - ASD f'c: 3000.00 psi Concrete

Dead and Collateral Loads Material Dead Weight Roof Live Load
 Collateral Gravity: 5.00 psf Roof Covering + Second. Dead Load: 2.26 psf Roof Live Load: 20.00 psf Not Reducible
 Collateral Uplift: 0.00 psf Frame Weight (assumed for seismic): 2.50 psf

Wind Load Snow Load Seismic Load
 Wind Speed: Vult: 143.00 (Vasd: 110.77) mph Ground Snow Load: pg: 5.00 psf Lateral Force Resisting Systems using Equivalent Force Procedure
 The 'Envelope Procedure' is Used Flat Roof Snow: pf: 4.20 psf Mapped MCE Acceleration: Ss: 8.90 %g
 Primaries Wind Exposure: B - Kz: 0.701 Design Snow (Sloped): ps: 4.20 psf Mapped MCE Acceleration: S1: 5.60 %g
 Parts Wind Exposure Factor: 0.640 Rain Surcharge: 0.00 psf Site Class: Stiff soil (D) - Determined
 Wind Enclosure: Enclosed Specified Minimum Roof Snow: 5.00 psf (Code) Seismic Importance: Ie: 1.000
 Topographic Factor: Kzt: 1.0000 Exposure Factor: 2 Partially Exposed - Ce: 1.00 Design Acceleration Parameter: Sds: 0.0949
 Ground Elevation Factor: Ke: 0.9997 Snow Importance: Is: 1.000 Design Acceleration Parameter: Sd1: 0.0896
 Hurricane Prone Region Thermal Factor: Unheated - Ct: 1.20 Seismic Design Category: B
 Windborne Debris Region Ground / Roof Conversion: 0.70 Seismic Snow Load: 0.00 psf
 NOT Impact Resistant Covering Unobstructed, Slippery % Snow Used in Seismic: 0.00
 Base Elevation: 0/0/0 Diaphragm Condition: Flexible
 Site Elevation: 7.0 ft Fundamental Period Height Used: 24/3/4

Transverse Direction Parameters
 System NOT detailed for Seismic
 Redundancy Factor: Rho: 1.00
 Fundamental Period: Ta: 0.3591
 R-Factor: 3.00
 Overstrength Factor: Omega: 2.50
 Deflection Amplification Factor: Cd: 3.00
 Base Shear: V: 0.0316 x W

Longitudinal Direction Parameters
 System NOT detailed for Seismic
 Redundancy Factor: Rho: 1.00
 Fundamental Period: Ta: 0.2187
 R-Factor: 3.00
 Overstrength Factor: Omega: 2.50
 Deflection Amplification Factor: Cd: 3.00
 Base Shear: V: 0.0316 x W

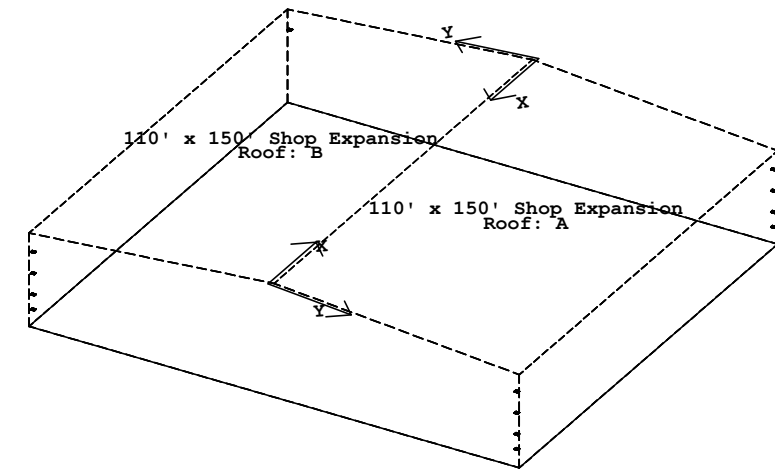

Shape	Surface	Description	X Location	Y Location	Magnitude
110' x 150' Shop Expansion	Roof: A	Unbalanced Snow Load 1, Shifted Left : Roof: A	0.0 ft	16.3 ft	7.5 psf
			0.0 ft	0.0 ft	7.5 psf
			105.0 ft	0.0 ft	7.5 psf
			105.0 ft	16.3 ft	7.5 psf
110' x 150' Shop Expansion	Roof: B	Unbalanced Snow Load 1, Shifted Right : Roof: B	0.0 ft	16.3 ft	7.5 psf
			0.0 ft	0.0 ft	7.5 psf
			105.0 ft	0.0 ft	7.5 psf
			105.0 ft	16.3 ft	7.5 psf

- The Snow Buildup loading shown is in addition to the flat or sloped roof snow.
- The X and Y Location dimensions are from the point of origin of each surface.

THE BUTLER MFG. ENGINEER'S SEAL APPLIES ONLY TO THE WORK PRODUCT OF BUTLER MFG. AND DESIGN AND PERFORMANCE REQUIREMENTS SPECIFIED BY BUTLER. THE BUTLER MFG. ENGINEER'S SEAL DOES NOT APPLY TO THE PERFORMANCE OR DESIGN OF ANY OTHER PRODUCT OR COMPONENT FURNISHED BY BUTLER EXCEPT TO ANY DESIGN OR PERFORMANCE REQUIREMENTS SPECIFIED BY BUTLER.	THIS DRAWING, INCLUDING THE INFORMATION HEREON, REMAINS THE PROPERTY OF BUTLER MFG. IT IS PROVIDED SOLELY FOR ERRECTING THE BUILDING DESCRIBED IN THE APPLICABLE PURCHASE ORDER AND MAY BE REPRODUCED ONLY FOR THAT PURPOSE. IT SHALL NOT BE MODIFIED, REPRODUCED OR USED FOR ANY OTHER PURPOSE WITHOUT PRIOR WRITTEN APPROVAL OF BUTLER MFG.	B BUTLER MANUFACTURING 1540 GENESSEE ST. KANSAS CITY, MO 64102	CODES AND LOADS		
			REV: _____ DATE: _____ BY: _____ DESCRIPTION: _____	BUILDER: Salacia Construction CUSTOMER: _____ LOCATION: Slidell, Louisiana PROJECT: RV Storage - Legacy Buick GMC - Slidell BUILDER'S PO#: _____	
THE GENERAL CONTRACTOR AND/OR ERECTOR IS SOLELY RESPONSIBLE FOR ACCURATE GOOD QUALITY WORKMANSHIP IN ERRECTING THIS BUILDING IN ACCORDANCE WITH THIS DRAWING, DETAILS REFERENCED IN THIS DRAWING, ALL APPLICABLE BUTLER MFG. ERECTION GUIDES, AND INDUSTRY STANDARDS PERTAINING TO PROPER ERECTION, INCLUDING THE CORRECT USE OF TEMPORARY BRACING.		DRAWING SCALE: NTS	BUTLER MANUFACTURING VPC VERSION: ADVNXT 6.8		

BUILDER/CONTRACTOR RESPONSIBILITIES

Butler Mfg. follows the guidelines as outlined in the AISC and MBMA Codes of Standard Practice. Butler Mfg. standard product specifications, design, fabrication, quality criteria shall govern all work unless stipulated otherwise in the contract documents. In case of discrepancies between Butler Mfg. structural plans and plans for other trades, Butler Mfg. structural plans shall govern.

It is the responsibility of the Builder to obtain approvals and permits from all governing agencies and jurisdictions as required. Approval of Butler Mfg drawings constitutes the builders acceptance of Butler interpretation of the contract purchase order. Unless specific design criteria concerning interface design and details are furnished as part of the contract, Butler Mfg. design assumptions shall govern.

Butler engineers are not Project Engineers or Engineer of Record for the overall project. Butler engineering supply sealed engineering design data and drawings for Butler supplied material as part of the overall project for use by others to obtain permits, approvals, and coordinate with other trades. All interface and/or compatibility of any materials not furnished by Butler are to be considered and coordinated by the builder or A/E firm.

CONSTRUCTION & ERECTION RESPONSIBILITY

The Builder is responsible for construction in strict accordance with Butler Mfg. "FOR CONSTRUCTION" drawings and all applicable product installation guides. Butler is not responsible for work done from any other Butler drawings that are not marked "FOR CONSTRUCTION", nor any drawings prepared by others.

As erected field assemblies of members shall be as specified in MBMA Code of Standard Practice (in Canada – CSA S16), which require L/500 tolerance of installed members. Occasional field work including shimming, cutting, coping, and drilling for final fit-up are considered part of erection. Specified field work and field welding conditions indicated on these drawings shall also be included in the erectors scope of work. See Erection Guide for shimming procedure. For building with top riding bridge cranes see Crane Data drawing for column plumb tolerance.

The building erector shall be properly licensed and experienced in erecting metal building systems. The Builder is responsible for having knowledge of, and shall comply with, all OSHA requirements and all other governing site safety criteria. The builder is responsible for designing, supplying, locating and installing temporary supports and bracing during erection of the building. Butler bracing is designed for code required loads after building completion and shall not be considered as adequate erection bracing. See Erection Guide.

Shimming of steel buildings during erection may be required to accomodate allowable tolerances during fabrication and erection. Special care should be taken by the building erector to shim connections where key dimensions must be maintained for building performance as even small tolerances can have a significant impact on critical dimensions such as height, clearances and plumbness, especially as the size of the member or building increases. Conditions where shimming should be expected can include but are not limited to large door openings, critical clear height requirements, cranes, buildings greater than 45 feet in height, clear spans greater than 125 feet and adjacent frames with different characteristics (like clear span frames adjacent to an endwall or modular frame). Shims are normally provided by the erector, but may be ordered upon request by contacting your Project Manager.

EXISTING STRUCTURES

Butler must be advised of any structure that is within 20 ft. of Butler's building. Load effects from snow drifting, wind effects, and seismic separation must be considered for both the new and existing structures. Butler has designed the new Butler building for these effects. The owner/builder are responsible for employing a Professional Engineer to review and verify the existing structure for all load effects from the adjacent Butler building.

BRACING

Tension brace rods work in pairs to balance forces caused by initial tensioning. Care must be taken while tightening brace rods so as not to cause accidental or misalignment of components. All rods must be installed loose and then tightened. Rods should not exhibit excessive sag. For long or heavy rods, or angles it may be necessary to support the rods at mid-bay by suspending them from secondary members.

Bracing for seismic or wind loading of objects or equipment that are not a part of the Butler structure must be designed by a qualified professional to deliver lateral loads to primary frames and rod bracing struts. Equipment bracing and suspension connections must not impose torsion or minor axis loads, or cause local distortion in any Butler components. Butler accepts no responsibility for design or installation of bracing systems not furnished by Butler.

FIELD WELDING

All field welding shall be done at the direction of a design professional, and done in accordance with governing requirements (AWS in USA, CWB in Canada) by welders qualified to perform the welding as directed by the applicable welding procedure specification (WPS). A WPS shall be prepared by the contractor for each welding variation specified. The contractor is responsible for any special welding inspection as required by local jurisdiction. Filler metal shall be 70 ksi (480 MPa) tensile strength. For welds in high seismic force regions, the minimum Charpy V-Notch toughness shall meet (or exceed) the design and performance requirements specified by Butler. The interpass temperatures shall not exceed 500°F (260°C).

SIGNAGE

The Builder is responsible for furnishing signs as required by Code and the Building Department, including but not limited to, exits, occupancy limits, floor loading limits, and bulk storage limits. Floor loading signs shall clearly indicate maximum floor live load permitted. Bulk storage facilities shall have signs clearly posted on all loaded walls indicating the type of commodity stored and the maximum storage height. Signs shall be clearly visible when building is fully loaded to design level. Overloading of floors or walls may result in failure.

DELIVERIES

It is the responsibility of the builder to have adequate equipment available at the job site to unload trucks in a safe and timely manner. The Builder will be responsible for all retention charges from carriers as a result of job site unloading delays.

Claims for damage or shorts MUST be noted on the Bill-of-Lading or delivery receipt and filed against the carrier by the consignee as per Butler's Terms of Sales (F.O.B. Plant) under the Uniform Commercial Code. It is critical that damages or shorts be noted on the Bill-of-Lading or you have little recourse with the carrier. Immediately upon delivery of material, material quantities are verified by the Builder against quantities billed on the shipping document. Neither the Manufacturer nor the carrier is responsible for material shortages against quantities billed on the shipping document if such shortages are not noted on the shipping documents upon delivery of material and acknowledged by the carriers agent. For materials concealed in bundles, boxes, or crates, shortages must be reported immediately upon unpacking. Should products get wet, bundled and crated materials must be unpacked and unbundled immediately to provide drainage of trapped moisture. See Erection Guide for proper job site storage procedure.

SEALANTS

Sealants shall be applied in strict accordance with Butler details or weather tightness will be compromised. Sealant must be applied in temperatures and weather conditions consistent with labeling.

INDEPENDENT MEZZANINES

Independent mezzanines must be designed by a professional engineer. The engineer must ensure that proper isolation from the Butler building has been provided to avoid structural damage due to differential movements, or inadvertently apply loads to the Butler structure. Butler accepts no responsibility for the design of the independent mezzanine.

FIRE CODE COMPLIANCE

It is the responsibility of the project design professional and builder to comply with local fire code regulations including consideration of, but not limited to, building use and occupancy, all building construction materials, separation requirements, egress requirements, fire protection systems, etc. Builder shall advise Butler of any special requirements to be furnished by Butler.

FIELD MODIFICATIONS

Modifications to this building from details and instructions contained on these drawings must be approved in writing by Butler Mfg. engineers, or other licensed structural engineer. This includes, but is not limited to, removal of roof or wall cladding, removing or moving any flange braces or rod braces, cutting of openings for doors, windows or RTU's, correction of fabrication errors, etc. The owner shall not impose loads to this structure beyond what is specified for this building in the contract documents. Butler Mfg. accepts no responsibility for the consequences of any unauthorized additions, alterations, or added loads to this structure.

If the builder intends to invoice Butler Mfg. for modifications in excess of \$1000, The builder must notify Butler Mfg. immediately, and obtain a Work Authorization from Butler Mfg prior to proceeding. All final claims must be submitted to Butler Mfg with all supporting documentation within 30 days of the building completion. Claims submitted without work authorizations, or after 30 days will not be accepted. Correction of minor misfits, shimming and plumbing, moderate amount of reaming, drilling, chipping / cutting and minor welding are considered by Code of Standard Practice to be part of erection are not subject to claim reimbursement.

CONCRETE/MASONRY/CONVENTIONAL STUD WALLS

The engineer responsible for the design of the wall system is responsible for coordinating with, or specifying to Butler Mfg, any wall to steel compatibility issues such as drift and deflection compatibility, special base details, and wall to Butler steel connections. All fasteners, sealant and counter flashing of wall systems are to be provided by contractor. The engineer responsible for the wall shall design the anchorage to Butler supporting elements consistent with Code required forces.

PANELS

Oil canning is an inherent characteristic of cold formed steel panels. It is the result of several factors that include induced stresses in the raw material delivered to Butler, fabrication methods, installation procedures, and post installation thermal forces. Thru fastened panels will exhibit some dimpling when installed, especially when insulation is installed between panels and secondary supports. Dimpling can be minimized by careful installation, taking care not to over drive fasteners.

Roof rumble is a phenomenon that is caused by wind gusts lifting up on the roof panels and then springing back into place. All panels experience this action to some degree, especially with concealed clip Standing Seam panels. Roof rumble noise may be minimized by providing a layer of blanket insulation between the panels and any hard support surface such as steel secondary members, substrates such as plywood, steel decking, or rigid board insulation. A minimum of 3 inch thick blanket is recommended over steel secondary members, or 2 inch over substrates.

Oil canning, dimpling, and roof rumble do not affect the structural integrity or weather tightness of the panels and is not grounds for rejection of panels.

The Standing Seam joint detail is designed with an interlocking feature for ease of installation. However, it is imperative that installed Standing Seam panels be secured to the secondary structural members and properly seamed prior to departure from the job site each day.

SKYLIGHTS

Local building departments may require added fall restraint due to conditions that may affect the skylight structural integrity. It is the responsibility of the builder to determine and provide any added fall restraint under the skylight as may be required by your building department.

RAIN WATER RUNOFF

Drainage systems must be designed by the project professional to comply with code requirements. Butler is not responsible for drainage designs, overflow scuppers, down piping, etc. The project professional and contractor are responsible to ensure that primary drains and overflow devices such as scuppers and auxiliary drains are provided as required for the required rain intensity at the building perimeter and at valley conditions to prevent ponding.

STEEL SHOP COAT

The purpose of Butler's shop coat is to provide protection for the steel members during transportation, during temporary job site storage and during erection. Standard shop formulation is not designed to perform as a finish coat when exposed to environmental conditions. Members shall be kept free of the ground and properly drained during job site storage. It is the Builder's responsibility to ensure that if a finish coat is being applied over Butler shop coat that the painting contractor verifies compatibility between his finish coat and Butler's shop coat.

BUTLER MFG. ACCREDITATIONS AND APPROVALS

Fabricator Approvals

IAS AC472 Approvals: (www.iasonline.org/services/metal-building-inspection)
Listed under BlueScope Buildings North America, Inc.
City of Los Angeles, CA #FB00031; City of Houston, TX 767;
City of Phoenix, AZ C19-02008; Clark County, NV 43 & 833, San Bernardino County, CA 289, State of Utah, City of Richmond, Ca.

Design Approvals

IAS AC472 Approvals: (www.iasonline.org/services/metal-building-inspection)
Listed under Butler Manufacturing, a Division of BlueScope Buildings North America, Inc.

Canadian CSA A660 Certifications

(www.cwbgroup.org)
Listed under BlueScope Buildings North America, Inc.

Engineering Certifications of Authorization

USA--AL#CA-5589-E; AZ#22225-0; AR#576; FL#30427; GA#PEF007551; ID#C-2470; IL#184-002649; KS#E-29; KY#4490; LA#EF6722; MS#E-0592; MO#E-2010007736; NC#F-0998; ND#1579PE; NJ#24GA28318800; NV#20437; OH#05898; OK#CA4170PE; RI#8838; SC#6206; SD#C-1787; TX#F4828; VA#0411001520; VA#0411001518; WA#4119; WV#C03059-00
CAN--AB#P08900; NB#F0951; NL#D0044; NS#30123; NT#P062; ON#100148796; and YT#PP134

THE BUTLER MFG. ENGINEER'S SEAL APPLIES TO THE DESIGN AND PERFORMANCE OF THE BUILDING SYSTEMS SHOWN ON THESE DRAWINGS. THE BUTLER MFG. ENGINEER'S SEAL DOES NOT APPLY TO THE PERFORMANCE OR DESIGN OF ANY OTHER PRODUCT OR COMPONENT FURNISHED BY BUTLER EXCEPT TO ANY DESIGN OR PERFORMANCE REQUIREMENTS SPECIFIED BY BUTLER.

THIS DRAWING, INCLUDING THE INFORMATION HEREON, REMAINS THE PROPERTY OF BUTLER MFG. IT IS PROVIDED SOLELY FOR ERECTING THE BUILDING DESCRIBED IN THE APPLICABLE PURCHASE ORDER AND MAY BE REPRODUCED ONLY FOR THAT PURPOSE. IT SHALL NOT BE MODIFIED, REPRODUCED OR USED FOR ANY OTHER PURPOSE WITHOUT PRIOR WRITTEN APPROVAL OF BUTLER MFG.
THE GENERAL CONTRACTOR AND/OR ERECTOR IS SOLELY RESPONSIBLE FOR ACCURATE GOOD QUALITY WORKMANSHIP IN ERECTING THIS BUILDING IN ACCORDANCE WITH THIS DRAWING, DETAILS REFERENCED IN THIS DRAWING, ALL APPLICABLE BUTLER MFG. ERECTION GUIDES, AND INDUSTRY STANDARDS PERTAINING TO PROPER ERECTION, INCLUDING THE CORRECT USE OF TEMPORARY BRACING.

B	BUTLER MANUFACTURING			ERECTION NOTES	
	1540 GENESSEE ST. KANSAS CITY, MO 64102				
	REV.	DATE	BY		DESCRIPTION
DRAWING SCALE: NTS				BUILDER: Salacia Construction CUSTOMER: LOCATION: Slidell, Louisiana PROJECT: RV Storage - Legacy Buick GMC - Slidell BUILDER'S POF:	



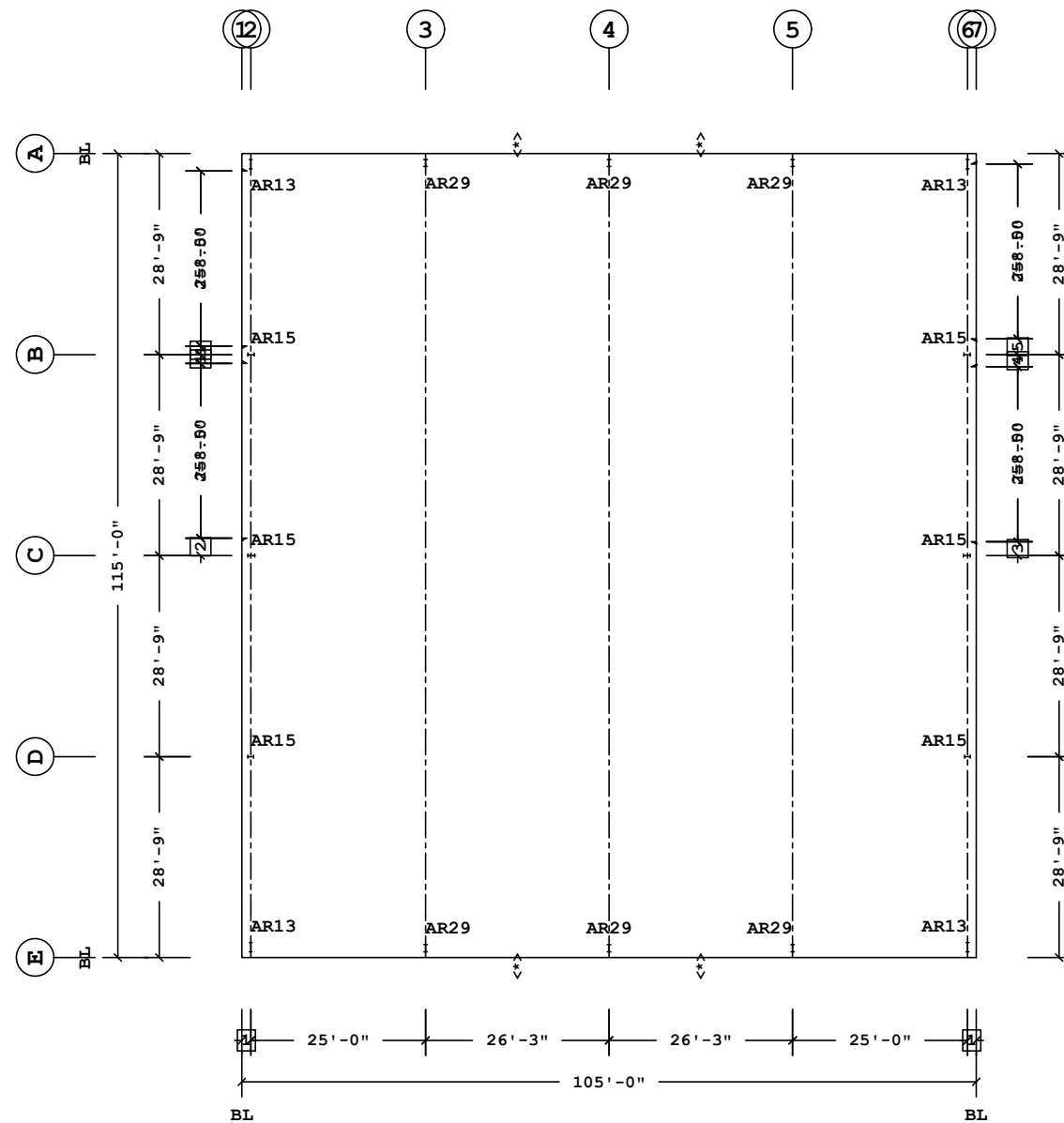

ANCHOR ROD PLAN

- 5 2'-3"
- 4 1'-9"
- 3 2'-0"
- 2 2'-6"
- 1 1'-3"

Dimension Key

Finished Floor Elevation = 100'-0" (Unless Noted Otherwise)

<-> THE BUILDING IS DESIGNED WITH BRACING DIAGONALS IN THE DESIGNATED BAYS. COLUMN BASE REACTIONS, BASE PLATES AND ANCHOR RODS ARE AFFECTED BY THIS BRACING AND DIAGONALS MAY NOT BE RELOCATED WITHOUT CONSULTING THE BUILDING SUPPLIERS ENGINEER.

THE BUTLER MFG. ENGINEER'S SEAL APPLIES ONLY TO THE WORK PRODUCT OF BUTLER MFG. AND DESIGN AND PERFORMANCE REQUIREMENTS SPECIFIED BY BUTLER. THE BUTLER MFG. ENGINEER'S SEAL DOES NOT APPLY TO THE PERFORMANCE OR DESIGN OF ANY OTHER PRODUCT OR COMPONENT FURNISHED BY BUTLER EXCEPT TO ANY DESIGN OR PERFORMANCE REQUIREMENTS SPECIFIED BY BUTLER.

THIS DRAWING, INCLUDING THE INFORMATION HEREON, REMAINS THE PROPERTY OF BUTLER MFG. IT IS PROVIDED SOLELY FOR ERECTING THE BUILDING DESCRIBED IN THE APPLICABLE PURCHASE ORDER AND MAY BE REPRODUCED ONLY FOR THAT PURPOSE. IT SHALL NOT BE MODIFIED, REPRODUCED OR USED FOR ANY OTHER PURPOSE WITHOUT PRIOR WRITTEN APPROVAL OF BUTLER MFG.

THE GENERAL CONTRACTOR AND/OR ERECTOR IS SOLELY RESPONSIBLE FOR ACCURATE GOOD QUALITY WORKMANSHIP IN ERECTING THIS BUILDING IN ACCORDANCE WITH THIS DRAWING, DETAILS REFERENCED IN THIS DRAWING, ALL APPLICABLE BUTLER MFG. ERECTION GUIDES, AND INDUSTRY STANDARDS PERTAINING TO PROPER ERECTION, INCLUDING THE CORRECT USE OF TEMPORARY BRACING.

B	BUTLER MANUFACTURING 1540 GENESSEE ST. KANSAS CITY, MO 64102			ANCHOR ROD PLAN	
	REV.	DATE	BY:	DESCRIPTION:	BUILDER: Salacia Construction
					CUSTOMER:
					LOCATION: Slidell, Louisiana
					PROJECT: RV Storage - Legacy Buick GMC - Slidell
					BUILDER'S PO#:
DRAWING SCALE: NTS				 Butler Manufacturing VPC VERSION: ADVNXT 6.8	
				JOB #:	
				DATE:	4/5/2024
				DRAWN/CHECK:	/
				PAGE:	

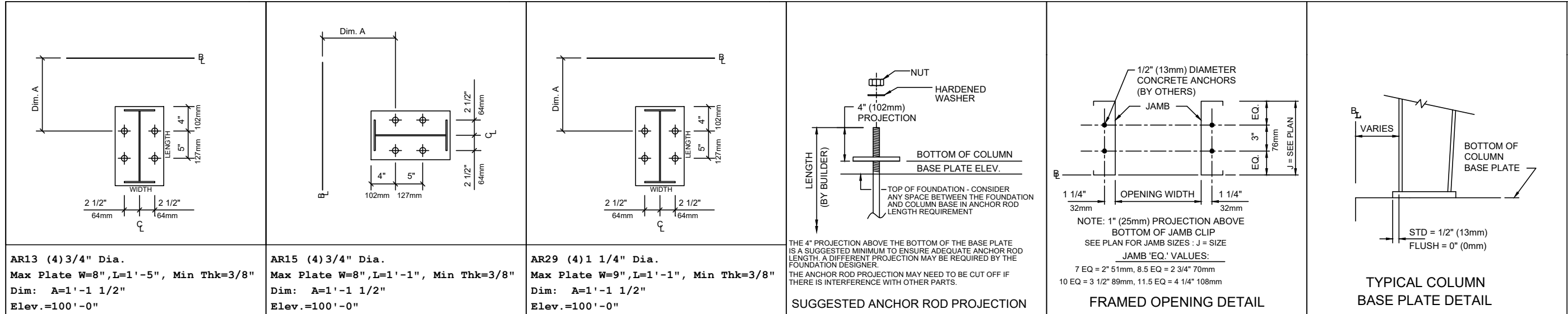

- ANCHOR RODS, NUTS, HARDENED WASHERS AND ANY OTHER EMBEDDED ITEMS ARE TO BE FURNISHED BY CONTRACTOR.
- ANCHOR ROD DIAMETERS WERE DETERMINED BY ALLOWABLE SHEAR AND TENSION PER AISC SPECIFICATIONS (FY=36KSI). (ASTM F1554 GRADE 36) ANCHOR ROD LENGTH, EFFECTS OF EMBEDDED ANCHOR ROD EDGE DIMENSIONS AND METHOD OF TRANSFERRING FORCES FROM ANCHOR RODS TO FOOTINGS ARE TO BE DETERMINED BY OTHERS.
- UNLESS OTHERWISE SPECIFIED, ANCHOR RODS ARE DESIGNED AND DETAILED AS "CAST-IN-PLACE" ANCHOR RODS WITH "SNUG TIGHT" CONNECTIONS.
- FOUNDATION MUST BE LEVEL, SQUARE AND SMOOTH. ANCHOR RODS MUST BE ACCURATELY PLACED AS SHOWN ON THIS DRAWING OR STEEL WILL NOT FIT. THE BUILDER IS RESPONSIBLE FOR ACCURATE SETTING OF ANCHOR RODS PER AISC CODE OF STANDARD PRACTICE, SEC 7.5 VARIATIONS ARE SUMMARIZED BELOW:
 - CENTERS OF ANY TWO AR'S WITHIN A COLUMN BASE GROUP: +-1/8"
 - CENTERS OF ADJACENT AR GROUPS: +-1/4"
 - TOPS OF AR'S: +-1/2"
 - ACCUMULATED DIM BETWEEN CENTERS OF AR GROUPS ALONG COLUMN LINE: +-1/4" PER 100FT., NOT TO EXCEED 1" TOTAL
 - DIM FROM CENTER OF ANY AR GROUP FROM COLUMN LINE: +-1/4"
- DESIGN LOADS AND REACTIONS ARE FURNISHED IN THE REACTIONS REPORT.

THE BUTLER MFG. ENGINEER'S SEAL APPLIES ONLY TO THE WORK PRODUCT OF BUTLER MFG. AND DESIGN AND PERFORMANCE REQUIREMENTS SPECIFIED BY BUTLER. THE BUTLER MFG. ENGINEER'S SEAL DOES NOT APPLY TO THE PERFORMANCE OR DESIGN OF ANY OTHER PRODUCT OR COMPONENT FURNISHED BY BUTLER EXCEPT TO ANY DESIGN OR PERFORMANCE REQUIREMENTS SPECIFIED BY BUTLER.

THIS DRAWING, INCLUDING THE INFORMATION HEREON, REMAINS THE PROPERTY OF BUTLER MFG. IT IS PROVIDED SOLELY FOR ERECTING THE BUILDING DESCRIBED IN THE APPLICABLE PURCHASE ORDER AND MAY BE REPRODUCED ONLY FOR THAT PURPOSE. IT SHALL NOT BE MODIFIED, REPRODUCED OR USED FOR ANY OTHER PURPOSE WITHOUT PRIOR WRITTEN APPROVAL OF BUTLER MFG.

THE GENERAL CONTRACTOR AND/OR ERECTOR IS SOLELY RESPONSIBLE FOR ACCURATE GOOD QUALITY WORKMANSHIP IN ERECTING THIS BUILDING IN ACCORDANCE WITH THIS DRAWING, DETAILS REFERENCED IN THIS DRAWING, ALL APPLICABLE BUTLER MFG. ERECTION GUIDES, AND INDUSTRY STANDARDS PERTAINING TO PROPER ERECTION, INCLUDING THE CORRECT USE OF TEMPORARY BRACING.

B	BUTLER MANUFACTURING 1540 GENESSEE ST. KANSAS CITY, MO 64102			ANCHOR ROD PLAN - DETAILS	
	REV	DATE	BY	DESCRIPTION	BUILDER: Salacia Construction
					CUSTOMER:
					LOCATION: Slidell, Louisiana
					PROJECT: RV Storage - Legacy Buick GMC - Slidell
					BUILDER'S PO#:
DRAWING SCALE: NTS				 Butler Manufacturing VPC VERSION: ADVNXT 6.8	
				JOB #:	DATE: 4/5/2024
				DRAWN/CHECK:	PAGE: 1

Part	Mem	Width	Thick	WebThk.	Depth1	Depth2	Approx.Lgth	Approx.Weight	Detail	Cee Mark No
CX001	1	5.0000	.1875	.1345	1'-4"	1'-4"	21'-4"	323#		
RBX001	2	5.0000	.1875	.1345	1'-4"	9"	16'-9 1/4"	220#		
RBX002	3	5.0000	.1875	.1345	9"	10"	18'-10 3/16"	213#		
	4	5.0000	.1875	.1345	10"	9"				
RBX003	5	5.0000	.1345	.1345	9"	9"	10'-0"	98#		
RBX004	6	5.0000	.1875	.1345	9"	1'-6 7/8"	20'-0"	267#		
	7	5.0000	.1875	.1345	1'-6 7/8"	9"				
RBX003	8	5.0000	.1345	.1345	9"	9"	10'-0"	98#		
RBX005	9	5.0000	.1875	.1345	9"	10"	18'-10 3/16"	213#		
	10	5.0000	.1875	.1345	10"	9"				
RBX001	11	5.0000	.1875	.1345	9"	1'-4"	16'-9 1/4"	220#		
CX001	12	5.0000	.1875	.1345	1'-4"	1'-4"	21'-4"	323#		
EPX001	13	5.0000	.2500	.1644	10"	10"	22'-8 15/16"	330#		
EPX002	14	5.0000	.2500	.1644	1'-0"	1'-0"	24'-4 9/16"	383#		
EPX003	15	6.0000	.3750	.1644	11"	11"	22'-8 15/16"	498#		

Frame Clearances
 Horiz. Clearance between members 1(CX001) and 12(CX001): 110'-7 1/2"
 Vert. Clearance at member 1(CX001): 19'-9 3/16"
 Vert. Clearance at member 12(CX001): 19'-9 3/16"
 Vert. Clearance at member 13(EPX001): 22'-8 3/4"
 Vert. Clearance at member 14(EPX002): 24'-4 9/16"
 Vert. Clearance at member 15(EPX003): 22'-8 3/4"
 Finished Floor Elevation = 100'-0" (Unless Noted Otherwise)

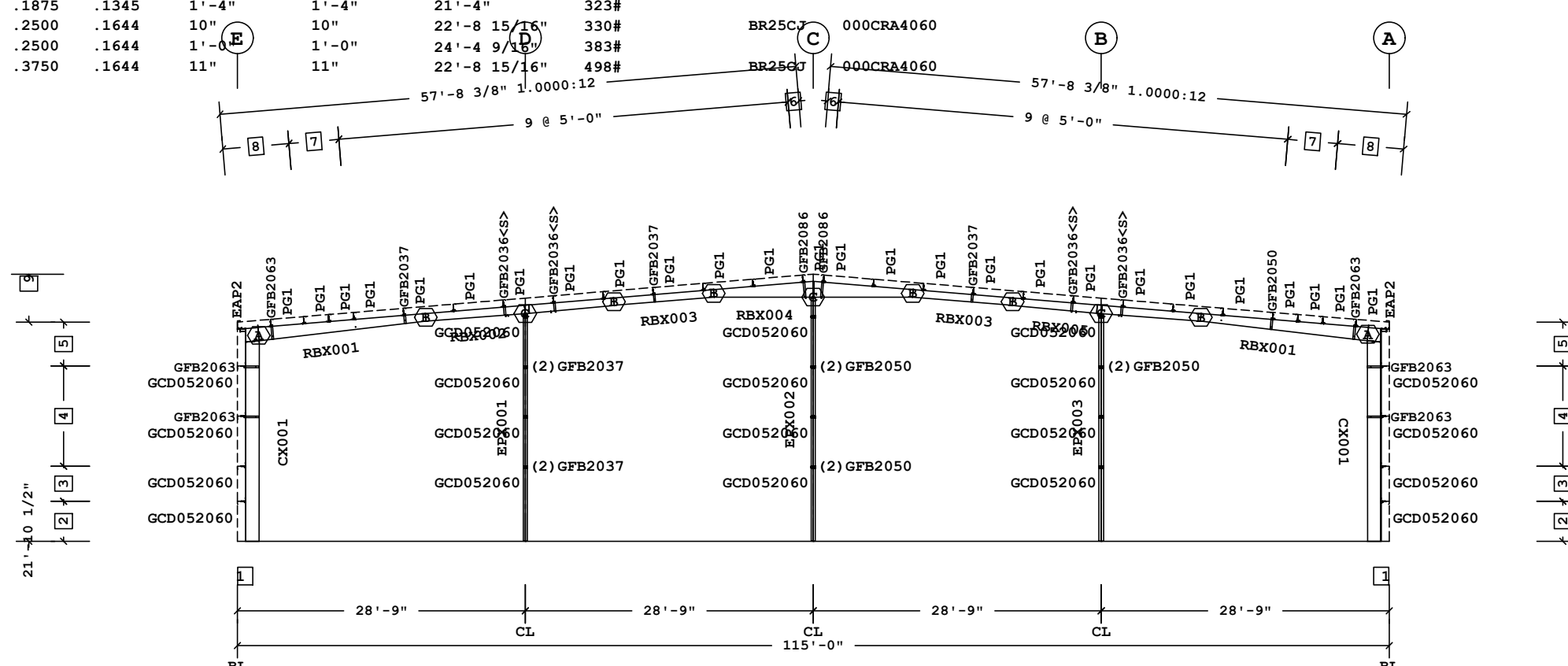

FRAME CROSS SECTION AT FRAME LINE(S) 2

- 9 26'-8" Ridge Ht.
- 8 2 @ 3'-3 11/16"
- 7 2 @ 2'-6"
- 6 1'-1"
- 5 4'-4 1/2"
- 4 2 @ 5'-0"
- 3 3'-6"
- 2 4'-0"
- 1 10"

Dimension Key

Bolt Connection & Plate Schedule

Id	Qty	Grade	Bolt Dia.	Bolt Length	Plate Thick.	Rows Out	Rows In	Tension Bolt	Washer	Part No
A	8	F1852	3/4"	2"	3/8"	2	2	Yes	Yes	0097388
B	4	F1852	3/4"	2"	3/8"	1	1	Yes	Yes	0097388
C	4	A325	1/2"	1 1/2"	3/8"	1	1			49800

<S> - (2) Washers (095872) req'd at Flange Brace to Secondary.

Shape Name = 110' x 150' Shop Expansion Wall 4, Frame 1

1. USE 1/2 X 1 1/2 A325 BOLT (49080) AND NUT (47120) W/O WASHERS. SNUG TIGHTEN BOLTS FOR ALL SECONDARY CONNECTIONS, SECONDARY CLIP CONNECTIONS, AND FLANGE BRACE CONNECTIONS, UNLESS NOTED OTHERWISE.
 2. SLOT REINFORCEMENT PLATES NEED NOT BE LOCATED ON THE SAME SIDE OF THE WEB AS THE HILLSIDE WASHER.

THE BUTLER MFG. ENGINEER'S SEAL APPLIES ONLY TO THE WORK PRODUCT OF BUTLER MFG. AND DESIGN AND PERFORMANCE REQUIREMENTS SPECIFIED BY BUTLER. THE BUTLER MFG. ENGINEER'S SEAL DOES NOT APPLY TO THE PERFORMANCE OR DESIGN OF ANY OTHER PRODUCT OR COMPONENT FURNISHED BY BUTLER EXCEPT TO ANY DESIGN OR PERFORMANCE REQUIREMENTS SPECIFIED BY BUTLER.

THIS DRAWING, INCLUDING THE INFORMATION HEREON, REMAINS THE PROPERTY OF BUTLER MFG. IT IS PROVIDED SOLELY FOR ERECTING THE BUILDING DESCRIBED IN THE APPLICABLE PURCHASE ORDER AND MAY BE REPRODUCED ONLY FOR THAT PURPOSE. IT SHALL NOT BE MODIFIED, REPRODUCED OR USED FOR ANY OTHER PURPOSE WITHOUT PRIOR WRITTEN APPROVAL OF BUTLER MFG.
 THE GENERAL CONTRACTOR AND/OR ERECTOR IS SOLELY RESPONSIBLE FOR ACCURATE GOOD QUALITY WORKMANSHIP IN ERECTING THIS BUILDING IN ACCORDANCE WITH THIS DRAWING, DETAILS REFERENCED IN THIS DRAWING, ALL APPLICABLE BUTLER MFG. ERECTION GUIDES, AND INDUSTRY STANDARDS PERTAINING TO PROPER ERECTION, INCLUDING THE CORRECT USE OF TEMPORARY BRACING.

B	BUTLER MANUFACTURING		1540 GENESSEE ST. KANSAS CITY, MO 64102		110' x 150' Shop Expansion-Frame at 2	
	REV	DATE	BY	DESCRIPTION	BUILDER: Salacia Construction	CUSTOMER:
					LOCATION: Slidell, Louisiana	PROJECT: RV Storage - Legacy Buick GMC - Slidell
					BUILDER'S PO#:	
DRAWING SCALE: NTS				BUTLER		
				Butler Manufacturing		
				VPC VERSION: ADVNXT 6.8		
				JOB #:		
				DATE: 4/5/2024		
				DRAWING CHECK:		
				PAGE:		

Frame Member Schedule								
Part	Mem	Width	Thick	WebThk.	Depth1	Depth2	Approx. Lgth	Approx. Weight
CX002	1	6.0000	.6250	.2500	1'-0"	4'-0"	21'-6 7/16"	1326#
RBX006	2	8.0000	.6250	.1875	3'-6"	1'-9"	23'-1 3/4"	1176#
	3	8.0000	.5000	.1644	1'-9"	1'-9"		
RBX007	4	6.0000	.5000	.1875	1'-9"	3'-5"	29'-11 15/16"	1239#
RBX008	5	6.0000	.5000	.1875	3'-5"	1'-9"	29'-11 15/16"	1239#
RBX009	6	8.0000	.5000	.1644	1'-9"	1'-9"	23'-1 3/4"	1176#
	7	8.0000	.6250	.1875	1'-9"	3'-6"		
CX003	8	6.0000	.6250	.2500	1'-0"	4'-0"	21'-6 7/16"	1326#

Frame Clearances
 Horiz. Clearance between members 1(CX002) and 8(CX003): 105'-3 1/2"
 Vert. Clearance at member 1(CX002): 17'-9 11/16"
 Vert. Clearance at member 8(CX003): 17'-9 11/16"
 Finished Floor Elevation = 100'-0" (Unless Noted Otherwise)

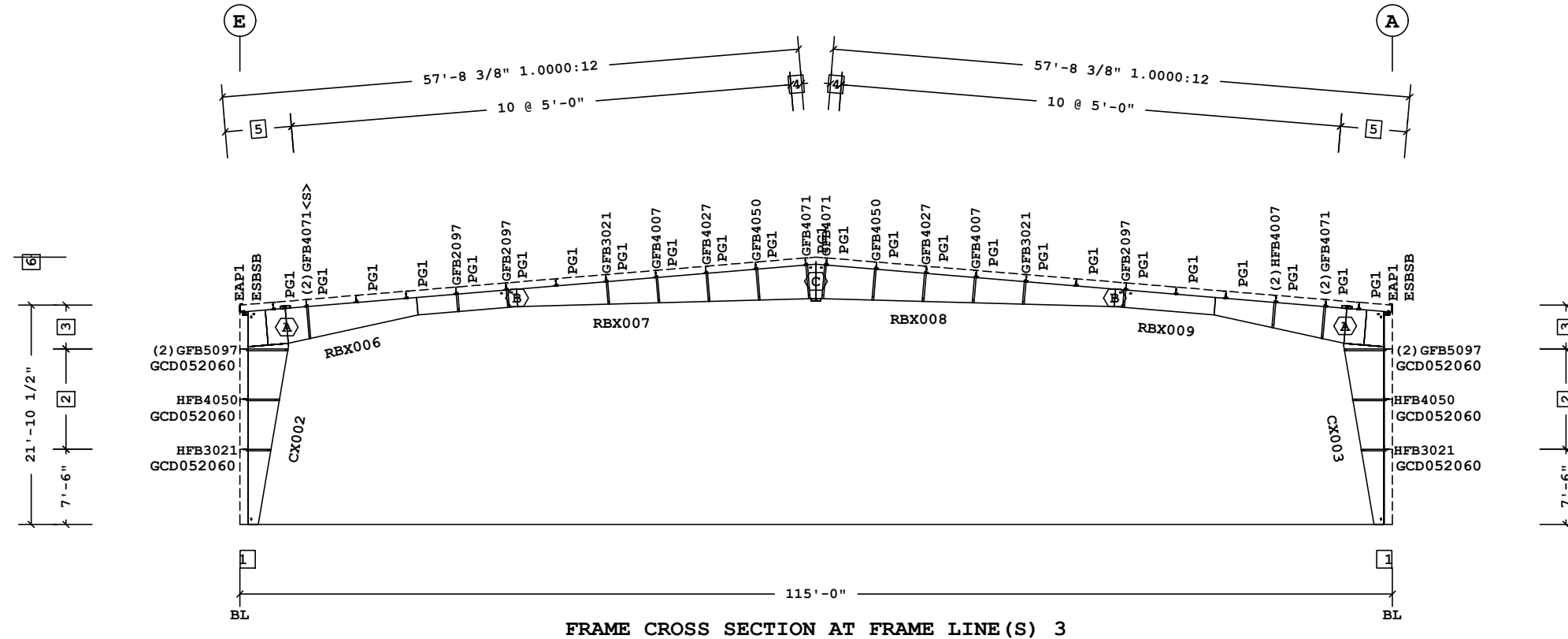

- 6 26'-8" Ridge Ht.
- 5 2 @ 3'-3 11/16"
- 4 1'-1"
- 3 4'-4 1/2"
- 2 2 @ 5'-0"
- 1 10"

□ Dimension Key

Bolt Connection & Plate Schedule

Id	Qty	Grade	Bolt Dia.	Bolt Length	Plate Thick.	Rows Out	Rows In	Tension Bolt	Washer	Part No
A	12	F1852	7/8"	3"	5/8"	4	2	Yes	Yes	0097397
B	8	F1852	3/4"	2 1/4"	1/2"	3	1	Yes	Yes	0097389
C	10	F1852	3/4"	2 1/4"	1/2"	2	3	Yes	Yes	0097389

<S> - (2) Washers (095872) req'd at Flange Brace to Secondary.

Shape Name = 110' x 150' Shop Expansion Wall 4, Frame 2

1. USE 1/2 X 1 1/2 A325 BOLT (49080) AND NUT (47120) W/O WASHERS. SNUG TIGHTEN BOLTS FOR ALL SECONDARY CONNECTIONS, SECONDARY CLIP CONNECTIONS, AND FLANGE BRACE CONNECTIONS, UNLESS NOTED OTHERWISE.
 2. SLOT REINFORCEMENT PLATES NEED NOT BE LOCATED ON THE SAME SIDE OF THE WEB AS THE HILLSIDE WASHER.

THE BUTLER MFG. ENGINEER'S SEAL APPLIES ONLY TO THE WORK PRODUCT OF BUTLER MFG. AND DESIGN AND PERFORMANCE REQUIREMENTS SPECIFIED BY BUTLER. THE BUTLER MFG. ENGINEER'S SEAL DOES NOT APPLY TO THE PERFORMANCE OR DESIGN OF ANY OTHER PRODUCT OR COMPONENT FURNISHED BY BUTLER EXCEPT TO ANY DESIGN OR PERFORMANCE REQUIREMENTS SPECIFIED BY BUTLER.

THIS DRAWING, INCLUDING THE INFORMATION HEREON, REMAINS THE PROPERTY OF BUTLER MFG. IT IS PROVIDED SOLELY FOR ERECTING THE BUILDING DESCRIBED IN THE APPLICABLE PURCHASE ORDER AND MAY BE REPRODUCED ONLY FOR THAT PURPOSE. IT SHALL NOT BE MODIFIED, REPRODUCED OR USED FOR ANY OTHER PURPOSE WITHOUT PRIOR WRITTEN APPROVAL OF BUTLER MFG.
 THE GENERAL CONTRACTOR AND/OR ERECTOR IS SOLELY RESPONSIBLE FOR ACCURATE GOOD QUALITY WORKMANSHIP IN ERECTING THIS BUILDING IN ACCORDANCE WITH THIS DRAWING, DETAILS REFERENCED IN THIS DRAWING, ALL APPLICABLE BUTLER MFG. ERECTION GUIDES, AND INDUSTRY STANDARDS PERTAINING TO PROPER ERECTION, INCLUDING THE CORRECT USE OF TEMPORARY BRACING.

B	BUTLER MANUFACTURING 1540 GENESSEE ST. KANSAS CITY, MO 64102		110' x 150' Shop Expansion-Frame at 3	
	REV:	DATE:	BY:	DESCRIPTION:
	BUILDER: Salacia Construction		CUSTOMER:	
	LOCATION: Slidell, Louisiana		PROJECT: RV Storage - Legacy Buick GMC - Slidell	
DRAWING SCALE: NTS		BUILDER'S PO#:		 Butler Manufacturing VPC VERSION: ADVNXT 6.8
			JOB #:	DATE: 4/5/2024
			DRAWING CHECK:	PAGE: 1

Frame Member Schedule								
Part	Mem	Width	Thick	WebThk.	Depth1	Depth2	Approx. Lgth	Approx. Weight
CX004	1	6.0000	.6250	.2500	1'-0"	4'-1"	21'-6 9/16"	1342#
RBX010	2	8.0000	.5000	.2500	3'-7"	1'-10"	23'-0 13/16"	1139#
	3	8.0000	.3750	.1875	1'-10"	1'-10"		
RBX011	4	6.0000	.6250	.1875	1'-10"	3'-6"	30'-0"	1405#
RBX012	5	6.0000	.6250	.1875	3'-6"	1'-9"	30'-0"	1396#
RBX013	6	8.0000	.3750	.2500	1'-9"	1'-9"	23'-0 13/16"	1172#
	7	8.0000	.5000	.2500	1'-9"	3'-7"		
CX005	8	6.0000	.6250	.2500	1'-0"	4'-1"	21'-6 9/16"	1342#

Frame Clearances
 Horiz. Clearance between members 1(CX004) and 8(CX005): 105'-1 1/2"
 Vert. Clearance at member 1(CX004): 17'-8 3/4"
 Vert. Clearance at member 8(CX005): 17'-8 3/4"
 Finished Floor Elevation = 100'-0" (Unless Noted Otherwise)

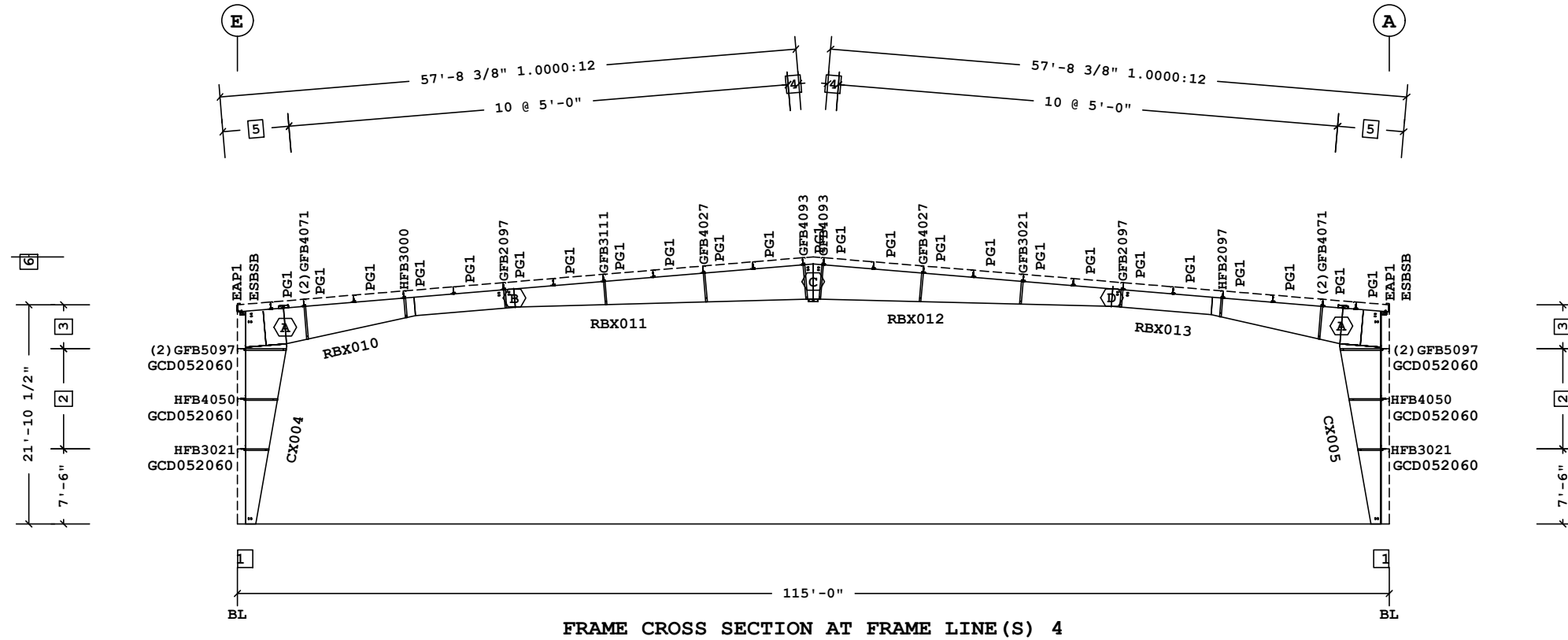

- 6 26'-8" Ridge Ht.
 - 5 2 @ 3'-3 11/16"
 - 4 1'-1"
 - 3 4'-4 1/2"
 - 2 2 @ 5'-0"
 - 1 10"
- Dimension Key

Bolt Connection & Plate Schedule

Id	Qty	Grade	Bolt Dia.	Bolt Length	Plate Thick.	Rows Out	Rows In	Tension Bolt	Washer	Part No
A	12	F1852	7/8"	3"	5/8"	4	2	Yes	Yes	0097397
B	8	F1852	3/4"	2 1/4"	1/2"	3	1	Yes	Yes	0097389
C	14	F1852	3/4"	2 1/4"	1/2"	3	4	Yes	Yes	0097389
D	6	F1852	3/4"	2 1/4"	1/2"	2	1	Yes	Yes	0097389

Shape Name = 110' x 150' Shop Expansion Wall 4, Frame 3

1. USE 1/2 X 1 1/2 A325 BOLT (49080) AND NUT (47120) W/O WASHERS. SNUG TIGHTEN BOLTS FOR ALL SECONDARY CONNECTIONS, SECONDARY CLIP CONNECTIONS, AND FLANGE BRACE CONNECTIONS, UNLESS NOTED OTHERWISE.
 2. SLOT REINFORCEMENT PLATES NEED NOT BE LOCATED ON THE SAME SIDE OF THE WEB AS THE HILLSIDE WASHER.

THE BUTLER MFG. ENGINEER'S SEAL APPLIES ONLY TO THE WORK PRODUCT OF BUTLER MFG. AND DESIGN AND PERFORMANCE REQUIREMENTS SPECIFIED BY BUTLER. THE BUTLER MFG. ENGINEER'S SEAL DOES NOT APPLY TO THE PERFORMANCE OR DESIGN OF ANY OTHER PRODUCT OR COMPONENT FURNISHED BY BUTLER EXCEPT TO ANY DESIGN OR PERFORMANCE REQUIREMENTS SPECIFIED BY BUTLER.

THIS DRAWING, INCLUDING THE INFORMATION HEREON, REMAINS THE PROPERTY OF BUTLER MFG. IT IS PROVIDED SOLELY FOR ERRECTING THE BUILDING DESCRIBED IN THE APPLICABLE PURCHASE ORDER AND MAY BE REPRODUCED ONLY FOR THAT PURPOSE. IT SHALL NOT BE MODIFIED, REPRODUCED OR USED FOR ANY OTHER PURPOSE WITHOUT PRIOR WRITTEN APPROVAL OF BUTLER MFG.
 THE GENERAL CONTRACTOR AND/OR ERECTOR IS SOLELY RESPONSIBLE FOR ACCURATE GOOD QUALITY WORKMANSHIP IN ERRECTING THIS BUILDING IN ACCORDANCE WITH THIS DRAWING, DETAILS REFERENCED IN THIS DRAWING, ALL APPLICABLE BUTLER MFG. ERECTION GUIDES, AND INDUSTRY STANDARDS PERTAINING TO PROPER ERECTION, INCLUDING THE CORRECT USE OF TEMPORARY BRACING.

B	BUTLER MANUFACTURING 1540 GENESSEE ST. KANSAS CITY, MO 64102		110' x 150' Shop Expansion-Frame at 4	
	REV	DATE	BY	DESCRIPTION
	BUILDER: Salacia Construction		CUSTOMER:	
	LOCATION: Slidell, Louisiana		PROJECT: RV Storage - Legacy Buick GMC - Slidell	
DRAWING SCALE: NTS		BUILDER'S PO#:		 Butler Manufacturing VPC VERSION: ADVNXT 6.8
			JOB #:	DATE: 4/5/2024
			DRAWING CHECK:	PAGE: 1

Part	Mem	Width	Thick	WebThk.	Depth1	Depth2	Approx. Lgth	Approx. Weight
CX002	1	6.0000	.6250	.2500	1'-0"	4'-0"	21'-6 7/16"	1326#
RBX006	2	8.0000	.6250	.1875	3'-6"	1'-9"	23'-1 3/4"	1176#
	3	8.0000	.5000	.1644	1'-9"	1'-9"		
RBX007	4	6.0000	.5000	.1875	1'-9"	3'-5"	29'-11 15/16"	1239#
RBX008	5	6.0000	.5000	.1875	3'-5"	1'-9"	29'-11 15/16"	1239#
RBX009	6	8.0000	.5000	.1644	1'-9"	1'-9"	23'-1 3/4"	1176#
	7	8.0000	.6250	.1875	1'-9"	3'-6"		
CX003	8	6.0000	.6250	.2500	1'-0"	4'-0"	21'-6 7/16"	1326#

Frame Clearances
 Horiz. Clearance between members 1(CX002) and 8(CX003): 105'-3 1/2"
 Vert. Clearance at member 1(CX002): 17'-9 11/16"
 Vert. Clearance at member 8(CX003): 17'-9 11/16"
 Finished Floor Elevation = 100'-0" (Unless Noted Otherwise)

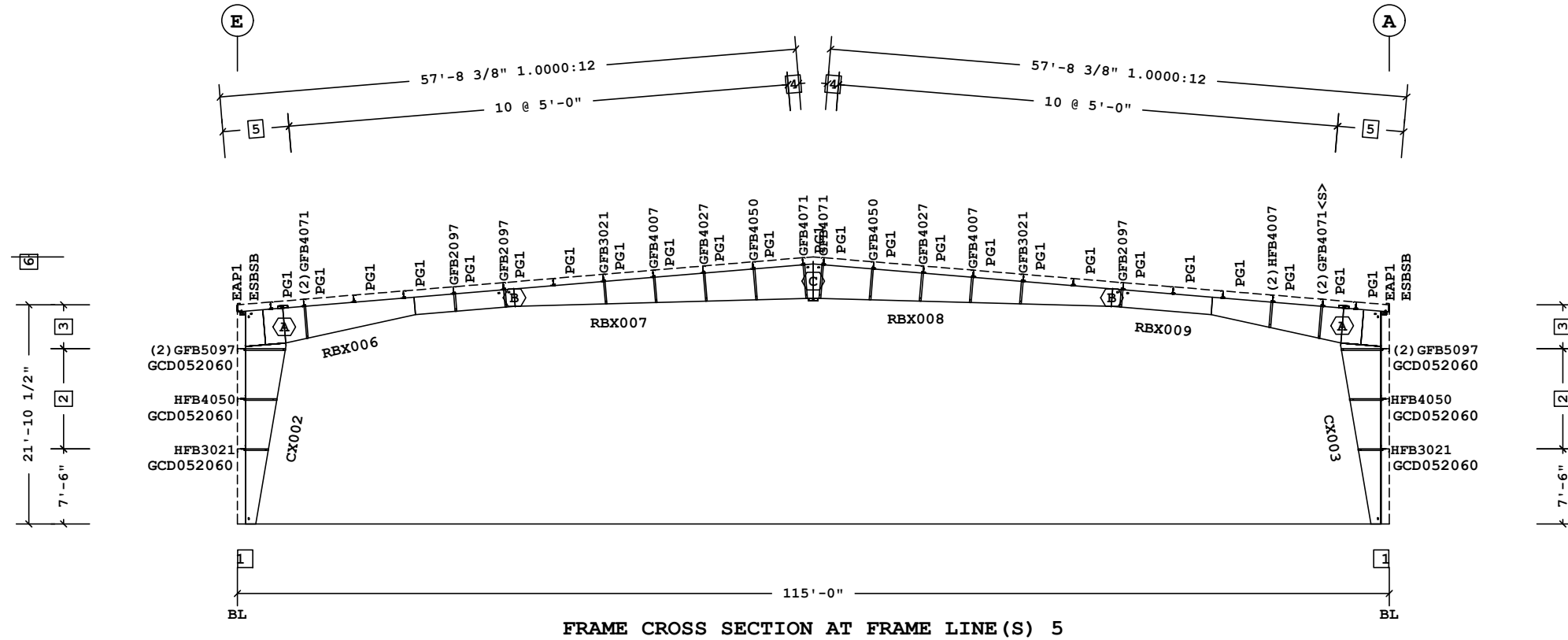

FRAME CROSS SECTION AT FRAME LINE(S) 5

- 6 26'-8" Ridge Ht.
- 5 2 @ 3'-3 11/16"
- 4 1'-1"
- 3 4'-4 1/2"
- 2 2 @ 5'-0"
- 1 10"

Dimension Key

Bolt Connection & Plate Schedule

Id	Qty	Grade	Bolt Dia.	Bolt Length	Plate Thick.	Rows Out	Rows In	Tension Bolt	Washer	Part No
A	12	F1852	7/8"	3"	5/8"	4	2	Yes	Yes	0097397
B	8	F1852	3/4"	2 1/4"	1/2"	3	1	Yes	Yes	0097389
C	10	F1852	3/4"	2 1/4"	1/2"	2	3	Yes	Yes	0097389

<S> - (2) Washers (095872) req'd at Flange Brace to Secondary.

Shape Name = 110' x 150' Shop Expansion Wall 4, Frame 4

1. USE 1/2 X 1 1/2 A325 BOLT (49080) AND NUT (47120) W/O WASHERS. SNUG TIGHTEN BOLTS FOR ALL SECONDARY CONNECTIONS, SECONDARY CLIP CONNECTIONS, AND FLANGE BRACE CONNECTIONS, UNLESS NOTED OTHERWISE.
 2. SLOT REINFORCEMENT PLATES NEED NOT BE LOCATED ON THE SAME SIDE OF THE WEB AS THE HILLSIDE WASHER.

THE BUTLER MFG. ENGINEER'S SEAL APPLIES ONLY TO THE WORK PRODUCT OF BUTLER MFG. AND DESIGN AND PERFORMANCE REQUIREMENTS SPECIFIED BY BUTLER. THE BUTLER MFG. ENGINEER'S SEAL DOES NOT APPLY TO THE PERFORMANCE OR DESIGN OF ANY OTHER PRODUCT OR COMPONENT FURNISHED BY BUTLER EXCEPT TO ANY DESIGN OR PERFORMANCE REQUIREMENTS SPECIFIED BY BUTLER.

THIS DRAWING, INCLUDING THE INFORMATION HEREON, REMAINS THE PROPERTY OF BUTLER MFG. IT IS PROVIDED SOLELY FOR ERRECTING THE BUILDING DESCRIBED IN THE APPLICABLE PURCHASE ORDER AND MAY BE REPRODUCED ONLY FOR THAT PURPOSE. IT SHALL NOT BE MODIFIED, REPRODUCED OR USED FOR ANY OTHER PURPOSE WITHOUT PRIOR WRITTEN APPROVAL OF BUTLER MFG.
 THE GENERAL CONTRACTOR AND/OR ERECTOR IS SOLELY RESPONSIBLE FOR ACCURATE GOOD QUALITY WORKMANSHIP IN ERRECTING THIS BUILDING IN ACCORDANCE WITH THIS DRAWING, DETAILS REFERENCED IN THIS DRAWING, ALL APPLICABLE BUTLER MFG. ERECTION GUIDES, AND INDUSTRY STANDARDS PERTAINING TO PROPER ERECTION, INCLUDING THE CORRECT USE OF TEMPORARY BRACING.

B	BUTLER MANUFACTURING		1540 GENESSEE ST. KANSAS CITY, MO 64102		110' x 150' Shop Expansion-Frame at 5	
	REV	DATE	BY	DESCRIPTION	BUILDER: Salacia Construction	CUSTOMER:
					LOCATION: Slidell, Louisiana	PROJECT: RV Storage - Legacy Buick GMC - Slidell
					BUILDER'S PO#:	
DRAWING SCALE: NTS				 Butler Manufacturing VPC VERSION: ADVNXT 6.8		
				JOB #:	DATE: 4/5/2024	DRAWING CHECK: /
				PAGE:		

Secondary Part Schedule

Mark	Part	Thick.	Depth	Lap	Detail
E1	10E2602414DVB31	0.0790	10"		RS12PF, RS12PE, RS12PJ
E2	10E2602414DDB31	0.0790	10"		RS12PE, RS12PJ
J7	00108JS0506017	0.0600	8 1/2"		BR09HF
P1	08Z3002412V5B3	0.0980	8 1/2"	3'-10 1/2"	RS02T1, RS01T1
P2	08Z3002414V5B3	0.0790	8 1/2"	3'-10 1/2"	RS02T1, RS01T1
P3	00108ZS1302417A3	0.0600	8 1/2"	3'-10 1/2"	RS02T1
P4	08Z300241433B2	0.0790	8 1/2"	1'-10 1/2"	RS01T1
P5	08Z300241633B2	0.0680	8 1/2"	1'-10 1/2"	RS01T1

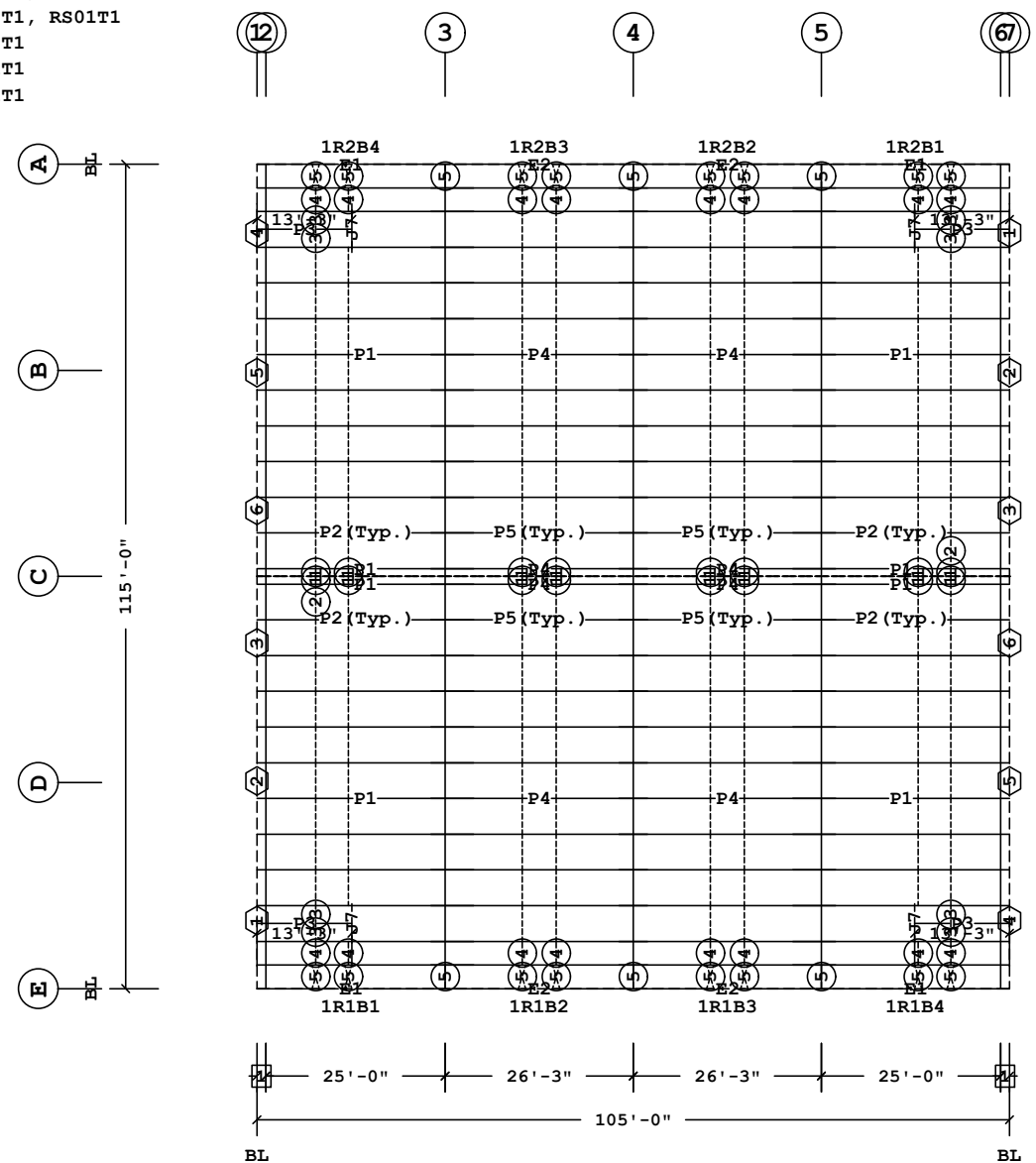

Secondary Bracing Schedule

Id	Qty	Mark No	Spacing
1	16	CPBRB010510	1'-1"
2	152	CPBB050108 (Typ.)	5'-0"
3	8	CPBB020708	2'-6"
4	16	CPBB030504	3'-3 11/16"
5	38	PBA0307	3'-3 11/16"

See SED:

BR09PK, BR09RY, BR09RZ, BR09JG, BR09PH
BR09JR, BR09JH, BR09K5, BR09K2

Part Mark Key

1	002SGA19007
2	002SGA19114
3	002SGA18064
4	001SGA19007
5	001SGA19114
6	001SGA18064

1 1'-3"

Dimension Key

Shape Name = 110' x 150' Shop Expansion

ROOF SECONDARY PLAN

1. UNLESS NOTED, USE 1/2 X 1 1/2 A325T BOLT (49080) AND NUT (47120) W/O WASHERS. SNUG TIGHTEN BOLTS FOR ALL SECONDARY CONNECTIONS.
2. FLANGE BRACES ARE AN INTEGRAL PART OF THE STABILITY OF THE STRUCTURAL SYSTEM AND MUST BE PROPERLY INSTALLED PRIOR TO ERECTION OF WALL AND ROOF SHEETS.
3. REMOVAL OR ALTERATION OF ANY COMPONENT IS PROHIBITED.

THE BUTLER MFG. ENGINEER'S SEAL APPLIES ONLY TO THE WORK PRODUCT OF BUTLER MFG. AND DESIGN AND PERFORMANCE REQUIREMENTS SPECIFIED BY BUTLER. THE BUTLER MFG. ENGINEER'S SEAL DOES NOT APPLY TO THE PERFORMANCE OR DESIGN OF ANY OTHER PRODUCT OR COMPONENT FURNISHED BY BUTLER EXCEPT TO ANY DESIGN OR PERFORMANCE REQUIREMENTS SPECIFIED BY BUTLER.

THIS DRAWING, INCLUDING THE INFORMATION HEREON, REMAINS THE PROPERTY OF BUTLER MFG. IT IS PROVIDED SOLELY FOR ERECTING THE BUILDING DESCRIBED IN THE APPLICABLE PURCHASE ORDER AND MAY BE REPRODUCED ONLY FOR THAT PURPOSE. IT SHALL NOT BE MODIFIED, REPRODUCED OR USED FOR ANY OTHER PURPOSE WITHOUT PRIOR WRITTEN APPROVAL OF BUTLER MFG.
THE GENERAL CONTRACTOR AND/OR ERECTOR IS SOLELY RESPONSIBLE FOR ACCURATE GOOD QUALITY WORKMANSHIP IN ERECTING THIS BUILDING IN ACCORDANCE WITH THIS DRAWING, DETAILS REFERENCED IN THIS DRAWING, ALL APPLICABLE BUTLER MFG. ERECTION GUIDES, AND INDUSTRY STANDARDS PERTAINING TO PROPER ERECTION, INCLUDING THE CORRECT USE OF TEMPORARY BRACING.

B	BUTLER MANUFACTURING 1540 GENESSEE ST. KANSAS CITY, MO 64102		ROOF SECONDARY PLAN	
	REV	DATE	BY	DESCRIPTION
BUILDER: Salacia Construction		CUSTOMER:		JOB #:
LOCATION: Slidell, Louisiana		PROJECT: RV Storage - Legacy Buick GMC - Slidell		
DRAWING SCALE: NTS		BUILDER'S PO#:		DATE: 4/5/2024
				DRAWN/CHECK: /
				PAGE:



Secondary Part Schedule

Mark	Part	Thick.	Depth	Lap	Detail
G1	JCP051140	0.0600	10"		WS12N2, WS20F2
G2	10Z2908413U302	0.0880	10"	1'-10 1/2"	WS12N2, WS01V3
G3	00110ZS011141702	0.0600	10"		WS20F2
G4	10Z34084144402	0.0790	10"	2'-10 1/2"	WS01V3
G5	00210ZS331141602	0.0680	10"	2'-10 1/2"	WS01V3, WS20F2
G6	10Z34084164402	0.0680	10"	2'-10 1/2"	WS01V3
G7	00410ZS070541702	0.0600	10"		WS12N2, WS20F2, BR10F5
G8	00310ZS300841602	0.0680	10"	2'-10 1/2"	WS12N2, BR10F5, WS01V3
G9	10Z3008416U402	0.0680	10"	2'-10 1/2"	WS12N2, WS01V3
H1	00110JS2500017	0.0600	10"		WS20F9
J1	00610JS1702213	0.0880	10"		WS20F9, WS20F2, WS20B2, WS20B8
J2	00210JS1702213	0.0880	10"		WS20F9, WS20F2, WS20B2, WS20B8
J3	00310JS1702214	0.0790	10"		WS20F9, WS20F2, WS20B2, WS20B8
J4	00410JS0702217	0.0600	10"		BR10F5, WS20B2, WS20B8

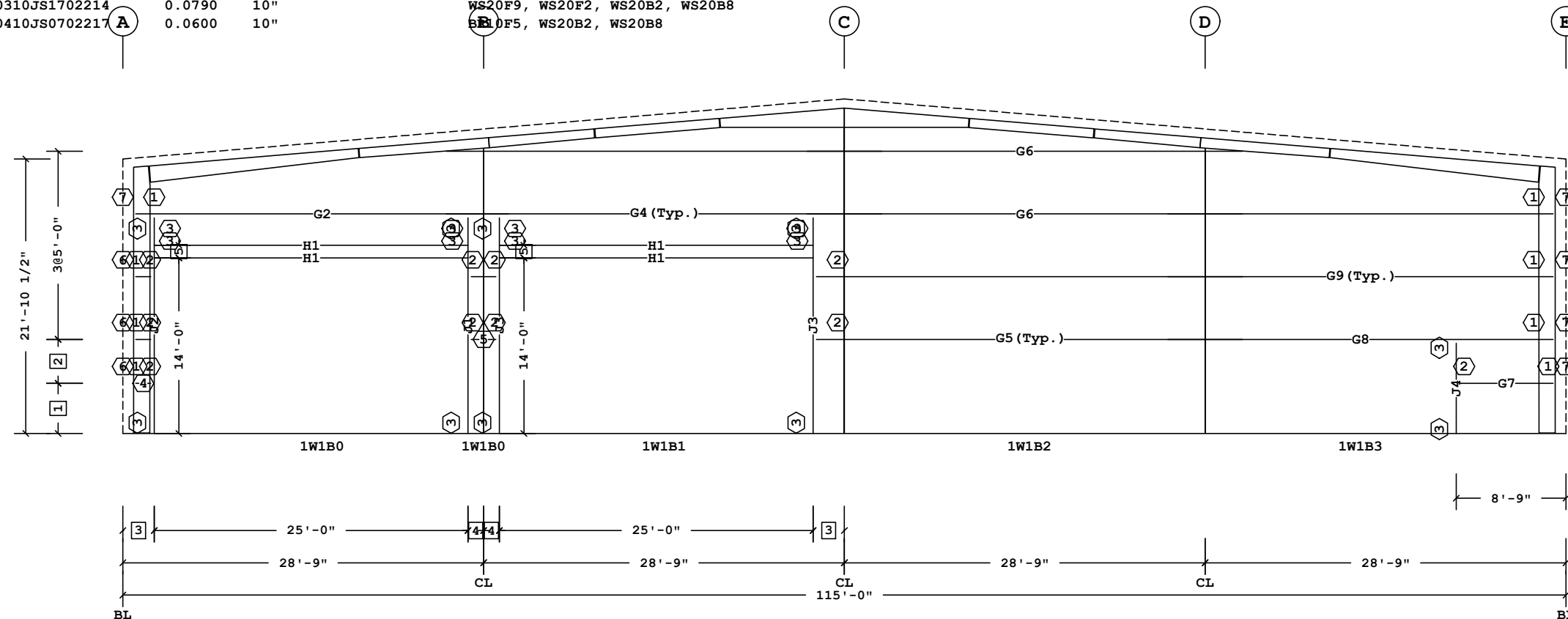

SECONDARY ELEVATION AT 1

7	GFAP1084	
6	GFAP2084	
5	1'-0"	5 G3 (Typ.)
4	1'-3"	4 G1 (Typ.)
3	2'-6"	3 PG1
2	3'-6"	2 JTG4
1	4'-0"	1 VCC08403104

Dimension Key Part Mark Key

Shape Name = 110' x 150' Shop Expansion, Wall = 1

- UNLESS NOTED, USE 1/2 X 1 1/2 A325T BOLT (49080) AND NUT (47120) W/O WASHERS. SNUG TIGHTEN BOLTS FOR ALL SECONDARY CONNECTIONS.
- FLANGE BRACES ARE AN INTEGRAL PART OF THE STABILITY OF THE STRUCTURAL SYSTEM AND MUST BE PROPERLY INSTALLED PRIOR TO ERECTION OF WALL AND ROOF SHEETS.
- REMOVAL OR ALTERATION OF ANY COMPONENT IS PROHIBITED.

THE BUTLER MFG. ENGINEER'S SEAL APPLIES ONLY TO THE WORK PRODUCT OF BUTLER MFG. AND DESIGN AND PERFORMANCE REQUIREMENTS SPECIFIED BY BUTLER. THE BUTLER MFG. ENGINEER'S SEAL DOES NOT APPLY TO THE PERFORMANCE OR DESIGN OF ANY OTHER PRODUCT OR COMPONENT FURNISHED BY BUTLER EXCEPT TO ANY DESIGN OR PERFORMANCE REQUIREMENTS SPECIFIED BY BUTLER.

THIS DRAWING, INCLUDING THE INFORMATION HEREON, REMAINS THE PROPERTY OF BUTLER MFG. IT IS PROVIDED SOLELY FOR ERECTING THE BUILDING DESCRIBED IN THE APPLICABLE PURCHASE ORDER AND MAY BE REPRODUCED ONLY FOR THAT PURPOSE. IT SHALL NOT BE MODIFIED, REPRODUCED OR USED FOR ANY OTHER PURPOSE WITHOUT PRIOR WRITTEN APPROVAL OF BUTLER MFG.

THE GENERAL CONTRACTOR AND/OR ERECTOR IS SOLELY RESPONSIBLE FOR ACCURATE GOOD QUALITY WORKMANSHIP IN ERECTING THIS BUILDING IN ACCORDANCE WITH THIS DRAWING, DETAILS REFERENCED IN THIS DRAWING, ALL APPLICABLE BUTLER MFG. ERECTION GUIDES, AND INDUSTRY STANDARDS PERTAINING TO PROPER ERECTION, INCLUDING THE CORRECT USE OF TEMPORARY BRACING.

B	BUTLER MANUFACTURING 1540 GENESSEE ST. KANSAS CITY, MO 64102			110' x 150' Shop Expansion-Secondary at 1	
	REV.	DATE	BY	DESCRIPTION	BUILDER: Salacia Construction
					CUSTOMER:
					LOCATION: Slidell, Louisiana
					PROJECT: RV Storage - Legacy Buick GMC - Slidell
					BUILDER'S PO#:
DRAWING SCALE: NTS				 Butler Manufacturing VPC VERSION: ADVNXT 6.8	
				JOB #:	DATE: 4/5/2024
				DRAWN/CHECK:	PAGE: 1

Secondary Part Schedule

Mark	Part	Thick.	Depth	Lap	Detail
G10	00610ZS080541702	0.0600	10"		WS12N2, WS20F2, BR10F5
G11	00510ZS280241702	0.0600	10"	1'-10 1/2"	WS12N2, WS01V3
G12	10Z2802417V302	0.0600	10"	1'-10 1/2"	WS12N2, WS01V3
G13	10Z30024173302	0.0600	10"	1'-10 1/2"	WS01V3
G14	00710ZS280241702	0.0600	10"	1'-10 1/2"	WS12N2, BR10F5, WS01V3
J4	00410JS0702217	0.0600	10"		BR10F5, WS20B2, WS20B8
J5	00510JS0702217	0.0600	10"		BR10F5, WS20B2, WS20B8

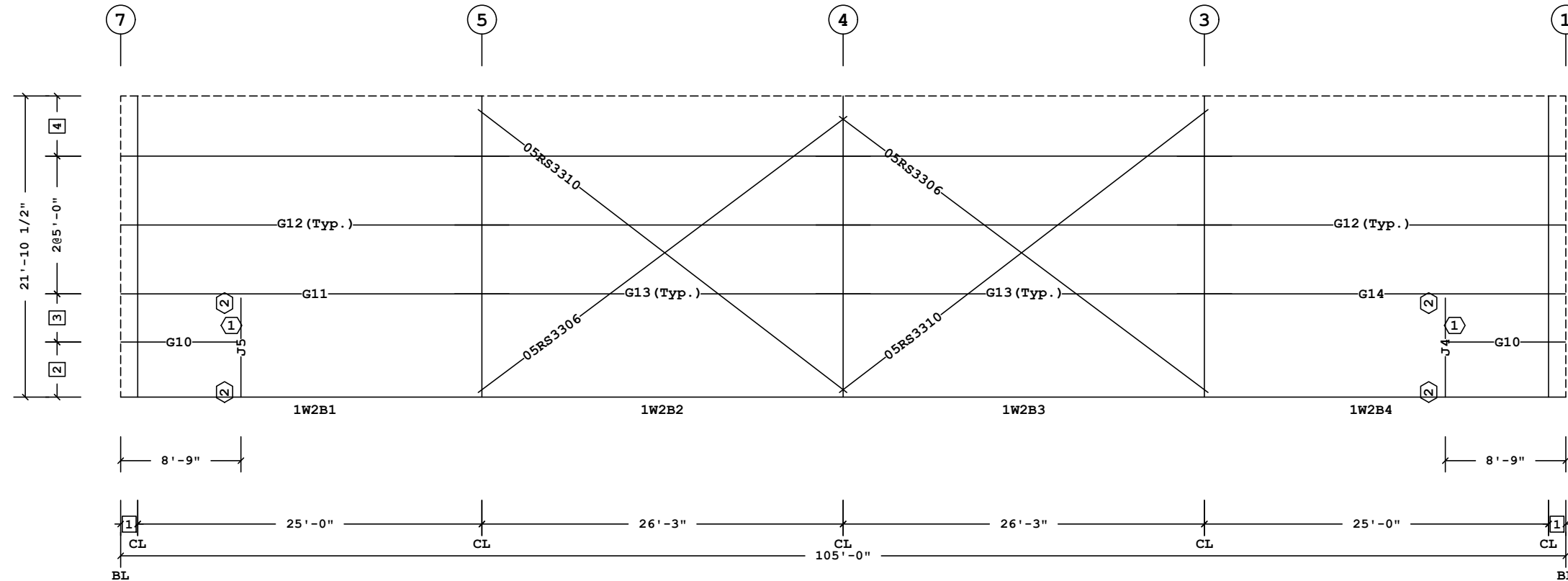

SECONDARY ELEVATION AT A

Bracing Part Schedule

Part	Qty	Length	Detail
05RS3306	2	33'-6"	BR01G2
05RS3310	2	33'-10"	BR01G2

4	4'-4 1/2"	3	0543333
3	3'-6"	2	PG1
2	4'-0"	1	JTG4
1	1'-3"		

□ Dimension Key ◻ Part Mark Key

Shape Name = 110' x 150' Shop Expansion, Wall = 2

- UNLESS NOTED, USE 1/2 X 1 1/2 A325T BOLT (49080) AND NUT (47120) W/O WASHERS. SNUG TIGHTEN BOLTS FOR ALL SECONDARY CONNECTIONS.
- FLANGE BRACES ARE AN INTEGRAL PART OF THE STABILITY OF THE STRUCTURAL SYSTEM AND MUST BE PROPERLY INSTALLED PRIOR TO ERECTION OF WALL AND ROOF SHEETS.
- REMOVAL OR ALTERATION OF ANY COMPONENT IS PROHIBITED.

THE BUTLER MFG. ENGINEER'S SEAL APPLIES ONLY TO THE WORK PRODUCT OF BUTLER MFG. AND DESIGN AND PERFORMANCE REQUIREMENTS SPECIFIED BY BUTLER. THE BUTLER MFG. ENGINEER'S SEAL DOES NOT APPLY TO THE PERFORMANCE OR DESIGN OF ANY OTHER PRODUCT OR COMPONENT FURNISHED BY BUTLER EXCEPT TO ANY DESIGN OR PERFORMANCE REQUIREMENTS SPECIFIED BY BUTLER.

THIS DRAWING, INCLUDING THE INFORMATION HEREON, REMAINS THE PROPERTY OF BUTLER MFG. IT IS PROVIDED SOLELY FOR ERECTING THE BUILDING DESCRIBED IN THE APPLICABLE PURCHASE ORDER AND MAY BE REPRODUCED ONLY FOR THAT PURPOSE. IT SHALL NOT BE MODIFIED, REPRODUCED OR USED FOR ANY OTHER PURPOSE WITHOUT PRIOR WRITTEN APPROVAL OF BUTLER MFG.

THE GENERAL CONTRACTOR AND/OR ERECTOR IS SOLELY RESPONSIBLE FOR ACCURATE GOOD QUALITY WORKMANSHIP IN ERECTING THIS BUILDING IN ACCORDANCE WITH THIS DRAWING, DETAILS REFERENCED IN THIS DRAWING, ALL APPLICABLE BUTLER MFG. ERECTION GUIDES, AND INDUSTRY STANDARDS PERTAINING TO PROPER ERECTION, INCLUDING THE CORRECT USE OF TEMPORARY BRACING.

B BUTLER MANUFACTURING 1540 GENESSEE ST. KANSAS CITY, MO 64102				110' x 150' Shop Expansion-Secondary at A	
REV	DATE	BY	DESCRIPTION	BUILDER: Salacia Construction	JOB #:
				CUSTOMER:	DATE: 4/5/2024
				LOCATION: Slidell, Louisiana	DRAWN/CHECK:
				PROJECT: RV Storage - Legacy Buick GMC - Slidell	PAGE: 1
DRAWING SCALE: NTS				BUILDER'S PO#:	PAGE: 1



Butler Manufacturing
VPC VERSION: ADVNXT 6.8

Secondary Part Schedule

Mark	Part	Thick.	Depth	Lap	Detail
G15	00810ZS300841602	0.0680	10"	2'-10 1/2"	WS12N2, BR10F5, WS01V3
G16	00910ZS330541602	0.0680	10"	2'-10 1/2"	WS20F2, WS01V3
G17	01210ZS030541702	0.0600	10"		WS12N2, WS20F2
G18	10Z2908414U302	0.0790	10"	1'-10 1/2"	WS12N2, WS01V3
G4	10Z34084144402	0.0790	10"	2'-10 1/2"	WS01V3
G6	10Z34084164402	0.0680	10"	2'-10 1/2"	WS01V3
G7	00410ZS070541702	0.0600	10"		WS12N2, WS20F2, BR10F5
G9	10Z3008416U402	0.0680	10"	2'-10 1/2"	WS12N2, WS01V3
H1	00110JS2500017	0.0600	10"		WS20F9
J3	00310JS1702214	0.0790	10"		WS20F9, WS20F2, WS20B2, WS20B8
J5	00510JS0702217	0.0600	10"		BR10F5, WS20B2, WS20B8
J6	00710JS1702214	0.0790	10"		WS20F9, WS20F2, WS20B2, WS20B8

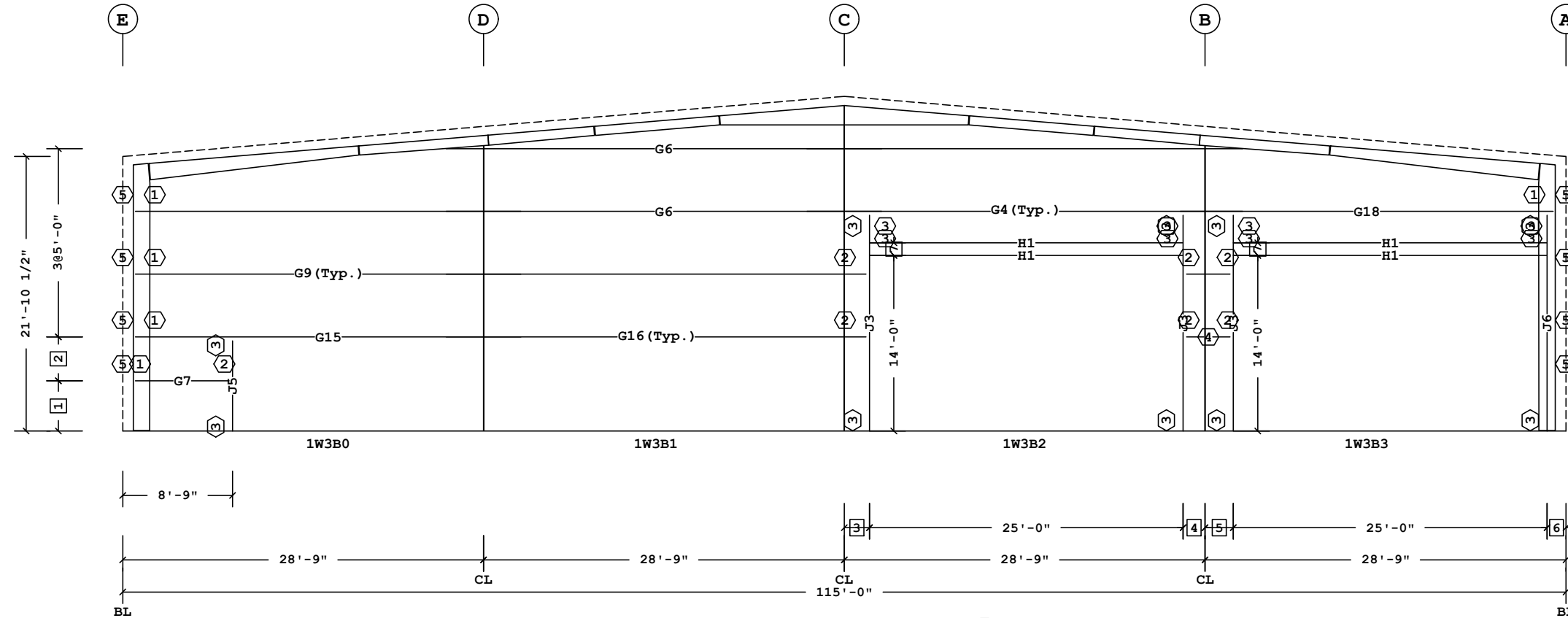

SECONDARY ELEVATION AT 7

7	1'-0"	5	GFAP1084
6	1'-6"	4	G17 (Typ.)
5	2'-3"	3	PG1
4	1'-9"	2	JTG4
3	2'-0"	1	VCC08403104
2	3'-6"		
1	4'-0"		

Dimension Key Part Mark Key

Shape Name = 110' x 150' Shop Expansion, Wall = 3

- UNLESS NOTED, USE 1/2 X 1 1/2 A325T BOLT (49080) AND NUT (47120) W/O WASHERS. SNUG TIGHTEN BOLTS FOR ALL SECONDARY CONNECTIONS.
- FLANGE BRACES ARE AN INTEGRAL PART OF THE STABILITY OF THE STRUCTURAL SYSTEM AND MUST BE PROPERLY INSTALLED PRIOR TO ERECTION OF WALL AND ROOF SHEETS.
- REMOVAL OR ALTERATION OF ANY COMPONENT IS PROHIBITED.

THE BUTLER MFG. ENGINEER'S SEAL APPLIES ONLY TO THE WORK PRODUCT OF BUTLER MFG. AND DESIGN AND PERFORMANCE REQUIREMENTS SPECIFIED BY BUTLER. THE BUTLER MFG. ENGINEER'S SEAL DOES NOT APPLY TO THE PERFORMANCE OR DESIGN OF ANY OTHER PRODUCT OR COMPONENT FURNISHED BY BUTLER EXCEPT TO ANY DESIGN OR PERFORMANCE REQUIREMENTS SPECIFIED BY BUTLER.

THIS DRAWING, INCLUDING THE INFORMATION HEREON, REMAINS THE PROPERTY OF BUTLER MFG. IT IS PROVIDED SOLELY FOR ERECTING THE BUILDING DESCRIBED IN THE APPLICABLE PURCHASE ORDER AND MAY BE REPRODUCED ONLY FOR THAT PURPOSE. IT SHALL NOT BE MODIFIED, REPRODUCED OR USED FOR ANY OTHER PURPOSE WITHOUT PRIOR WRITTEN APPROVAL OF BUTLER MFG.

THE GENERAL CONTRACTOR AND/OR ERECTOR IS SOLELY RESPONSIBLE FOR ACCURATE GOOD QUALITY WORKMANSHIP IN ERECTING THIS BUILDING IN ACCORDANCE WITH THIS DRAWING, DETAILS REFERENCED IN THIS DRAWING, ALL APPLICABLE BUTLER MFG. ERECTION GUIDES, AND INDUSTRY STANDARDS PERTAINING TO PROPER ERECTION, INCLUDING THE CORRECT USE OF TEMPORARY BRACING.

B	BUTLER MANUFACTURING 1540 GENESSEE ST. KANSAS CITY, MO 64102			110' x 150' Shop Expansion-Secondary at 7	
	REV.	DATE	BY	DESCRIPTION	BUILDER: Salacia Construction
					CUSTOMER:
					LOCATION: Slidell, Louisiana
					PROJECT: RV Storage - Legacy Buick GMC - Slidell
					BUILDER'S PO#:
DRAWING SCALE: NTS					
				BUTLER Butler Manufacturing VPC VERSION: ADVNXT 6.8	
				JOB #: DATE: 4/5/2024 DRAWING CHECK: / PAGE:	

Secondary Part Schedule

Mark	Part	Thick.	Depth	Lap	Detail
G10	00610ZS080541702	0.0600	10"		WS12N2, WS20F2, BR10F5
G11	00510ZS280241702	0.0600	10"	1'-10 1/2"	WS12N2, WS01V3
G12	10Z2802417V302	0.0600	10"	1'-10 1/2"	WS12N2, WS01V3
G13	10Z30024173302	0.0600	10"	1'-10 1/2"	WS01V3
G14	00710ZS280241702	0.0600	10"	1'-10 1/2"	WS12N2, BR10F5, WS01V3
J4	00410JS0702217	0.0600	10"		BR10F5, WS20B2, WS20B8
J5	00510JS0702217	0.0600	10"		BR10F5, WS20B2, WS20B8

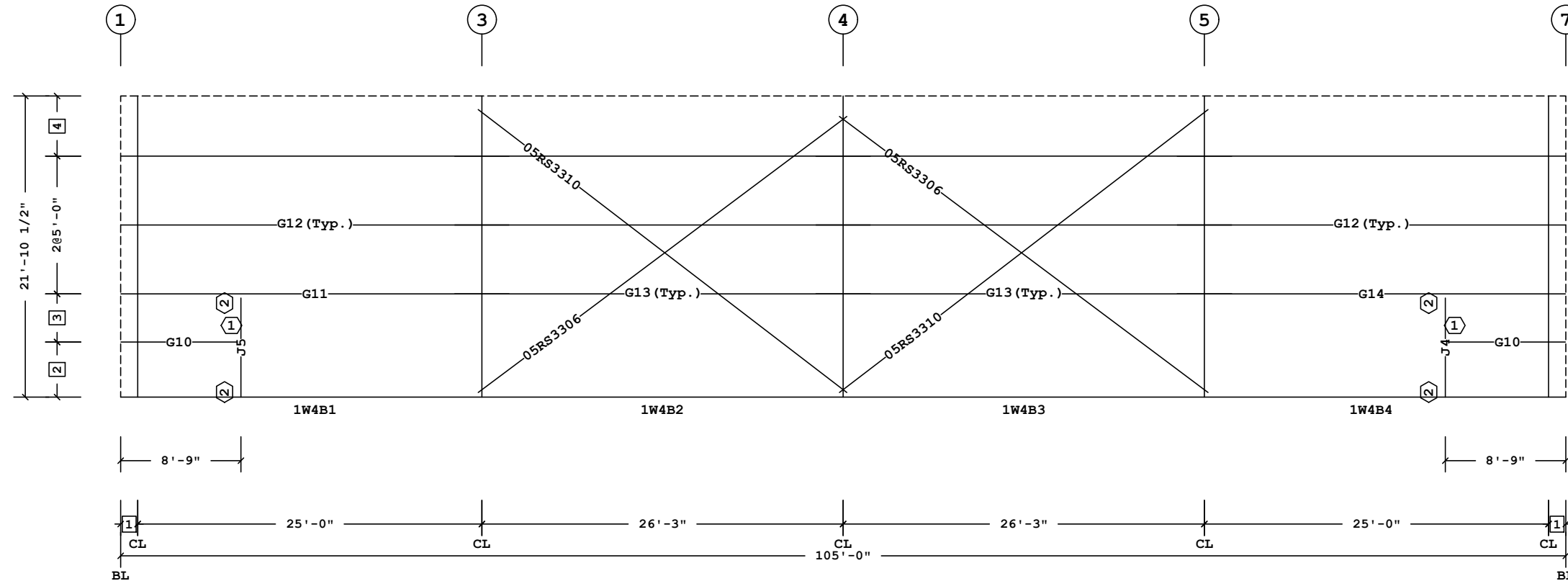

SECONDARY ELEVATION AT E

Bracing Part Schedule

Part	Qty	Length	Detail
05RS3306	2	33'-6"	BR01G2
05RS3310	2	33'-10"	BR01G2

4	4'-4 1/2"	3	0543333
3	3'-6"	2	PG1
2	4'-0"	1	JTG4
1	1'-3"		

Dimension Key Part Mark Key

Shape Name = 110' x 150' Shop Expansion, Wall = 4

- UNLESS NOTED, USE 1/2 X 1 1/2 A325T BOLT (49080) AND NUT (47120) W/O WASHERS. SNUG TIGHTEN BOLTS FOR ALL SECONDARY CONNECTIONS.
- FLANGE BRACES ARE AN INTEGRAL PART OF THE STABILITY OF THE STRUCTURAL SYSTEM AND MUST BE PROPERLY INSTALLED PRIOR TO ERECTION OF WALL AND ROOF SHEETS.
- REMOVAL OR ALTERATION OF ANY COMPONENT IS PROHIBITED.

THE BUTLER MFG. ENGINEER'S SEAL APPLIES ONLY TO THE WORK PRODUCT OF BUTLER MFG. AND DESIGN AND PERFORMANCE REQUIREMENTS SPECIFIED BY BUTLER. THE BUTLER MFG. ENGINEER'S SEAL DOES NOT APPLY TO THE PERFORMANCE OR DESIGN OF ANY OTHER PRODUCT OR COMPONENT FURNISHED BY BUTLER EXCEPT TO ANY DESIGN OR PERFORMANCE REQUIREMENTS SPECIFIED BY BUTLER.

THIS DRAWING, INCLUDING THE INFORMATION HEREON, REMAINS THE PROPERTY OF BUTLER MFG. IT IS PROVIDED SOLELY FOR ERECTING THE BUILDING DESCRIBED IN THE APPLICABLE PURCHASE ORDER AND MAY BE REPRODUCED ONLY FOR THAT PURPOSE. IT SHALL NOT BE MODIFIED, REPRODUCED OR USED FOR ANY OTHER PURPOSE WITHOUT PRIOR WRITTEN APPROVAL OF BUTLER MFG.

THE GENERAL CONTRACTOR AND/OR ERECTOR IS SOLELY RESPONSIBLE FOR ACCURATE GOOD QUALITY WORKMANSHIP IN ERECTING THIS BUILDING IN ACCORDANCE WITH THIS DRAWING, DETAILS REFERENCED IN THIS DRAWING, ALL APPLICABLE BUTLER MFG. ERECTION GUIDES, AND INDUSTRY STANDARDS PERTAINING TO PROPER ERECTION, INCLUDING THE CORRECT USE OF TEMPORARY BRACING.

REV		DATE	BY	DESCRIPTION	BUILDER	CUSTOMER	LOCATION	PROJECT	BUILDER'S PO#
				BUTLER MANUFACTURING 1540 GENESSEE ST. KANSAS CITY, MO 64102	Salacia Construction		Slidell, Louisiana	RV Storage - Legacy Buick GMC - Slidell	
				NTS					



JOB #	DATE	DRAWN/CHECK	PAGE
	4/5/2024	/	

Covering Schedule

Id	Qty	Start Length	Qty	Stagger Length	Type	Gage	OP
#15	26	37'-7 1/4"	26	32'-7 1/4"	MR24	24	13
#16	26	20'-9 1/2"	26	25'-9 1/2"	MR24	24	11
#17	1	20'-6"			MR24	24	86
#18	1	27'-7 1/4"			MR24	24	86
#19	1	10'-9 1/2"			MR24	24	87
#20	1	27'-7 1/4"			MR24	24	86
#21	1	20'-6"			MR24	24	86
#22	1	10'-9 1/2"			MR24	24	87
#23	26	20'-9 1/2"	26	25'-9 1/2"	MR24	24	11
#24	26	37'-7 1/4"	26	32'-7 1/4"	MR24	24	13

Oper. Code:13=SQ, NT
 Oper. Code:11=SQ, SQ
 Oper. Code:86=SQ, NT
 Oper. Code:87=SQ, SQ
 Finish:Z=AlZn
 Color:AZ=Plain AlZn

Insulation Schedule (Install in same direction as Covering)

Id	Qty	Type	Start Run	Last Run	Thick.	Facin g
BLK1	1	IB	61'-0"		9.25	AV
BLK2	17	IB	61'-0"	61'-0"	9.25	AV
BLK3	1	IB	59'-0"		9.25	AV
BLK4	17	IB	59'-0"	59'-0"	9.25	AV

Starter Width= 3'-0", Interm. Width= 6'-0", End Width= 6'-0"

Location =Outside Secondary Structural
 Direction =Across Secondary Structural
 Type:IB=Fiberglass Blanket
 Facing:AV=VR-R

Accessory Schedule

Qty	Color	Description
6	White	3070 Door - Standard
6	Cool Shell Gray	Shadowall 3070 Walk Door Trim

Trim Schedule

Id	Parts	Color	Details
T1	0630043	Cool Birch White	
T2	(10.5)IRT10C, (5.3)RC20	Match Roof Color	ENB004, NV667
T3	0560173, MRRET, RBT2, TC1, (0.5)WA10A	Cool Birch White	
T4	0630043	Cool Birch White	

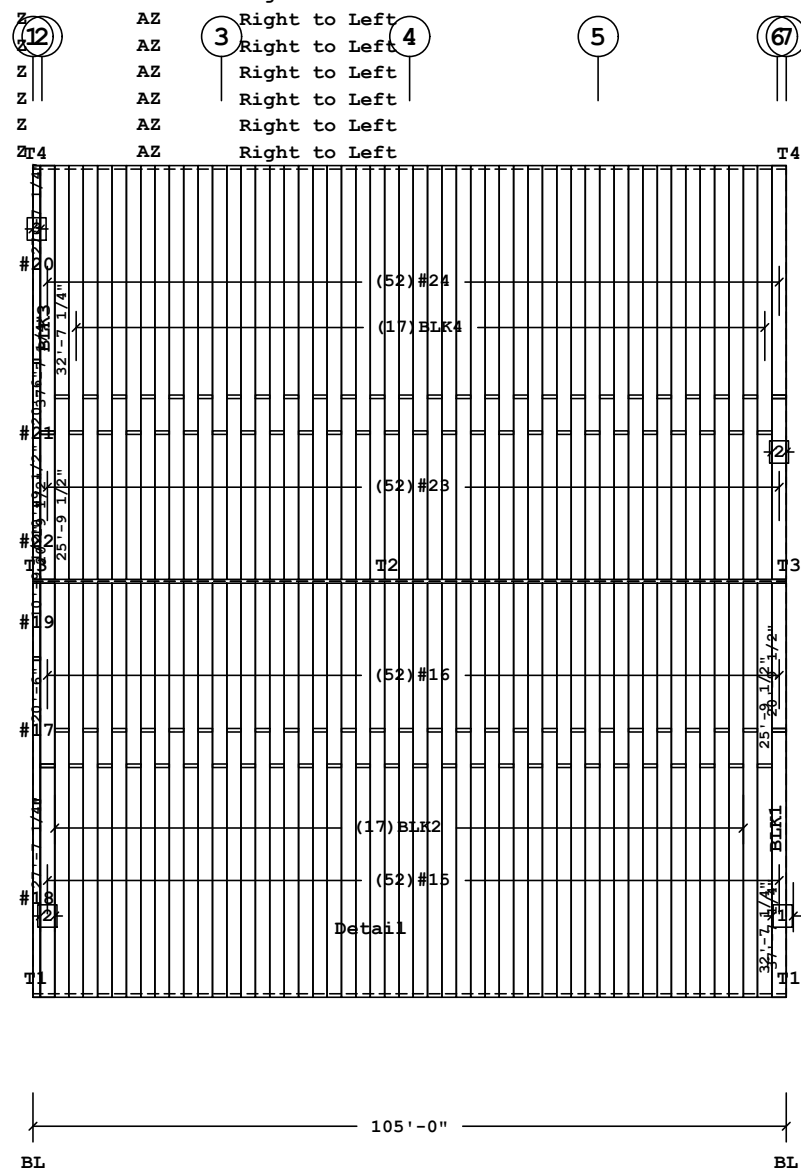

ROOF COVERING PLAN

Planograph Schedule

Id	Details
T1	P-080572, P-081236, P-103223, P-104542, P-104714
T2	P-080573, P-080575, P-080578, P-080949, P-ZRSLO
T3	P-081167, P-081243, P-GAI
T4	P-080572, P-081236, P-103223, P-104542, P-104714

Shape Name = 110' x 150' Shop Expansion

- PRE-DRILLING 1/8 DIAMETER HOLES FOR STRUCTURAL FASTENERS MAY BE REQUIRED FOR HEAVY GAGE NESTED ZEE'S AND/OR FASTENERS TO STRUCTURAL BEAMS
- STEEL PANELS ARE AN INTEGRAL PART OF THE STRUCTURAL SYSTEM. REMOVAL OR ALTERATION WITHOUT PRIOR AUTHORIZATION IS PROHIBITED.
- DUE TO MANUFACTURING LIMITATIONS SHORT PANELS MAY REQUIRE FIELD CUTTING. SEE THE COVERING SCHEDULE FOR CUT LENGTHS.
- SEE JOB DETAILS FOR COVERING AND TRIM FASTENER SPECIFICATION.

THE BUTLER MFG. ENGINEER'S SEAL APPLIES ONLY TO THE WORK PRODUCT OF BUTLER MFG. AND DESIGN AND PERFORMANCE REQUIREMENTS SPECIFIED BY BUTLER. THE BUTLER MFG. ENGINEER'S SEAL DOES NOT APPLY TO THE PERFORMANCE OR DESIGN OF ANY OTHER PRODUCT OR COMPONENT FURNISHED BY BUTLER EXCEPT TO ANY DESIGN OR PERFORMANCE REQUIREMENTS SPECIFIED BY BUTLER.

THIS DRAWING, INCLUDING THE INFORMATION HEREON, REMAINS THE PROPERTY OF BUTLER MFG. IT IS PROVIDED SOLELY FOR ERECTING THE BUILDING DESCRIBED IN THE APPLICABLE PURCHASE ORDER AND MAY BE REPRODUCED ONLY FOR THAT PURPOSE. IT SHALL NOT BE MODIFIED, REPRODUCED OR USED FOR ANY OTHER PURPOSE WITHOUT PRIOR WRITTEN APPROVAL OF BUTLER MFG.

THE GENERAL CONTRACTOR AND/OR ERECTOR IS SOLELY RESPONSIBLE FOR ACCURATE GOOD QUALITY WORKMANSHIP IN ERECTING THIS BUILDING IN ACCORDANCE WITH THIS DRAWING, DETAILS REFERENCED IN THIS DRAWING, ALL APPLICABLE BUTLER MFG. ERECTION GUIDES, AND INDUSTRY STANDARDS PERTAINING TO PROPER ERECTION, INCLUDING THE CORRECT USE OF TEMPORARY BRACING.

B	BUTLER MANUFACTURING		ROOF COVERING PLAN	
	1540 GENESSEE ST. KANSAS CITY, MO 64102			
REV	DATE	BY	DESCRIPTION	BUILDER: Salacia Construction
				CUSTOMER:
				LOCATION: Slidell, Louisiana
				PROJECT: RV Storage - Legacy Buick GMC - Slidell
				BUILDER'S PO#:
DRAWING SCALE: NTS				Butler Manufacturing VPC VERSION: ADVNXT 6.8
				JOB #: DATE: 4/5/2024 DRAWING CHECK: / PAGE:

Covering Schedule

Id	Qty	Type	Start Length	Gage	OP	Fin.	Color	Increment	Direction
#1	1	SHP	22'-0 1/4"	26	1	K	SY		Left to Right
#2	8	SHP	8'-2 3/8"	26	2	K	SY	3"	Left to Right
#3	1	SHP	24'-2 5/8"	26	1	K	SY		Left to Right
#4	8	SHP	10'-5 3/8"	26	2	K	SY	3"	Left to Right
#5	1	SHP	26'-6 1/4"	26	1	K	SY		Left to Right
#6	20	SHP	26'-7 1/4"	26	1	K	SY	-3"	Left to Right

Oper. Code:1=SQ, SQ

Oper. Code:2=SQ, SQ

Finish:K=Butler-Cote

Color:SY=Cool Shell Gray

Insulation Schedule (Install in same direction as Covering)

Id	Qty	Type	Start Run	Last Run	Thick.	Facing	Increment
BLK1	1	IB	23'-6"		6.00	AV	
BLK2	3	IB	10'-0"	11'-0"	6.00	AV	6"
BLK3	2	IB	25'-6"	26'-0"	6.00	AV	6"
BLK4	3	IB	12'-6"	13'-6"	6.00	AV	6"
BLK5	1	IB	28'-0"		6.00	AV	
BLK6	10	IB	28'-0"	23'-6"	6.00	AV	6"

Starter Width= 4'-0", Intern. Width= 6'-0", End Width= 6'-0"

Location =Outside Secondary Structural

Direction =Across Secondary Structural

Type:IB=Fiberglass Blanket

Facing:AV=VR-R

Shape Name = 110' x 150' Shop Expansion, Wall

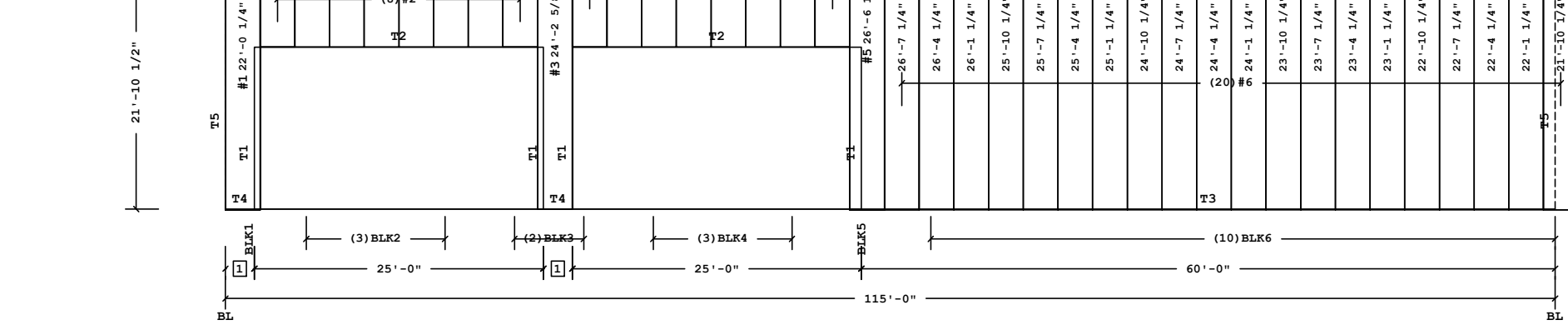

1 2'-6"
Dimension Key

COVERING ELEVATION AT 1

Fastener Schedule

Part	Description
0097362-112	Scrubolt 11/32 x 1 1/2", T-45 Torx Hd w/Washer
0097364-112	(T-1) 1/4-14 x 3/4", T-30 Torx Hd w/Washer

Flanograph Schedule

Id	Details
T1	P-081201, P-081202, P-081203
T2	P-081202
T3	P-081180, P-081505
T4	P-081180, P-081505
T5	P-081180, P-081185
T6	P-081167, P-081183, P-GAI
T7	P-081167, P-081183, P-GAI

Trim Schedule

Id	Parts
T1	(1.5)DSF12C
T2	DFP14, DFP12, (2.5)DGS12
T3	(2.4)BA225, (5)BT12A
T4	(0.1)BA225, (0.5)BT12A
T5	(3.5)0620163, (2)SHOCT12
T6	(3)MRGT20R, (5)SHCL12, (6)WA10A
T7	(3)MRGT20L, (5)SHCL12, (6)WA10A

Color
Match Wall Color
Match Wall Color
Match Wall Color
Match Wall Color
Match Wall Color
Cool Birch White
Cool Birch White

Details

NV568, NV569, WCB024, WCB025
WCB144
ENB006, GV386, GV442, NV115, NV120
ENB006, GV386, GV442, NV115, NV120
NV118, NV119, NV133, NV134
KV403, KV404, PV167
KV403, KV404, PV167

1. PRE-DRILLING 1/8 DIAMETER HOLES FOR STRUCTURAL FASTENERS MAY BE REQUIRED FOR HEAVY GAGE NESTED ZEE'S AND/OR FASTENERS TO STRUCTURAL BEAMS
 2. STEEL PANELS ARE AN INTEGRAL PART OF THE STRUCTURAL SYSTEM. REMOVAL OR ALTERATION WITHOUT PRIOR AUTHORIZATION IS PROHIBITED.
 3. DUE TO MANUFACTURING LIMITATIONS SHORT PANELS MAY REQUIRE FIELD CUTTING, SEE THE COVERING SCHEDULE FOR CUT LENGTHS.
 4. SEE JOB DETAILS FOR COVERING AND TRIM FASTENER SPECIFICATION.

THE BUTLER MFG. ENGINEER'S SEAL APPLIES ONLY TO THE WORK PRODUCT OF BUTLER MFG. AND DESIGN AND PERFORMANCE REQUIREMENTS SPECIFIED BY BUTLER. THE BUTLER MFG. ENGINEER'S SEAL DOES NOT APPLY TO THE PERFORMANCE OR DESIGN OF ANY OTHER PRODUCT OR COMPONENT FURNISHED BY BUTLER EXCEPT TO ANY DESIGN OR PERFORMANCE REQUIREMENTS SPECIFIED BY BUTLER.

THIS DRAWING, INCLUDING THE INFORMATION HEREON, REMAINS THE PROPERTY OF BUTLER MFG. IT IS PROVIDED SOLELY FOR ERECTING THE BUILDING DESCRIBED IN THE APPLICABLE PURCHASE ORDER AND MAY BE REPRODUCED ONLY FOR THAT PURPOSE. IT SHALL NOT BE MODIFIED, REPRODUCED OR USED FOR ANY OTHER PURPOSE WITHOUT PRIOR WRITTEN APPROVAL OF BUTLER MFG.
 THE GENERAL CONTRACTOR AND/OR ERECTOR IS SOLELY RESPONSIBLE FOR ACCURATE GOOD QUALITY WORKMANSHIP IN ERECTING THIS BUILDING IN ACCORDANCE WITH THIS DRAWING, DETAILS REFERENCED IN THIS DRAWING, ALL APPLICABLE BUTLER MFG. ERECTION GUIDES, AND INDUSTRY STANDARDS PERTAINING TO PROPER ERECTION, INCLUDING THE CORRECT USE OF TEMPORARY BRACING.

B		BUTLER MANUFACTURING 1540 GENESSEE ST. KANSAS CITY, MO 64102		110' x 150' Shop Expansion-Covering at 1	
REV	DATE	BY	DESCRIPTION	BUILDER: Salacia Construction	CUSTOMER:
				LOCATION: Slidell, Louisiana	PROJECT: RV Storage - Legacy Buck GMC - Slidell
DRAWING SCALE: NTS				BUILDER'S POK:	BUTLER Butler Manufacturing VFC VERSION: ADVNXT 6.8
JOB #:				DATE: 4/5/2024	DRAWN/CHECK: /
PAGE:				PAGE:	

Covering Schedule

Id	Qty	Type	Start Length	Gage	OP	Fin.	Color	Direction
#7	35	SHP	22'-0 1/4"	26	1	K	SY	Left to Right

Oper. Code:1=SQ, SQ
 Finish:K=Butler-Cote
 Color:SY=Cool Shell Gray

Trim Schedule

Id	Parts
T1	(4.2)BA225, (9)BT12A
T2	CTB2L, CTB2R
T3	(3.5)0620163, (2)SHOCT12
T4	(9)CLE12C, (9)SHCL12, (4.5)WGTR25
T5	5CE75, CB, (2.5)CP510

Color
Match Wall Color
Cool Birch White
Match Wall Color
Cool Birch White
Cool Birch White

Details

ENB006, GV386, GV442, NV115, NV120	NV128, NV130, NV135, NV143, NV664, WCB082, WCB083, WCB085, WCB086, WSR065
ENB006, NV664	
NV118, NV119, NV133, NV134	
EN60B1, EN60C1, EN60D1, MV274, NV110, NV116, NV131	
KV854	

Insulation Schedule (Install in same direction as Covering)

Id	Qty	Type	Start Run	Last Run	Thick.	Facing	Increment
BLK1	1	IB	23'-0"		6.00	AV	
BLK2	17	IB	23'-0"	23'-0"	6.00	AV	

Starter Width= 4'-0", Intern. Width= 6'-0", End Width= 6'-0"
 Location =Outside Secondary Structural
 Direction =Across Secondary Structural
 Type:IB=Fiberglass Blanket
 Facing:AV=VR-R

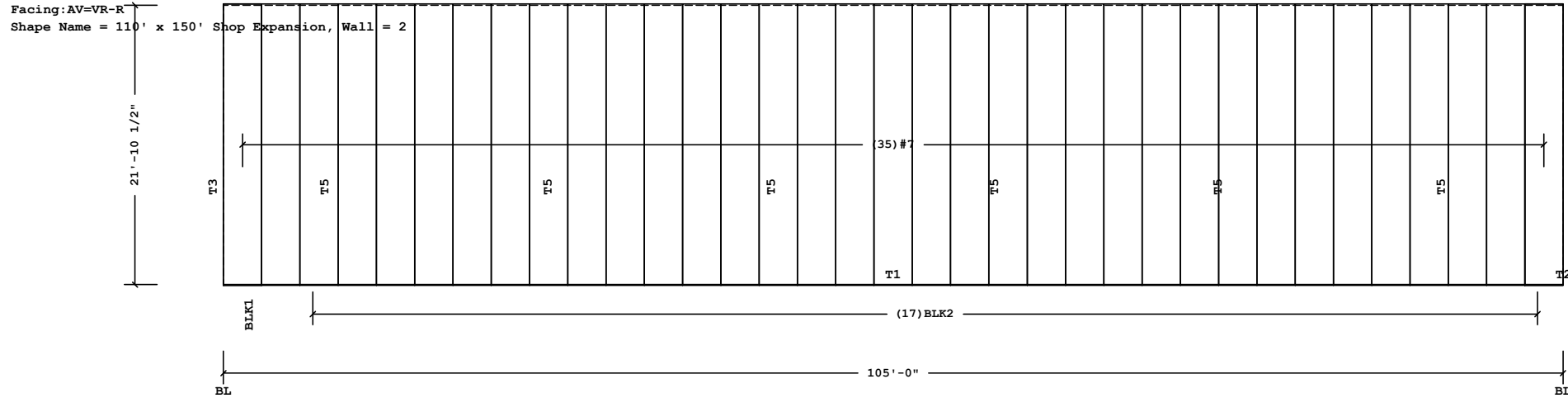

COVERING ELEVATION AT A

Fastener Schedule

Part	Description
0097362-112	Scrubolt 11/32 x 1 1/2", T-45 Torx Hd w/Washer
0097364-112	(T-1) 1/4-14 x 3/4", T-30 Torx Hd w/Washer

Planograph Schedule

Id	Details
T1	P-081180, P-081505
T2	P-081180, P-081505
T3	P-081180, P-081185
T4	P-080082, P-080089, P-081241, P-105017
T5	P-080091, P-081240, P-105228

Shape Name = 110' x 150' Shop Expansion, Wall = 2

1. PRE-DRILLING 1/8 DIAMETER HOLES FOR STRUCTURAL FASTENERS MAY BE REQUIRED FOR HEAVY GAGE NESTED ZEE'S AND/OR FASTENERS TO STRUCTURAL BEAMS
 2. STEEL PANELS ARE AN INTEGRAL PART OF THE STRUCTURAL SYSTEM. REMOVAL OR ALTERATION WITHOUT PRIOR AUTHORIZATION IS PROHIBITED.
 3. DUE TO MANUFACTURING LIMITATIONS SHORT PANELS MAY REQUIRE FIELD CUTTING. SEE THE COVERING SCHEDULE FOR CUT LENGTHS.
 4. SEE JOB DETAILS FOR COVERING AND TRIM FASTENER SPECIFICATION.

THE BUTLER MFG. ENGINEER'S SEAL APPLIES ONLY TO THE WORK PRODUCT OF BUTLER MFG. AND DESIGN AND PERFORMANCE REQUIREMENTS SPECIFIED BY BUTLER. THE BUTLER MFG. ENGINEER'S SEAL DOES NOT APPLY TO THE PERFORMANCE OR DESIGN OF ANY OTHER PRODUCT OR COMPONENT FURNISHED BY BUTLER EXCEPT TO ANY DESIGN OR PERFORMANCE REQUIREMENTS SPECIFIED BY BUTLER.

THIS DRAWING, INCLUDING THE INFORMATION HEREON, REMAINS THE PROPERTY OF BUTLER MFG. IT IS PROVIDED SOLELY FOR ERECTING THE BUILDING DESCRIBED IN THE APPLICABLE PURCHASE ORDER AND MAY BE REPRODUCED ONLY FOR THAT PURPOSE. IT SHALL NOT BE MODIFIED, REPRODUCED OR USED FOR ANY OTHER PURPOSE WITHOUT PRIOR WRITTEN APPROVAL OF BUTLER MFG.
 THE GENERAL CONTRACTOR AND/OR ERECTOR IS SOLELY RESPONSIBLE FOR ACCURATE GOOD QUALITY WORKMANSHIP IN ERECTING THIS BUILDING IN ACCORDANCE WITH THIS DRAWING. DETAILS REFERENCED IN THIS DRAWING, ALL APPLICABLE BUTLER MFG. ERECTION GUIDES, AND INDUSTRY STANDARDS PERTAINING TO PROPER ERECTION, INCLUDING THE CORRECT USE OF TEMPORARY BRACING.

REV	DATE	BY	DESCRIPTION
B			

BUTLER MANUFACTURING
 1540 GENESSEE ST. KANSAS CITY, MO 64102

110' x 150' Shop Expansion-Covering at A	
BUILDER: Salacia Construction	CUSTOMER:
LOCATION: Slidell, Louisiana	PROJECT: RV Storage - Legacy Buick GMC - Slidell
BUILDER'S P.O.#:	BUTLER
	Butler Manufacturing
	VFC VERSION: ADVNXT 6.8

Covering Schedule

Id	Qty	Type	Start Length	Gage	OP	Fin.	Color	Increment	Direction
#8	19	SHP	22'-0 1/4"	26	1	K	SY	3"	Left to Right
#9	1	SHP	26'-7 1/4"	26	1	K	SY		Left to Right
#10	8	SHP	12'-3 3/8"	26	2	K	SY	-3"	Left to Right
#11	2	SHP	24'-4 1/4"	26	1	K	SY	-3"	Left to Right
#12	7	SHP	9'-9 3/8"	26	2	K	SY	-3"	Left to Right
#13	2	SHP	22'-1 1/4"	26	1	K	SY	-3"	Left to Right

Oper. Code:1=SQ, SQ

Oper. Code:2=SQ, SQ

Finish:K=Butler-Cote

Color:SY=Cool Shell Gray

Insulation Schedule (Install in same direction as Covering)

Id	Qty	Type	Start Run	Last Run	Thick.	Facing	Increment
BLK1	1	IB	23'-6"		6.00	AV	
BLK2	8	IB	24'-0"	27'-6"	6.00	AV	6"
BLK3	1	IB	28'-0"		6.00	AV	
BLK4	6	IB	28'-0"	25'-6"	6.00	AV	6"
BLK5	3	IB	11'-0"	10'-0"	6.00	AV	6"
BLK6	1	IB	23'-6"		6.00	AV	

Starter Width= 4'-0", Intern. Width= 6'-0", End Width= 6'-0"

Location =Outside Secondary Structural

Direction =Across Secondary Structural

Type:IB=Fiberglass Blanket

Facing:AV=VR-R

Shape Name = 110' x 150' Shop Expansion, Wall = 3

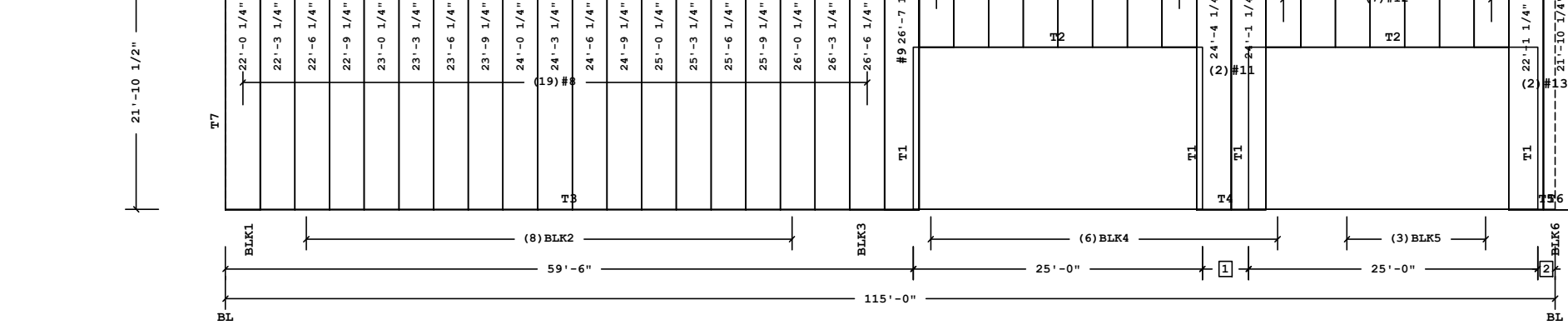

- 2 1'-6"
- 1 4'-0"
- Dimension Key

COVERING ELEVATION AT 7

Fastener Schedule

Part	Description
0097362-112	Scrubolt 11/32 x 1 1/2", T-45 Torx Hd w/Washer
0097364-112	(T-1) 1/4-14 x 3/4", T-30 Torx Hd w/Washer

Planograph Schedule

Id	Details
T1	P-081201, P-081202, P-081203
T2	P-081202
T3	P-081180, P-081505
T4	P-081180, P-081505
T5	P-081180, P-081505
T6	P-081180, P-081505
T7	P-081180, P-081185
T8	P-081167, P-081183, P-GAI
T9	P-081167, P-081183, P-GAI

1. PRE-DRILLING 1/8 DIAMETER HOLES FOR STRUCTURAL FASTENERS MAY BE REQUIRED FOR HEAVY GAGE NESTED ZEE'S AND/OR FASTENERS TO STRUCTURAL BEAMS
 2. STEEL PANELS ARE AN INTEGRAL PART OF THE STRUCTURAL SYSTEM. REMOVAL OR ALTERATION WITHOUT PRIOR AUTHORIZATION IS PROHIBITED.
 3. DUE TO MANUFACTURING LIMITATIONS SHORT PANELS MAY REQUIRE FIELD CUTTING. SEE THE COVERING SCHEDULE FOR CUT LENGTHS.
 4. SEE JOB DETAILS FOR COVERING AND TRIM FASTENER SPECIFICATION.

THE BUTLER MFG. ENGINEER'S SEAL APPLIES ONLY TO THE WORK PRODUCT OF BUTLER MFG. AND DESIGN AND PERFORMANCE REQUIREMENTS SPECIFIED BY BUTLER. THE BUTLER MFG. ENGINEER'S SEAL DOES NOT APPLY TO THE PERFORMANCE OR DESIGN OF ANY OTHER PRODUCT OR COMPONENT FURNISHED BY BUTLER EXCEPT TO ANY DESIGN OR PERFORMANCE REQUIREMENTS SPECIFIED BY BUTLER.

THIS DRAWING, INCLUDING THE INFORMATION HEREON, REMAINS THE PROPERTY OF BUTLER MFG. IT IS PROVIDED SOLELY FOR ERECTING THE BUILDING DESCRIBED IN THE APPLICABLE PURCHASE ORDER AND MAY BE REPRODUCED ONLY FOR THAT PURPOSE. IT SHALL NOT BE MODIFIED, REPRODUCED OR USED FOR ANY OTHER PURPOSE WITHOUT PRIOR WRITTEN APPROVAL OF BUTLER MFG.
 THE GENERAL CONTRACTOR AND/OR ERECTOR IS SOLELY RESPONSIBLE FOR ACCURATE GOOD QUALITY WORKMANSHIP IN ERECTING THIS BUILDING IN ACCORDANCE WITH THIS DRAWING. DETAILS REFERENCED IN THIS DRAWING, ALL APPLICABLE BUTLER MFG. ERECTION GUIDES, AND INDUSTRY STANDARDS PERTAINING TO PROPER ERECTION, INCLUDING THE CORRECT USE OF TEMPORARY BRACING.

B BUTLER MANUFACTURING
 1540 GENESSEE ST. KANSAS CITY, MO 64102

REV	DATE	BY	DESCRIPTION

110' x 150' Shop Expansion-Covering at 7

BUILDER: Salacia Construction	CUSTOMER:
LOCATION: Slidell, Louisiana	DATE: 4/5/2024
PROJECT: RV Storage - Legacy Buick GMC - Slidell	DRAWN/CHECKED: /
BUILDER'S P.O.#:	PAGE: /

VPIC VERSION: ADVNXT 6.8
 a division of BlueScope Buildings North America, Inc.

Covering Schedule

Id	Qty	Type	Start Length	Gage	OP	Fin.	Color	Direction
#14	35	SHP	22'-0 1/4"	26	1	K	SY	Left to Right

Oper. Code:1=SQ, SQ
Finish:K=Butler-Cote
Color:SY=Cool Shell Gray

Trim Schedule

Id	Parts
T1	(4.2)BA225, (9)BT12A
T2	CTB2L, CTB2R
T3	(9)CLE12C, (9)SHCL12, (4.5)WGTR25
T4	5CE75, CB, (2.5)CP510

Color
Match Wall Color
Cool Birch White
Cool Birch White
Cool Birch White

Details

ENB006, GV386, GV442, NV115, NV120	NV128, NV130, NV135, NV143, NV664, WCB082, WCB083, WCB085, WCB086, WSR065
ENB006, NV664	
EN60B1, EN60C1, EN60D1, MV274, NV110, NV116, NV131	
KV854	

Insulation Schedule (Install in same direction as Covering)

Id	Qty	Type	Start Run	Last Run	Thick.	Facing	Increment
BLK1	1	IB	23'-0"		6.00	AV	
BLK2	17	IB	23'-0"	23'-0"	6.00	AV	

Starter Width= 4'-0", Inter. Width= 6'-0", End Width= 6'-0"

Location =Outside Secondary Structural

Direction =Across Secondary Structural

Type:IB=Fiberglass Blanket

Facing:AV=VR-R

Shape Name = 110' x 150' Shop Expansion, Wall = 4

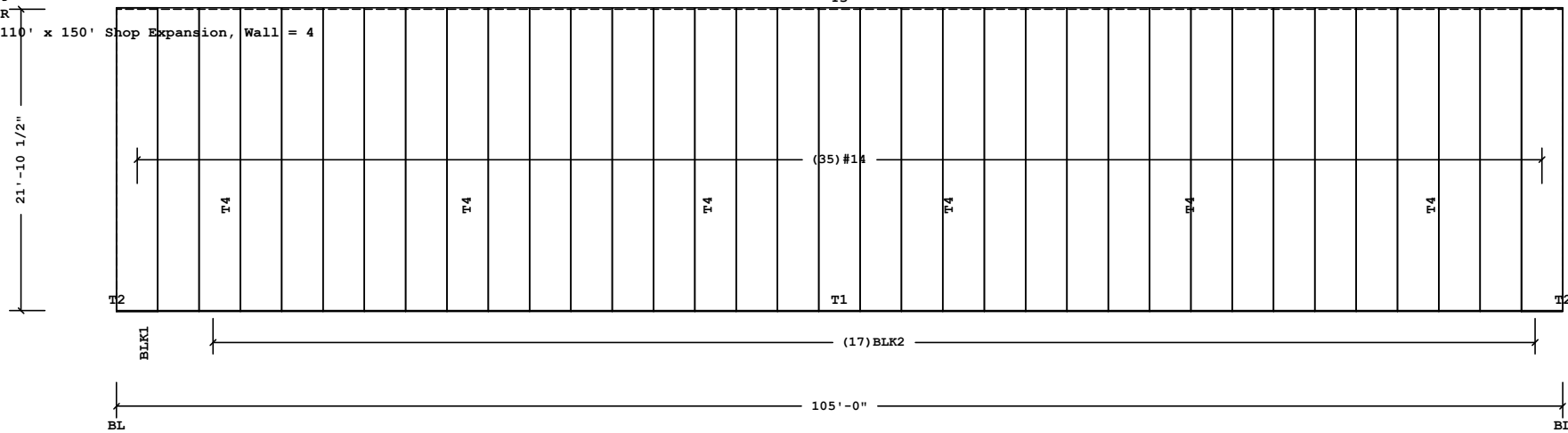

COVERING ELEVATION AT E

Fastener Schedule

Part	Description
0097362-112	Scrubolt 11/32 x 1 1/2", T-45 Torx Hd w/Washer
0097364-112	(T-1) 1/4-14 x 3/4", T-30 Torx Hd w/Washer

Planograph Schedule

Id	Details
T1	P-081180, P-081505
T2	P-081180, P-081505
T3	P-080082, P-080089, P-081241, P-105017
T4	P-080091, P-081240, P-105228

Shape Name = 110' x 150' Shop Expansion, Wall = 4

1. PRE-DRILLING 1/8 DIAMETER HOLES FOR STRUCTURAL FASTENERS MAY BE REQUIRED FOR HEAVY GAGE NESTED ZEE'S AND/OR FASTENERS TO STRUCTURAL BEAMS
2. STEEL PANELS ARE AN INTEGRAL PART OF THE STRUCTURAL SYSTEM. REMOVAL OR ALTERATION WITHOUT PRIOR AUTHORIZATION IS PROHIBITED.
3. DUE TO MANUFACTURING LIMITATIONS SHORT PANELS MAY REQUIRE FIELD CUTTING. SEE THE COVERING SCHEDULE FOR CUT LENGTHS.
4. SEE JOB DETAILS FOR COVERING AND TRIM FASTENER SPECIFICATION.

THE BUTLER MFG. ENGINEER'S SEAL APPLIES ONLY TO THE WORK PRODUCT OF BUTLER MFG. AND DESIGN AND PERFORMANCE REQUIREMENTS SPECIFIED BY BUTLER. THE BUTLER MFG. ENGINEER'S SEAL DOES NOT APPLY TO THE PERFORMANCE OR DESIGN OF ANY OTHER PRODUCT OR COMPONENT FURNISHED BY BUTLER EXCEPT TO ANY DESIGN OR PERFORMANCE REQUIREMENTS SPECIFIED BY BUTLER.

THIS DRAWING, INCLUDING THE INFORMATION HEREON, REMAINS THE PROPERTY OF BUTLER MFG. IT IS PROVIDED SOLELY FOR ERECTING THE BUILDING DESCRIBED IN THE APPLICABLE PURCHASE ORDER AND MAY BE REPRODUCED ONLY FOR THAT PURPOSE. IT SHALL NOT BE MODIFIED, REPRODUCED OR USED FOR ANY OTHER PURPOSE WITHOUT PRIOR WRITTEN APPROVAL OF BUTLER MFG.
THE GENERAL CONTRACTOR AND/OR ERECTOR IS SOLELY RESPONSIBLE FOR ACCURATE GOOD QUALITY WORKMANSHIP IN ERECTING THIS BUILDING IN ACCORDANCE WITH THIS DRAWING. DETAILS REFERENCED IN THIS DRAWING, ALL APPLICABLE BUTLER MFG. ERECTION GUIDES, AND INDUSTRY STANDARDS PERTAINING TO PROPER ERECTION, INCLUDING THE CORRECT USE OF TEMPORARY BRACING.

B BUTLER MANUFACTURING 1540 GENESSEE ST. KANSAS CITY, MO 64102			
REV	DATE	BY	DESCRIPTION

110' x 150' Shop Expansion-Covering at E	
BUILDER: Salacia Construction	CUSTOMER:
LOCATION: Slidell, Louisiana	PROJECT: RV Storage - Legacy Buick GMC - Slidell
BUILDER'S POK:	BUTLER Butler Manufacturing VFC VERSION: ADVNXT 6.8