

SINGLE WALL

SH95P Maximum 10" w.g. Positive Static						
Nominal Oval Size	Galv Spiral Duct Ga	Galv Fitting Ga	Spiral Duct Wt. (lb/ft)	Spiral Duct Std. Lgth (ft)	Equiv Round	
4 x 10	24	20	2.7	6	6.60	
12	24	20	3.1	6	7.19	
13	24	20	3.4	6	7.46	
15	24	20	3.8	6	7.96	
16	24	20	4.2	6	8.19	
18	24	20	4.5	6	8.63	
20	24	20	4.9	6	9.03	
5 x 11	24	20	3.1	6	7.75	
13	24	20	3.4	6	8.41	
14	24	20	3.8	6	8.71	
16	24	20	4.2	6	9.26	
18	24	20	4.5	6	9.77	
19	24	20	4.9	6	10.01	
21	24	20	5.2	6	10.46	
6 x 10	24	20	3.1	6	8.07	
12	24	20	3.4	6	8.87	
14	24	20	3.8	6	9.58	
16	24	20	4.2	6	10.21	
17	24	20	4.5	6	10.51	
19	24	20	4.9	6	11.06	
20	24	20	5.2	12	11.33	
22	24	20	5.6	12	11.82	
23	24	20	5.9	12	12.06	
25	22	20	7.6	12	12.51	
26	22	20	8.0	12	12.73	
28	22	20	8.5	12	13.15	
29	22	20	8.9	12	13.35	
31	22	20	9.3	12	13.73	
34	22	20	10.2	12	14.28	
37	22	18	11.0	12	14.80	
41	22	18	11.8	12	15.45	
44	22	18	12.7	12	15.90	
47	22	18	13.5	12	16.34	
50	20	18	17.0	12	16.76	
53	20	18	17.9	12	17.16	
56	20	18	18.9	12	17.55	
59	20	18	19.9	12	17.92	
63	20	16	20.9	12	18.40	
66	20	16	21.9	12	18.75	
69	20	16	22.9	12	19.08	
72	18	16	31.2	12	19.42	
75	18	16	32.5	12	19.73	
79	18	16	33.8	12	20.14	
82	18	16	35.1	12	20.43	
85	18	16	36.4	12	20.73	
88	18	16	37.7	12	21.01	
91	18	16	39.0	12	21.29	
7 x 10	24	20	3.1	6	8.66	
12	24	20	3.4	6	9.56	
13	24	20	3.8	6	9.97	
15	24	20	4.2	6	10.72	
17	24	20	4.5	6	11.39	
18	24	20	4.9	6	11.71	
20	24	20	5.2	6	12.30	
8 x 11	24	20	3.4	6	9.69	
12	24	20	3.8	6	10.17	
14	24	20	4.2	6	11.04	
16	24	20	4.5	6	11.86	

SH95P Maximum 10" w.g. Positive Static						
Nominal Oval Size	Galv Spiral Duct Ga	Galv Fitting Ga	Spiral Duct Wt. (lb/ft)	Spiral Duct Std. Lgth (ft)	Equiv Round	
8 x 17	24	20	4.9	6	12.20	
19	24	20	5.2	12	12.88	
21	24	20	5.6	12	13.52	
22	24	20	5.9	12	13.82	
24	24	20	6.3	12	14.39	
25	22	20	8.0	12	14.66	
27	22	20	8.5	12	15.19	
28	22	20	8.9	12	15.44	
30	22	20	9.3	12	15.92	
33	22	20	10.2	12	16.61	
36	22	20	11.0	12	17.25	
39	22	18	11.8	12	17.86	
43	22	18	12.7	12	18.62	
46	22	18	13.5	12	19.16	
49	20	18	17.0	12	19.68	
52	20	18	17.9	12	20.17	
55	20	18	18.9	12	20.65	
58	20	18	19.9	12	21.11	
61	20	16	20.9	12	21.55	
65	20	16	21.9	12	22.12	
68	20	16	22.9	12	22.53	
71	18	16	31.2	12	22.93	
74	18	16	32.5	12	23.31	
77	18	16	33.8	12	23.69	
81	18	16	35.1	12	24.18	
84	18	16	36.4	12	24.53	
87	18	16	37.7	12	24.88	
90	18	16	39.0	12	25.22	
10 x 16	24	20	4.9	12	13.16	
18	24	20	5.2	12	14.01	
19	24	20	5.6	12	14.41	
21	24	20	5.9	12	15.15	
23	24	20	6.3	12	15.85	
24	24	20	6.6	12	16.18	
26	22	20	8.5	12	18.82	
27	22	20	8.9	12	17.12	
29	22	20	9.3	12	17.71	
32	22	20	10.2	12	18.53	
35	22	20	11.0	12	19.30	
38	22	18	11.8	12	20.02	
41	22	18	12.7	12	20.71	
45	22	18	13.5	12	21.57	
48	22	18	14.4	12	22.18	
51	20	18	17.9	12	22.76	
54	20	18	18.9	12	23.32	
57	20	18	19.9	12	23.86	
60	20	18	20.9	12	24.39	
63	20	16	21.9	12	24.89	
67	20	16	22.9	12	25.54	
70	20	16	23.9	12	26.00	
73	18	16	32.5	12	26.46	
76	18	16	33.8	12	26.90	
79	18	16	35.1	12	27.33	
83	18	16	36.4	12	27.89	
86	18	16	37.7	12	28.29	
89	18	16	39.0	12	28.69	
92	18	16	40.3	12	29.08	
12 x 17	24	20	5.2	12	14.78	

SH95P Maximum 10" w.g. Positive Static					
Nominal Oval Size	Galv Spiral Duct Ga	Galv Fitting Ga	Spiral Duct Wt. (lb/ft)	Spiral Duct Std. Lgth (ft)	Equiv Round
12 x 18	24	20	5.6	12	15.25
20	24	20	5.9	12	16.15
21	24	20	6.3	12	16.57
23	24	20	6.6	12	17.37
25	22	20	8.5	12	18.11
26	22	20	8.9	12	18.47
28	22	20	9.3	12	19.16
31	22	20	10.2	12	20.12
34	22	20	11.0	12	21.02
37	22	18	11.8	12	21.86
40	22	18	12.7	12	22.65
43	22	18	13.5	12	23.40
47	22	18	14.4	12	24.35
50	20	18	17.9	12	25.03
53	20	18	18.9	12	25.67
56	20	18	19.9	12	26.29
59	20	18	20.9	12	26.89
62	20	16	21.9	12	27.47
65	20	16	22.9	12	28.03
69	20	16	23.9	12	28.74
72	18	16	32.5	12	29.26
75	18	16	33.8	12	29.77
78	18	16	35.1	12	30.26
81	18	16	36.4	12	30.74
85	18	16	37.7	12	31.36
88	18	16	39.0	12	31.81
91	18	16	40.3	12	32.25
14 x 17	24	20	5.6	12	15.78
19	24	20	5.9	12	16.83
20	24	20	6.3	12	17.32
22	24	20	6.6	12	18.25
23	24	20	7.0	12	18.69
25	22	20	8.9	12	19.53
27	22	20	9.3	12	20.32
30	22	20	10.2	12	21.43
33	22	20	11.0	12	22.46
36	22	20	11.8	12	23.42
39	22	18	12.7	12	24.33
42	22	18	13.5	12	25.18
45	22	18	14.4	12	25.99
49	20	18	17.9	12	27.02
52	20	18	18.9	12	27.75
55	20	18	19.9	12	28.45
58	20	18	20.9	12	29.12
61	20	16	21.9	12	29.77
64	20	16	22.9	12	30.40
67	20	16	23.9	12	31.01
71	18	16	32.5	12	31.79
74	18	16	33.8	12	32.36
77	18	16	35.1	12	32.91
80	18	16	36.4	12	33.45
83	18	16	37.7	12	33.97
87	18	16	39.0	12	34.65
90	18	16	40.3	12	35.14
16 x 18	24	20	5.9	12	17.23
19	24	20	6.3	12	17.80
20	24	20	6.6	12	18.35
22	24	20	7.0	12	19.38

SH95P Maximum 10" w.g. Positive Static					
Nominal Oval Size	Galv Spiral Duct Ga	Galv Fitting Ga	Spiral Duct Wt. (lb/ft)	Spiral Duct Std. Lgth (ft)	Equiv Round
16 x 24	24	20	7.3	12	20.34
25	22	20	9.2	12	20.80
29	22	20	10.2	12	22.50
32	22	20	11.0	12	23.60
35	22	20	11.8	12	24.74
38	22	18	12.7	12	25.76
41	22	18	13.5	12	26.72
44	22	18	14.4	12	27.63
47	22	18	15.2	12	28.50
51	20	18	18.9	12	29.59
54	20	18	19.9	12	30.37
57	20	18	20.9	12	31.12
60	20	18	21.9	12	31.85
63	20	16	22.9	12	32.55
66	20	16	23.9	12	33.22
69	20	16	24.9	12	33.87
73	18	16	33.8	12	34.72
76	18	16	35.1	12	35.33
79	18	16	36.4	12	35.92
82	18	16	37.7	12	36.50
85	18	16	39.0	12	37.06
89	18	16	40.3	12	37.79
18 x 20	24	20	6.6	12	19.24
21	24	20	7.0	12	19.82
22	24	20	7.3	12	20.37
24	24	20	7.6	12	21.42
27	22	20	10.2	12	22.88
31	22	20	11.0	12	24.64
34	22	20	11.8	12	25.85
37	22	18	12.7	12	26.99
40	22	18	13.5	12	28.05
43	22	18	14.4	12	29.06
46	22	18	15.2	12	30.02
49	20	18	18.9	12	30.94
53	20	18	19.9	12	32.10
56	20	18	20.9	12	32.92
59	20	18	21.9	12	33.72
62	20	16	22.9	12	34.49
65	20	16	23.9	12	35.23
68	20	16	24.9	12	35.95
72	18	16	33.8	12	36.87
75	18	16	35.1	12	37.54
78	18	16	36.4	12	38.19
81	18	16	37.7	12	38.82
84	18	16	39.0	12	39.44
87	18	16	40.3	12	40.04
20 x 26	22	20	10.2	12	23.46
29	22	20	11.0	12	24.95
33	22	20	11.8	12	26.77
36	22	20	12.7	12	28.02
39	22	18	13.5	12	29.20
42	22	18	14.4	12	30.31
45	22	18	15.2	12	31.36
48	22	18	16.1	12	32.37
51	20	18	19.9	12	33.32
55	20	18	20.9	12	34.54
58	20	18	21.9	12	35.41
61	20	16	22.9	12	36.25

SH95P Maximum 10" w.g. Positive Static					
Nominal Oval Size	Galv Spiral Duct Ga	Galv Fitting Ga	Spiral Duct Wt. (lb/ft)	Spiral Duct Std. Lgth (ft)	Equiv Round
20 x 64	20	16	23.9	12	37.06
67	20	16	24.9	12	37.84
71	18	16	33.8	12	38.84
74	18	16	35.1	12	39.57
77	18	16	36.4	12	40.28
80	18	16	37.7	12	40.97
83	18	16	39.0	12	41.64
86	18	16	40.3	12	42.29
22 x 25	22	20	10.2	12	23.84
28	22	20	11.0	8	35.49
31	22	20	11.8	8	27.01
35	22	20	12.7	8	28.87
38	22	18	13.5	8	30.16
41	22	18	14.4	8	31.38
44	22	18	15.2	8	32.53
47	22	18	16.1	8	33.63
50	20	18	19.9	8	34.67
53	20	18	20.9	8	35.67
57	20	18	21.9	8	36.94
60	20	18	22.9	8	37.85
63	20	16	23.9	8	38.72
66	20	16	24.9	8	39.57
69	20	16	25.9	8	40.39
73	18	16	35.1	8	41.44
76	18	16	36.4	8	42.21
79	18	16	37.7	12	42.95
82	18	16	39.0	12	43.67
85	18	16	40.3	12	44.38
24 x 27	22	20	11.0	12	25.85
30	22	20	11.8	8	27.52
33	22	20	12.7	8	29.07
37	22	18	13.5	8	30.97
40	22	18	14.4	8	32.29
43	22	18	15.2	8	33.54
46	22	18	16.1	8	34.71
49	20	18	19.9	8	35.86
52	20	18	20.9	8	36.94
55	20	18	21.9	8	37.94
59	20	18	22.9	8	39.29
63	20	16	23.9	8	40.24
65	20	16	24.9	8	41.15
68	20	16	25.9	8	42.03
71	18	16	35.1	8	42.89
75	18	16	36.4	8	43.99
78	18	16	37.7	12	44.78
81	18	16	39.0	12	45.56
84	18	16	40.3	12	46.32
26 x 32	22	20	12.7	8	29.55
35	22	20	13.5	8	31.11
38	22	18	14.4	8	32.54
42	22	18	15.2	8	34.40
45	22	18	16.1	8	35.69
48	22	18	19.9	8	36.91
51	20	18	20.9	8	38.07
54	20	18	21.9	8	39.18
57	20	18	22.9	8	40.25
60	20	18	23.9	8	41.28
64	20	16	24.9	8	42.59

SH95P Maximum 10" w.g. Positive Static					
Nominal Oval Size	Galv Spiral Duct Ga	Galv Fitting Ga	Spiral Duct Wt. (lb/ft)	Spiral Duct Std. Lgth (ft)	Equiv Round
26 x 67	18	16	33.8	12	43.54
70	18	16	35.1	12	44.46
73	18	16	36.4	12	45.34
77	18	16	37.7	12	46.48
80	18	16	39.0	12	47.31
83	18	16	40.3	12	48.12
28 x 31	22	20	12.7	12	29.87
35	22	20	13.5	12	32.11
37	22	18	14.4	8	33.15
40	22	18	15.2	8	34.64
44	22	18	16.1	8	36.50
47	22	18	16.9	8	37.82
50	20	18	20.9	8	39.07
53	20	18	21.9	8	40.26
56	20	18	22.9	8	41.40
59	20	18	23.9	8	42.50
62	20	16	24.9	8	43.56
66	20	16	25.9	8	44.92
69	18	16	35.1	12	45.90
72	18	16	36.4	12	46.84
75	18	16	37.7	12	47.76
79	18	16	39.0	12	48.94
82	18	16	40.3	12	49.80
30 x 33	22	20	13.5	12	31.87
37	22	18	14.4	12	34.13
39	22	18	15.2	8	35.19
42	22	18	16.1	8	36.70
46	22	18	16.9	8	38.59
49	20	18	20.9	8	39.93
52	20	18	21.9	8	41.21
55	20	18	22.9	8	42.43
58	20	18	23.9	8	43.60
61	20	16	24.9	8	44.73
64	20	16	25.9	8	45.82
68	20	16	26.9	8	47.22
71	18	16	36.4	12	48.22
74	18	16	37.7	12	49.20
77	18	16	39.0	12	50.14
81	18	16	40.3	12	41.36
32 x 39	22	18	15.2	12	36.15
41	22	18	16.1	8	37.22
44	22	18	16.9	8	38.76
48	22	18	17.8	8	40.68
51	20	18	21.9	8	42.04
54	20	18	22.9	8	43.34
57	20	18	23.9	8	44.59
60	20	18	24.9	8	45.79
63	20	16	25.9	8	46.94
66	20	16	26.9	8	48.06
70	20	16	27.9	8	49.49
73	18	16	37.7	12	50.52
76	18	16	39.0	12	51.52
79	18	16	40.3	12	52.50

DOUBLE WALL

SH95P Maximum 10" w.g. Positive Static					
Nominal Oval Size	Galv Spiral Duct Ga	Galv Fitting Ga	Spiral Duct Wt. (lb/ft)	Spiral Duct Std. Lgth (ft)	Equiv Round
4 x 10	24/26	20/24	5.37	6	6.60
12	24/26	20/24	5.95	6	7.19
15	24/26	20/24	7.19	6	7.96
18	24/26	20/24	8.42	6	8.63
20	24/26	20/24	9.00	6	9.03
5 x 11	24/26	20/24	5.95	6	7.75
13	24/26	20/24	6.61	6	8.41
16	24/26	20/24	7.76	6	9.26
18	24/26	20/24	8.42	6	9.77
6 x 10	24/26	20/24	5.95	6	8.07
12	24/26	20/24	6.61	6	8.87
14	24/26	20/24	7.27	6	9.58
17	24/26	20/24	8.42	6	10.51
19	24/26	20/24	9.00	6	11.06
20	24/26	20/24	9.57	12	11.33
22	24/26	20/24	10.15	12	11.82
23	22/26	20/24	12.15	12	12.06
25	22/26	20/24	12.88	12	12.51
26	22/26	20/24	13.53	12	12.73
28	22/26	20/24	14.18	12	13.15
31	22/26	20/24	15.56	12	13.73
34	22/26	20/24	16.86	12	14.28
37	22/24	18/22	19.26	12	14.80
41	22/24	18/22	20.68	12	15.45
44	22/24	18/22	22.10	12	15.90
47	20/24	18/22	26.07	12	16.34
50	20/24	18/22	27.64	12	16.76
53	20/24	18/22	29.22	12	17.16
56	20/24	18/22	30.79	12	17.55
59	20/22	16/22	34.82	12	17.92
63	20/22	16/22	37.43	12	18.40
66	20/22	16/22	39.21	12	18.75
69	18/22	16/22	48.13	12	19.08
72	18/22	16/22	50.21	12	19.41
75	18/22	16/22	52.25	10	19.73
79	18/22	16/22	54.28	10	20.14
82	18/22	16/22	56.27	10	20.43
85	18/22	16/22	58.35	10	20.73
88	18/22	16/22	60.35	10	21.01
8 x 14	24/26	20/24	7.76	6	11.04
16	24/26	20/24	8.42	6	11.83
17	24/26	20/24	9.00	6	12.20
19	24/26	20/24	9.57	12	12.88
21	24/26	20/24	10.15	12	13.52
22	24/26	20/24	10.72	12	13.82
24	22/26	20/24	12.88	12	14.39
25	22/26	20/24	13.53	12	14.66
27	22/26	20/24	14.18	12	15.19

SH95P Maximum 10" w.g. Positive Static					
Nominal Oval Size	Galv Spiral Duct Ga	Galv Fitting Ga	Spiral Duct Wt. (lb/ft)	Spiral Duct Std. Lgth (ft)	Equiv Round
8 x 30	22/26	20/24	15.56	12	15.92
33	22/26	20/24	16.86	12	16.61
36	22/26	18/22	18.24	12	17.25
39	22/24	18/22	20.68	12	17.86
43	22/24	18/22	22.10	12	18.62
46	22/24	18/22	23.52	12	19.16
49	20/24	18/22	27.64	12	19.68
52	20/24	18/22	29.22	12	20.17
55	20/24	18/22	30.79	12	20.65
58	20/24	18/22	32.36	12	21.11
61	20/22	16/22	37.43	12	21.55
65	20/22	16/22	39.21	12	22.12
68	20/22	16/22	40.90	12	22.53
71	18/22	16/22	50.21	12	22.93
74	18/22	16/22	52.20	12	23.31
77	18/22	16/22	54.28	10	23.69
81	18/22	16/22	56.27	10	24.18
84	18/22	16/22	58.35	10	24.53
87	18/22	16/22	60.35	10	24.88
90	18/22	16/22	62.42	10	25.22
10 x 16	24/26	20/24	9.00	12	13.16
18	24/26	20/24	9.57	12	14.01
19	24/26	20/24	10.15	12	14.41
21	24/26	20/24	10.72	12	15.15
23	22/26	20/24	12.88	12	15.85
24	22/26	20/24	13.53	12	16.18
26	22/26	20/24	14.18	12	16.82
29	22/26	20/24	15.56	12	17.71
32	22/26	20/24	16.86	12	18.53
35	22/26	18/24	18.24	12	19.30
38	22/24	18/22	20.68	12	20.02
41	22/24	18/22	22.10	12	20.71
45	22/24	18/22	23.52	12	21.57
48	20/24	18/22	27.64	12	22.18
51	20/24	18/22	29.22	12	22.76
54	20/24	18/22	30.79	12	23.32
57	20/24	18/22	32.36	12	23.86
60	20/22	16/22	36.52	12	24.39
63	20/22	16/22	38.21	12	24.89
67	20/22	16/22	40.90	12	25.54
70	18/22	16/22	50.21	12	26.00
73	18/22	16/22	52.20	12	26.46
76	18/22	16/22	54.24	10	26.90
79	18/22	16/22	56.27	10	27.33
83	18/22	16/22	58.35	10	27.89
86	18/22	16/22	60.35	10	28.29
89	18/22	16/22	62.43	10	28.69
12 x 17	24/26	20/24	9.57	12	14.78

SH95P Maximum 10" w.g. Positive Static					
Nominal Oval Size	Galv Spiral Duct Ga	Galv Fitting Ga	Spiral Duct Wt. (lb/ft)	Spiral Duct Std. Lgth (ft)	Equip Round
12 x 18	24/26	20/24	10.15	12	15.25
20	24/26	20/24	10.72	12	16.15
21	24/26	20/24	12.88	12	16.57
23	22/26	20/24	13.53	12	17.37
25	22/26	20/24	14.18	12	18.11
28	22/26	20/24	15.56	12	19.16
31	22/26	20/24	16.86	12	20.12
34	22/26	20/24	18.24	12	21.02
37	22/24	18/22	20.67	12	21.86
40	22/24	18/22	22.10	12	22.65
43	22/24	18/22	23.52	12	23.40
47	20/24	18/22	27.64	12	24.35
50	20/24	18/22	29.22	12	25.03
53	20/24	18/22	30.79	12	25.67
56	20/24	18/22	32.36	12	26.29
59	20/22	16/22	36.52	12	26.89
62	20/22	16/22	39.21	12	27.47
65	20/22	16/22	40.90	12	28.03
69	18/22	16/22	50.21	12	28.74
72	18/22	16/22	52.20	12	29.26
75	18/22	16/22	54.24	12	29.77
78	18/22	16/22	56.27	10	30.26
81	18/22	16/22	58.35	10	30.74
85	18/22	16/22	60.35	10	31.36
88	18/22	16/22	62.43	10	31.81
14 x 17	24/26	20/24	10.15	12	15.78
20	24/26	20/24	11.38	12	17.32
22	22/26	20/24	11.95	12	18.25
23	22/26	20/24	14.18	12	18.69
27	22/26	20/24	15.56	12	20.32
30	22/26	20/24	16.86	12	21.43
33	22/26	20/24	18.24	12	22.46
36	22/26	18/22	19.53	12	23.42
39	22/24	18/22	22.10	12	24.33
42	22/24	18/22	23.52	12	25.18
45	22/24	18/22	24.94	12	25.99
49	20/24	18/22	29.21	12	27.02
52	20/24	18/22	30.79	12	27.75
55	20/24	18/22	32.36	12	28.45
58	20/24	18/22	33.93	12	29.12
61	20/22	16/22	39.21	12	29.77
64	20/22	16/22	40.90	12	30.40
67	20/22	16/22	42.68	12	31.01
71	18/22	16/22	50.20	12	31.79
74	18/22	16/22	54.28	12	32.36
77	18/22	16/22	56.32	10	32.91
80	18/22	16/22	58.35	10	33.45
83	18/22	16/22	60.35	10	33.97

SH95P Maximum 10" w.g. Positive Static					
Nominal Oval Size	Galv Spiral Duct Ga	Galv Fitting Ga	Spiral Duct Wt. (lb/ft)	Spiral Duct Std. Lgth (ft)	Equip Round
14 x 87	18/22	16/22	62.43	10	34.65
16 x 18	24/26	20/24	10.72	12	17.23
19	24/26	20/24	11.38	12	17.80
20	24/26	20/24	11.95	12	18.35
22	24/26	20/24	12.52	12	19.38
25	22/26	20/24	15.56	12	20.80
29	22/26	20/24	16.86	12	22.50
32	22/26	20/24	18.24	12	23.66
35	22/26	18/24	19.53	12	24.74
38	22/24	18/22	22.10	12	25.76
41	22/24	18/22	23.52	12	26.72
44	22/24	18/22	24.94	12	27.63
47	20/24	18/22	29.21	12	28.50
51	20/24	18/22	30.79	12	29.59
54	20/24	18/22	32.36	12	30.37
57	20/24	18/22	33.93	12	31.12
60	20/22	16/22	38.21	12	31.85
63	20/22	16/22	40.90	12	32.55
66	20/22	16/22	42.68	12	33.22
73	18/22	16/22	54.28	12	34.72
76	18/22	16/22	56.32	10	35.33
79	18/22	16/22	58.35	10	35.92
82	18/22	16/22	60.35	10	36.50
85	18/22	16/22	62.43	10	37.06
18 x 24	22/26	20/24	15.56	12	21.42
27	22/26	20/24	16.86	12	22.88
31	22/26	20/24	18.24	12	24.64
34	22/26	20/24	19.53	12	25.85
37	22/24	18/22	22.18	12	26.99
40	22/24	18/22	23.52	12	28.05
43	22/24	18/22	24.94	12	29.06
46	22/24	18/22	26.36	12	30.02
49	20/24	18/22	30.79	12	30.94
53	20/24	18/22	32.39	12	32.10
56	20/24	18/22	33.93	12	32.92
59	20/22	16/22	38.21	12	33.72
62	20/22	16/22	40.90	12	34.49
65	20/22	16/22	42.68	12	35.23
72	18/22	16/22	54.28	12	36.87
75	18/22	16/22	56.32	10	37.54
78	18/22	16/22	58.35	10	38.19
81	18/22	16/22	60.35	10	38.82
84	18/22	16/22	62.43	10	39.44
20 x 26	22/26	20/24	16.84	8	23.46
29	22/26	20/24	18.24	8	24.95
33	22/26	20/24	19.53	8	26.77
36	22/26	18/22	22.10	8	28.02
39	22/24	18/22	23.52	8	29.20

SH95P Maximum 10" w.g. Positive Static					
Nominal Oval Size	Galv Spiral Duct Ga	Galv Fitting Ga	Spiral Duct Wt. (lb/ft)	Spiral Duct Std. Lgth (ft)	Equiv Round
20 x 42	22/24	18/22	24.91	8	30.31
45	22/24	18/22	26.36	8	31.36
48	22/24	18/22	30.79	8	32.37
51	22/24	18/22	32.36	8	33.32
55	22/24	18/22	33.93	8	34.54
58	22/24	18/22	35.50	8	35.41
61	22/22	16/22	40.90	8	36.25
64	20/22	16/22	42.68	8	37.06
67	20/22	16/22	44.37	8	37.84
71	18/22	16/22	54.28	8	38.84
74	18/22	16/22	56.32	8	38.57
77	18/22	16/22	58.35	10	40.28
80	18/22	16/22	60.35	10	40.97
83	18/22	16/22	62.43	10	41.64
22 x 25	22/26	20/24	14.90	12	23.84
28	22/26	20/24	18.24	8	25.49
31	22/26	20/24	19.53	8	27.01
35	22/26	18/24	20.91	8	28.87
38	22/24	18/22	23.52	8	30.16
41	22/24	18/22	24.91	8	31.38
44	22/24	18/22	26.36	8	32.53
47	20/24	18/22	30.79	8	33.63
50	20/24	18/22	32.36	8	34.67
53	20/24	18/22	33.93	8	35.67
57	20/24	18/22	35.50	8	36.94
60	20/22	16/22	37.06	8	37.85
63	20/22	16/22	42.68	8	38.72
66	20/22	16/22	44.37	8	39.57
69	18/22	16/22	54.28	8	40.39
73	18/22	16/22	56.27	8	41.44
76	18/22	16/22	58.31	10	42.21
79	18/22	16/22	60.35	10	42.95
82	18/22	16/22	62.42	10	43.67
24 x 33	22/26	20/24	20.90	8	29.07
40	22/24	18/22	24.90	8	32.29
43	22/24	18/22	26.40	8	33.54
46	22/24	18/22	27.80	8	34.73
49	20/24	18/22	32.40	8	35.86
52	20/24	18/22	33.90	8	36.94
55	20/24	18/22	35.50	8	37.98
62	20/22	16/22	42.70	8	40.24
65	20/22	16/22	47.10	12	41.15
68	18/22	16/22	54.24	12	42.03
71	18/22	16/22	56.32	12	42.89
75	18/22	16/22	58.31	10	43.99
78	18/22	16/22	60.35	10	44.78
81	18/22	16/22	62.43	10	45.56

SH95P Maximum 10" w.g. Positive Static					
Nominal Oval Size	Galv Spiral Duct Ga	Galv Fitting Ga	Spiral Duct Wt. (lb/ft)	Spiral Duct Std. Lgth (ft)	Equiv Round
26 x 35	22/26	18/24	22.22	8	31.11
38	22/24	18/22	24.94	8	32.58
42	22/24	18/22	36.35	8	34.40
45	22/24	18/22	27.77	8	35.69
48	20/24	18/22	32.36	8	36.91
51	20/24	18/22	33.93	8	38.07
54	20/24	18/22	35.50	8	39.18
57	20/24	18/22	37.06	8	40.25
60	20/22	16/22	41.60	8	41.28
64	20/22	16/22	44.37	8	42.59
67	18/22	16/22	54.28	12	43.54
70	18/22	16/22	56.27	12	44.46
73	18/22	16/22	58.35	10	45.34
77	18/22	16/22	60.35	10	46.48
80	18/22	16/22	62.43	10	47.31
28 x 31	22/26	20/24	20.91	12	29.87
35	22/26	20/24	22.21	12	32.11
37	22/24	18/22	24.94	8	33.15
40	22/24	18/22	26.35	8	34.64
44	22/24	18/22	27.77	8	36.50
47	20/24	18/22	32.36	8	37.82
50	20/24	18/22	33.93	8	39.07
53	20/24	18/22	35.50	8	40.26
56	20/24	18/22	37.06	8	41.40
59	20/22	16/22	41.60	8	42.50
62	20/22	16/22	44.37	8	43.56
66	20/22	16/22	46.15	8	44.92
69	18/22	16/22	56.27	12	45.90
72	18/22	16/22	58.35	10	46.84
75	18/22	16/22	60.35	10	47.76
79	18/22	16/22	62.43	10	48.94
30 x 37	22/24	18/22	24.94	12	34.13
39	22/24	18/22	26.36	8	35.19
42	22/24	18/22	27.77	8	36.70
46	22/24	18/22	29.20	8	38.59
49	20/24	18/22	33.93	8	39.93
52	20/24	18/22	35.50	8	41.21
55	20/24	18/22	37.06	8	42.43
58	20/24	18/22	38.63	8	43.60
61	20/22	16/22	44.37	8	44.73
64	20/22	16/22	46.15	8	45.82
68	20/22	16/22	47.84	8	47.22
71	18/22	16/22	58.35	10	48.22
74	18/22	16/22	60.35	10	49.20
77	18/22	16/22	62.43	10	50.14

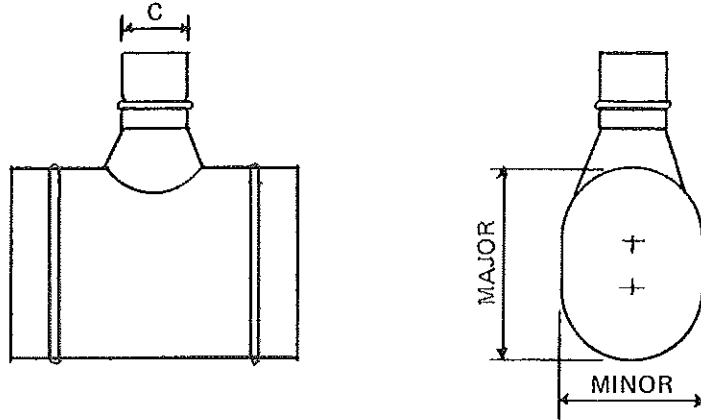

OT - 90
90° TEE

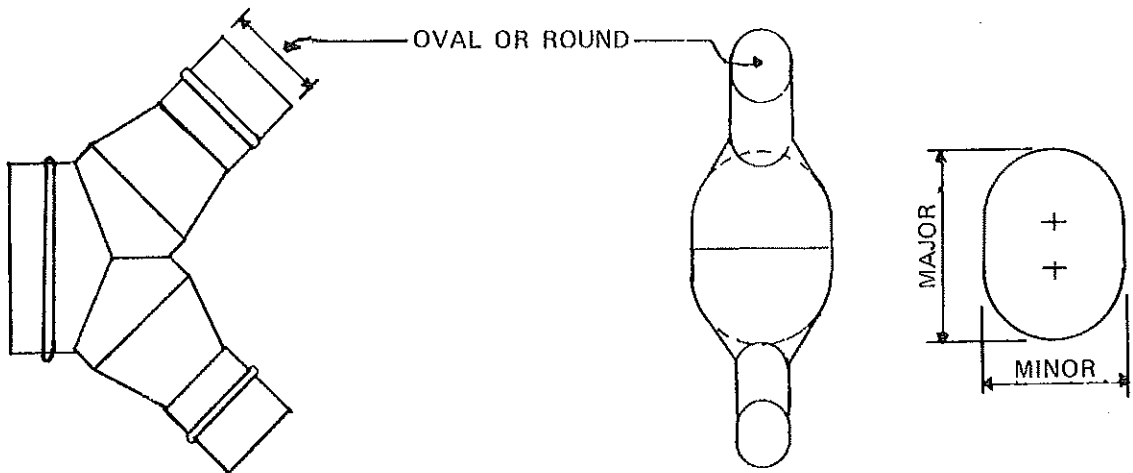

OY - 45
2-WAY 45° Y

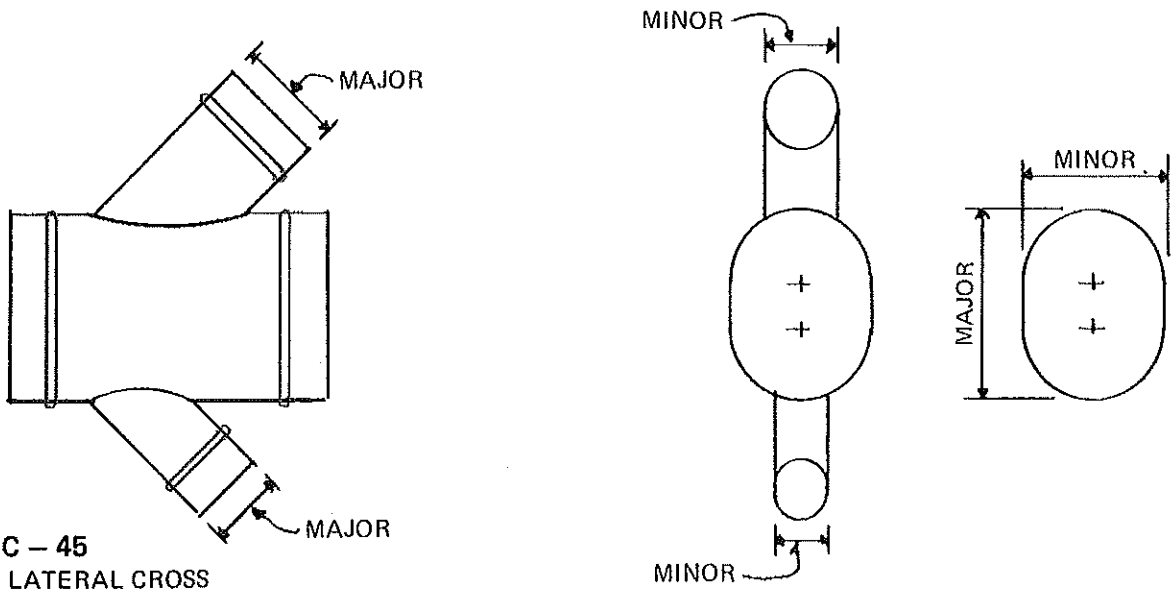

OLC - 45
45° LATERAL CROSS

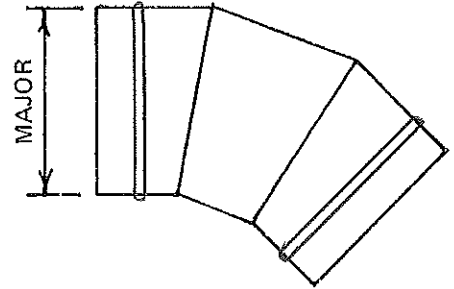
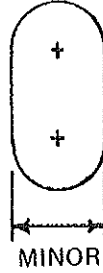
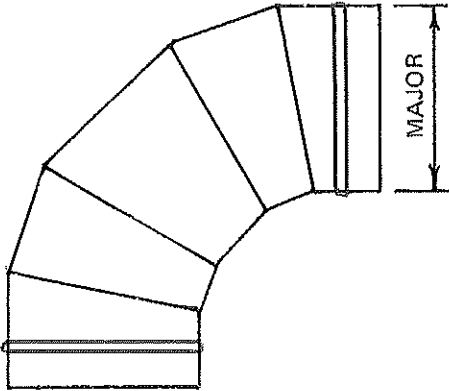

OEL5-90 HARD
 5 PIECE 90° ELBOW
 CENTER LINE RADIUS =
 1.5 X MAJOR DIMENSION

OEL3-45 HARD
 3 PIECE 45° ELBOW
 CENTER LINE RADIUS =
 1.5 X MAJOR DIMENSION

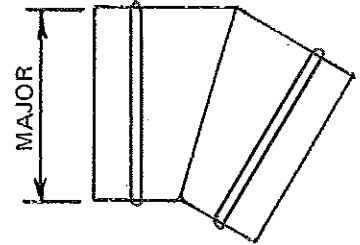
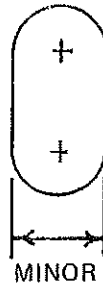
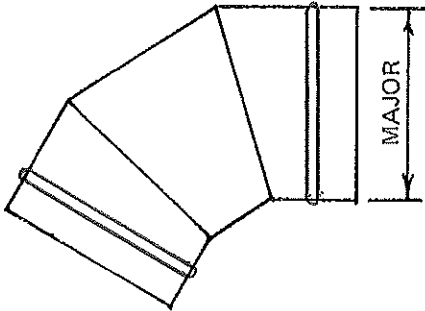

OEL3-60 HARD
 3 PIECE 60° ELBOW
 CENTER LINE RADIUS =
 1.5 X MAJOR DIMENSION

OEL2-30 HARD
 2 PIECE 90° ELBOW
 CENTER LINE RADIUS =
 1.5 X MAJOR DIMENSION

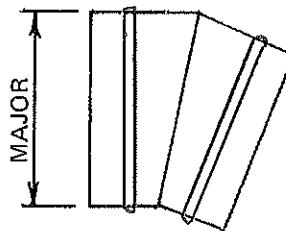

OEL2-22 HARD
 2 PIECE 22½° ELBOW
 CENTER LINE RADIUS =
 1.5 X MAJOR DIMENSION

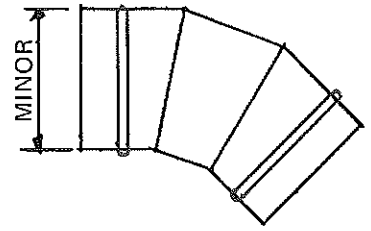
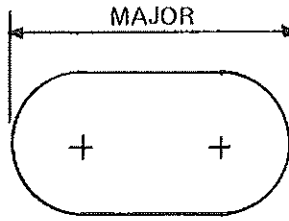
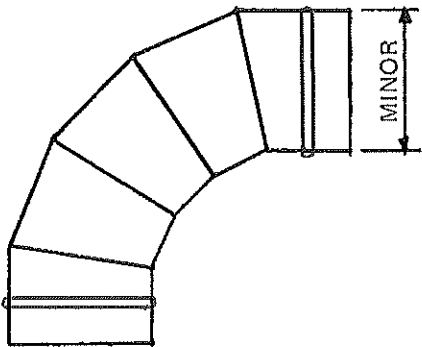

OEL5-90 EASY
 5-PIECE 90° ELBOW
 CENTER LINE RADIUS =
 1.5 X MINOR DIMENSION

OEL3-45 EASY
 3-PIECE 45° ELBOW
 CENTER LINE RADIUS =
 1.5 X MINOR DIMENSION

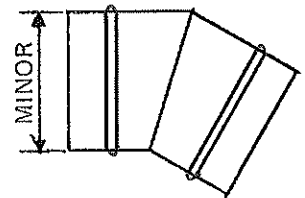
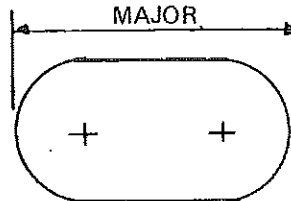
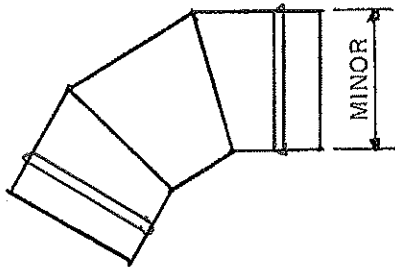

OEL3-60 EASY
 3-PIECE 60° ELBOW
 CENTER LINE RADIUS =
 1.5 X MINOR DIMENSION

OEL2-30 EASY
 2-PIECE 30° ELBOW
 CENTER LINE RADIUS =
 1.5 X MINOR DIMENSION

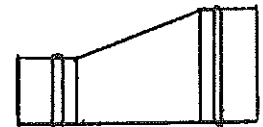
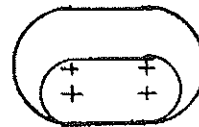
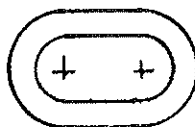
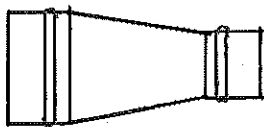

OCR - 1
 OVAL CONCENTRIC REDUCER

OER - 1
 OVAL ECCENTRIC REDUCER

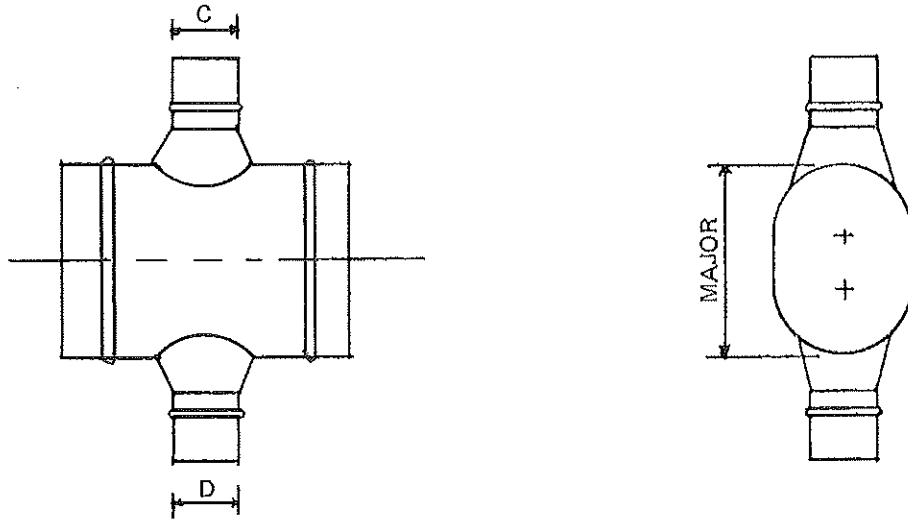

OC - 180
180° CROSS

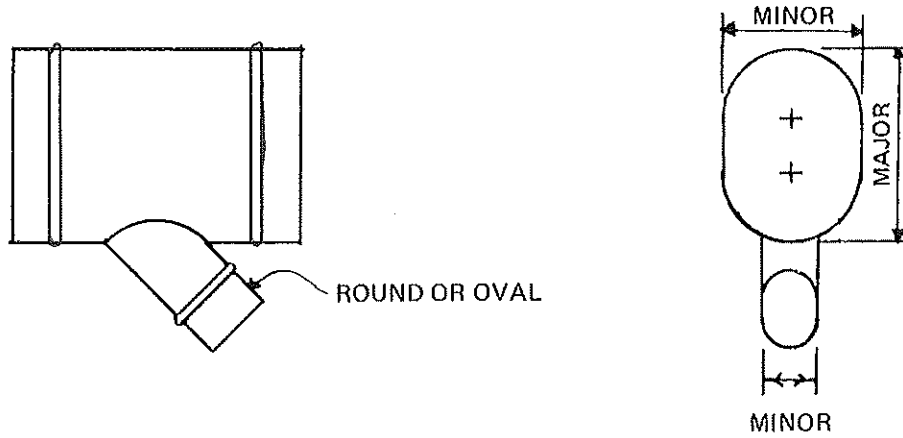

OL - 45°
45° LATERAL

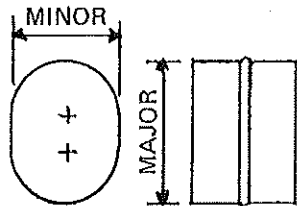

OPC - 1
OVAL PIPE COUPLING

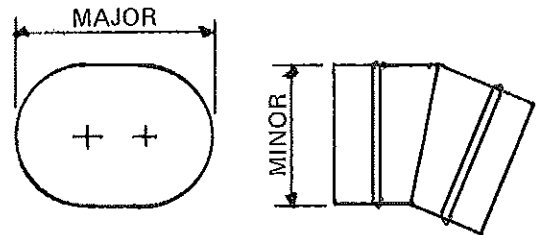

OEL2-22 EASY
2-PIECE 22½° ELBOW
CENTER LINE RADIUS =
1.5 X MINOR DIMENSION