

FOR QUESTIONS, CALL THE
Louisiana Office
REGION 27
PHONE: (985) 781 - 4107
EMAIL: reg27@captiveaire.com

PATENT NUMBERS
AC-PSP (UNITED STATES) - US PATENT 7963830 B2.
AC-PSP WALL (CANADA) - CA PATENT 2820509.
AC-PSP ISLAND (CANADA) - CA PATENT 2520330.

HOOD INFORMATION - JOB#2257876

HOOD NO	TAG	MODEL	MANUFACTURER	LENGTH	MAX COOKING TEMP	TYPE	APPLIANCE DUTY	DESIGN CFM/FT	TOTAL EXH CFM	EXHAUST PLENUM RISER(S)						TOTAL SUPPLY CFM	HOOD CONSTRUCTION	HOOD CONFIG		
										WIDTH	LENG	HEIGHT	DIA	CFM	VEL			SP	END TO END	ROW
1		5430 ND-2-PSP-F	CAPTIVEAIRE	9' 0"	450 DEG	I	MEDIUM	185	1665	10'	15'	4'		1665	1598	-0.585'	1498	430 SS WHERE EXPOSED	ALONE	ALONE

HOOD INFORMATION

HOOD NO	TAG	FILTER(S)				LIGHT(S)				UTILITY CABINET(S)				FIRE SYSTEM PIPING	HOOD HANGING WEIGHT			
		TYPE	QTY	HEIGHT	LENGTH	EFFICIENCY @ 7 MICRONS	QTY	TYPE	WIRE GUARD	LOCATION	SIZE	TYPE	SIZE			ELECTRICAL MODEL #	SWITCHES QUANTITY	
1		CAPRATE SOLD WITH HOOD	6	20"	16'	85% SEE FILTER SPEC	3	L55 SERIES E26	NO								NO	515 LBS

HOOD OPTIONS

HOOD NO	TAG	OPTION
1		BACKSPLASH 80.00" HIGH X 108.00" LONG 430 SS VERTICAL.

PERFORATED SUPPLY PLENUM(S)

HOOD NO	TAG	POS	LENGTH	WIDTH	HEIGHT	TYPE	RISER(S)				
							WIDTH	LENG	DIA	CFM	SP
1		Front	108"	14"	6"	MUA	12"	28"		749	0.181'
						MUA	12"	28"		749	0.181'

SPECIFICATION: CAPRATE® GREASE-STOP® SOLD FILTER

THE CAPRATE GREASE-STOP SOLD FILTER IS A SINGLE-STAGE FILTER FEATURING A UNIQUE S-BAFFLE DESIGN IN CONJUNCTION WITH A SLOTTED REAR BAFFLE DESIGN, TO DELIVER EXCEPTIONAL FILTRATION EFFICIENCY.

FILTER IS STAINLESS STEEL CONSTRUCTION, AND SIZED TO FIT INTO STANDARD 2-INCH DEEP HOOD CHANNEL(S).

UNITS SHALL INCLUDE STAINLESS STEEL HANDLES AND A FASTENING DEVICE TO SECURE THE TWO COMPONENTS WHEN ASSEMBLED.

GREASE EXTRACTION EFFICIENCY PERFORMANCE SHALL REMOVE AT LEAST 75% OF GREASE PARTICLES FIVE MICRONS IN SIZE, AND 85% GREASE PARTICLES SEVEN MICRONS IN SIZE AND LARGER, WITH A CORRESPONDING PRESSURE DROP NOT TO EXCEED 1.0 INCHES OF WATER GAUGE. THE CAPRATE GREASE-STOP SOLD WAS TESTED TO ASTM STANDARD ASTM F2519-05. MANUFACTURER APPROVED FOR USE IN SOLID FUEL APPLICATIONS AS A SPARK ARRESTER.

EFFICIENCY VS. PARTICLE DIAMETER

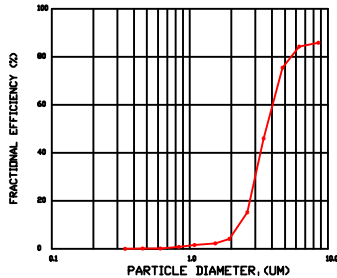

PRESSURE DROP VS. FLOW RATE

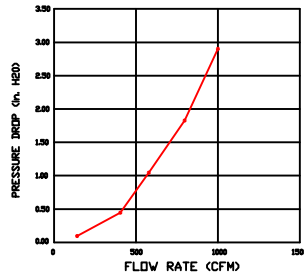

CAPRATE FILTERS ARE BUILT IN COMPLIANCE WITH:
NFPA #96.
NSF STANDARD #2.
UL STANDARD #1046.
INT. MECH. CODE (IMC).
ULC-S649.

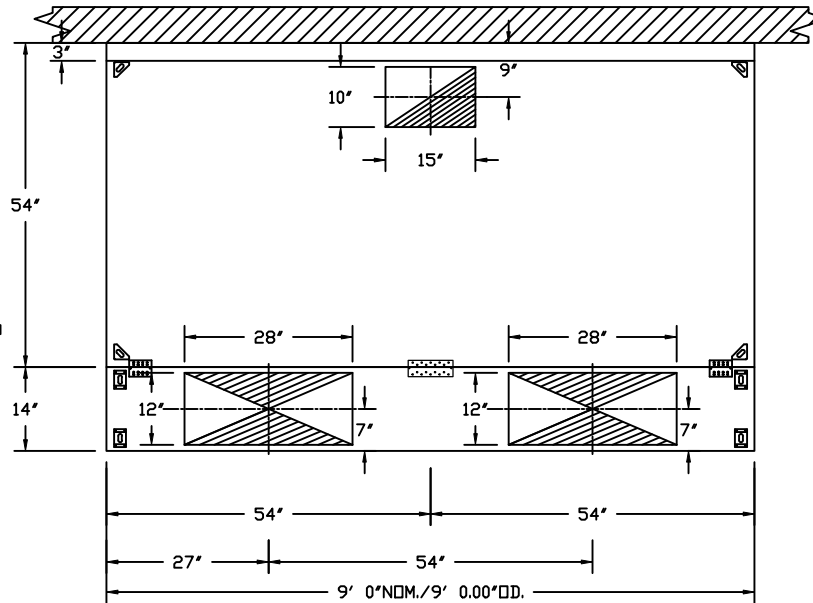

PLAN VIEW - HOOD #1
9' 0.00" LONG 5430ND-2-PSP-F



CAPTIVEAIRE

JOB Dickey's BBQ Slidell Smoker	
LOCATION SLIDELL, LA, 70458	
DATE 3/12/2026	JOB # 2257876
DWG # 1	DRAWN BY MJB
REV.	SCALE 3/8" = 1'-0"

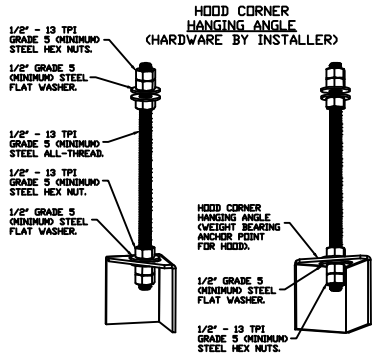

ASSEMBLY INSTRUCTIONS

HANGING ANGLE MUST BE SUPPORTED WITH 1/2" - 13 TPI GRADE 5 (MINIMUM) ALL-THREAD, SANDWICH HANGING ANGLES AND CEILING ANCHOR POINTS WITH 1/2" GRADE 5 (MINIMUM) STEEL FLAT WASHERS AND 1/2" - 13 TPI GRADE 5 (MINIMUM) HEX NUTS AS SHOWN. MUST USE DOUBLED HEX NUT CONFIGURATION BENEATH HOOD HANGING ANGLES AND ABOVE CEILING ANCHORS. MAINTAIN 1/4" OF EXPOSED THREADS BENEATH BOTTOM HEX NUT. TORQUE ALL HEX NUTS TO 57 FT-LBS.

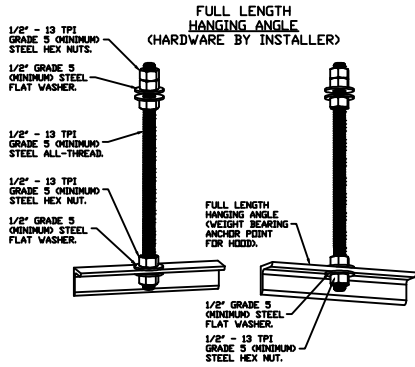

ASSEMBLY INSTRUCTIONS

HANGING ANGLE MUST BE SUPPORTED WITH 1/2" - 13 TPI GRADE 5 (MINIMUM) ALL-THREAD, SANDWICH HANGING ANGLES AND CEILING ANCHOR POINTS WITH 1/2" GRADE 5 (MINIMUM) STEEL FLAT WASHERS AND 1/2" - 13 TPI GRADE 5 (MINIMUM) HEX NUTS AS SHOWN. MUST USE DOUBLED HEX NUT CONFIGURATION ABOVE CEILING ANCHORS. SINGLE HEX NUT BENEATH HANGING ANGLE IS ACCEPTABLE FOR FULL LENGTH HANGING ANGLES. MAINTAIN 1/4" OF EXPOSED THREADS BENEATH BOTTOM HEX NUT. TORQUE ALL HEX NUTS TO 57 FT-LBS.

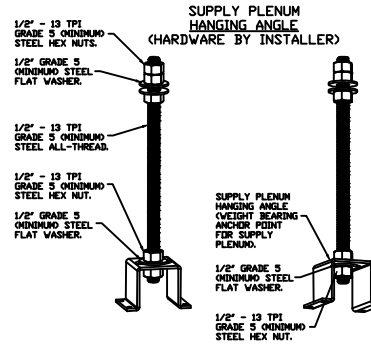

ASSEMBLY INSTRUCTIONS

HANGING ANGLE MUST BE SUPPORTED WITH 1/2" - 13 TPI GRADE 5 (MINIMUM) ALL-THREAD, SANDWICH HANGING ANGLES AND CEILING ANCHOR POINTS WITH 1/2" GRADE 5 (MINIMUM) STEEL FLAT WASHERS AND 1/2" - 13 TPI GRADE 5 (MINIMUM) HEX NUTS AS SHOWN. MUST USE DOUBLED HEX NUT CONFIGURATION ABOVE CEILING ANCHORS. SINGLE HEX NUT BENEATH HANGING ANGLE IS ACCEPTABLE FOR PSP HANGING ANGLES. MAINTAIN 1/4" OF EXPOSED THREADS BENEATH BOTTOM HEX NUT. TORQUE ALL HEX NUTS TO 57 FT-LBS.

CLEARANCE TO COMBUSTIBLES

HOODS #	SURFACE	≠CLEARANCE
1	TOP	18"
	FRONT	0"
	BACK	18"
	LEFT	18"
	RIGHT	18"

- ≧0" CLEARANCE TO COMBUSTIBLES CONFORMS TO UL710 STANDARD.



CAPTIVEAIR

JOB Dickey's BBQ Slidell Smoker	
LOCATION SLIDELL, LA, 70458	
DATE 3/12/2026	JOB # 2257876
DWG # 2	DRAWN BY MJB
REV.	SCALE 3/8" = 1'-0"

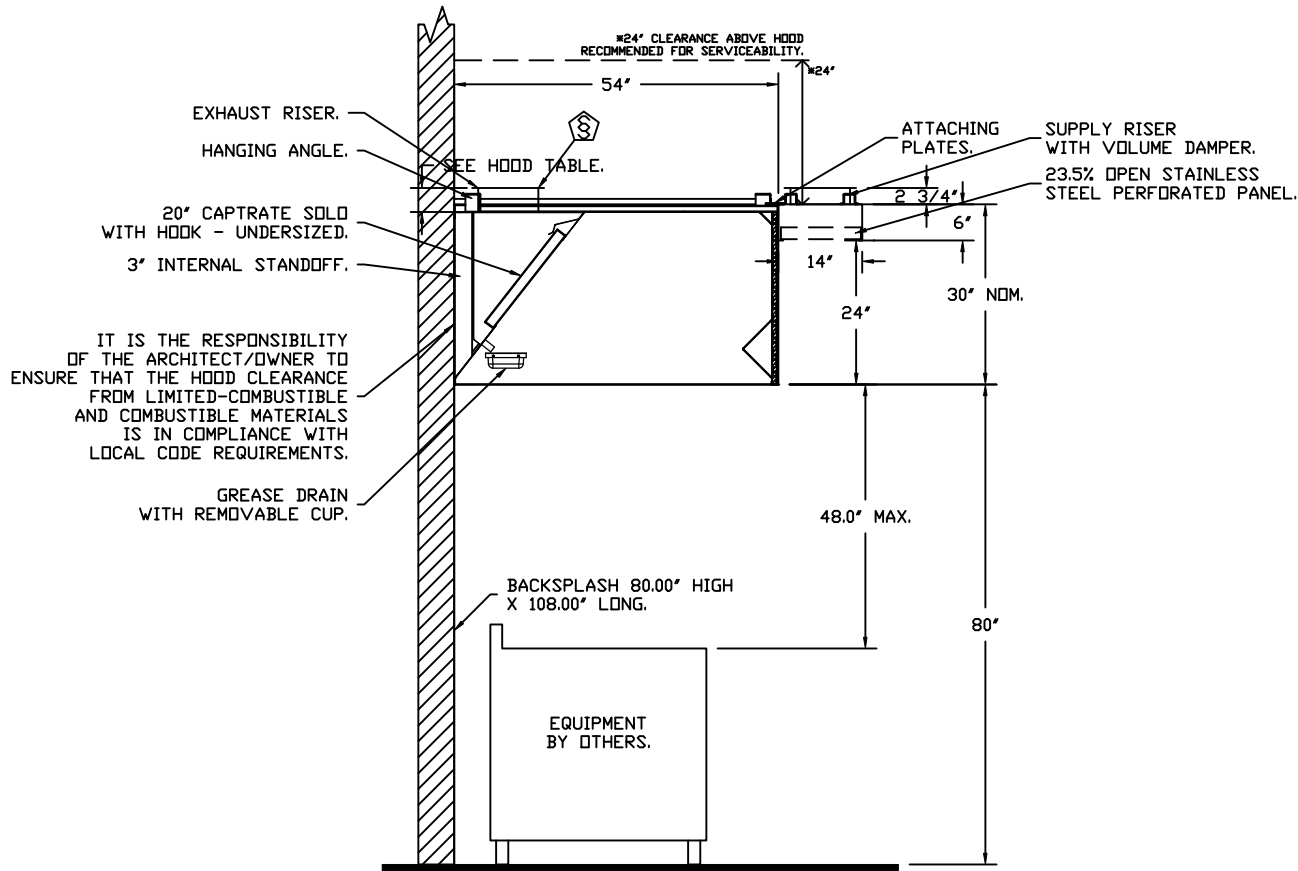

**SECTION VIEW - MODEL 5430ND-2-PSP-F
HOOD - #1**

  	
--	---

JOB Dickey's BBQ Slidell Smoker	
LOCATION SLIDELL, LA, 70458	
DATE 3/12/2026	JOB # 2257876
DWG # 3	DRAWN BY MJB
REV.	SCALE 3/8" = 1'-0"

BACKSPLASH

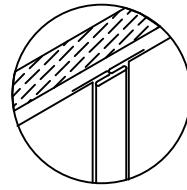
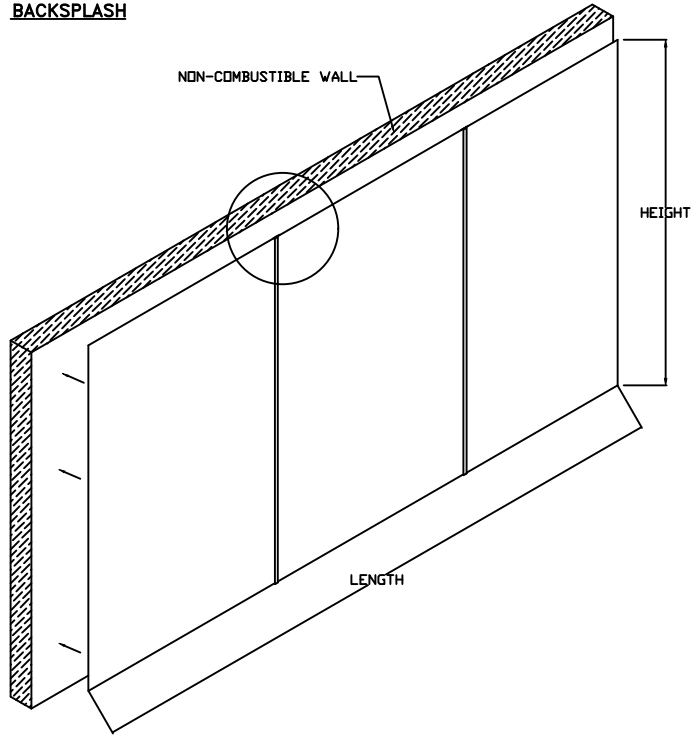

BACKSPLASH PANELS
SLIDE INTO DIVIDER
BAR

- BACKSPLASH IS NOT
INSULATED AND IS UNSUITABLE
FOR INSTALL AGAINST
COMBUSTIBLE WALLS



CAPTIVEAIR

<i>JOB</i> Dickey's BBQ Slidell Smoker	
<i>LOCATION</i> SLIDELL, LA, 70458	
<i>DATE</i> 3/12/2026	<i>JOB #</i> 2257876
<i>DWG #</i> 4	<i>DRAWN BY</i> MJB
<i>REV.</i>	<i>SCALE</i> 3/8" = 1'-0"

EXHAUST FAN INFORMATION - JOB#2257876

FAN UNIT NO	TAG	QTY	FAN UNIT MODEL #	MANUFACTURER	CFM	ESP	RPM	MOTOR ENCL	HP	BHP	PHASE	VOLT	FLA	DISCHARGE VELOCITY	WEIGHT (LBS)	SONES
1		1	NCA14HPFA	CAPTIVEAIRE	1665	0.750	1365	DDP	0.500	0.4660	1	208	4.3	527 FPM	116	14.2

MUA FAN INFORMATION - JOB#2257876

FAN UNIT NO	TAG	QTY	FAN UNIT MODEL #	BLOWER	HOUSING	MIN CFM	DESIGN CFM	ESP	RPM	MOTOR ENCL	HP	BHP	PHASE	VOLT	FLA	MCA	MDCP	WEIGHT (LBS)	SONES
2		1	A1-G10	G10	A1	-	1498	0.500	717	DDP	0.500	0.2890	1	208	4.3	5.4A	15A	250	11.5

FAN ACCESSORIES

FAN UNIT NO	TAG	EXHAUST			SUPPLY			
		GREASE CUP	GRAVITY DAMPER	WALL MOUNT	SIDE DISCHARGE	GRAVITY DAMPER	MOTORIZED DAMPER	WALL MOUNT
1		YES						

CURB ASSEMBLIES

NO	DN FAN	WEIGHT	ITEM	SIZE
2	# 2	29 LBS	CURB	21.000"W X 21.000"L X 20.000"H 1.000:12.000 PITCH.



CAPTIVEAIRE

<i>JOB</i> Dickey's BBQ Slidell Smoker	
<i>LOCATION</i> SLIDELL, LA, 70458	
<i>DATE</i> 3/12/2026	<i>JOB #</i> 2257876
<i>DWG #</i> 5	<i>DRAWN BY</i> MJB
<i>REV.</i>	<i>SCALE</i> 3/8" = 1'-0"

FAN OPTIONS

FAN UNIT NO	TAG	QTY	DESCRIPTION
1		1	GREASE BOX
		1	2 YEAR PARTS WARRANTY
2		1	2 YEAR PARTS WARRANTY

  	JOB Dickey's BBQ Slidell Smoker LOCATION SLIDELL, LA, 70458	
	DATE 3/12/2026	JOB # 2257876
	DWG # 6	DRAWN BY MJB
	REV.	SCALE 3/8" = 1'-0"
		

FAN #1 NCA14HPFA - EXHAUST FAN

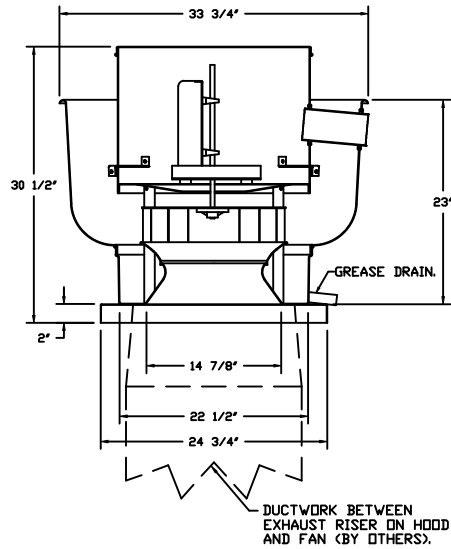

FEATURES:

- ROOF MOUNTED FANS.
- RESTAURANT MODEL.
- UL705 AND UL762 AND ULC-S645.
- AMCA SOUND AND AIR CERTIFIED.
- WIRING FROM MOTOR TO DISCONNECT SWITCH.
- NEMA 3R SAFETY DISCONNECT SWITCH.
- HIGH HEAT OPERATION 300°F (149°C).
- GREASE CLASSIFICATION TESTING.

NORMAL TEMPERATURE TEST
EXHAUST FAN MUST OPERATE CONTINUOUSLY WHILE EXHAUSTING AIR AT 300°F (149°C) UNTIL ALL FAN PARTS HAVE REACHED THERMAL EQUILIBRIUM AND WITHOUT ANY DETERIORATING EFFECTS TO THE FAN WHICH WOULD CAUSE UNSAFE OPERATION.

ABNORMAL FLARE-UP TEST
EXHAUST FAN MUST OPERATE CONTINUOUSLY WHILE EXHAUSTING BURNING GREASE VAPORS AT 600°F (316°C) FOR A PERIOD OF 15 MINUTES WITHOUT THE FAN BECOMING DAMAGED TO ANY EXTENT THAT COULD CAUSE AN UNSAFE CONDITION.

OPTIONS

- GREASE BOX.
- 2 YEAR PARTS WARRANTY.

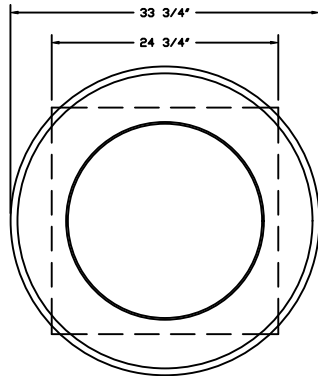

TOP VIEW



CAPTIVEAIR

JOB Dickey's BBQ Slidell Smoker	
LOCATION SLIDELL, LA, 70458	
DATE 3/12/2026	JOB # 2257876
DWG # 7	DRAWN BY MJB
REV.	SCALE 3/8" = 1'-0"

- FAN #2 A1-G10 - SUPPLY FAN
 1. UNTEMPERED SUPPLY UNIT WITH 10" BLOWER IN SIZE #1 HOUSING.
 2. INTAKE HOOD WITH EZ FILTERS.
 3. DOWN DISCHARGE - AIR FLOW RIGHT -> LEFT.
 4. 2 YEAR PARTS WARRANTY.

NOTE: SUPPLY DUCT MUST BE INSTALLED TO MEET SMACNA STANDARDS. A MINIMUM STRAIGHT DUCT LENGTH MUST BE MAINTAINED DOWNSTREAM OF UNIT DISCHARGE AS OUTLINED IN AMCA PUBLICATION 201. WHEN USING RECTANGULAR DUCTWORK, ELBOWS MUST BE RADIUS THROAT, RADIUS BACK WITH TURNING VANES. FLEXIBLE DUCTWORK AND SQUARE THROAT/SQUARE BACK ELBOWS SHOULD NOT BE USED. ANY TRANSITION AND/OR TURNS IN THE DUCTWORK WILL CAUSE SYSTEM EFFECT. SYSTEM EFFECT WILL DRASTICALLY INCREASE STATIC PRESSURE AND REDUCE AIRFLOW. DO NOT RELY ON UNIT TO SUPPORT DUCT IN ANY WAY. FAILURE TO PROPERLY SIZE DUCTWORK MAY CAUSE SYSTEM EFFECTS AND REDUCE PERFORMANCE OF THE EQUIPMENT. SUGGESTED SUPPLY STRAIGHT DUCT SIZE IS 14" x 14".

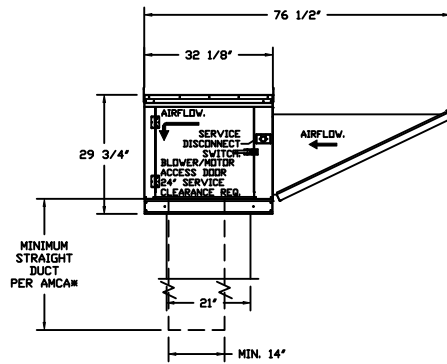
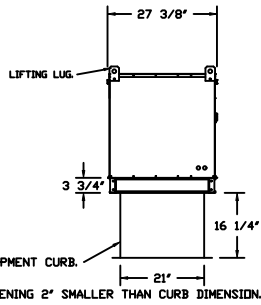
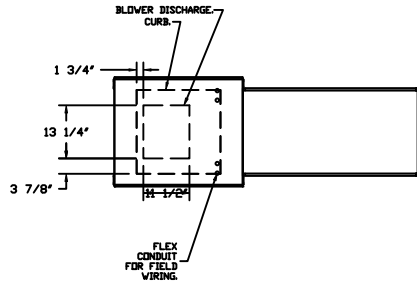

PITCHED CURBS ARE AVAILABLE FOR PITCHED ROOFS.
 SPECIFY PITCH:
 EXAMPLE: 7/12 PITCH = 30° SLOPE.

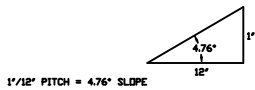
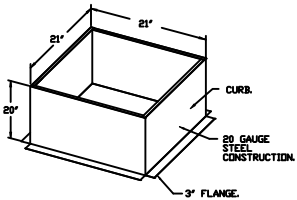

CAPTIVEAIR

JOB Dickey's BBQ Slidell Smoker	
LOCATION SLIDELL, LA, 70458	
DATE 3/12/2026	JOB # 2257876
DWG # 8	DRAWN BY MJB
REV.	SCALE 1/4" = 1'-0"

Exhaust Fan Wiring

JOB 2257876 - Dickeys BBQ Sidelall Smoker

DRAWING NUMBER EXH2257876-1

SHIP DATE 3/5/2015

MODEL NCA14HPPA

Installed Options

- 1
- 2
- 3
- 4
- 5
- 6
- 7
- 8
- 9
- 10
- 11
- 12
- 13
- 14
- 15
- 16
- 17
- 18
- 19
- 20
- 21
- 22
- 23

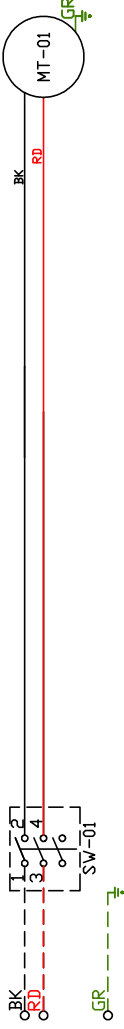

Label	Component Description	Location
MT-01	Fan Motor	[3]
SV-01	Main disconnect switch	[3]

EXHAUST MOTOR_INFD 0.5HP-208V-1P-4.3FLA

ELECTRICAL INFORMATION
 MOTOR/CTRL SWA
 MOTOR/CTRL MOP: 15A

NOTES
 --- DENOTES FIELD WIRING
 - - - DENOTES INTERNAL WIRING

WIRE COLOR
 BK - BLACK YW - YELLOW
 BL - BLUE GR - GREEN
 BR - BROWN GY - GRAY
 OR - ORANGE PR - PURPLE
 RD - RED PK - PINK
 WH - WHITE

AirHandler Wiring

JOB 2257876 - Dickey's BBQ Sidel'l Smoker

DRAWING NUMBER A2257876-2

SHIP DATE 3/5/2015

MODEL A1-G10

ATTENTION ELECTRICIAN!
 DROP FOR DISCONNECT CONNECTION
 IS FACTORY SUPPLIED
 CONNECT POWER TO THE DROP

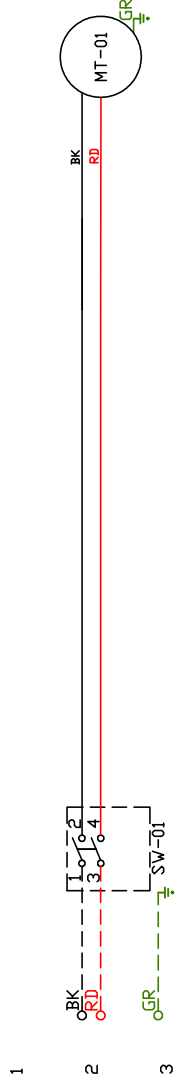

Installed Options

Label	Description	Location
MT-01	Supply motor	[2]
SW-01	Main disconnect switch	[2]

Location

MT-01 Supply motor [2]

SW-01 Main disconnect switch [2]

SUPPLY MOTOR_INFD 0.5HP-208V-1P-4.3FLA

ELECTRICAL INFORMATION
 MOTOR/CTRL CIRCUIT MOP: 54A
 MOTOR/CTRL CIRCUIT MOP: 15A

NOTES
 --- DENOTES FIELD WIRING
 --- DENOTES INTERNAL WIRING

WIRE COLOR
 BK-BLACK YW - YELLOW RD - RED
 BL-BLUE GR - GREEN WH - WHITE
 BR - BROWN GY - GRAY PK - PINK
 OR - ORANGE PR - PURPLE

1
2
3
4
5
6
7
8
9
10
11
12
13
14
15
16
17
18
19
20
21
22
23

ELECTRICAL PACKAGE – JOB#2257876

NO	TAG	PACKAGE #	LOCATION	SWITCHES		OPTION	FANS CONTROLLED				
				LOCATION	QUANTITY		TYPE	Φ	HP	VOLT	FLA
1		SC-211110FP	WALL MOUNT IN SS BOX	FACE MOUNT RIGHT	1 LIGHT	SMART CONTROLS THERMOSTATIC CONTROL	EXHAUST	1	0.500	208	4.3
				SIDE OF HOOD			SUPPLY				
				HOOD # 1			1 FAN				

  	<i>JOB</i> Dickey's BBQ Slidell Smoker	
	<i>LOCATION</i> SLIDELL, LA, 70458	
	<i>DATE</i> 3/12/2026	<i>JOB #</i> 2257876
	<i>DWG #</i> 11	<i>DRAWN BY</i> MJB
	<i>REV.</i>	<i>SCALE</i> 3/8" = 1'-0"

CAPTIVEAIR

JOB NO
2257876

MODEL NUMBER
SC-21110FP

JOB NAME
Dickeys BBQ Sldell Smoker

DRAWN BY
INSTALL

DATE
3/12/2026

SCHEMATIC TYPE
DWG NO
ECP #1-1

DESCRIPTION OF OPERATION:
220V 1 Phase w/ control for 1 Exhaust Fan, 1 Supply Fan, Exhaust on in Fire, Lights out in Fire, Fans On/Off
Thermostatically Controlled. Room temperature sensor shipped loose for field installation.

BREAKER PANEL TO PRIMARY CONTROL PANEL

Responsibility: Electrician

BREAKER SIZE SHOWN IS THE MAXIMUM ALLOWED

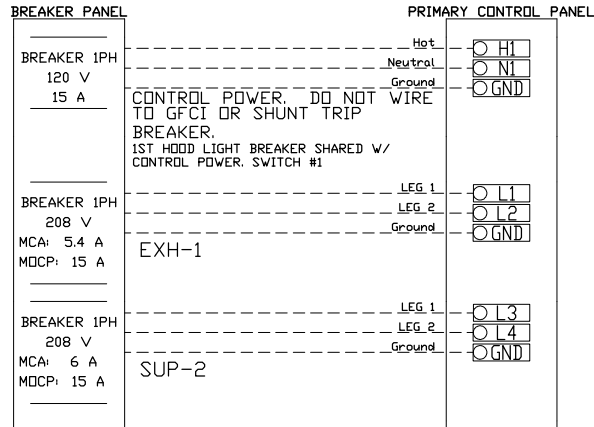

CONTROL PANEL TO ACCESSORY ITEMS

Responsibility: Electrician

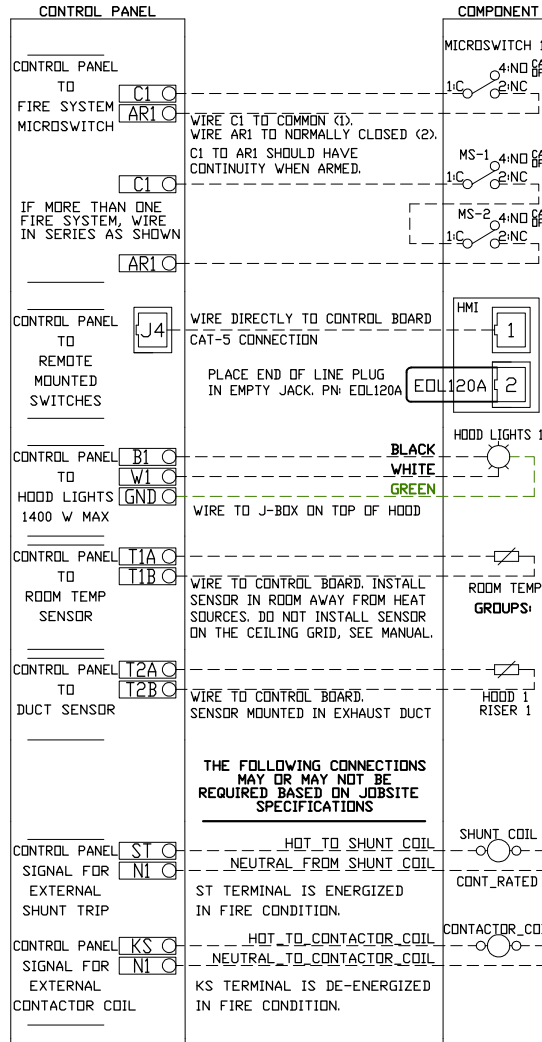

CONTROL PANEL TO FANS

Responsibility: Electrician

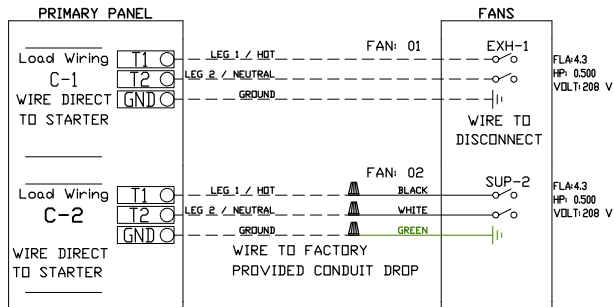

UNLESS SPECIFIED OTHERWISE, ALL FACTORY AC WIRING 16 AWG. ALL FACTORY DC WIRING 18 AWG.

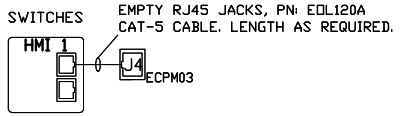
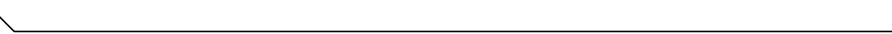
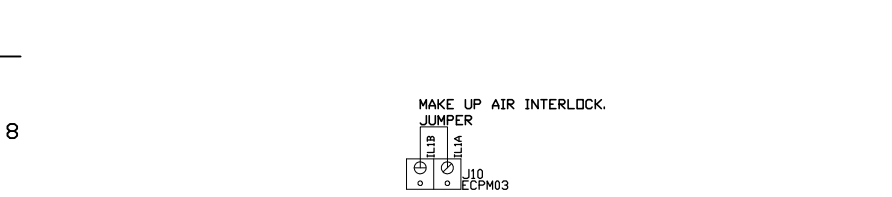
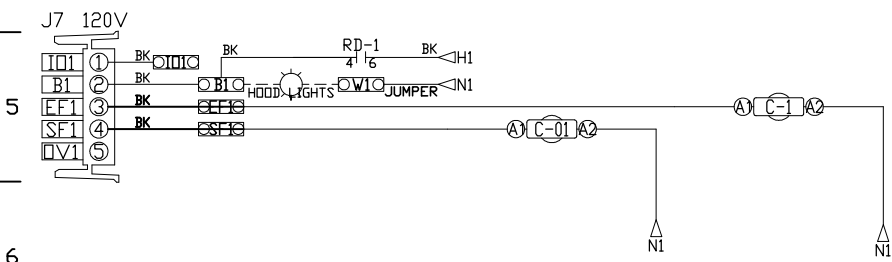
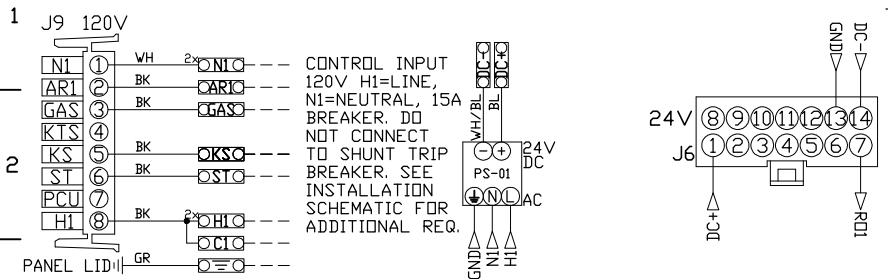

MOTOR POWER CIRCUIT

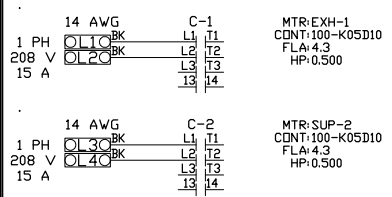

FACTORY WIRING SCHEMATIC
ECPM03 Rev. 1.36
HMI Rev. 1.06

RA-x	120 VAC	RD-x	24 VDC
RELAY		RELAY	
NO	4 3	14	NO
NC	2 1	12	NC
COIL	8 7	+A1A2	COIL
COM	6 5	11	COM

COMPONENT LIST

LABEL	DESCRIPTION
ST-X	Starter PN-varies
OL-X	Overload PN-varies
C-X	Contactor PN-varies
PS-1	Power Sup. 24VDC PN: MDP18-24A-1C
RA-x	120V Relay DPDT PN: 34.110.0184.0
RD-x	24VDC Light Relay PN: 34.110.0188.0

LEGEND

--- FIELD WIRING
--- FACTORY WIRING

BK- BLACK YW- YELLOW
BL- BLUE GY- GREY
BR- BROWN PR- PURPLE
OR- ORANGE RD- RED
WH- WHITE
DR/BL- DR/BL STRIPE
BL/RD- BL/RD STRIPE
RD/GN- RD/GN STRIPE
WH/BL- WH/BL STRIPE

JOB NAME
Dickeys BBQ Sld...

DRAWING TITLE
SC-211110FP

DESCRIPTION OF OPERATION
220V 1 Phase w/ control for 1 Exhaust Fan, 1 Supply Fan, Exhaust on in Fire, Lights out in Fire, Fans On/Off Thermostatically Controlled. Room temperature sensor shipped loose for field installation.

JOB NO	DRAWN BY
2257876	
TYPE	DATE
FACTORY	3/12/2026
DWG NO ECP	#1-2

DRY CONTACTS (SHOWN DE-ENERGIZED)

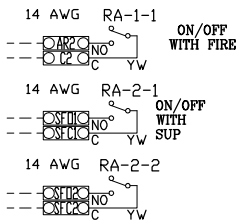

14 x 18 x 6 Box