

FEATURES

- Vitreous china
- Wall-mount
- Brushed chrome lever-operated fitting
- 1-1/4" trap with brushed chrome strainer

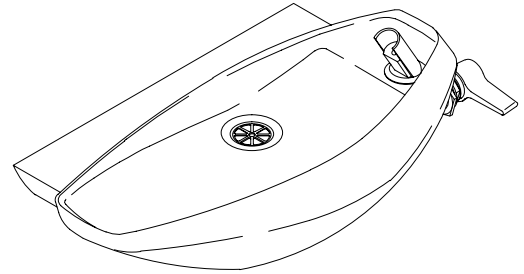

CODES/STANDARDS APPLICABLE

Specified model meets or exceeds the following:

- ASME/ANSI A112.19.2M
- IAPMO/UPC
- Canadian Standards Association (CSA)
- NSF 61 section 9
- States of Massachusetts, New York, & Texas

COLORS/FINISHES

- 0 White
- Other Refer to Fixtures Price Book for additional colors

Accessories:

- NA None Applicable

SPECIFIED MODEL:

Model	Description	Colors/Finishes	
K-5250	Drinking fountain	<input type="checkbox"/> 0 White	<input type="checkbox"/> Other _____

PRODUCT SPECIFICATION:

The wall-mount drinking fountain shall be made of vitreous china. Drinking fountain shall have brushed chrome lever-operated fitting and 1-1/4" trap with brushed chrome strainer. Drinking fountain shall be Kohler Model K-5250-_____.

PRODUCT INFORMATION

Included Components:	
Hanger accessory pack	52046
Supply fitting sub-assembly	79187
Trap with strainer	35312
Bottom access plate assembly	35268
Side access plate assembly	35266
Supply stop sub-assembly	35308

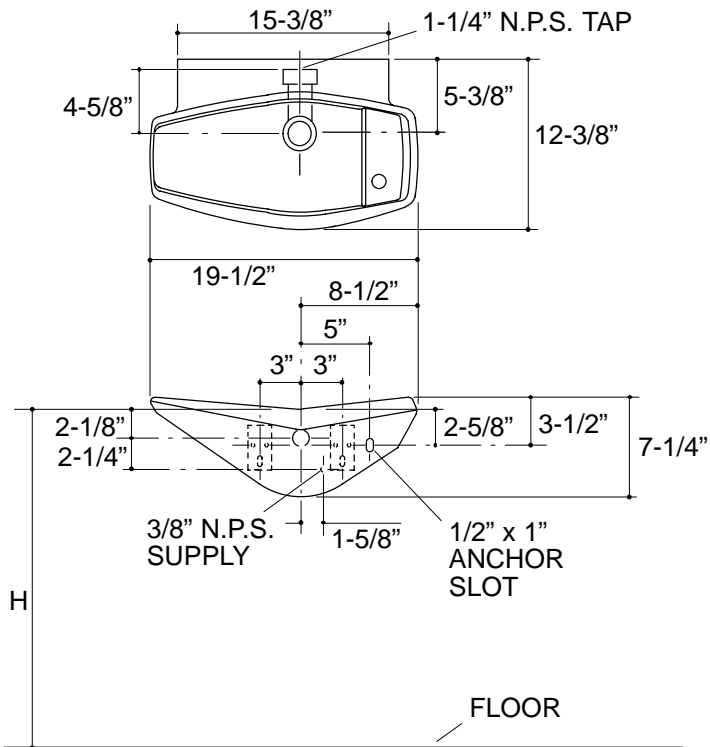

Roughing-In Notes

H 30" for grade school.
 36" to 44" for other buildings.
 36" max. to comply with ADA. Must be built-in for knee clearance.

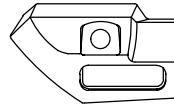

1.15>116

PRODUCT DIAGRAM