

Ordering Information

Applicable product:		
With neck jets	K-702-N	shown
Without neck jets	K-702-H1	not shown
Accessories/hardware:		
Jet trim kit	K-9695	required
Drain	K-7158	recommended

Required Electrical Service

Dedicated circuit required, protected with Class A Ground-Fault Circuit-Interrupter (GFCI):	
Pump/control	120 V., 20 A, 60 Hz

Product Information

Fixture*:	basin area	top area	weight
Bathing well	1118 x 610mm	1524 x 813mm	247 Kg.
	water depth	capacity	
To overflow	381mm	310 litres	
* Approximate measurements for comparison only.			

Pump:	HP	V	Hz	A
1-speed	2	120	60	18.5

Included Components:	
Cutout template	106594-7

Installation Notes

Refer to installation instructions included with fixture before beginning installation.

NOTICE: The floor must support 906 Kg. This is the combined weight of the bath, water, and two bathers. Pre-plan access for moving the bath into the construction area; the bath is heavy and will not fit easily through doorways.

Pump is supplied with a grounding type plug-in cord. Locate the outlet behind the whirlpool, and within 610mm of the pump.

Roughing-In Notes		
Fixture dimensions are nominal and conform to tolerances in ANSI Standard A112.19.1.		
No change in measurements if connected with drain illustrated.		
Minimum access panel:		
Pump/control	1016mm W x 381mm H panel	required

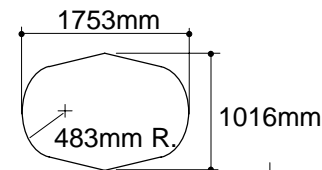

CUTOUT DETAIL

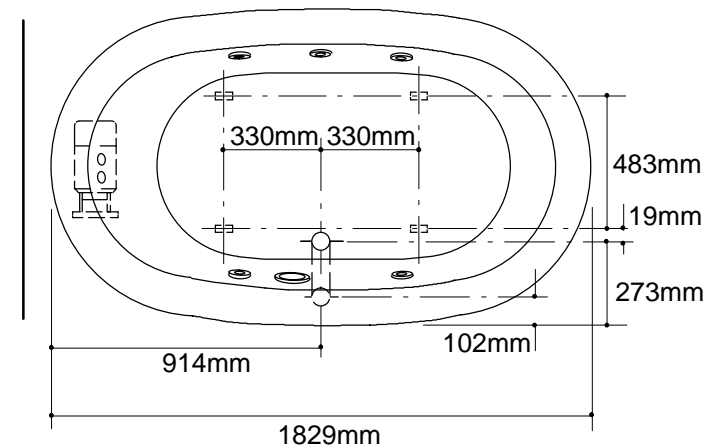
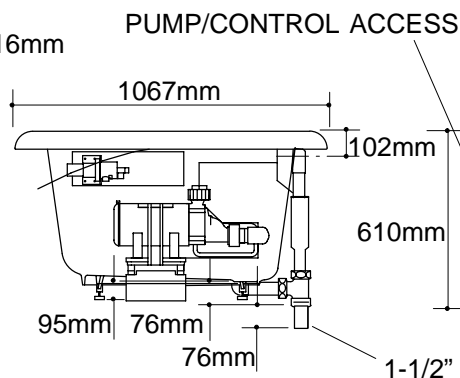

1.25>132