

## Ordering Information

Applicable product:		
With neck jets	K-812-N	shown
Without neck jets	K-812-H1	not shown
Accessories/hardware:		
Jet trim kit	K-9696	required
Drain	K-7161-AF	recommended
Undermount installation kit	K-581	optional
Grip rails	K-9616	required
Vinyl tiling-in bead*	K-1179	optional
*Use K-1179 vinyl bead when wall material contacts any top surface of bath.		

## Required Electrical Service

Dedicated circuit required, protected with Class A Ground-Fault Circuit-Interrupter (GFCI):	
Pump/control	120 V., 20 A, 60 Hz

## Product Information

Fixture*:	basin area	top area	weight
Bathing well	1194 x 610mm	1702 x 737mm	193 Kg.
	water depth	capacity	
To overflow	327mm	197 litres	

\* Approximate measurements for comparison only.

Pump:	HP	V	Hz	A
1-speed	2	120	60	18.5

## Installation Notes

Refer to installation instructions included with fixture before beginning installation.

Pump is supplied with a grounding type plug-in cord. Locate the outlet behind the whirlpool, and within 610mm of the pump.

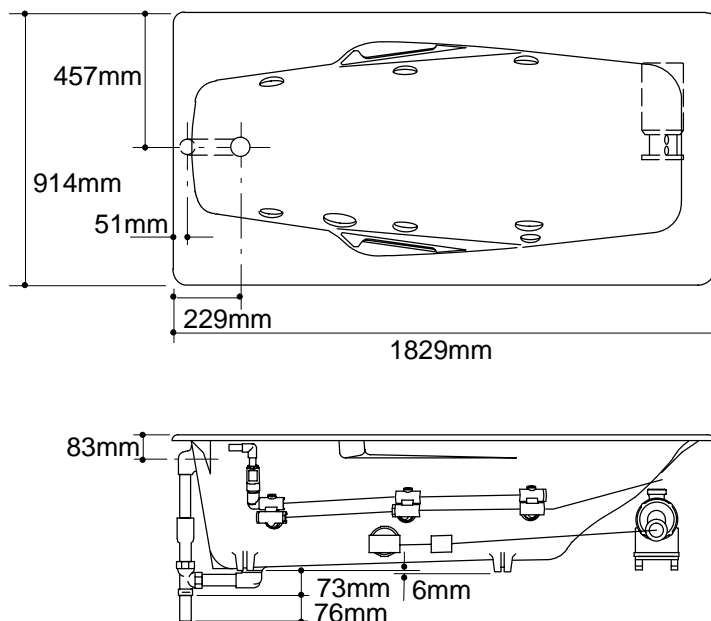

## Roughing-In Notes

Fixture dimensions are nominal and conform to tolerances in ANSI Standard A112.19.

No change in measurements if connected with drain illustrated.

Cut-out for drop-in	1791 x 876mm
Cut-out for undermount	K-581 template required
Minimum access panel:	
Pump/control	864mm W x 381mm H panel required

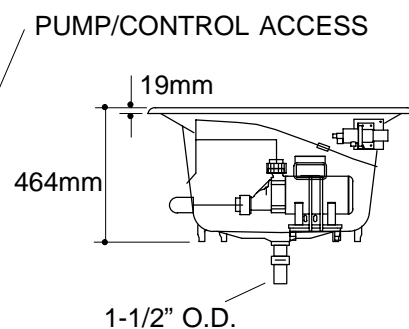

1.25>132