

**FEATURES**

- Brass construction
- 5-3/4" spout with N.P.T. connection
- Traditional handle
- Push-button diverter
- Available with contrasting or matching finish faceplate and handle accents

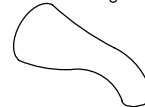
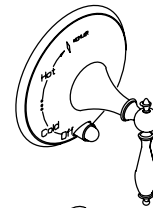
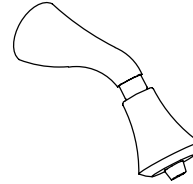

**CODES/STANDARDS APPLICABLE**

Specified model meets or exceeds the following:

- ASME/ANSI A112.18.1M
- ASSE/ANSI 1016
- CSA B125
- IAPMO/UPC

**COLORS/FINISHES**

- CP Polished Chrome
- PB Polished Brass
- Other Refer to Faucets Price Book for additional finishes

**SPECIFIED MODEL:** For complete faucet, both faucet trim and Rite-Temp valve must be specified.

Model	Description			
K-T312-4F	With Biscuit Accents	<input type="checkbox"/> CP	<input type="checkbox"/> PB	
K-T312-4M	With Polished Finish Accents	<input type="checkbox"/> CP	<input type="checkbox"/> PB	<input type="checkbox"/> Other_____
K-T312-4P	With White Accents	<input type="checkbox"/> CP	<input type="checkbox"/> PB	

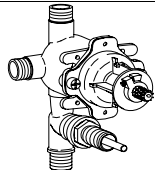
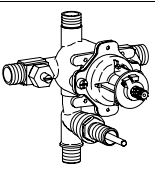
Required Accessory		 	
K-305-K	Rite-Temp Valve With Push-Button Diverter, Without Stops	<input type="checkbox"/> NA	
K-305-KS	Rite-Temp Valve With Push-Button Diverter, With Stops		<input type="checkbox"/> NA

**PRODUCT SPECIFICATION:**

Rite-Temp pressure-balancing single-control bath and shower faucet trim shall be of brass construction. Product shall include showerhead with arm, 5-3/4" spout with N.P.T. connection, faceplate with traditional handle, and push-button diverter. Faucet trim shall be Kohler Model K-T312-\_\_\_\_\_-\_\_\_\_\_- and Rite-Temp valve shall be K-305-\_\_\_\_\_-NA.

# FINIAL TRADITIONAL

## INSTALLATION NOTES

Avoid cross-flow conditions. Do not install shut-off device on either valve outlet.

Cap shower outlet if deck-mount spout, diverter, or handshower is connected to spout outlet.

Install straight pipe or tube drop of 7 to 18" with single elbow between valve and wall-mount spout.

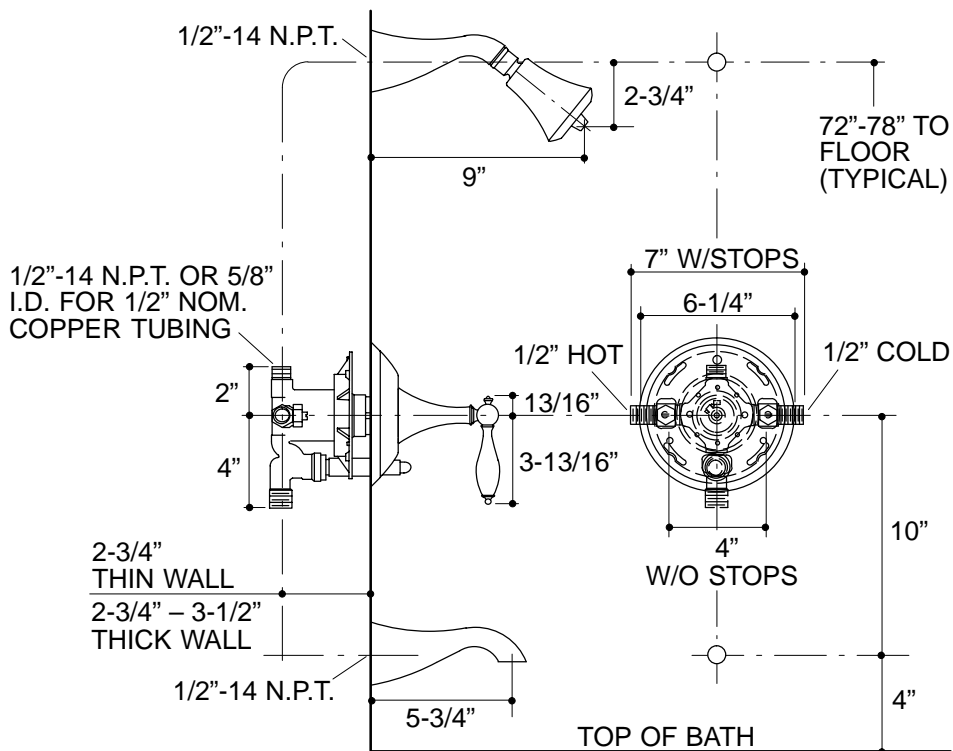

18

## PRODUCT DIAGRAM