

FEATURES

- 75" D. x 25" high, (27-1/2" high with pillow)
- Acrylic
- System III - with two 2 hp variable flow pumps with integral heater, and electronic switches
- 8 Flexjets
- Waterfall
- 4 Riverjets
- UL Listed
- LESS ALL TRIM
- One large pillow and three small pillows
- Pumps are supplied with grounding-type plug-in cords

K-1399

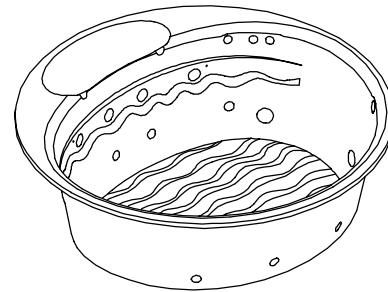

CODES/STANDARDS APPLICABLE

Specified model meets or exceeds the following:

- ANSI Z124.1
- ASME/ANSI A112.19.7M
- Underwriters Laboratories (UL)

COLORS/FINISHES

- 0 White
- Other Refer to Fixtures Price Book for additional colors

Accessories:

- CP Polished Chrome
- PB Polished Brass
- Other Refer to Faucets Price Book for additional finishes

SPECIFIED MODEL:

Model	Description	Colors/Finishes		
K-1399	RiverBath	<input type="checkbox"/> 0 White	<input type="checkbox"/> Other_____	
Required Accessory				
K-9661	Flexjet trim kit	<input type="checkbox"/> CP	<input type="checkbox"/> PB	<input type="checkbox"/> Other_____
Recommended Accessory				
K-7167	Drain	<input type="checkbox"/> CP	<input type="checkbox"/> PB	<input type="checkbox"/> Other_____

PRODUCT SPECIFICATION:

The RiverBath shall be 75" in diameter, and 25" in height (27-1/2" in height with pillow). RiverBath shall be made of acrylic. RiverBath shall have System III, with 8 Flexjets, waterfall, 4 Riverjets, two 2 hp variable flow pumps with integral heater, and electronic switches. RiverBath shall be UL listed. RiverBath shall be less all trim. RiverBath shall have one large pillow and three small pillows. RiverBath pumps shall be supplied with grounding-type plug-in cords. RiverBath shall be Kohler Model K-1399-_____.

RIVERBATH™

REQUIRED ELECTRICAL SERVICE

Two separate dedicated circuits required, each protected with Class A Ground-Fault Circuit-Interrupter (GFCI):	
Pump/control, (waterfall)	120 V., 20 A, 60 Hz
Pump/control, (jets)	120 V., 20 A, 60 Hz

PRODUCT INFORMATION

Fixture*:	basin area	top area	weight	
Bathing well	61" x 46"	68" x 58"	240 lbs.	
	water depth	capacity		
To overflow	20"	215 gal.		
* Approximate measurements for comparison only.				
Pump: (Qty. 2)	HP	V	Hz	A
1-speed	2	120	60	18.5
Included Components:				
Cutout template	85899-7			

INSTALLATION NOTES

NOTICE: The floor must support 3,000 pounds.

Pumps are supplied with grounding-type plug-in cords. Locate the outlets behind the RiverBath, and within 24" of the pumps.

If installing a rim-mount faucet, make sure there is no interference with drain overflow and circulating system before drilling any holes. Consult local and national codes for minimum air gap requirements if installing a spout on the faucet deck other than that supplied.

Two 60 gallon (120 gallon total) water heaters are necessary to fill RiverBath.

Roughing-In Notes

No change in measurements if connected with drain illustrated.

Faucet area		recommended
Minimum access panel:		
Pump/control	48" W x 18" H	required

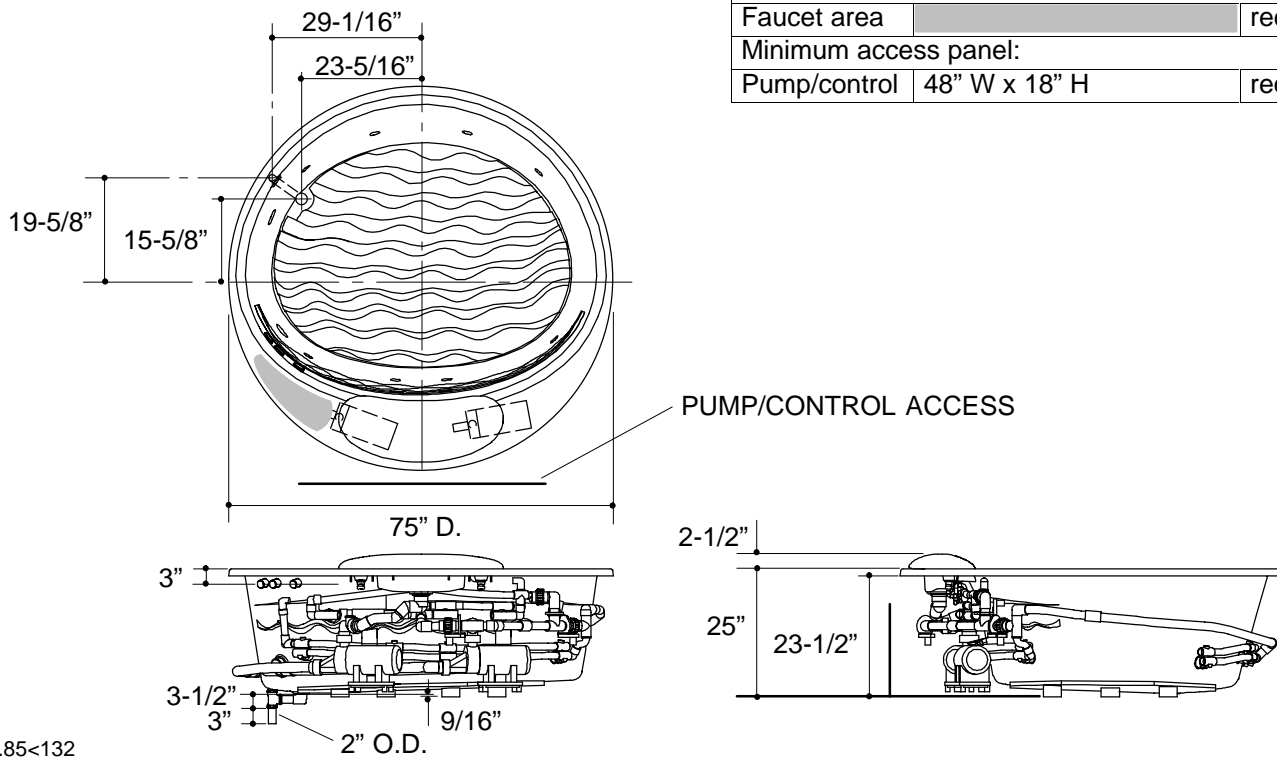

PRODUCT DIAGRAM