

**AKSA Power Generation** has been producing industrial generator sets with an innovative compact design and excellence in quality for over 30 years. AKSA has been providing reliable power through three main production plants and over 15 branch offices worldwide.

Alternator (125 °C Rise)	Voltage	Ph	Pf	Hz	Stand-by Ratings		Prime Ratings	
					kW/kVA	Amp	kW/kVA	Amp
	480/277V	3	0.8	60	350/438	526	320/400	481
	440/254V	3	0.8	60	350/438	574	320/400	525
HCI434E Winding #311	416/240V	3	0.8	60	350/438	607	320/400	555
	240/139V	3	0.8	60	350/438	1052	320/400	962
	240/120V	3	0.8	60	350/438	1052	320/400	962
	208/120V	3	0.8	60	350/438	1214	320/400	1110



## Rating Definition

**Stand-by Power (Maximum):** Power available at variable load in the event of main power network failure. No over load is permitted.

**Prime Power:** Power available at variable load in lieu of a main power network. Overload of 10% is permitted for 1 hour in every 12 hours of operation. The above ratings represent the engine performance capabilities to conditions specified in accordance with ISO 8528/5 & ISO3046.

**Derating may be required for conditions outside of the test conditions.**

## Codes & Standards

### U.S.EPA

EPA Certified **Tier3** for Emergency Stationary Applications.



The Generator set is **UL2200 listed**. Dual wall **UL142** listed fuel tanks are also available.



The Generator set is designed and manufactured in a facility certified to **ISO9001** standards.



The Generator set is designed and manufactured in a facility certified to **ISO14001:2004** standards.



The Generator meets **NFPA70, 99, 110, 37** Level 1 when equipped with the necessary accessories and installed per NFPA standards.

## Standard Features

**AKSA Power Generation** provides **single source responsibility** for the generator set & accessories.

The generator set, with its components, are **prototype tested** and **production tested** according to the UL test program.

**Perkins heavy duty** four cycle industrial diesel engine delivers low emission, reliable power, fuel efficiency and fast response to load changes.

**Newage Stamford** industrial generators meet the requirements of BS EN 60034 and the relevant sections of other international standards such as BS5000, VDE0530, NEMA MG1-32, IEC34, CSA C22.2-100, AS1359.

**Non-proprietary NFPA110** compliant **control system** provides total gen-set system integrated control, protections, metering, automatic starting/stopping with options of remote control, remote display or remote annunciation.

**Heavy duty base frame** with integral pad **vibration isolators** eliminates the need for under unit spring vibration isolators.

## Engine Data

Manufacturer	<b>Perkins</b>
Model	<b>2206D-E13TAG2</b>
Cylinders	6, in-line
Max. power @ rated rpm; kWm (BHP)	407 (546)
Brake mean effective pressure; kPa	2171
Aspiration & Cooling	Turbo charged, air to air charge cooling
Total displacement; L (in <sup>3</sup> )	12.5 (762.8)
Bore; in. (mm)	5.12 (130)
Stroke; in. (mm)	6.2 (157)
Compression ratio	16.3:1
Governor type	Electronic, ISO8528-5 Class G2
Rated rpm	1800
Rotation	Anti-clockwise viewed on flywheel

## Engine Electrical System

Charging alternator	24V, Negative Ground
Alternator rating; (amp)	70
Starter motor power; (kW)	7.8
Starter motor rated voltage; (dc)	24
Battery quantity x rating & CCA	2 x 120Ah, 850

## Fuel System

Injector System	MEUI
Injector Pressure: MPa	207
Fuel supply connection size	5/8" NPT
Fuel return connection size	5/8" NPT
Max. fuel lift; m (ft)	4 (13.12)
Lift pump delivery; L/h	600
Max fuel inlet temperature; °C (°F)	55 (131)
Fuel filter & water separator	Available

## Fuel Consumption (gph)

110% Load	24.6
100% Load	23.0
75% Load	17.7
50% Load	12.7

## Exhaust System

Exhaust gas flow; (m <sup>3</sup> /min)	76.6
Max. back pressure; (kPa)	10
Max. exhaust gas temp, turbocharger out; (°C)	680
Exhaust outlet size; (mm)	123

## Cooling System

Radiator ambient temp; °C (°F)	50 (122)
Coolant capacity; L (gal)	51.4 (13.6)
Coolant pump drive	Gear
Coolant flow; L/sec	6.7
Thermostat operation range; °C	87-98
Cooling fan type	Pusher
Cooling fan air flow; m <sup>3</sup> /min	788
Combustion air flow; m <sup>3</sup> /min	26.6
Engine coolant flow; L/sec (gal/sec)	6.7 (1.77)
Energy to coolant and oil; kWt	147.7
Energy to ambient; kWt	42.8
Energy to charge cooler; kWt	59.4
Air filter	Paper element

## Lubrication System

Oil capacity; L (gal)	40 (10.6)
Oil cooler	Water cooled
Oil filter	Spin on, replaceable
Oil temp (continuous operation); °C	113
Oil flow; L/min	172
Oil consumption @ full load (as a % of fuel consumption)	0.1

## Alternator Data

Manufacturer	<b>Stamford</b>	
Model	<b>HCI434E</b>	
Design	4 Pole, drip proof rotating field	
Exciter type	Brushless, self excited P.M.G. option is available	
Stator	2/3 winding pitch	
Rotor	Single bearing, flexible disc	
Leads	12	
Efficiency		
480V	93.7	
208V	93.4	
Voltage regulator	Solid state, Volts/Hz	
Voltage regulation		
Self excited	1%	
PMG	0.5%	
Insulation	Class H	
Protection	IP23	
Temp. rise @ 40°C ambient	125°C Prime 150°C Standby	
Alternator Cooling	Direct drive centrifugal blower	
Cooling air; m <sup>3</sup> /min	0.8	
Waveform distortion	No load < 1.5% Non-distorting balanced linear load < 5%	
Max. over-speed; rev/min	2250	
Telephone influence factor (TIF)	< 50	
Telephone harmonic factor (THF)	< 2%	
Sustained short circuit current 10sec; (amp)		
Star (WYE)	1600	
Parallel Star (Low WYE)	3200	

## Locked rotor kVA (skVA) @30% voltage dip

	Self Excited	PMG Excited
480/277V - 3ph	920	1050
208/120V - 3ph	680	820

## Control System



**DSE7320** is an advanced control system, suitable for a wide variety of single, diesel or gas, gen-set applications. Monitoring and an extensive number of engine parameters, the module displays warnings, shutdowns and engine status information on the back lit LCD screen, illuminated LEDs, remote PC and via SMS text alerts (with external modem).

- UL recognized, NFPA110 Level 1 compatible
- LCD text display, key menu navigation and front panel editing
- Off/Manual/Auto model switch
- Two wire starting/stopping in Auto mode
- Engine exerciser
- IP65 front panel rating with supplied sealing gasket
- Configurable 9 inputs, 8 outputs with expansion capability
- Real time clock provides accurate event logging
- Fully configurable via DSE Configuration Suite PC software
- Remote SCADA monitoring and BMS integration features
- License free PC software

## Protections

- Gen. Voltage - under/over
- Gen. Frequency - under/over
- Engine Speed - under/over
- Engine Oil pressure - low
- Engine Temp. - low/high
- Battery Voltage - low/high
- Weak battery
- Fail to start/stop
- Charge fail
- Over current & load(kW/kVAr)
- Unbalanced load
- Independent Earth Fault
- Reverse Power
- Fuel level - low/high (optional)
- Loss of speed signal

## Instruments

- Gen. Voltage (L-L/L-N)
- Gen Frequency
- Engine Speed
- Oil Pressure
- Water Temperature
- Battery Voltage
- Run time
- Engine maintenance due
- Phase sequence
- Pwr. monitoring (kWh / kVAh / kVArh)
- Power (kW/kVA/kVAr)
- Power factor
- Gen. Current (L1-L2-L3)
- Earth current

## Standard Features & Accessories

- UL2200 Listing
- Sound Attenuated Steel Enclosure
- 150mph Wind Rating
- Heavy Duty Steel Base-frame
- Anti-vibration pads
- Residential Grade Silencer Inside Enclosure
- Flex Fuel Lines
- Oil Drain Valve & Extension
- Emergency Stop Switch
- Battery, Battery Rack & Cables
- Battery Charger (2.5 Amp)
- Main Line CB (80% rated)
- Jacket Water Heater (3000W)
- Operations Manual
- 2 Years / 2000hours Limited Warranty

## Optional Accessories

- Upsized Alternator
- PMG Excitation
- Alternator Anti-condensation Heater
- Manual Speed Adjust
- Sub Base Fuel Tank (UL142 / UL2085)
- Low Fuel & Fuel Leak Alarms
- Fuel Level Monitoring on Controller & High Fuel Alarm
- Spring Type Anti-vibration pads
- Critical Grade Silencer
- Fuel Line Check Valve
- Oil Temperature Gauge
- Remote Emergency Stop Switch
- Battery Restraint
- Battery Charger 10/20Amp per NFPA110
- Main Line CB (100% rated)
- Main Line CB Shunt Trip
- Remote Serial Display Panel
- Remote Annunciation Panel (8/16/24 lights)
- 5 Years / 2000hours Limited Warranty

### Dimensions & Weight & Sound Level

#### Gen-set Without Fuel

	Open Type	Enclosed Type	
		Level 1	Level 2
L (in.)	158	205	205
W (in.)	75	75	75
H (in.)	78	88	109
Weight (lb)	6200	8500	9250
Sound Level (dBA@23ft)		77	75

#### Fuel Tank – UL142

	24h(665gal)	48h(1200gal)	72h(2000gal)
L (in.)	225	225	225
W (in.)	75	75	75
H (in.)	15	26	36
Weight (lb)	2800	3550	4250

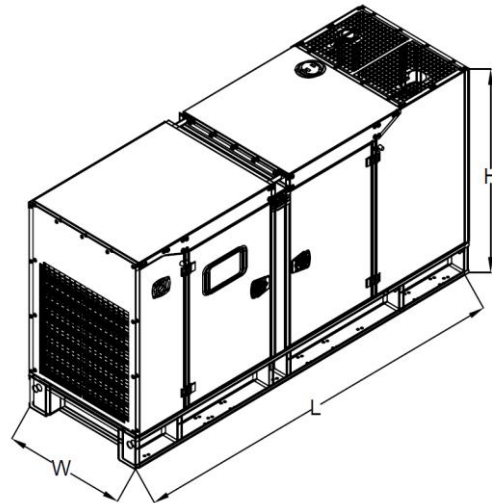

\*Manufacturer reserves the right to make changes in model, technical specifications, color, equipment and accessories without prior notice.



**AKSA POWER GENERATION USA LLC**  
 371 Exchange Street, West Monroe, LA 71292  
 Tel: 318.855.8377  
 Fax: 318.855.8381  
 E-mail: sales@aksausa.com  
 Aksa Power Generation USA is a member of

