

VECTOR DYNAMICS FOUNDATION SYSTEM WIND ZONE 1, 2, & 3 INSTALLATION DESIGN INSTRUCTIONS



Release Date 5/8/2001

INDEX

SECTION	PAGE NUMBER
INTRODUCTION	2
PIER HEIGHTS	3
GENERAL INSTALLATION	4
SET-UP INSTRUCTIONS 5 & 5a	
METAL PIER & V-DRIVE 6	
PARTS LIST	7 & 7a
CONCRETE INSTALLATION	8 & 9
SCHEMATICS	
WIND ZONE I	
- SINGLE SECTION	10
- SINGLE V-DRIVE	11
- METAL PIER	12
- DOUBLE SECTION	13
- TRIPLE SECTION	14
WIND ZONE II	
- SINGLE SECTION	15
- DOUBLE SECTION	16
- TRIPLE SECTION	17
WIND ZONE III	
- SINGLE SECTION	18
- DOUBLE SECTION	19
- TRIPLE SECTION	20
SOIL CLASSIFICATION	21
COMPONENT PARTS AVAILABLE UPON REQUEST	

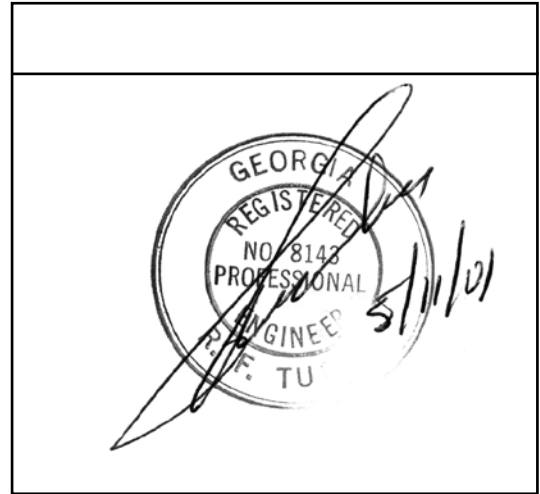

3220 E. 59th Street
Long Beach, CA 90805
PH: (562) 272-7231
FX: (562) 529-7513

DESIGN LISTING
#101

For Further Information

TIE DOWN ENGINEERING
5901 Wheaton Drive
Atlanta, GA 30336
404-344-0000
FAX 404-349-0401
www.tiedown.com

Tie Down Engineering, Inc.
VECTOR DYNAMICS INSTALLATION INSTRUCTIONS

Introduction

These instructions describe the proper use of the Vector Dynamics Foundation System in Wind Zones 1, 2, & 3. Additional installation instruction is available in VHS video, from manufactured housing distributors or from Tie Down Engineering, titled, Vector Dynamics Installation Video.

The Vector Dynamics foundation system supports the home by anchoring the two longitudinal main rails. The system is approved in Wind Zone I & II & III areas of the Manufactured Home Construction and Safety Standards and Wind Standards; Final Rule 24CFR part 3280 for both single and double section homes. Instructions for Class 5, Sub Soil Conditions, (Wind Zone I & II), are available through local distributors of Vector Dynamics or directly from Tie Down Engineering.

General

The Vector Dynamics Foundation System provides the support to resist lateral and over-turning movement of the home as required by the Federal Manufactured Home Construction and Safety Standards in Wind Zones I, II, & III when the system is used as described in these instructions. The following characteristics apply to both single and double section homes:

- Main rail minimum spacing of 86 inches or greater.
- Nominal 8 foot or less top plate height at side walls.
- Main rail depth of 12 inches or less.
- Maximum roof slope of 20 degrees (4.4 in. in 12 in.)
- Maximum pier height under main rail less than or equal to 56 inches (see page 3).

WIND ZONE I

- Maximum single section home width is 16 feet including eaves; maximum eave width of 12 inches on each longitudinal side of home.
- Maximum double section home width is 36 feet including eaves; maximum eave width of 12 inches on each longitudinal side of home.
- Maximum triple section home width is 48 feet including eaves; maximum eave width of 12 inches on each longitudinal side of home.

WIND ZONE II & III

- Maximum single section home width is 15 ft. including eaves, maximum eave width is 6" per side.
- Maximum single section home width of 16 ft. including eaves must use two additional vertical ties/anchors/stabilizer plates (one per side) as listed in the charts on page 15.
- Maximum double section home width including eaves 32 ft., maximum 12" eaves per side
- Maximum triple section home width including eaves 48 ft., maximum 12" eaves per side

The Vector Dynamics Foundation Systems may be used as a part of the vertical or gravity support system considering that each set of Vector Dynamic pad (s) has two (2) or three (3) square feet bearing area. Piers not used as part of the Vector system shall be located and constructed in accordance with the home installation instructions and/or state standards.

To inquire about the use of the Vector Dynamics Foundation Systems with homes of four or more sections or on homes requiring pier heights greater than 56 inches which are not included in these instructions, contact Tie Down Engineering, Inc. at 800-241-1806.

The Vector Dynamics Foundation Systems may be used on homes which require pier heights not to exceed 56 inches under one or both main rail(s). See page 3. Note that a ground anchor is used at each Vector system location in Wind Zones II & III. The use of interlocked double stacks of concrete blocks may be required by the home manufacturer or your state. Check with the most recent regulations in your state.

The Vector Dynamics Foundation System has not been designed for use on exposure "D" homes. Exposure "D" homes are homes located within 1500 feet of the coastline.

Additional vertical anchor ties that are unique to a home's design may be required by the home manufacturer. These locations include shear walls, marriage line ridge beam support posts, end frame ties and rim plates. The term end frame ties refers to the longitudinal ties that are attached to a home to resist wind load on the end walls. If longitudinal ties are required by the home installation instructions or other state standards, these longitudinal ties must be installed and connected to anchors that are independent of other ties and anchors. See separate instructions for the use of Vector Dynamics with Tie Down's Longitudinal Stabilization Device. The term rim plates refers to the factory brackets fastened onto the perimeter joist or specified as a location for vertical ties.

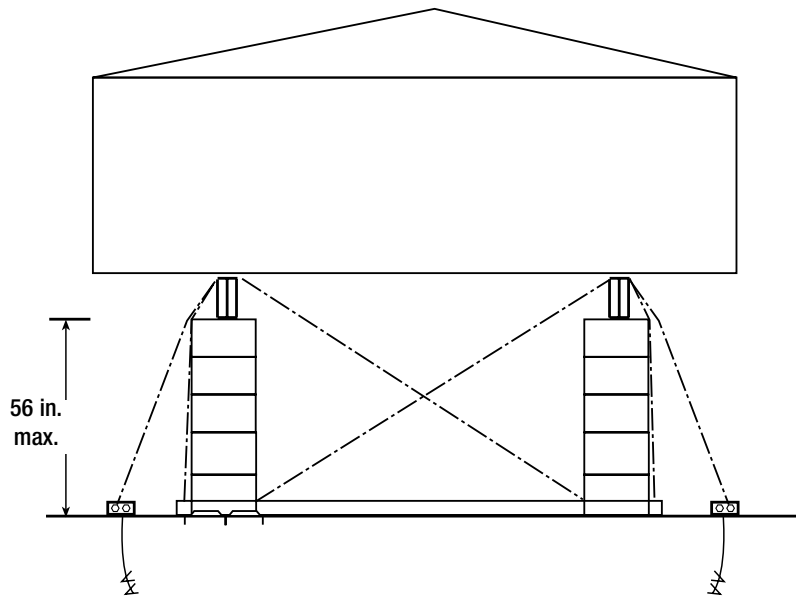

Figure 1

Maximum Pier Height (Wind Zones I & II only)

The Vector Dynamics Foundation System may be used on homes which require pier heights not to exceed 56 inches under one or both main rail(s). Note that a ground anchor must be used at each side of a Vector system location in Wind Zone II, and where the pier heights exceed 24 inches in Wind Zone I. Piers must be constructed in accordance with the manufacturer's installation instructions and/or state requirements. The use of interlocked double stacks of concrete blocks may be required by the home manufacturer or state. Check with the most recent regulations in your state.

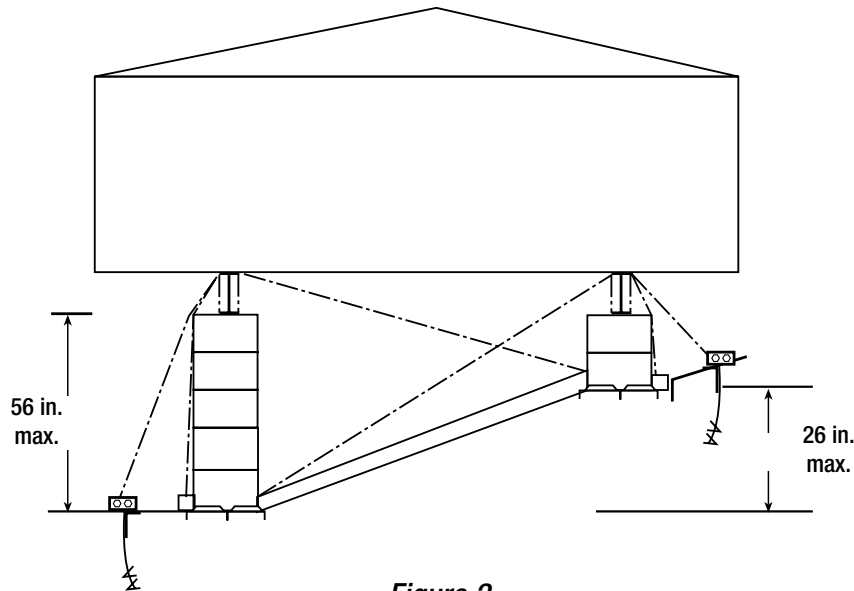

Figure 2

Unequal Pier Heights (Wind Zones I & II only)

Vector Dynamics may be used on homes with unequal pier heights of 56" or less under one or both main rails. The difference between the taller pier and the shorter pier cannot exceed 26". Note that a ground anchor must be used at each side of a Vector system installation in Wind Zone II, or in Wind Zone I where either of the pier heights in that location exceeds 24 inches. Only concrete blocks and pressure treated lumber compression members are permitted on unequal pier heights using the Vector system. Piers must be constructed in accordance with the manufacturer's installation instructions and/or state requirements. The use of interlocked double stacks of concrete blocks may be required by the home manufacturer or state. Check with the most recent regulations in your state.

GENERAL INSTALLATION INSTRUCTIONS

SITE PREPARATION

It is necessary that the home site be properly graded and sloped to prevent water and moisture from standing or flowing beneath the home. See manufacturer's home installation manual and state requirements for grading and other site preparation.

FOOTINGS AND FROST LINES

The Vector Dynamics Foundation System can be placed directly on top of the ground after clearing all loose vegetation. In areas where frost line/poured footers are required, the Vector system for concrete is used. See pages 8 & 9.

FOUNDATION/FOOTING SPECIFICATIONS FOR VECTOR PADS

Vector Pads must be used in place of conventional foundation pads for each Vector foundation system. Each (set of) Vector Pad(s) provides two or three square feet of pier bearing support. Vector Systems should be spaced as evenly as possible along the length of the home, with one Vector system within two feet of each end of the home. For pier locations in between the Vector Systems, use the foundation pads normally recommended by the home manufacturer and/or state requirements. Pier heights in excess of 24 inches or when unequal must follow instructions printed on page 3 of these instructions. Nominal 3-1/2 inch or 4 inch Schedule 40 PVC pipe or TDE steel compression strut (#59043) may be used only when the pier heights are similar on fairly level ground. Steel strut and PVC are not permitted when metal pier foundations are used. The adjustable galvanized steel compression strut, #59043, is attached to each inside pad with a 1/2" X 2-1/2" grade 5 carriage bolt and can only be used with the swivel connector on strap. The grade 5 bolt attaches the swivel connector and the steel strut to the pad. When the swivel connector is used with a wooden or pipe compressive member, the vector diagonal connector should be part #59279 not #59276. After tightening the end grade 5 bolts, adjustment bolt is installed through the two square steel compression struts to lock them in place. Foundation pad size and pier spacing must be consistent with home manufacturers' instructions and/or state requirements.

LUMBER/MOISTURE - TERMITE SHIELD

To cut lumber (2 - 2x4's or 1 - 4x4 per Vector system) for the center compression section, when using concrete blocks for piers, measure center to center frame (I-beam) distance and subtract 16". When using METAL PIER STANDS, measure center to center frame distance and add 16". 3-1/2" or 4" nominal schedule 40 PVC pipe meeting ASTM D1784 or Tie Down's steel compression strut (#59043) may be substituted for lumber as the center compression strut under certain conditions described above. Pipe adapter bracket, part #59281 must be used with PVC pipe simultaneously with the Inside Tie Brackets, part number 59276. The pipe adapter bracket is used on top of the pipe and under the Inside Tie Bracket. In certain regions the optional Moisture Termite Shield may be required between the lumber and ground.

ALL WOOD MUST BE PRESSURE TREATED, GROUND CONTACT RATED.

Tip: Pre-cut your lumber and mark as to brand or model of homes you will be installing. If frame widths are the same, the pre-cut boards will also be the same length in each Vector set-up.

STRAP TENSION

All strapping must be tight upon assembly of the Vector system. Tests have been conducted with "hand tightened" strap in the Vector system to remove the need for specific tension specifications. Hand tight is defined as removing all slack with minimum of movement available when pressing on the strap. While subsequent tightening of the straps is not required, straps should be checked after any strong wind conditions, just as conventional anchor tie down straps should also be checked, to insure the maximum performance of the foundation system. A minimum of two factory 1/4" spot welds must be used when straps are connected to the swivel connectors with welds.

Set-Up Instructions for the Vector Dynamics Foundation System #59007

1. SET VECTOR FOUNDATION PADS

Clear all loose vegetation from the immediate area where your Vector foundation pads will rest. Press or hammer pads into the ground.
Tip: Place a 3/8" nut on each U-bolt to keep it in place while you position the Vector pads.

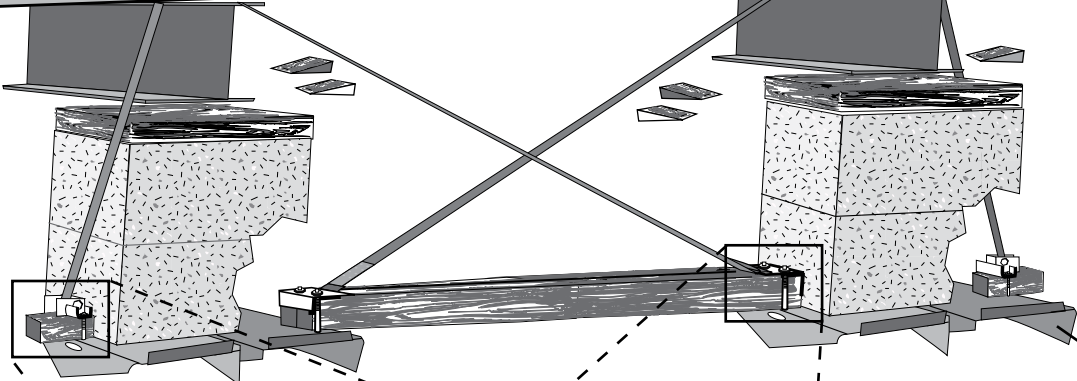
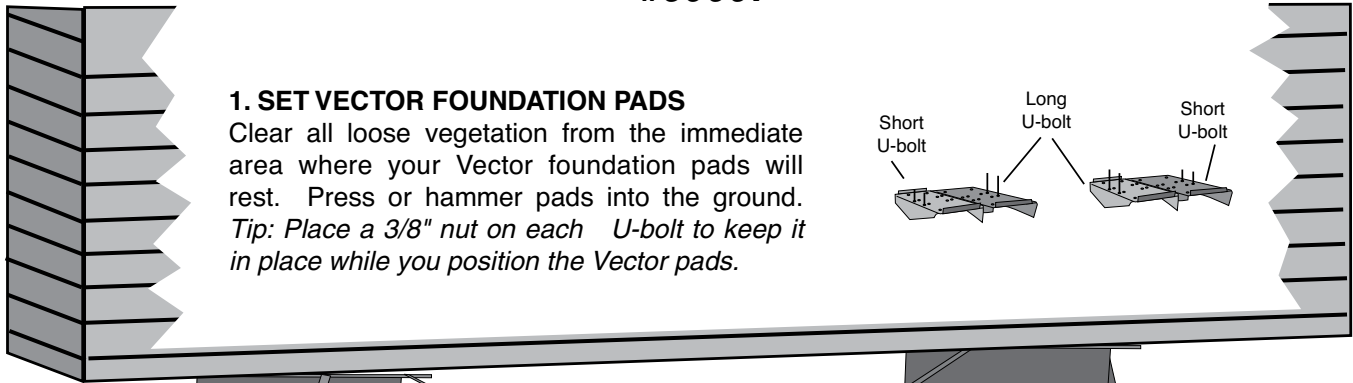
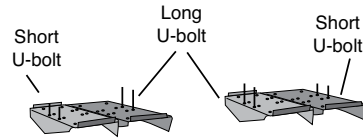

2 square foot pad placement or (1) 3 square foot pad

2. SET BLOCKS (OR PIERS) ON VECTOR FOUNDATION PADS

Center the foundation blocks over the Vector pads. Place the pre-cut 4x4, 2x4's (side by side), Schedule 40 PVC (w/PVC adapter plate, part #59281) or 1 adjustable TDE steel compression member, (part #59043) tightly between the blocks, with ends resting on the Vector pads, and centered on each U-bolt.

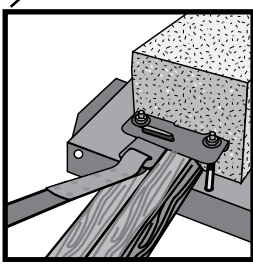
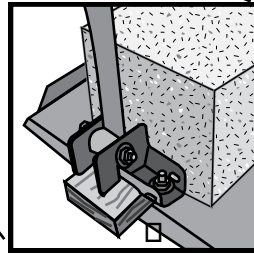

3. OUTSIDE TENSION BRACKETS

Attach an Outside Tension Bracket to the U-bolts on the outside of the foundation blocks and Vector pads. Place one of the short 6"- 2x4's between the bracket and Vector pad. Adjust the short 2x4 so that it pushes against the foundation blocks, removing any space between the piers and center compression section. Tighten the 3/8" bolts.

4. INSIDE BRACKETS AND STRAPS

Attach the Inside Tie Brackets to the U-bolts over the pre-cut boards or PVC. Attach a strap with hook to each inside tie bracket. Tighten bracket. When using looped strap and a crimp seal, in place of the hook, place a 3" long section of strap, folded in half and inserted between the strap and inside tie bracket. Place other end of strap over the opposite I-beam and continue down to outside of the foundation blocks. Attach the strap to the Outside Tension brackets using the slotted bolt and nut provided. Wind strap a minimum of five times around the bolt. Continue tightening the slotted bolt until all slack has been removed and the strap is tight.

5. SET ANCHORS

Refer to section home drawings for anchor installation information. Stabilizer plates are required for diagonal ties only. Preload anchor against stabilizer plate. Make certain all slack is removed and strap is tight. For single section homes in rocky soil conditions in Wind Zone 1 only (Soil Classifications 2 & 3 only), use minimum of 3 each V-Drive anchors per side. See drawing on page 5 for placement.

Set-Up Instructions for Vector System #59018

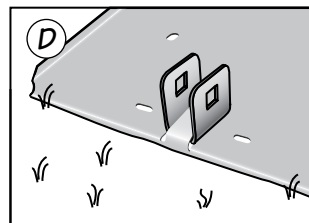
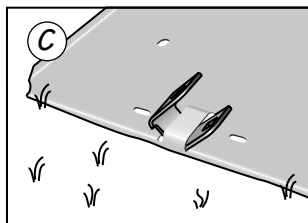
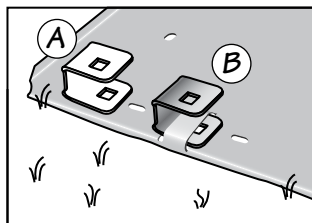
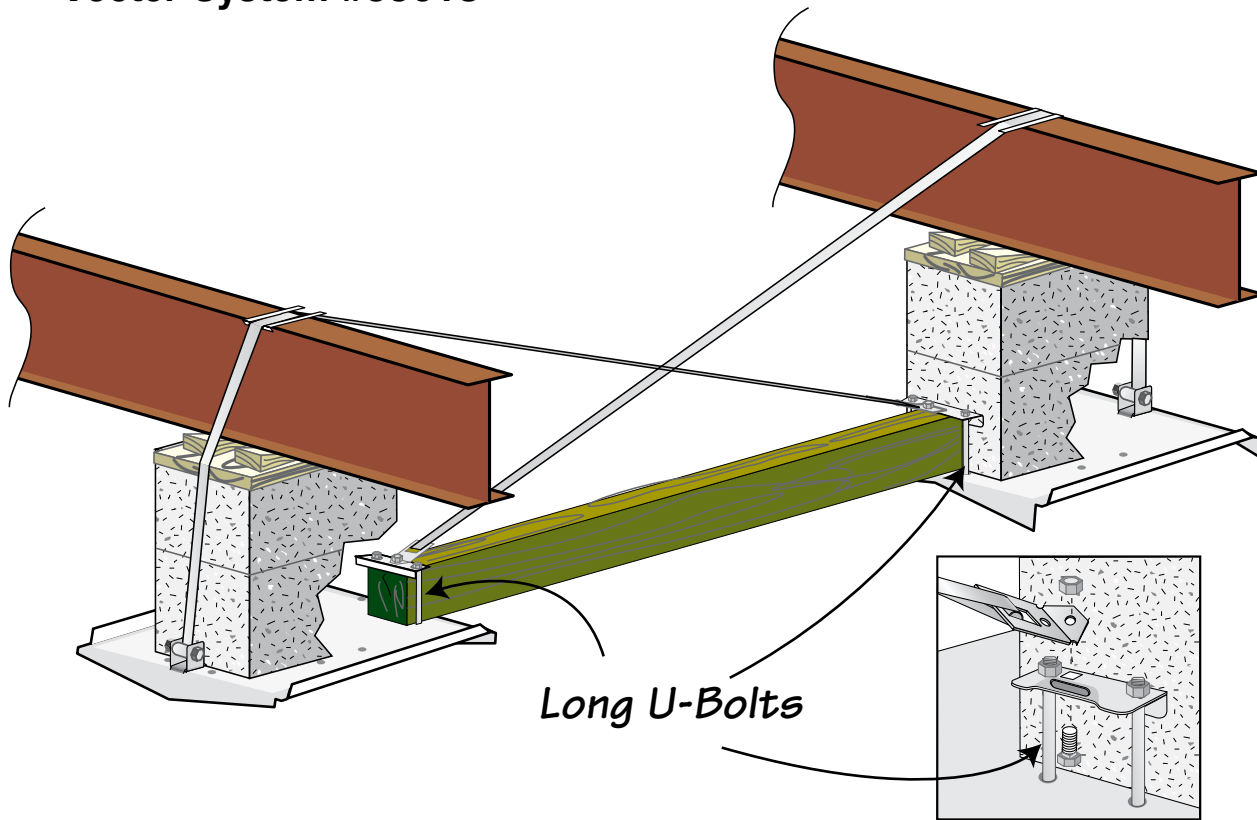

1. Set Vector Pads

Clear all vegetation where pads will rest. Place a long U-bolt in pad as shown. Press or hammer pad into the ground.

2. Set Block or piers on pads.

Center foundation blocks or piers on pads. Place pre-cut center compression member between blocks, resting on pads, centers between U-bolts as shown.

3. Outside Tension Bracket

Attach outside tension bracket as shown to outside of pads.

4. Inside brackets & straps

Attach the inside tie brackets to the U-bolts over the compression member. Attach a strap w/hook or swivel strap w/nut/washer & bolt (washers are required). Place other end of the strap over opposite I-beam & down to outside tension bracket. Cut strap 12 - 15 inches past bracket. Attach strap & slotted bolt in bracket. Tighten strap until tight with 4-5 wraps around bolt. Repeat with opposite strap.

Vector Dynamics

Metal Pier Installation

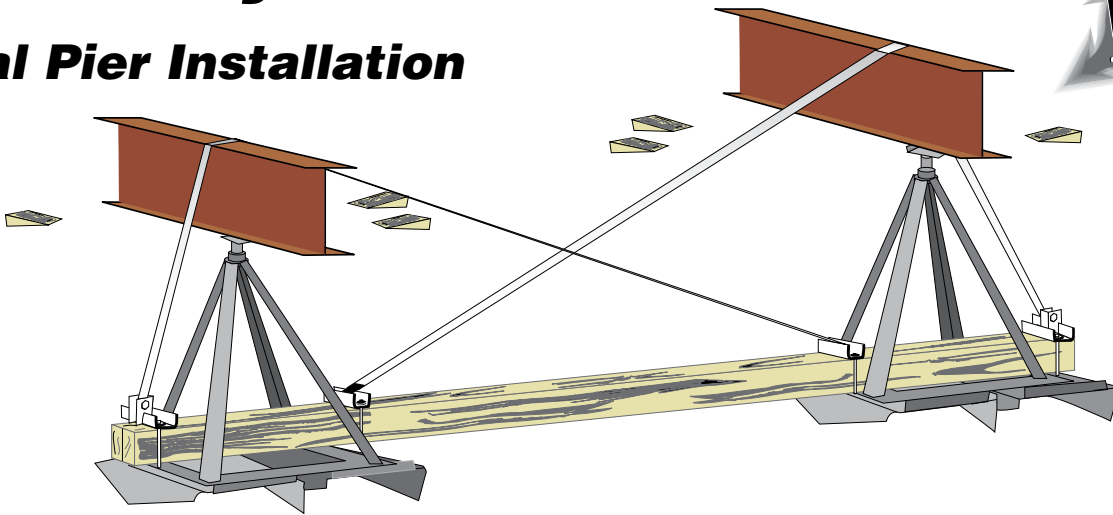

For metal piers, place the piers in the center of the Vector pads. Set the single 4x4 or two 2x4's through the piers, centered in the U-bolts, so that the board(s) overhangs the Vector pads on each side by about 2". Outside Tension brackets attach the same. Inside tie brackets mount "upside down" as shown in drawing. Metal piers using the Vector system can only be used on level ground installations.

Conventional pier adjusters must be placed under beam with upturned edge directed towards the outside of the home. Pier capacity rating and spacing must be consistent with home manufacturers' installation instructions and/or state requirements.

When using METAL PIER STANDS, cut lumber (2 - 2x4's or 1 - 4x4 per Vector system) for the center compression section, by measuring center to center frame distance and adding 16". Optional Moisture Termite Shield may be required in certain regions. ALL WOOD MUST BE PRESSURE TREATED, GROUND CONTACT RATED. Adjustable steel strut (#59043) and PVC Schedule 40 pipe are not permitted to be substituted for lumber when using metal pier stands.

V-Drive System Installation: for rocky soil conditions

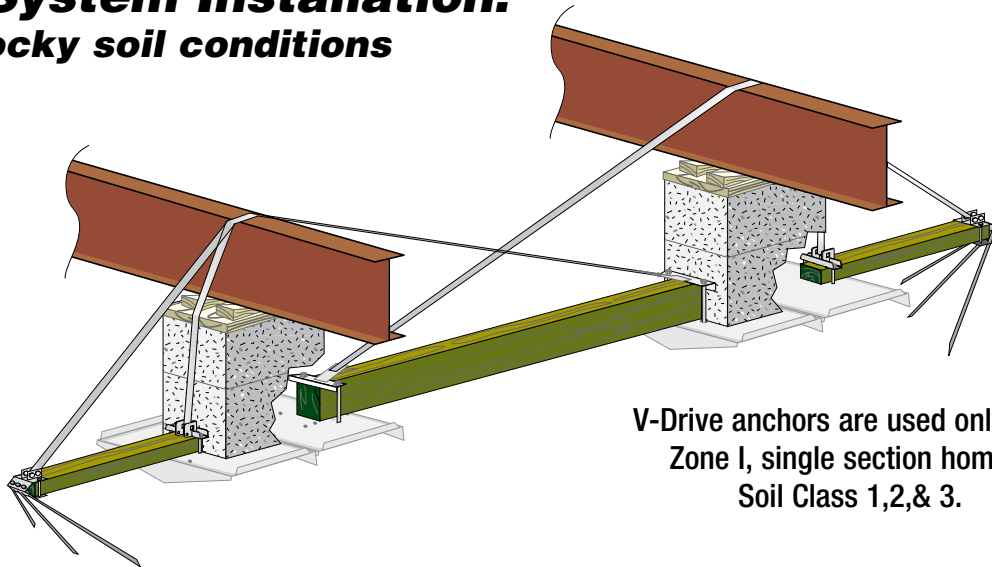

V-Drive anchors are used only with
Zone I, single section homes.
Soil Class 1,2,& 3.

V-Drive anchors are used only in Wind Zone I, on single section homes in areas where rocky soil conditions do not allow a conventional helix style anchor to be installed. For solid rock, Soil Class 1, predrilling of holes for the V-drive rods is recommended.

Vector Systems are set following the general set up instructions provided. With the V-Drive anchor, the short 2x4 boards used with the outside tension brackets are discarded. In place of the short 2x4's, a longer 2x4 is used as per the diagram above. This 2x4 board should extend from the base of the Vector pier set to 5 inches from the side wall of the home.

Place the V-Drive head over the end of the longer board. Using a heavy hammer or electric hammer gun, drive the three V-Drive anchor rods through the V-Drive heads at an angle of approximately 45 degrees under the home. The rods must come to a complete stop on the V-Drive head. Attach a strap with hook, buckle or beam clamp to the frame and attach to the V-Drive head with a slotted bolt. Cut the strap end about ten inches past the anchor head to allow at least five wraps around the slotted bolt. Continue tightening strap until all slack is out and strap is tight.

Vector Dynamics

Foundation Systems

Component Parts List

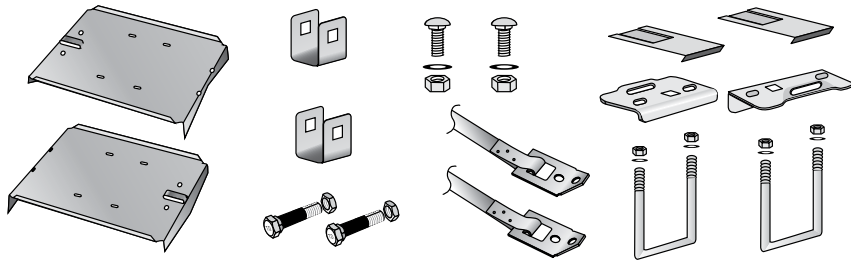

Vector System 2000
Part # 59018
Single piece pads with straps
and slotted bolts

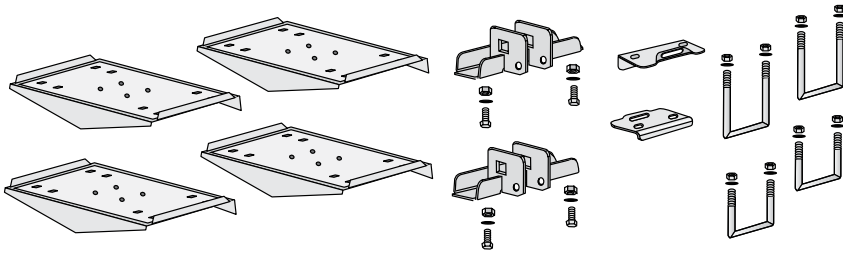

Vector System
Part # 59007

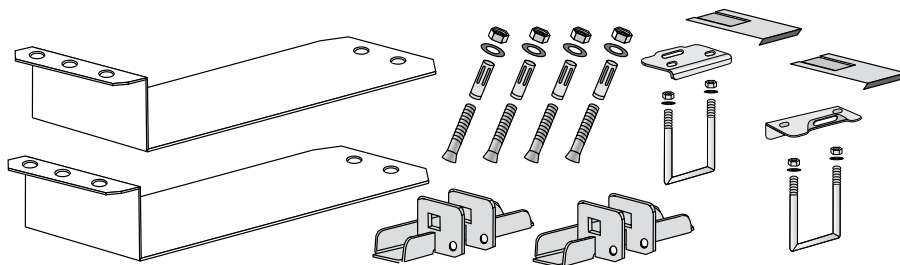

Concrete Vector System
Part # 59008
(for single stack blocks)

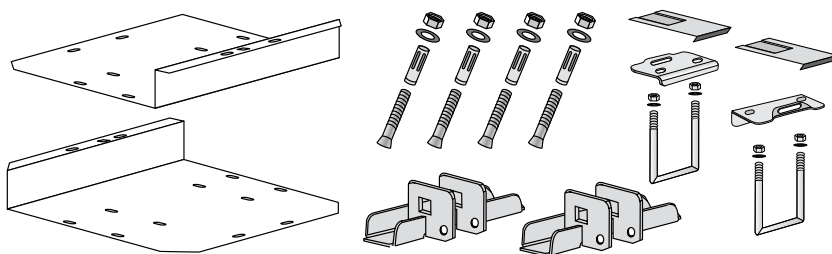

Concrete Vector System
Part # 59006
(for double stack blocks)

Vector Dynamics

Foundation Systems Component Parts List

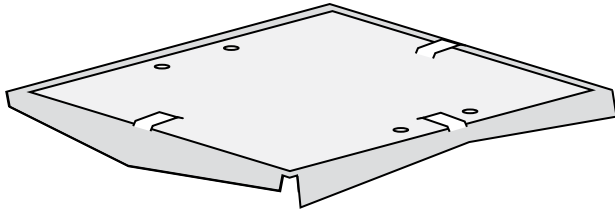

Vector 2000 3 Sq. Ft. Pad
 Part # 59271
 1 required with 59026 Longitudinal System
 2 required with 59024 Lateral System

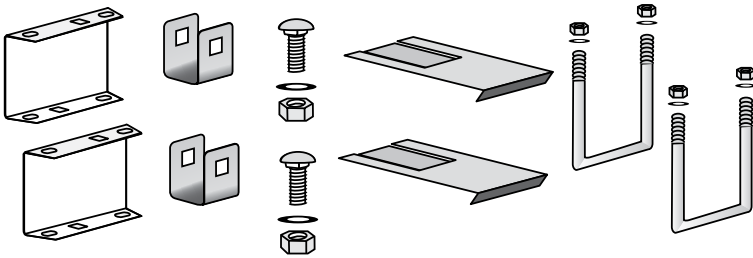

Vector Lateral Hardware Kit
 Part # 59024
 (for use with 59271)

Adjustable Steel
 Compression Strut
 P/N 59043

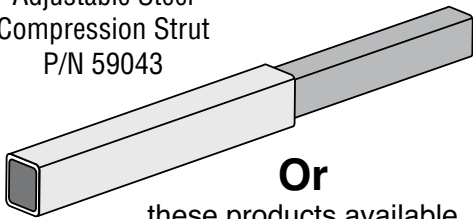

Or

these products available
 at your local hardware store

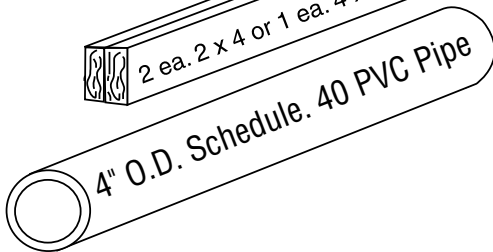
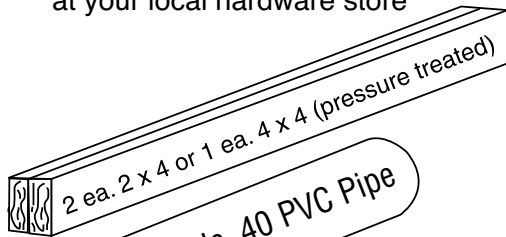

A. Schedule 40 PVC pipe: 3-1/2" or 4" nominal schedule 40 polyvinyl chloride pipe or conduit made from type 1, grade 1, with cell classification 12454 as defined in ASTM D1784. Compound dimensions and tolerances in accordance to the requirements of ASTM D1785D. Color can be gray or white. Outside diameter is 4 inches.

B. Ground Contact Rated Wood: No. 2 yellow pine or equivalent, pressure treated to AWPACI-1990 minimum, stamped "Ground Contact Rated" on wood or on label attached to the wood when purchased.

Vector Dynamics System for Concrete Applications

Instructions for Vector Kit #59008 (for single stack)

or Vector Kit #59006 (for double stack blocks)

Page 1 of 2



These instructions are an addendum to the standard Vector Dynamics instructions. Read and follow all applicable instructions and guidelines in the Vector instructions and home installation manual. The Vector system for concrete pads applies to concrete footers, runners and slabs. Minimum size of concrete per Vector pier is 24" x 24" x 4" (for part #59006 or 59008) or 18" round X 12" deep (for part # 59008 only). The bottom of footers must be below the frost line or a minimum of 4" below finished grade whichever is greater. Concrete must be a minimum of 2500 PSI and sufficiently cured and set to accommodate an anchor bolt to its' full load resistance.

1. Determine location of pier sets where the Vector systems will be located.
2. Place one Vector concrete pad (galv. metal) on the concrete where the pier will be located, centered under the I-beam of the home. Place the upturned edge towards the center of the home and directed to the opposite Vector pier. Do the same for the opposite Vector pier.
3. Measure the distance between the two Vector system pads at the base where the Vector pad meets the concrete. Cut two ground treated 2x4's this length and place between the piers as shown.
4. Place a long u-bolt under the 2x4's and through the holes of the Vector pad as shown.
5. Place the concrete pier blocks on the Vector pad. Center the blocks under the frame. The upturned edge end of the Vector pads should be up against the inside of the pier blocks.
6. Build vector piers but do not wedge at this time.
7. Using a concrete drill bit, drill two holes on each side into the concrete using the holes in the Vector pad as a guide. Drill the 3/8" diameter holes 3 inches deep.
8. Place an outside tension bracket on the Vector pad as shown in Illustration one. Line up the holes in the bracket, Vector pad and concrete pad.

Illustration One

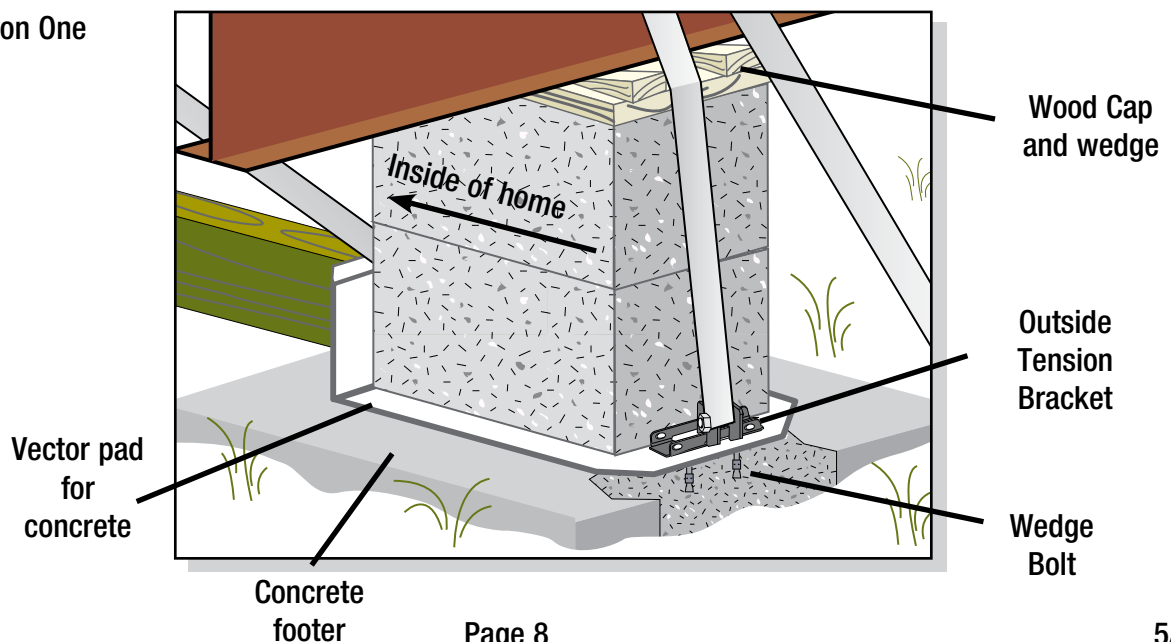

Vector Dynamics System for Concrete Applications

Instructions for Vector Kit #59008 (for single stack)

or Vector Kit #59006 (for double stack blocks)

Page 2 of 2



9. Put a washer and nut on one of the 3/8" x 3-3/4" wedge anchors provided. The nut should be screwed on enough to have 1 or 2 threads showing on the top of the bolt. Place the wedge end of the bolt into one of the holes, going through the outside tension bracket, metal Vector pad and into the concrete.
10. Using a hammer, tap the wedge bolt into the hole. Maximum height for expansion bolt above concrete is 2".
11. Repeat for the other hole in the outside tension bracket and the two holes on the other Vector system pier set.
12. Place an inside tie bracket over the u-bolt so that the lip of the bracket is between the Vector plate and concrete blocks. Place washers and nuts on each U-bolt. Do not tighten yet.
13. Attach a strap with hook or crimp seal to the inside tie bracket, with sufficient length to go over the opposite pier and down to the outside tension bracket, plus 12 inches for wrapping the slotted bolt. Repeat for the opposite side.
14. Tighten inside u-bolts at this time.
15. Use the outside tension brackets to remove any space between the outside tension brackets, concrete blocks and the inside edge of the Vector pad, by tapping the brackets with a hammer.
16. Wedge the pier set at this time.
17. Using a 9/16" socket wrench, tighten all of the wedge/anchor bolts, securing the outside tension bracket and Vector pad to the concrete.
18. Using a slotted bolt in the outside tension brackets, insert strap through slotted bolt with end of strap aligned with outside edge of bolt. Turn slotted bolt until straps are tight using at least five turns on the slotted bolts.

Illustration Two

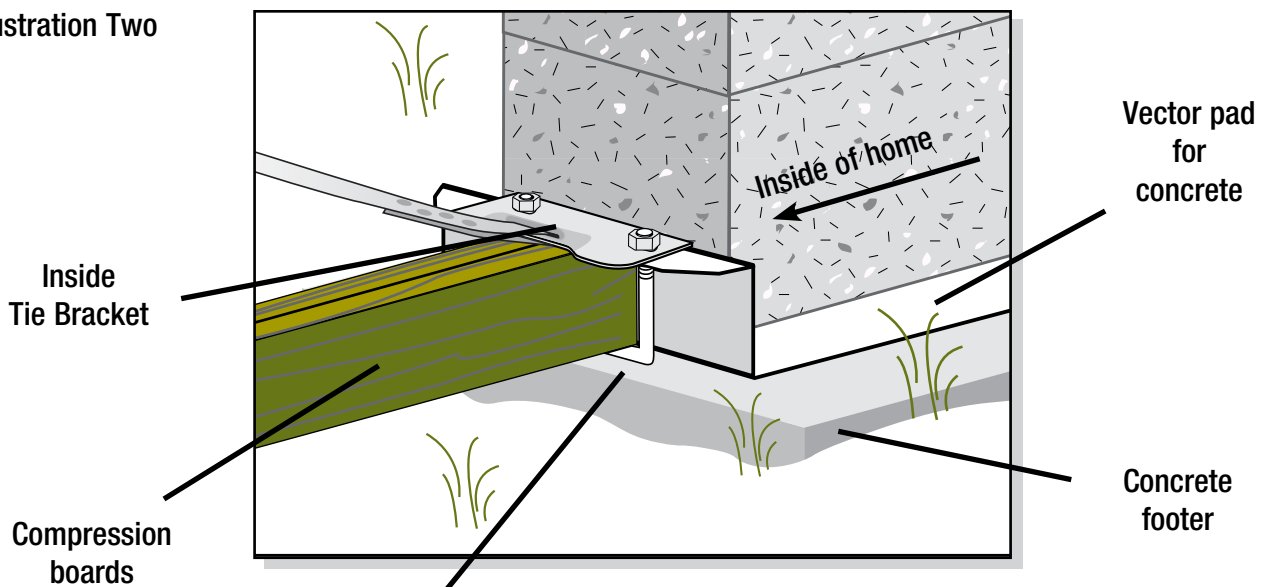

WIND ZONE I Vector Dynamics Systems Required for **Single Section Homes** (Materials Required)

Example of a 72 ft single section home
Illustration shows general spacing for vector systems.

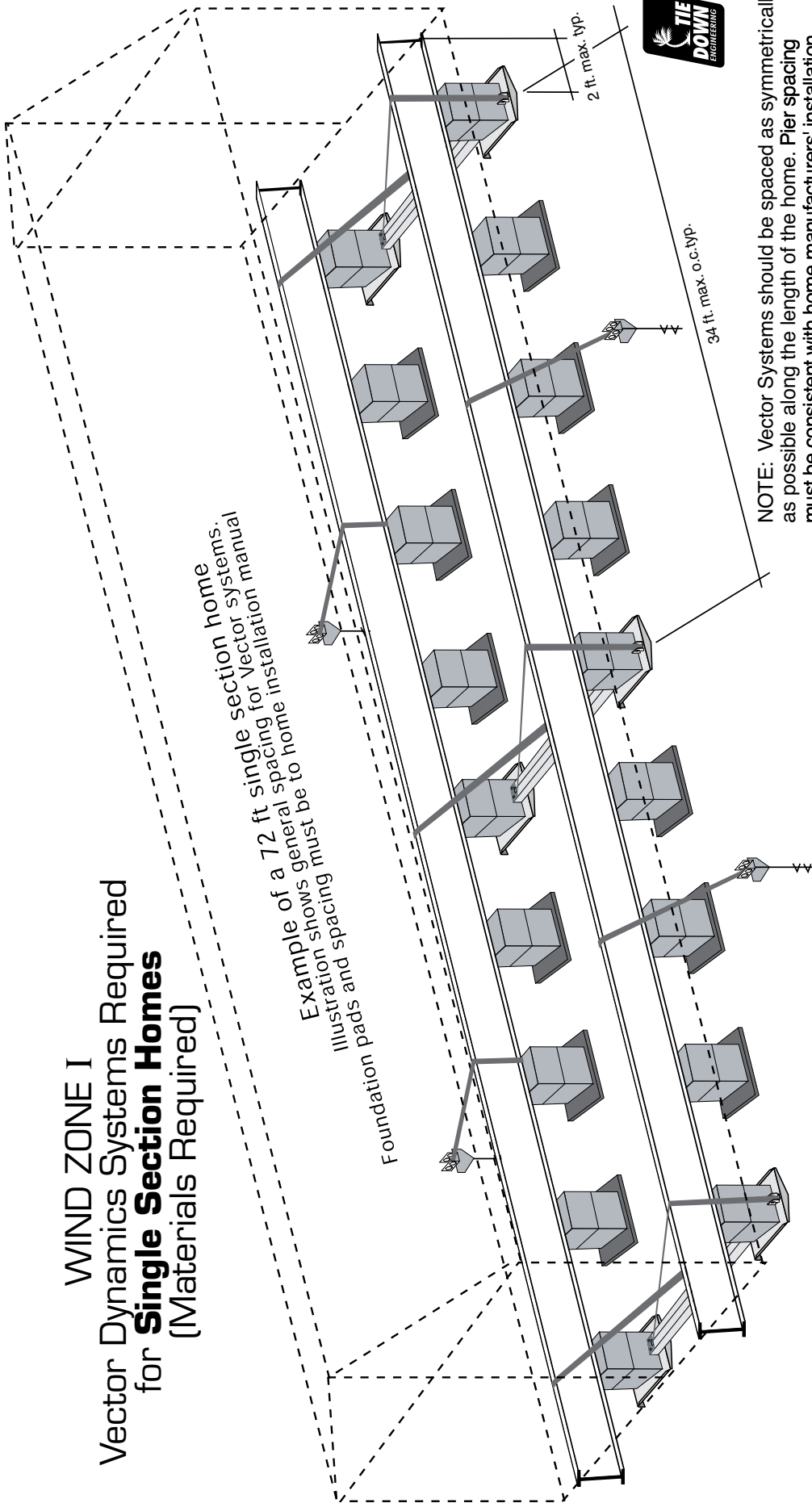

NOTE: Vector Systems should be spaced as symmetrically as possible along the length of the home. Pier spacing must be consistent with home manufacturers' installation instructions and/or state requirements.

Maximum allowable working drag load for the Vector System with the steel compression strut is 3,150 pounds per K2 Engineering test report.

Soil Classifications: 2, 3, 4A, & 4B
Soil Bearing Capacity: 1,000 PSF minimum
Anchors Required*: 30" with 4" helix anchor (59095), 12" stabilizer plates (55292), 1-1/4" frame ties w/4725 lbs. min. breaking strength.

Home Length	Vector Systems Required	Anchors Required Per Side *
0 to 72'	3	2
73' to 90'	4	3

* Anchor and stabilizer plate combination

- Each Vector Foundation System requires**
- One Vector Kit, 2 slotted bolts
 - 2 ea. 1-1/4 in. ties, length will vary with pier height (4725 lb. min. break),
 - 1 ea. 4 x 4 pressure treated wood compression member
 - or 2 ea. 2 x 4 pressure treated wood compression member
 - or 1 ea. 3-1/2" or 4" nominal SCH 40 PVC pipe compression member
 - or 1 TDE adjustable steel strut

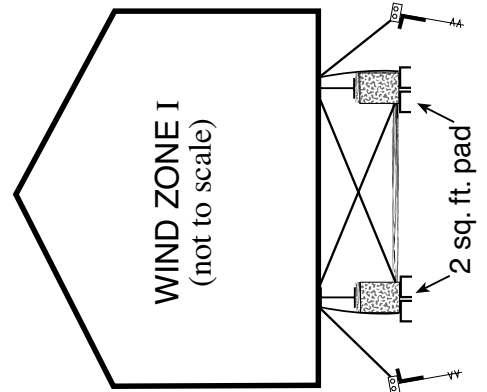

WIND ZONE I Vector Dynamics Systems Required Single Section Homes Difficult Soil Conditions

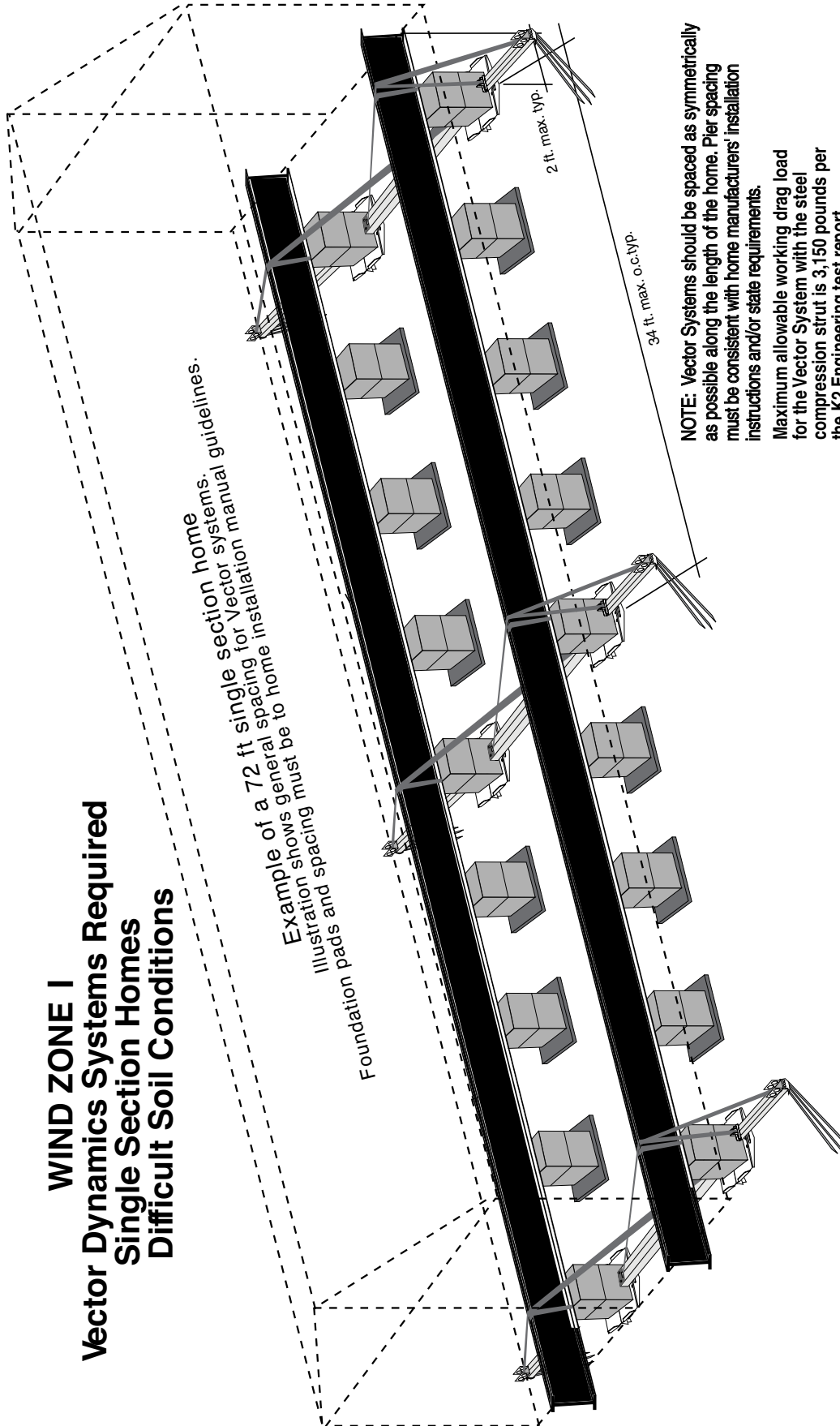

NOTE: Vector Systems should be spaced as symmetrically as possible along the length of the home. Pier spacing must be consistent with home manufacturers' installation instructions and/or state requirements.

Maximum allowable working drag load for the Vector System with the steel compression strut is 3,150 pounds per the K2 Engineering test report.

Soil Classifications: 2, 3,
Soil Bearing Capacity: 1,000 PSF minimum
Anchors Required*: "V" Drive Anchor, Part Number 59269
1-1/4" frame ties w/4725 lbs. min. breaking strength.

When using "V" Drive Anchors

Each Vector Foundation System requires

- One Vector Kit, 2 "V" Drive Anchors, 4 slotted bolts
- 2 ea. 1-1/4 in. tie, length will vary with pier height (4725 lb. min. break)
- 1 ea. 4 x 4 pressure treated wood compression member
- or 2 ea. 2 x 4 pressure treated wood compression member
- or 1 ea. 3-1/2" or 4" nominal SCH 40 PVC pipe compression member (center compression member only)
- or 1 TDE adjustable steel strut
- 2 ea. 2x4 pressure treated wood for "V" Drive Anchor connection.

Note: PVC pipe cannot be substituted for wood on the "V" Drive Anchor connections.

Home Length	Vector Systems Required	Anchors Required Per Side *
0 to 72'	3	3
73' to 90'	4	4

* "V" Drive Anchor, Part Number 59269

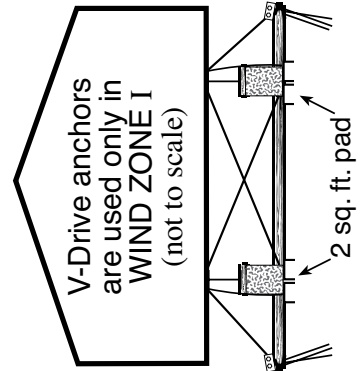

Metal Pier Sets ZONE I Vector Dynamics Systems Required for Single Section Homes Up to 72 ft. (Materials Required)

Example of a 72 ft single section home

Illustration shows general spacing for Vector systems.

Foundation pads and spacing must be to home installation manual guidelines.

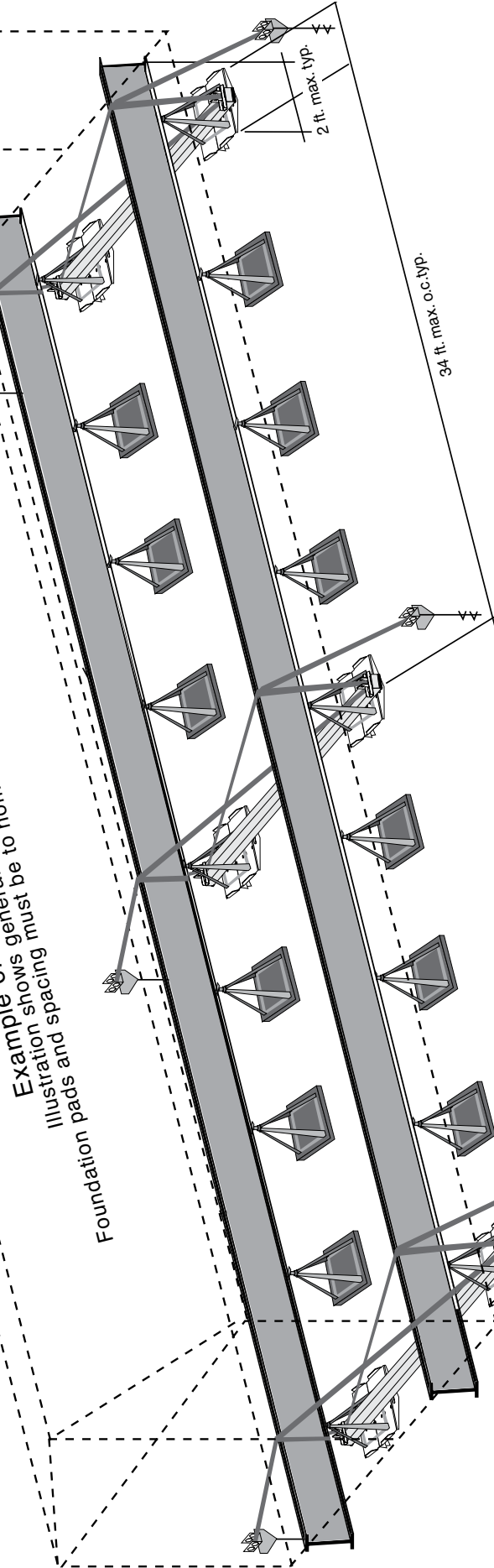

- Soil Classifications 2, 3, 4A, & B4
- Soil Bearing Capacity: 1,000 PSF minimum
- Anchor Requirements: 3/4" x 30" with 4" helix and 59095)
- Materials: Each Vector Foundation System requires one Vector Kit, 2 tie bolts, 2 ea. 1-1/4" x 2 ft. ties, 64 min. br 1 ea. 4 x 4 wood support member or 2 ea. 2 x 4 wood support member

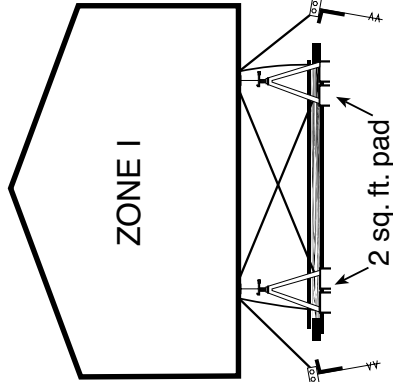

Home Length	Vector Systems Required	Anchors Required Per Side
0 to 72'	3	2
73' to 90'	4	3

* Anchor and stabilizer plate combination



NOTE: Vector Systems should be spaced as symmetrically as possible along the length of the home

WIND ZONE I Vector Dynamics Systems Required for Double Section Homes (Materials Required)

Example of a 72 ft double section home illustration shows general spacing for Vector Systems. Illustration must be to home installation manual guidelines.

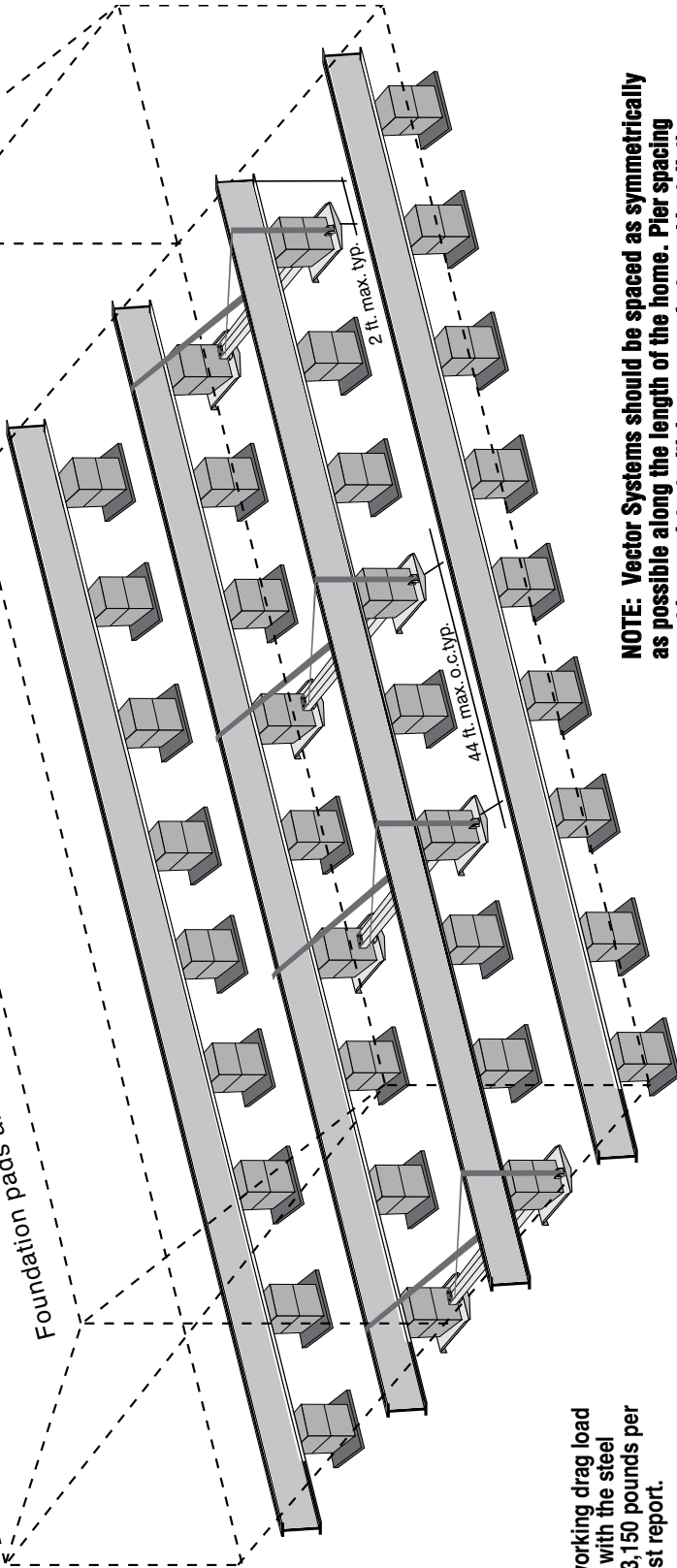

Maximum allowable working drag load for the Vector System with the steel compression strut is 3,150 pounds per the K2 Engineering test report.

NOTE: Vector Systems should be spaced as symmetrically as possible along the length of the home. Pier spacing must be consistent with home manufacturers' installation instructions and/or state requirements.

Soil Classifications: 2, 3, 4A, & 4B
Soil Bearing Capacity: 1,000 PSF minimum
Anchors Required: None (marriage wall anchors may be required by home manufacturer)

Home Length	Vector Systems Required
0 to 48'	2
48' to 71'	3
72' to 89'	4

Each Vector Foundation System requires

- One Vector Kit, 2 slotted bolts
- 2 ea. 1-1/4 in. ties, length will vary with pier height (4725 lb. min. break),
- 1 ea. 4 x 4 pressure treated wood compression member
- or 2 ea. 2 x 4 pressure treated wood compression member
- or 1 ea. 3-1/2" or 4" nominal SCH 40 PVC pipe compression member
- or 1 TDE adjustable steel strut

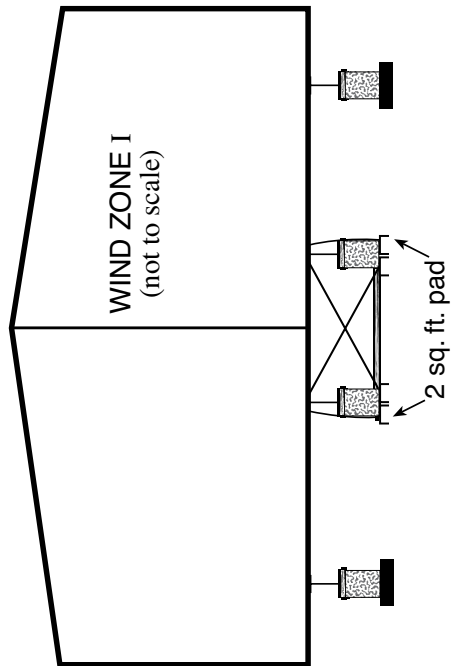

WIND ZONE 1 Vector Dynamics Systems Required for Multi Section Homes (Materials Required)

Soil Classifications: 2, 3, 4A, & 4B
Soil Bearing Capacity: 1,000 PSF minimum

Home Length	Vector Systems Required	Anchors Required Per Side
Homes up to 48'	2 Vector Foundation Systems	0
Homes over 48' up to 52'	3 Vector Foundation Systems	0
Homes over 52' up to 76'	4 Vector Foundation Systems	0

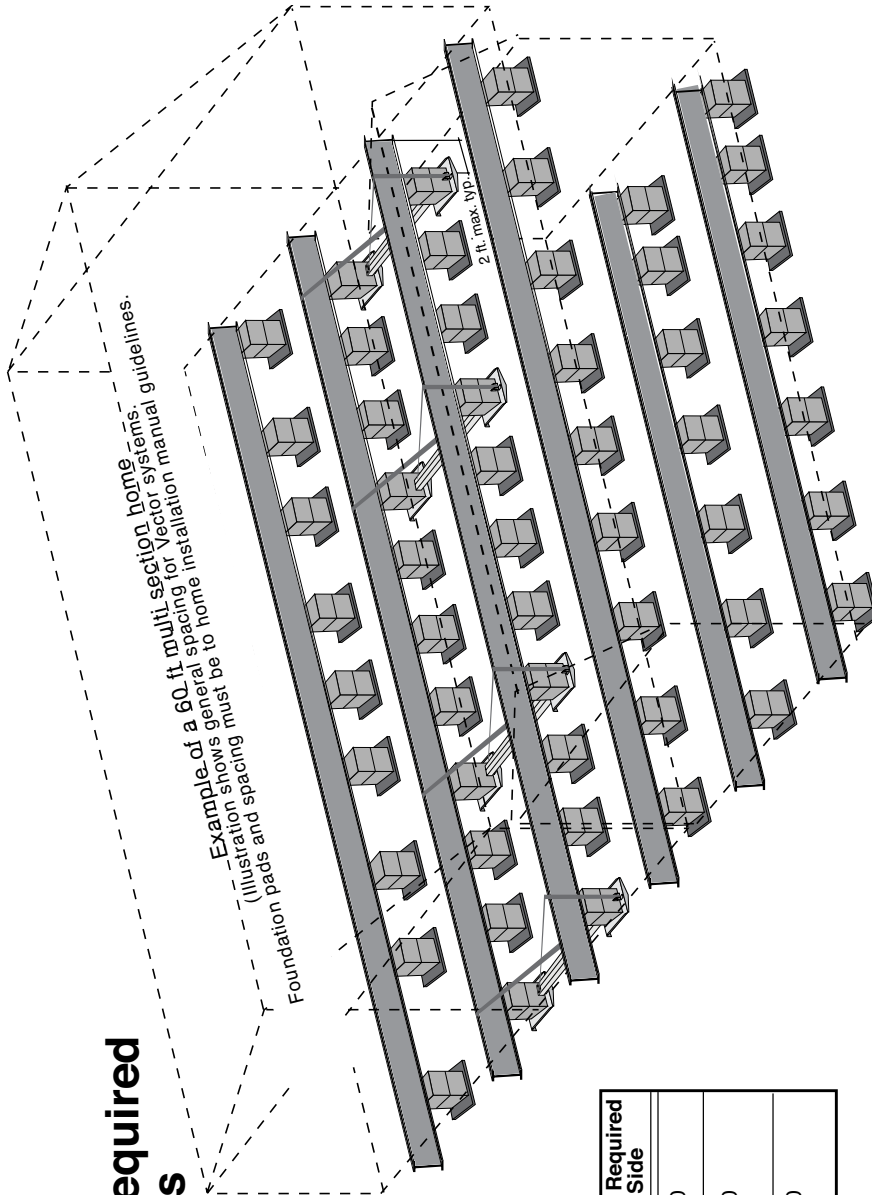

Example of a 60 ft multi section home (Illustration shows general spacing for Vector systems, installation manual guidelines. Foundation pads and spacing must be to home installation manual guidelines.)



Maximum allowable working drag load for the Vector System with the steel compression strut is 3,150 pounds per the K2 Engineering test report.

- Materials:
- Each Vector foundation system requires One Vector Kit
 - 2 ea. 1-1/4 in. ties (4725 lb. min. break)
 - 1 ea. 4 x 4 wood compression member or 2 ea. 2 x 4 wood compression member or 3-1/2" or 4" nominal SCH40 Pipe compression member or 1 TDE adjustable steel strut

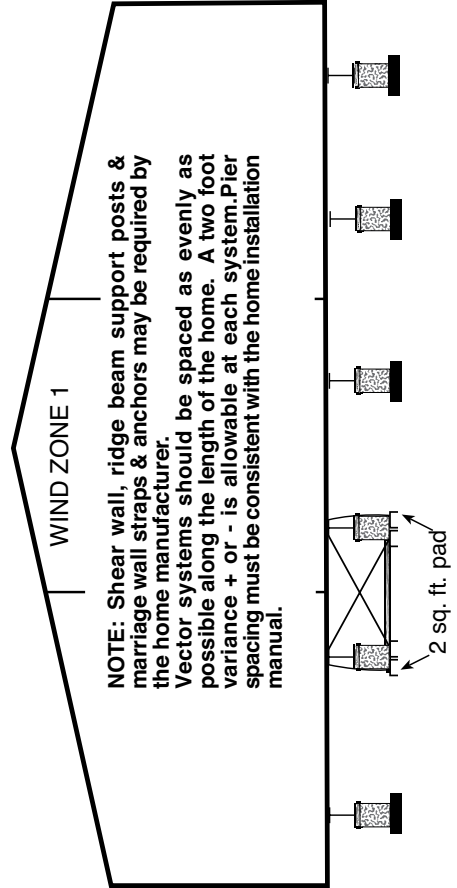

NOTE: Shear wall, ridge beam support posts & marriage wall straps & anchors may be required by the home manufacturer. Vector systems should be spaced as evenly as possible along the length of the home. A two foot variance + or - is allowable at each system. Pier spacing must be consistent with the home installation manual.

WIND ZONE II (Hurricane) Vector Dynamics Systems Required for Single Section Homes (Materials Required)

Example of a 72 ft single section home

Illustration shows general spacing for Vector systems.
Foundation pads and spacing must be to home installation manual guidelines.

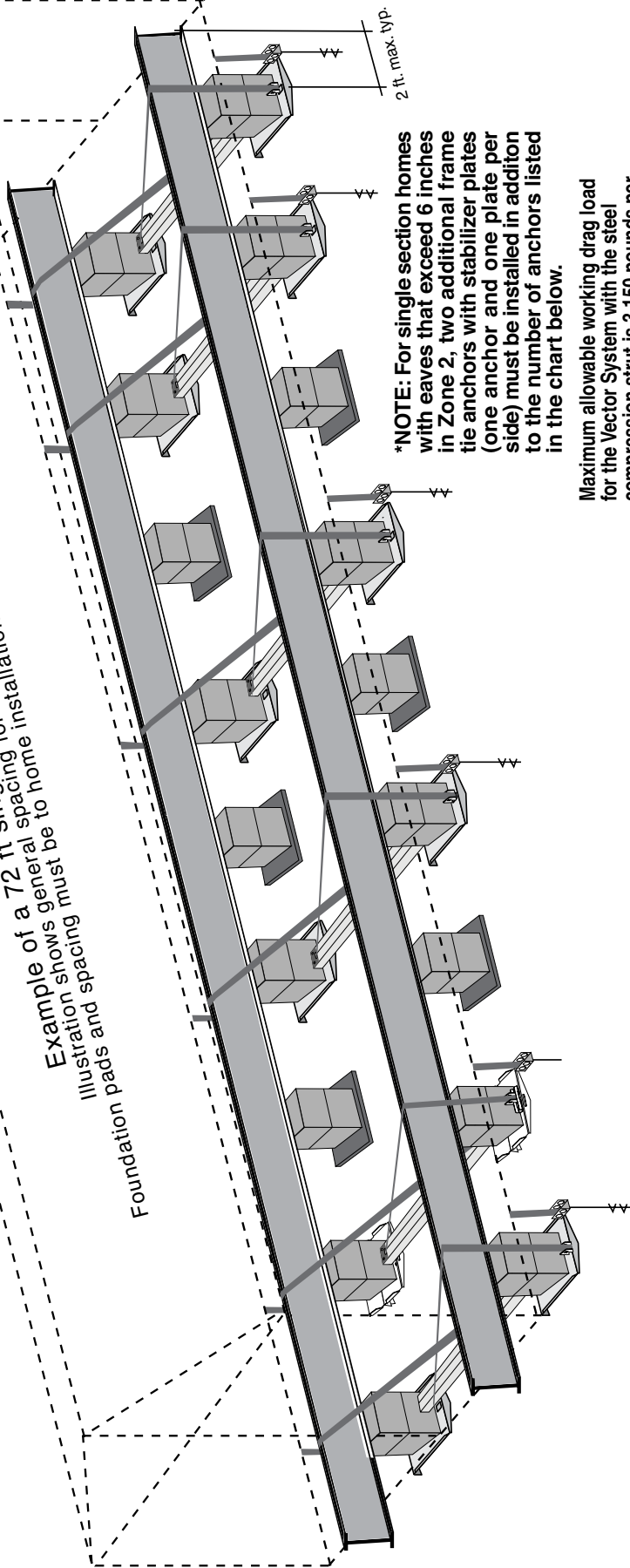

***NOTE:** For single section homes with eaves that exceed 6 inches in Zone 2, two additional frame tie anchors with stabilizer plates (one anchor and one plate per side) must be installed in addition to the number of anchors listed in the chart below.

Maximum allowable working drag load for the Vector System with the steel compression strut is 3,150 pounds per the K2 Engineering test report.

Soil Classifications: 2, 3, 4A, & 4B
Soil Bearing Capacity: 1,000 PSF minimum
Anchors Required*: 30" with 4" helix anchor (59095), 1-1/4" vertical ties w/4725 lbs. min. breaking strength.

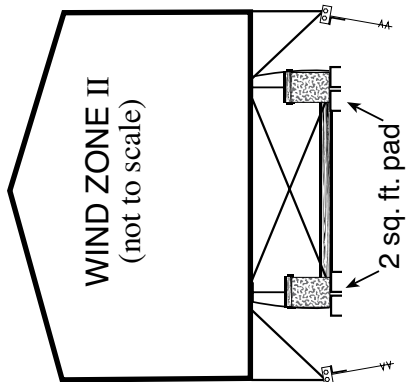

Home Length	Vector Systems Required	Anchors Required Per Side *	
		Eaves 6" or less	Eaves over 6" less than or equal to 12"
0 to 48'	4	4	5
49' to 60"	5	5	6
61' to 72'	6	6	7
73" to 84'	7	7	8
85' to 90'	8	8	9

Vector Systems should be spaced as symmetrically as possible along the length of the home. Pier spacing must be consistent with home manufacturers' instructions and/or state requirements.

Each Vector Foundation System requires

- One Vector Kit, 2 slotted bolts
- 2 ea. 1-1/4 in. ties, length will vary with pier height (4725 lb. min. break).
- 1 ea. 4 x 4 pressure treated wood compression member
- or 2 ea. 2 x 4 pressure treated wood compression member
- or 1 ea. 3-1/2" or 4" nominal SCH 40 PVC pipe compression member
- or 1 TDE adjustable steel Strut



WIND ZONE II Vector Dynamics Systems Required for Double Section Homes (Materials Required)

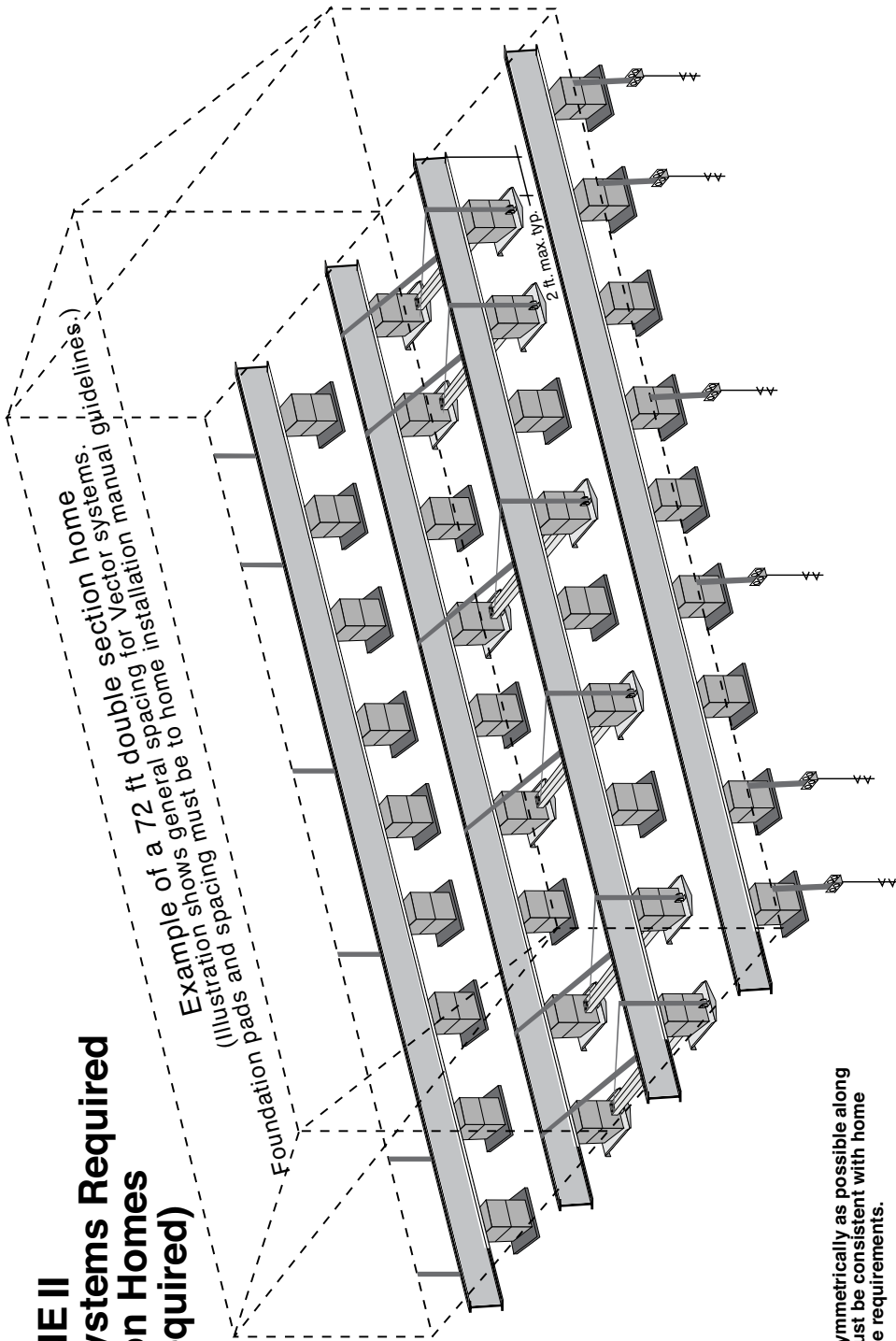

Example of a 72 ft double section home
(Illustration shows general spacing for Vector systems
Installation manual guidelines.)
Foundation pads and spacing must be to home installation manual guidelines.)

Maximum allowable working drag load for the Vector System with the steel compression strut is 3,150 pounds per the K2 Engineering test report.

NOTE: Vector Systems should be spaced as symmetrically as possible along the length of the home. Pier spacing must be consistent with home manufacturers' instructions and/or state requirements.

Soil Classifications: 2, 3, 4A, & 4B
Soil Bearing Capacity: 1,000 PSF minimum
Anchors Required*: 30" with 4" helix anchor (59095),
1-1/4" vertical ties w/4725 lbs. min. breaking strength.

Home Length	Vector Systems Required	Anchors Required Per Side *
0 to 48'	4	4
49' to 60"	5	5
61' to 72'	6	6
73" to 84'	7	7
85' to 90'	8	8

- Each Vector Foundation System requires**
- One Vector Kit, 2 slotted bolts
 - 2 ea. 1-1/4 in. ties, length will vary with pier height (4725 lb. min. break).
 - 1 ea. 4 x 4 pressure treated wood compression member
 - or 2 ea. 2 x 4 pressure treated wood compression member
 - or 1 ea. 3-1/2" or 4" nominal SCH 40 PVC pipe compression member
 - or 1 TDE adjustable steel Strut

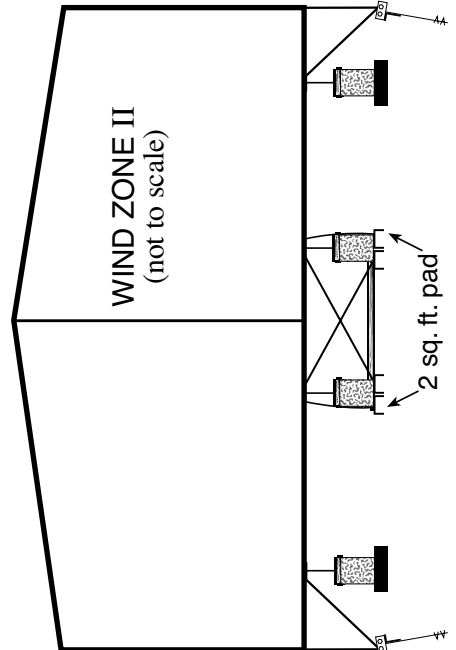

WIND ZONE 2 Vector Dynamics Systems Required 3 Section Homes (Materials Required)

Maximum allowable working drag load for the Vector System with the steel compression strut is 3,150 pounds per the K2 Engineering test report.

WIND ZONE 2

NOTE: Longitudinal stabilization is required. Vector systems should be spaced as evenly as possible along the length of the home. Pier spacing must be consistent with the home installation manual.

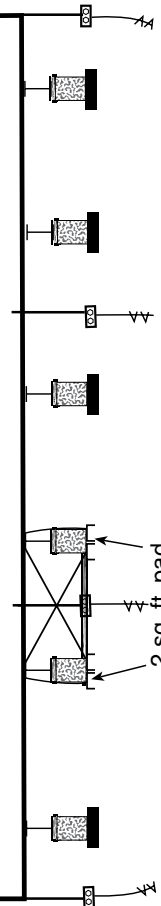

Materials:
*Anchors Required:

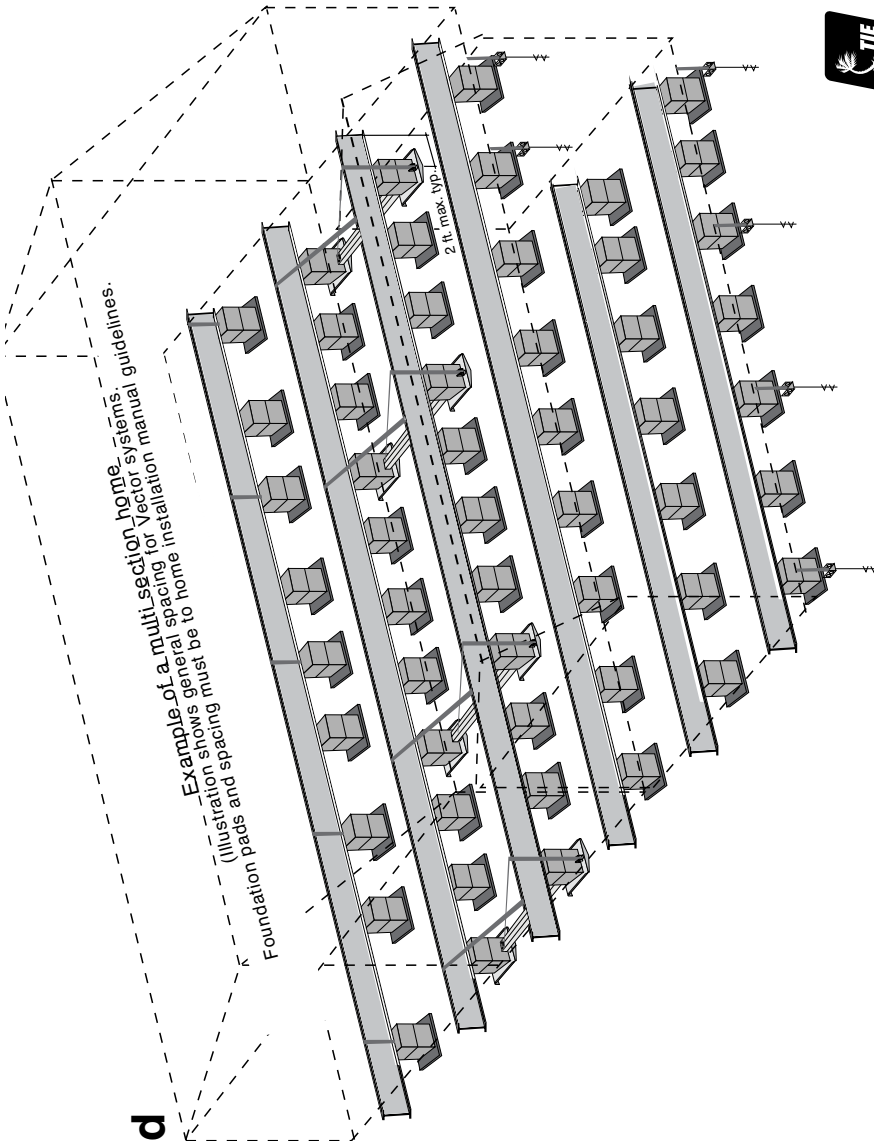

Soil Classifications: 2, 3, 4A, & 4B
Soil Bearing Capacity: 1,000 PSF minimum

Home Length	Vector Systems Required	*Anchors Required Per Side
Homes up to 48'	4 Vector Foundation Systems	4
Homes over 49' up to 60'	5 Vector Foundation Systems	5
Homes over 61' up to 72'	6 Vector Foundation Systems	6
Homes over 73' up to 84'	7 Vector Foundation Systems	7
Homes over 85' up to 90'	8 Vector Foundation Systems	8

Each Vector foundation system requires
One Vector Kit
2 ea. 1-1/4 in. ties (4725 lb. min. break)
1 ea. 4 x 4 wood compression member
or 2 ea. 2 x 4 wood compression member
or 3-1/2" or 4" nominal SCH40 Pipe
compression member or 1 TDE adjustable
steel strut

3/4" x 30" anchor (59095),
with vertical straps

**ZONE III (Hurricane)
Vector Dynamics Systems Required
for Single Section Homes
(Materials Required)**

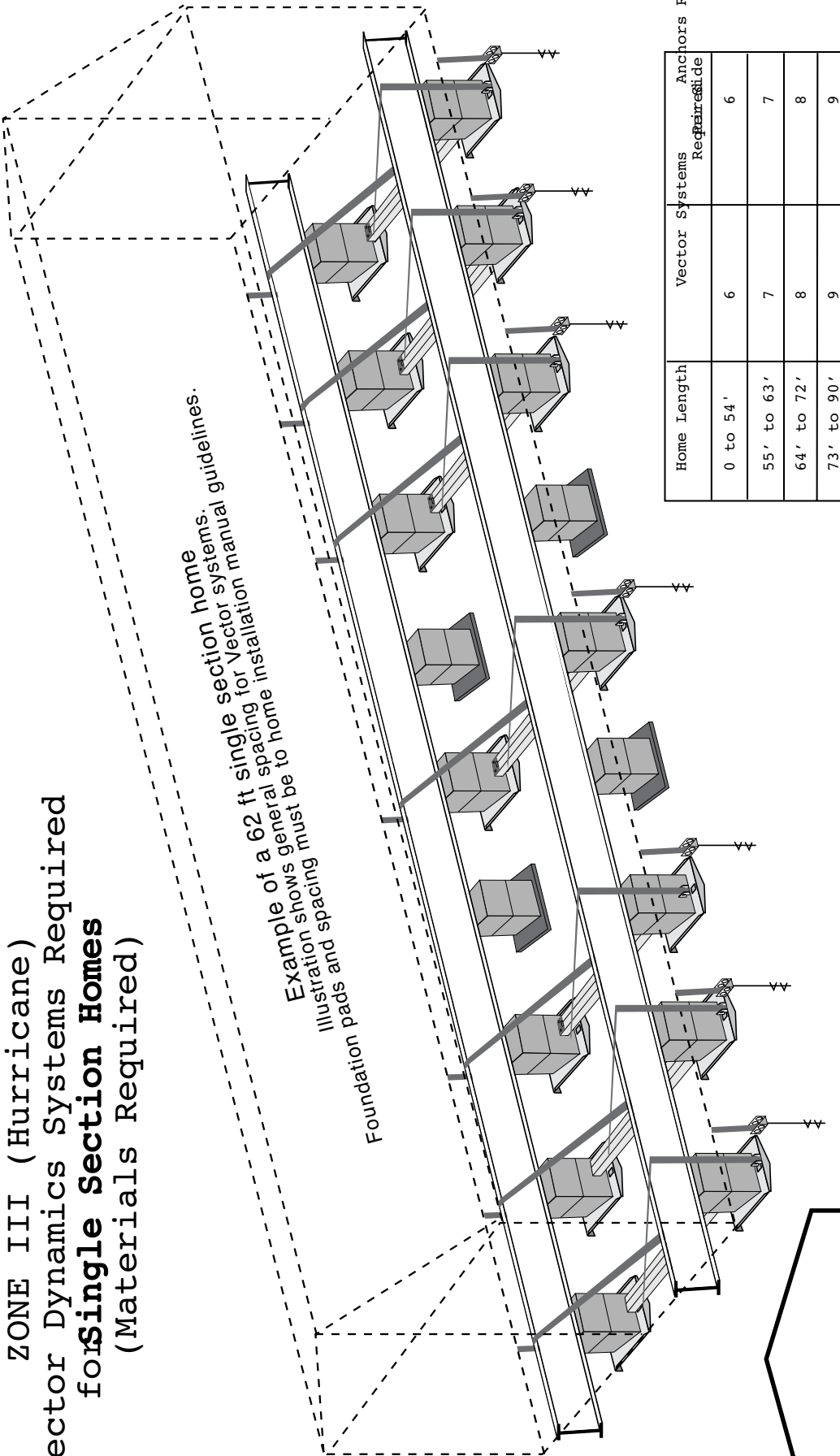

Home Length	Vector Systems Required	Anchors R
0 to 54'	6	6
55' to 63'	7	7
64' to 72'	8	8
73' to 90'	9	9

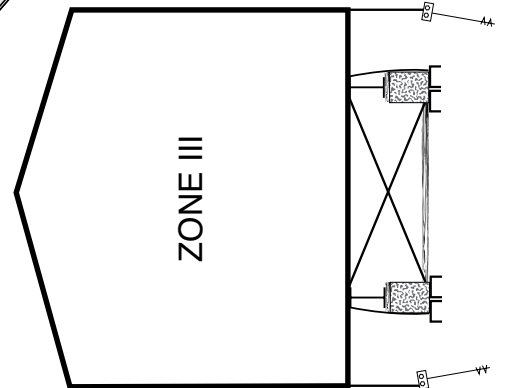

For Soil Classification: 3, 4A, & 4B
 Soil Bearing Capacity: 1,000 PSI minimum
 Anchors Required*: 3/4" x 30" with 4" helix anchor (59095)
 1-1/4" vertical ties w/4725 lbs. min. breaking strength.

NOTE: Vector Systems should be evenly spaced along length of home.
 *Additional marriage wall anchors may be required by home manufacturer.



ZONE III (Hurricane) Vector Dynamics Systems for Double Section Homes (Materials Required)

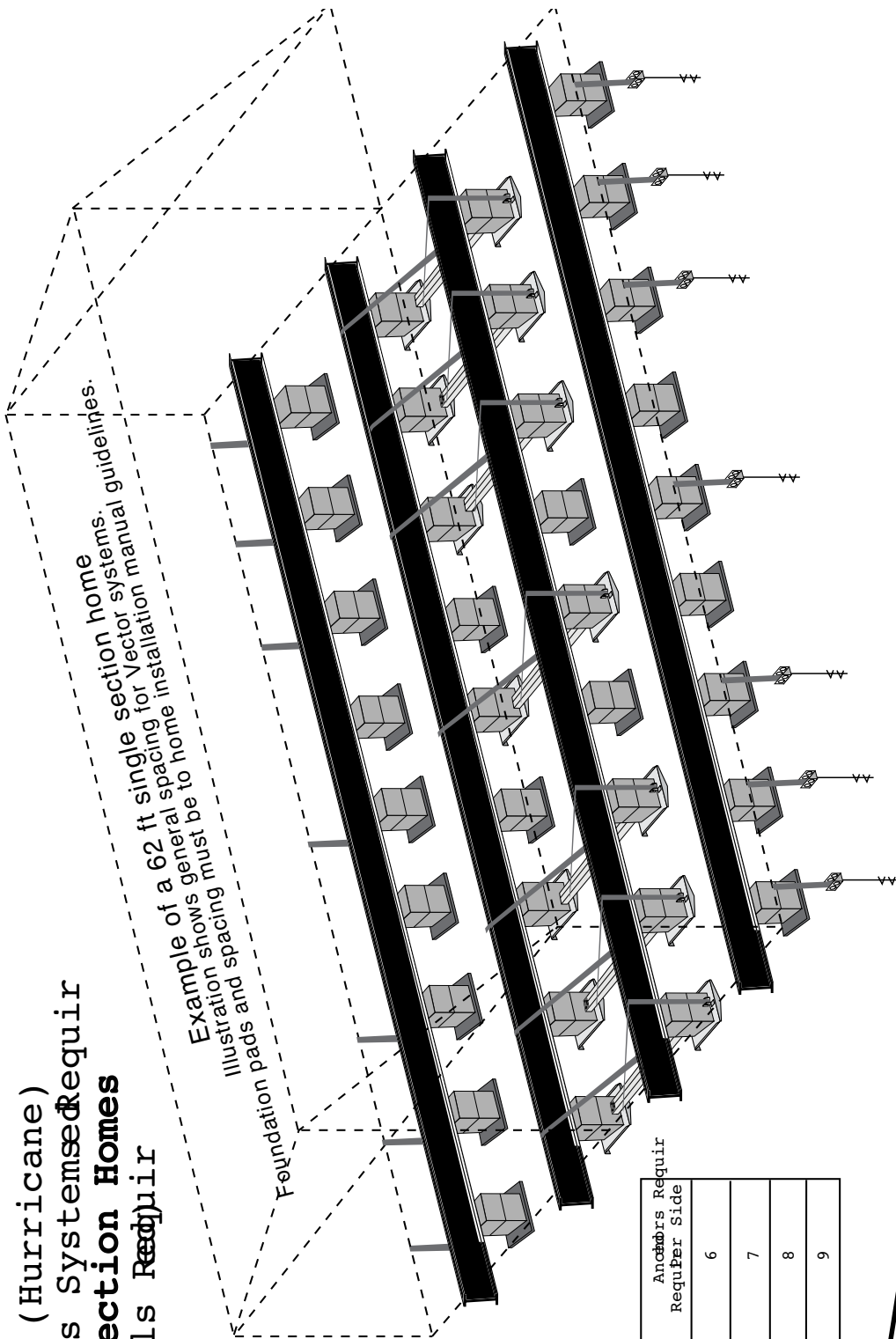

Home Length	Vector Systems Required	Anchors Required Per Side
0 to 54'	6	6
55' to 63'	7	7
64' to 72'	8	8
73' to 90'	9	9

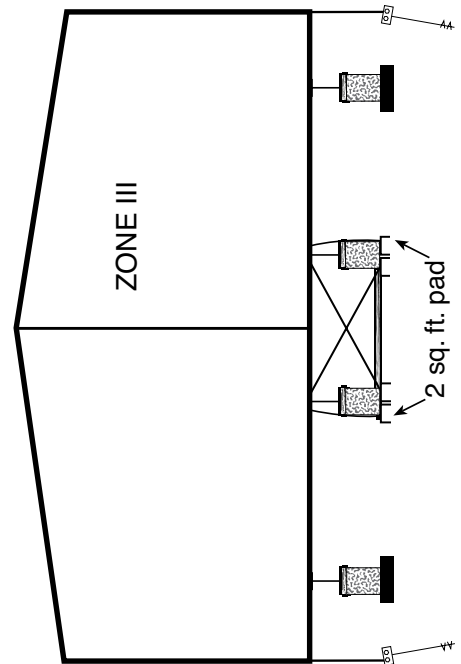

For Soil Classification: 3, 4A, & 4B
 Soil Bearing Capacity: 1,000 PSI minimum
 Anchors Required: 3/4" x 30" with 4" helix anchor (59095).
 1-1/4" vertical ties with 25 lb breaking strength.

NOTE: Vector Systems should be evenly spaced along length of home
 *Additional marriage wall anchors may become manufacturer



WIND ZONE III Vector Dynamics Systems Required 3 Section Homes (Materials Required)

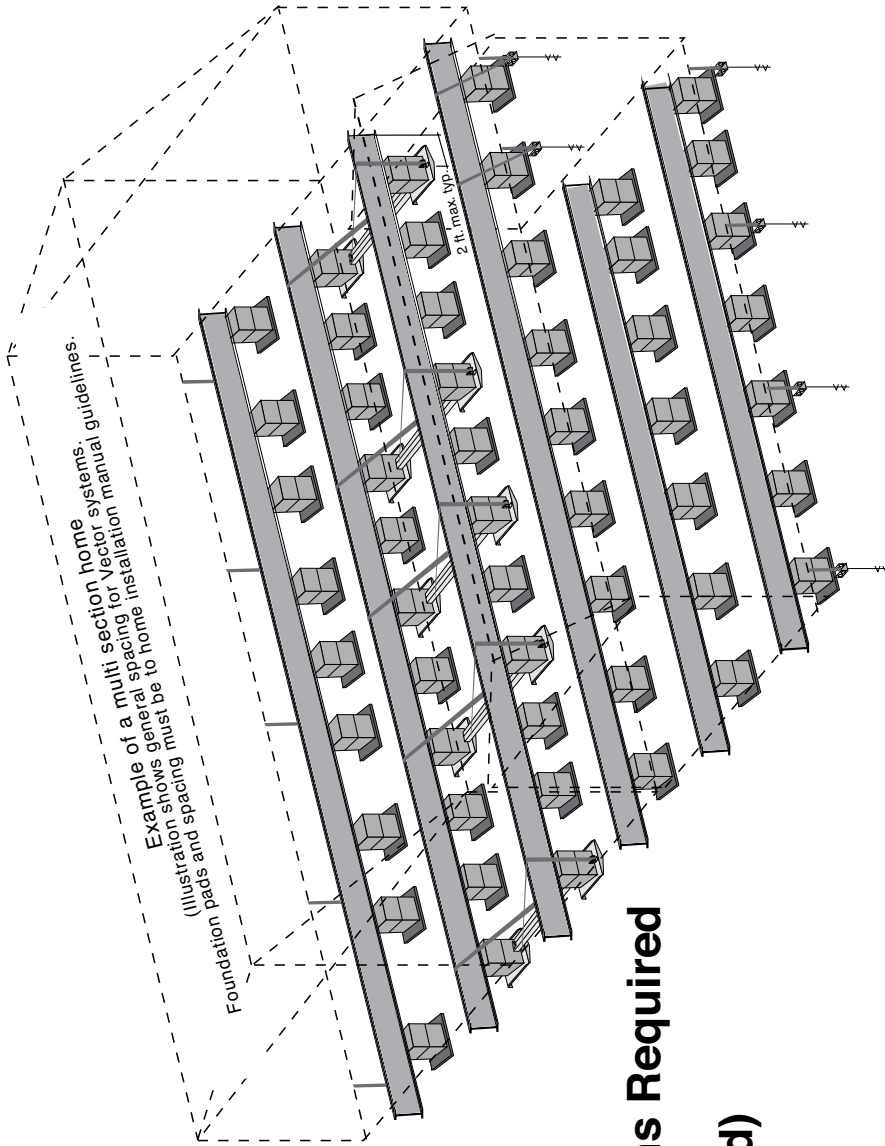

Soil Classifications: 2, 3, 4A, & 4B
Soil Bearing Capacity: 1,000 PSF minimum

Home Length	Vector Systems Required	*Anchors Required Per Side
Homes up to 48'	5 Vector Foundation Systems	5
Homes over 49' up to 60'	6 Vector Foundation Systems	6
Homes over 61' up to 72'	7 Vector Foundation Systems	7
Homes over 73' up to 84'	8 Vector Foundation Systems	8
Homes over 85' up to 90'	9 Vector Foundation Systems	9

Each Vector foundation system requires
One Vector Kit
2 ea. 1-1/4 in. ties (4725 lb. min. break)
1 ea. 4 x 4 wood compression member
or 2 ea. 2 x 4 wood compression member
or 3-1/2 or 4" nominal SCH40 Pipe
compression member or 1 TDE adjustable
steel strut

3/4" x 30" anchor (59095),
1-1/4" vertical ties w/4725 lbs. min.
breaking strength.

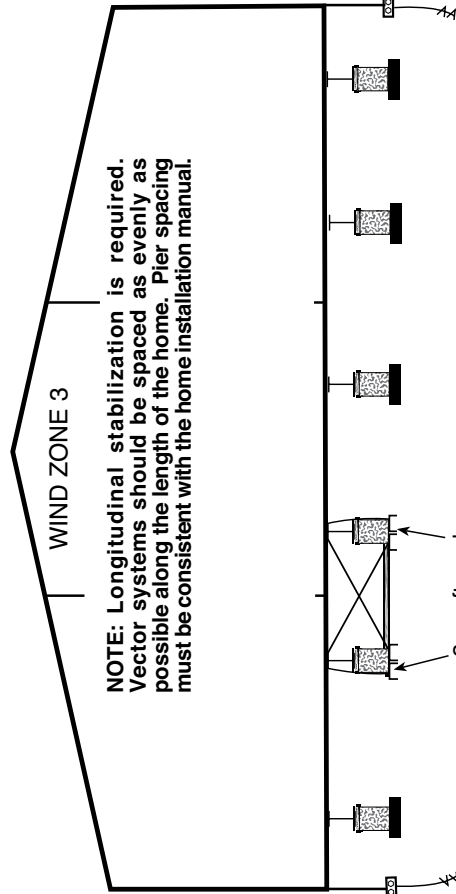

Materials:
* Anchors Required:

Maximum allowable working drag load for the Vector System with the steel compression strut is 3,150 pounds per the K2 Engineering test report.



VECTOR DYNAMICS INSTALLATION DESIGN INSTRUCTIONS

This Vector Dynamics Foundation system instruction is applicable only on homes set on soils classified as Class 4A 4B, 3 and 2 as described in the table below. For separate instructions for sub-soil, Class 5 conditions (above 50 in. lbs.), contact Tie Down Engineering.

SOIL CLASSIFICATIONS

Soil Class	Types of Soils	Blow Count (ASTM D1586)	Soil Test Probe (1) Torque Value (2)
1	Sound hard rock.....	NA	NA
2	Very dense and/or cemented sands, coarse gravel and cobbles, preloaded silts, clays, and corals	40-up	More than 550 in. lbs.
3	Medium-dense coarse sands, sandy gravels, very stiff silts and clays	24-39	350-549 in. lbs.
4A	Loose to medium dense sands, firm to stiff clays and silts, alluvian fill	14-23	275-349 in. lbs
4B			175-275 in. lbs
5	Peat, organic silts, inundated silts, loose fine sand, alluvium, loess, varied clays, fill, fly ash.	0-14	175 in. lbs and lower

(1) The purpose of the soil test probe is to gage the strength of the soil below the surface and near the anchor's helical plate. The strength of the soil is estimated in terms of its' resistance to penetration (flow) under load by means of the torque probe and is measured in inch lbs. The test probe has a helix on it. The overall length of the helical section is 10.75 in.; the major diameter is 1.25 in.; the minor diameter is 0.81 in.; the pitch is 1.75 in. The shaft must be of suitable length for anchor depth.

(2) A measure synonymous with moment of a force when distributed around the shaft of the test probe.

Information about geographical areas of termite infestations which might require the optional termite and moisture shield when a wood compression member is used may be obtained from the local building official or may be found in the 1995 edition of the One and Two Family Dwelling Code.

