



BXUV.G502 - Fire-resistance Ratings - ANSI/UL 263

Design/System/Construction/Assembly Usage Disclaimer

- Authorities Having Jurisdiction should be consulted in all cases as to the particular requirements covering the installation and use of UL Certified products, equipment, system, devices, and materials.
- Authorities Having Jurisdiction should be consulted before construction.
- Fire resistance assemblies and products are developed by the design submitter and have been investigated by UL for compliance with applicable requirements. The published information cannot always address every construction nuance encountered in the field.
- When field issues arise, it is recommended the first contact for assistance be the technical service staff provided by the product manufacturer noted for the design. Users of fire resistance assemblies are advised to consult the general Guide Information for each product category and each group of assemblies. The Guide Information includes specifics concerning alternate materials and alternate methods of construction.
- Only products which bear UL's Mark are considered Certified.

BXUV - Fire Resistance Ratings - ANSI/UL 263 Certified for United States

BXUV7 - Fire Resistance Ratings - CAN/ULC-S101 Certified for Canada

[See General Information for Fire-resistance Ratings - ANSI/UL 263 Certified for United States Design Criteria and Allowable Variances](#)

[See General Information for Fire Resistance Ratings - CAN/ULC-S101 Certified for Canada Design Criteria and Allowable Variances](#)

Design No. G502

February 04, 2021

Restrained Assembly Rating — 1-1/2 Hr.

Unrestrained Assembly Rating — 1-1/2 Hr.

This design was evaluated using a load design method other than the Limit States Design Method (e.g., Working Stress Design Method). For jurisdictions employing the Limit States Design Method, such as Canada, a load restriction factor shall be used — See Guide [BXUV](#) or [BXUV7](#)

*** Indicates such products shall bear the UL or cUL Certification Mark for jurisdictions employing the UL or cUL Certification (such as Canada), respectively.**

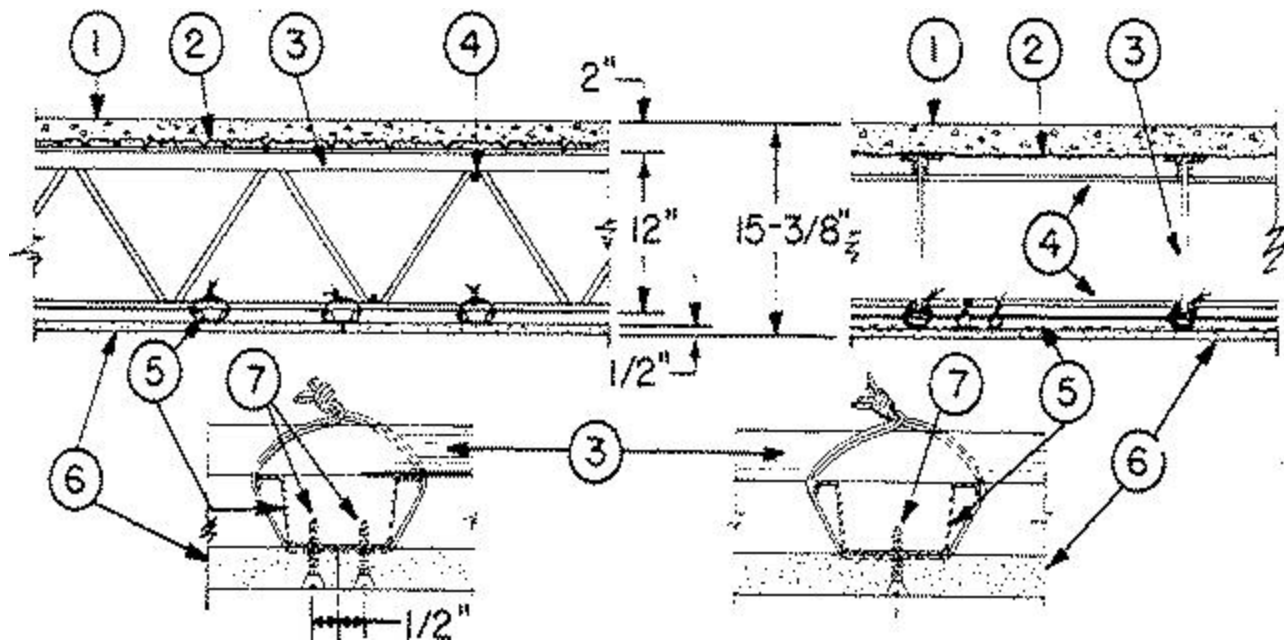

1. **Normal Weight or Lightweight Concrete** — carbonate or siliceous aggregate, 150 + or - 3 pcf unit weight, 3000-psi compressive strength. Lightweight concrete, expanded shale, clay or slate aggregate by rotary kiln method, 117 + or - 3 pcf unit weight, 3000-psi compressive strength.

2. **Metal Lath** — 3/8 in. rib, 3.4 lb/sq yd expanded steel lath tied to each joist at every other rib and midway between joists at side laps with 18 SWG galv steel wire. As an alternate, the form material for the concrete may be corrugated steel deck, 9/16 in. deep of 28 MSG (min) galv steel welded to supports 15 in. OC with welding washers. The concrete topping thickness shall be measured to the top plane of the steel deck.

2A. **Steel Floor and Form Units*** — (Not shown) As an alternate to Item 2, Composite 1-1/2 in. deep, 30, 35 or 36 in. wide, galv steel units. Min gauge is 22 MSG. Welded to supports 12 in. OC. Adjacent units button-punched, welded or screwed together 36 in. OC max along side joints. The concrete thickness shall be measured to the top plane of the steel deck.

VULCRAFT, DIV OF NUCOR CORP — Types 1.5VL, 1.5VLI, 1.5PLVLI

3. **Steel Joists** — Type 12J4 or 12K1 min size, spaced 24 in. OC and welded to end supports.

4. **Horizontal Bridging** — 1/2 in. diam continuous steel bar stock; welded to top and bottom chords of each joist.

5. **Furring Channels** — No. 25 MSG galv steel, 2-5/16 in. or 2-9/16 in. or 2-23/32 in. wide at top and 1-3/8 in. wide at bottom by 7/8 in. deep; spaced perpendicular to joists at 24 in. OC except at wallboard end joints as noted below. Channels secured to each joist with double strand of 18 SWG galv steel wire. Channels spliced with adjoining pieces overlapped 6 in. and tied together with double strand of 18 SWG galv steel wire at each end of overlap. As an alternate, furring channels may be secured to 1-1/2 in. cold-rolled steel channels at every intersection with double strand of 18 SWG galv steel wire. Cold-rolled channels spaced 24 in. OC and suspended perpendicular from lower chords of joists with 8 SWG galv steel wire spaced 48 in. OC along channels.

5A. **Steel Framing Members*** — (optional, not shown) — alternate method to attach furring channels (Item 5) to joists (Item 3). Clips spaced 48 in. OC., and secured to alternating joists with cup washer installation kit provided by manufacturer. On underside of bottom chord, 1-1/2 in. dia x 3/8 in. deep #16 galv steel cup washer is placed to surround the rubber insert of RSIC-1 and RSIC-1 (2.75) clips. RSIC-1 and RSIC-1 (2.75) clips attached to the bottom chord with a 1/4 in. dia. zinc plated bolt inserted through the center grommet and between the chord members; depth of bolt determined as 1-1/2 in. plus the depth of the bottom chord of the joist. RSIC-V and RSIC-V (2.75) clips attached to the bottom chord with a 1/4 in. dia. zinc plated bolt inserted through the center hole and between the chord members; depth of bolt determined as 9/16 in. plus the depth of the bottom chord of the joist. Fastened on the top side of the bottom chord with a second cup washer placed open side up, and a 1/4 in. zinc plated "Nyloc" nut. Furring channels are friction fitted into

clips. RSIC-1 and RSIC-V clips for use with 2-9/16 in. wide furring channels. RSIC-1 (2.75) and RSIC-V (2.75) clips for use with 2-23/32 in. wide furring channels. Ends of adjoining channels are overlapped 6 in. and tied together with double strand of No. 18 SWG galv steel wire near each end of overlap. As an alternate, ends of adjoining channels may be overlapped 6 in. and secured together with two self-tapping #6 framing screws, min. 7/16 in. long at the midpoint of the overlap, with one screw on each flange of the channel. Additional clips required to hold furring channel that supports the wallboard butt joints, as described in Item 6.

PAC INTERNATIONAL L L C — Types RSIC-1, RSIC-V, RSIC-1 (2.75), RSIC-V (2.75).

5B. Steel Framing Members* — (optional, not shown) — alternate method to attach 2-5/16 in. wide furring channels (Item 5) to joists (Item 3). Clips spaced 48 in. OC., and secured to alternating joists with cup washer installation kit provided by manufacturer. On underside of bottom chord, 1-1/2 in. dia x 3/8 in. deep #16 galv steel cup washer is placed to surround the rubber insert of GenieClip. GenieClip attached to the bottom chord with a 1/4 in. dia. zinc plated bolt inserted through the center grommet and between the chord members; depth of bolt determined as 1-1/2 in. plus the depth of the bottom chord of the joist. Fastened on the top side of the bottom chord with a second cup washer placed open side up, and a 1/4 in. zinc plated "Nyloc" nut. Furring channels are friction fitted into clips. Ends of adjoining channels are overlapped 6 in. and tied together with double strand of No. 18 SWG galv steel wire near each end of overlap. As an alternate, ends of adjoining channels may be overlapped 6 in. and secured together with two self-tapping #6 framing screws, min. 7/16 in. long at the midpoint of the overlap, with one screw on each flange of the channel. Additional clips required to hold furring channel that supports the wallboard butt joints, as described in Item 6.

PLITEQ INC — Type GENIECLIP

5C. Steel Framing Members* — (Optional, Not Shown) - Used as an alternate method to attach furring channels to joists. Clips spaced at 48" OC and secured to the bottom of the joists with cup washer installation kit provided by manufacturer. On underside of bottom chord, 1-1/2 in. dia x 3/8 in. deep No. 16 galv steel cup washer is placed to surround the rubber insert of clip. Clip attached to the bottom chord with a 1/4 in. dia zinc plated bolt inserted through the center grommet and between the chord members; depth of bolt determined as 1-1/2 in. plus the depth of the bottom chord of the joist. Fastened on the top side of the bottom chord with a second cup washer placed open side up, and a 1/4 in. zinc plated "Nyloc" nut. Furring channels are then friction fitted into clips. Ends of channels are overlapped 6" and tied together with double strand of No. 18 AWG galvanized steel wire. Additional clips are required to hold the Gypsum Butt joints as described in Item 6.

STUDCO BUILDING SYSTEMS — RESILMOUNT Sound Isolation Clips - Type A237 or A237R

5D. Steel Framing Members* — (Optional, Not Shown) - Used as an alternate method to attach furring channels to joists. Clips spaced at 48" OC and secured to the bottom of the joists with cup washer installation kit provided by manufacturer. On underside of bottom chord, 1-1/2 in. dia x 3/8 in. deep No. 16 galv steel cup washer is placed to surround the rubber insert of clip. Clip attached to the bottom chord with a 1/4 in. dia zinc plated bolt inserted through the center grommet and between the chord members; depth of bolt determined as 1-1/2 in. plus the depth of the bottom chord of the joist. Fastened on the top side of the bottom chord with a second cup washer placed open side up, and a 1/4 in. zinc plated "Nyloc" nut. Furring channels are then friction fitted into clips. Ends of channels are overlapped 6" and tied together with double strand of No. 18 AWG galvanized steel wire. Additional clips are required to hold the Gypsum Butt joints as described in Item 6.

REGUPOL AMERICA — Type SonusClip

6. Gypsum Board* — 1/2 in. thick, installed with long dimension perpendicular to furring channels and side joints located midway between steel joists. Wallboard sheets fastened to furring channels with wallboard screws spaced 12 in. O.C. and located no less than 1/2 in. from butted side and end joints. End joints of wallboard similarly fastened 8 in. O.C. to additional pieces of furring channel a minimum of 52 in. long, which are attached to joists and extend 4 in. over adjacent wallboard sheets. Adjacent sheets secured to end joint furring channel with an additional wallboard screw. End joints of wallboard in adjacent courses staggered. Where wallboard is other than 48 in. wide, length of additional channel sections

at end joints may be adjusted to permit wire tie to joist to occur not less than 16 in. from end of channel. Joint treatment not required for this rating, except for tapered, round-edge wallboard where edge joints are covered with paper tape and joint compound. As an alternate, nominal 3/32 in. thick gypsum veneer plaster may be applied to the entire surface of Classified veneer baseboard. Joints reinforced.

When **Steel Framing Members** (Item 5A or 5B) are used, wallboard butt joints shall be staggered min. 2 ft. within the assembly, and occur between the main furring channels. Edge joints may occur beneath the joists. At the wallboard butt joints, each end of the gypsum board shall be supported by a single length of furring channel equal to the width of the wallboard plus 6 in. on each end. The furring channels shall be spaced approximately 3-1/2 in. OC, and be attached to underside of the joist with one clip at each end of the channel. Gypsum board attached to the furring channels using 1 in. long Type S bugle-head steel screws spaced 8 in. OC along butted end joints and 12 in. OC in the field of the board. Wallboard joints covered with fiber tape and joint compound.

When **Steel Framing Members** (Item 5C) are used, gypsum board is installed with long dimensions perpendicular to furring channels. Gypsum board secured to furring channels with nom 1 in. long Type S bugle-head steel screws spaced 8 in. OC in the field of the board. Gypsum board butted end joints shall be staggered minimum 48 in. and centered over main furring channels. At the gypsum board butt joints, each end of each gypsum board shall be supported by a single length of furring channel equal to the width of the gypsum board plus 3 in. on each end. The two supporting furring channels shall be spaced approximately 3 in. in from end joint. Screw spacing along the gypsum board butt joint and along both additional furring channels shall be 8 in. OC. Additional screws shall be placed in the adjacent section of gypsum board into the aforementioned 3 in. extension of the extra butt joint channels as well as into the main channel that runs between. Butt joint furring channels shall be attached with one RESILMOUNT Sound Isolation Clip at each end of the channel.

When **Steel Framing Members** (Item 5D) are used, gypsum board is installed with long dimensions perpendicular to furring channels. Gypsum board secured to furring channels with nom 1 in. long Type S bugle-head steel screws spaced 8 in. OC in the field of the board. Gypsum board butted end joints shall be staggered minimum 48 in. and centered over main furring channels. At the gypsum board butt joints, an additional single length of furring channel shall be installed and be spaced approximately 3 in. from the butt joint (6 in. from the continuous furring channels) to support the floating end of the gypsum board. Each of these shorter sections of furring channel shall extend one joist beyond the width of the gypsum panel and be attached to the joists with one SonusClip at every joist involved with the butt joint.

AMERICAN GYPSUM CO — Type AG-C

CABOT MANUFACTURING ULC — Type C

CERTAINTED GYPSUM INC — Type C, Type LGFC-C/A

CGC INC — Type C, IP-X2, IPC-AR.

GEORGIA-PACIFIC GYPSUM L L C — Types 5, C, GPFS1, DAP, DA, DAPC, Type TG-C.

NATIONAL GYPSUM CO — Types FSK-1, FSK-C, FSK-G, FSW-1, FSW-C, FSW-G.

PABCO BUILDING PRODUCTS L L C, DBA PABCO GYPSUM — Types PG-1, PG-3, PG-C.

PANEL REY S A — Type PRC

THAI GYPSUM PRODUCTS PCL — Type C.

THE SIAM GYPSUM INDUSTRY (SONGKHLA) CO — Type C

UNITED STATES GYPSUM CO — Type C, IP-X2, IPC-AR

USG BORAL DRYWALL SFZ LLC — Type C

USG MEXICO S A DE C V — Types C, IP-X2, IPC-AR.

6A. **Gypsum Board*** — (Not Shown), as an alternate to Item 6. 5/8 in. thick, installed as described in Item 6.
CGC INC — Type ULIX

UNITED STATES GYPSUM CO — Type ULIX

7. **Screw, Wallboard** — No. 6 Phillips-type, self drilling and self tapping, 1 in. long. Screw heads may be either exposed or covered with joint cement.

*** Indicates such products shall bear the UL or cUL Certification Mark for jurisdictions employing the UL or cUL Certification (such as Canada), respectively.**

Last Updated on 2021-02-04

The appearance of a company's name or product in this database does not in itself assure that products so identified have been manufactured under UL's Follow-Up Service. Only those products bearing the UL Mark should be considered to be Certified and covered under UL's Follow-Up Service. Always look for the Mark on the product.

UL permits the reproduction of the material contained in the Online Certification Directory subject to the following conditions: 1. The Guide Information, Assemblies, Constructions, Designs, Systems, and/or Certifications (files) must be presented in their entirety and in a non-misleading manner, without any manipulation of the data (or drawings). 2. The statement "Reprinted from the Online Certifications Directory with permission from UL" must appear adjacent to the extracted material. In addition, the reprinted material must include a copyright notice in the following format: "© 2021 UL LLC"