

Organization
Introduction

Design Wind Bracing Between Framing Columns 3N & 4N (Similar between 3O and 4O)

Assumptions : $F_y = 50\text{ksi}$ $F_u = 65\text{ksi}$ (Typical L shape is A36)

Level 1 to Level 2 - Using same design for L2 to L3 and L3 to L4.

Designed bracing to resist "tension only" due to Wind loads, Row N resists 50% of the East/West wind load and row O resists 50% of the load. Each bracing will not support any gravity loads. Assume that the East/West wind produces 40 psf.

East or West Building Area - from mid height on Level 1 to Level 6
Area between column rows * 3 plus 1 ft each side of columns rows times 3 1/2 floors + 3 ft parapet. Add this to the area of Level 6. Multiply all of this by the force

$$[(3 * 24) + 2] * [(3.5 * 14) + 3] + 13 (24 + 2) \\ = [(74) * (52)] + [13 * 26] = 3848 + 338 = 4186 \text{ ft}^2 * 40 \text{ \#/ft}^2 = 167440 \text{ or } 167.4^k$$

Each row of columns N and O will withstand 1/2 of the wind $167.4 / 2 = 83.7^k$

$$\text{Length of the diagonal} = \sqrt{(33^2 + 14^2)} = \sqrt{1285} = 35.85 \text{ ft}$$

$$\text{Each diagonal tension force} = \text{ratio} * \text{force} = 35.85/33' * 83.7^k = 90.9^k(t)$$

Gross section yielding

$$P_n = F_y * A_g$$

$$\text{LRFD } \Phi_t = 0.90 \text{ \& Load} = 1.6W \\ \text{Load} = \Phi_t * P_n = \Phi_t * F_y * A_g \\ A_g = \text{Load} / \Phi_t * F_y \\ A_g = 90.9^k * 1.6 / (0.9 * 50\text{ksi}) \\ A_g = 145.44^k / 45 \text{ ksi} = 3.23 \text{ in}^2$$

$$\text{ASD } \Omega_t = 1.67 \text{ \& Load} = 1.0W \\ \text{Load} = P_n / \Omega_t = F_y * A_g / \Omega_t \\ A_g = \text{Load} * \Omega_t / F_y \\ A_g = 90.9^k * 1.67 / 50\text{ksi} \\ A_g = 151.8 / 50\text{ksi} = 3.04 \text{ in}^2$$

Tensile rupture strength

$$P_n = F_u * A_e$$

$$\text{LRFD } \Phi_t = 0.75 \\ \text{Load} = \Phi_t * P_n = \Phi_t * F_u * A_e \\ A_e = \text{Load} / \Phi_t * F_u \\ A_e = 90.9^k / 0.75 * 65\text{ksi} \\ A_e = 90.9^k / 48.75\text{ksi} = 1.86 \text{ in}^2$$

$$\text{ASD } \Omega_t = 2.00 \\ \text{Load} = P_n / \Omega_t = F_u * A_e / \Omega_t \\ A_e = \text{Load} * \Omega_t / F_u \\ A_e = 90.9^k * 2 / 65\text{ksi} \\ A_e = 181.8^k / 65\text{ksi} = 2.80 \text{ in}^2$$

$$r_{x,y} \text{ minimum} = L/300 \\ r_{x,y} = 35.85 \text{ ft} * 12 \text{ in/ft} / 300$$

$$r_{x,y} \text{ minimum} = L/300 \\ r_{x,y} = 430.2 / 300 = 1.434$$

Try L shape bracing:
L6x6x3/8

Wt. 14.9 #/ft

$A_g = 4.38 \text{ in}^2$

$r = 1.87 \text{ in}$

For 3/4" A325-N bolts

LRFD Capacity 15.9 k/bolt

ASD Capacity 10.6 k/bolt

Diagonal Force/bolt Capacity

LRFD
 $145.44 \text{ k} / 15.9 \text{ k} = 9.1 \text{ bolts}$

ASD
 $90.9 \text{ k} / 10.6 \text{ k} = 8.6 \text{ bolts}$

Use two lines of 5 bolts

Table D3.1 AISC Case 8 Single angle with more than 4 fasteners per line use $U = 0.80$

$$A_e = U * A_n = 0.8 [4.38 \text{ in}^2 - 2(3/8") (3/4" + 1/8")] = 0.8 [4.38 - 0.656] = 0.8 * 3.723 = 2.98 \text{ in}^2$$

This A_e meets the Tensile Rupture Strength requirements calculated with ASD.

Level 4 to Level 5 - Both tension and compression.

Designed bracing to resist "both tension and compression" due to Wind loads, Row N resists 50% of the East/West wind load and row Q resists 50% of the load. Each bracing will not support any gravity loads. Assume that the East/West wind produces 40 psf.

East or West Building Area - from mid height on Level 4 to Level 6

$$[(3 * 24) + 2] * (16/2 + 3) + 13 (24 + 2) \\ = [(74) * (11)] + [13 * 26] = 814 + 338 = 1152 \text{ ft}^2 * 40 \text{ #/ft}^2 = 46080 \text{ or } 46.1 \text{ k}$$

Each row of columns N and Q will withstand 1/2 of the wind $46.1 / 2 = 23.1 \text{ k}$

$$\text{Length of the diagonal} = \sqrt{(33^2 + 14^2)} = \sqrt{1285} = 35.85 \text{ ft}$$

$$\text{Each diagonal force} = \text{ratio} * \text{force} = 35.85'/33' * 23.1 \text{ k} = 25.1 \text{ k (t \& c)}$$

$$\text{ASD} = 25.1 \text{ k (t \& c)} \quad \text{LRFD} = 1.6 * 25.1 \text{ k} = 40.2 \text{ k (t \& c)}$$

$$\text{AISC Pg 4-54, KL shown at } 36' - \text{HSS } 7 \times 7 \times 3/16 \text{ ASD} = 29.0 \text{ LRFD} = 43.6$$

$$KL/r = 200$$

$$r = KL/200$$

$$r = (1) * (35.85') * (12''/') / 200 = 2.15''$$

Try HSS 7 x 7 x 3/16; $A=4.67 \text{ in}^2$; $r=2.77 \text{ in}$; $F_y = 46 \text{ ksi}$ $W_t = 17.06 \text{ #/ft}$ (AISC pg 1-53)

$$\text{Check } KL/r = (1) * (35.85') * (12''/') / 2.77 = 155.3$$

$$F_e = (\pi^2 * 29,000) / (155.3)^2 = 11.87 \text{ ksi} < .44 * (46 \text{ ksi}) = 20.2 \text{ ksi} \quad \text{ELASTIC}$$

$$F_{cr} = .877 F_e = .877 * 11.87 \text{ ksi} = 10.41 \text{ ksi}$$

$$P_n = F_{cr} * A_g$$

$$\text{LRFD } \Phi_c = 0.90$$

$$\text{ASD } \Omega_c = 1.67$$

$$\Phi_c * P_n$$

$$P_n / \Omega_c$$

$$0.9 * 10.41 \text{ ksi} * 4.67 = 43.7 \text{ k}$$

$$10.41 \text{ ksi} * 4.67 \text{ in}^2 / 1.67 = 29.1 \text{ k}$$

Check Required/Capacity

$$40.2/43.7$$

$$25.1/29.1$$

- Use same HSS 7 x 7 x 3/16 for Level 5 to Level 6
Column Design

Assumptions : $F_y = 50\text{ksi}$ $F_u = 65\text{ksi}$

Dead Load : 100 psf

Exterior Wall System : 50 psf (Supported mid-height of each floor)

Live Load : L2, L3, L4 = 120 psf

L5, L6 (L_r) = 60 psf

Wind Load: 40 psf (Service Level)

Seismic Load: None

Exterior non-corner columns - M2, M3, M4, M5, P2, P3, P4, P5, N1, N6, O1, O6

Exterior corner columns - M1, M6, P1, P6 all have lower loads but use same section as Exterior non-corner columns.

Non Rigid Frame Column Splice: Mid-Height between Level 2 and Level 3 only, from this splice to top is single unit.

ASD load cases $D + L$ & $D + .75L + .75L_r$

LRFD load cases $1.2D + 1.6L + 0.5L_r$

Exterior non-corner Column Area per level $33'(24'/2) = 33' (12') = 396 \text{ ft}^2$

Design Load above Splice for Exterior Non-Corner Columns : $L_3 + L_4 + L_5$

D: $[396 \text{ ft}^2 (100 \text{ psf} + 100 \text{ psf} + 100 \text{ psf})] + [33' * (14' + 14' + 10')] * (50 \text{ psf})]$

$= 118,800 + 62,700 = 181,500$ or 181.5^k

L: $[396 \text{ ft}^2 (120 \text{ psf} + 120 \text{ psf})] = 95,040^k$ or 95.0^k

L_r : $396 \text{ ft}^2 (60 \text{ psf}) = 23,760^k$ or 23.8^k

ASD load cases $D + L = 181.5^k + 95.0^k = 276.5^k$ *** USE THIS LOAD ***

$D + .75L + .75L_r = 181.5^k + [.75 * (95.0^k)] + [.75 * (23.8^k)]$

$= 181.5^k + 71.3^k + 17.9^k = 270.7^k$

LRFD load cases $1.2D + 1.6L + 0.5L_r = [1.2 * 181.5^k] + [1.6 * (95.0^k)] + [0.5 * (23.8^k)]$

$= 217.8^k + 152.0^k + 11.9^k = 381.7^k$ *** USE THIS LOAD ***

Above Splice ASD & LRFD :

AISC 13th Pg 4-14; $KL=14'$; W14x61 (50 ksi)

ASD $P_n / \Omega_c = 380^k > 276.5^k$ OK

LRFD $\Phi_c \times P_n = 572^k > 381.7^k$ OK

AISC 13th Pg 4-14; $KL=14'$; W14x53 (50 ksi)

ASD $P_n / \Omega_c = 267^k$ not $> 276.5^k$ NOT OK

LRFD $\Phi_c \times P_n = 401^k > 381.7^k$ OK

Check From Above Splice W14x61 with $KL=14'$

$r_y = 2.45''$; Area = 17.9 in^2 ; AISC Pg 1-22

$Kl/r = (1) * (14') * (12''/1) / 2.45 = 68.6$

$F_e = (\pi^2 * 29,000) / (68.6)^2 = 60.82 \text{ ksi} > .44 * (50 \text{ ksi}) = 22.0 \text{ ksi}$ **INELASTIC CAN NOT USE EULER**

$F_{cr} = (0.658^{50/60.82}) * 50 = (0.658^{0.82209}) * 50 = 35.44 \text{ ksi}$

$P_n = F_{cr} \times A_g$

LRFD $\Phi_c = 0.90$

ASD $\Omega_c = 1.67$

$\Phi_c \times P_n$

P_n / Ω_c

$$0.9 * 35.44 \text{ ksi} * 17.9 \text{ in}^2 = 570.9^k$$

$$35.44 \text{ ksi} * 17.9 \text{ in}^2 / 1.67 = 379.9^k$$

Check Required/Capacity 382/571

277/380

Design Load from Base to Splice :

$L_1 + L_2 + L_3 + L_4 + L_5$ (L_1 Supported by Foundation)

$$D: [396 \text{ ft}^2 (100 \text{ psf} + 100 \text{ psf} + 100 \text{ psf} + 100 \text{ psf})] + [33' * (14' + 14' + 14' + 10') * (50 \text{ psf})]$$

$$= 158,400 + 85,800 = 244,200 \text{ or } 244.2^k$$

$$L: [396 \text{ ft}^2 (120 \text{ psf} + 120 \text{ psf} + 120 \text{ psf})] = 142,560^k \text{ or } 142.6^k$$

$$L_r: 396 \text{ ft}^2 (60 \text{ psf}) = 23.8^k$$

ASD load cases $D + L = 244.2^k + 142.6^k = 386.8^k$ *** USE THIS LOAD ***

$$D + .75L + .75L_r = 244.2^k + [.75 * (142.6^k)] + [.75 * (23.8^k)]$$

$$= 244.2^k + 107.0^k + 17.85^k = 369.1^k$$

LRFD load cases $1.2D + 1.6L + 0.5L_r = [1.2 * (244.2^k)] + [1.6 * (142.6^k)] + [0.5 * (23.8^k)]$

$$= 293.04^k + 228.15^k + 11.9^k = 533.1^k$$
 *** USE THIS LOAD ***

From Base to Splice ASD & LRFD :

AISC 13th Pg 4-14; KL=14'; W14x68 (50 ksi)

$$\text{ASD } P_n / \Omega_c = 425^k > 387^k \text{ OK}$$

$$\text{LRFD } \Phi_c \times P_n = 639^k > 533^k \text{ OK}$$

AISC 13th Pg 4-14; KL=14'; W14x61 (50 ksi)

$$\text{ASD } P_n / \Omega_c = 380^k \text{ NOT} > 387^k \text{ NOT OK}$$

$$\text{LRFD } \Phi_c \times P_n = 572^k > 533^k \text{ OK}$$

Check From Base to Splice W14x68 with KL=14'

$$r_y = 2.46''; \text{ Area} = 20.0 \text{ in}^2; \text{ AISC Pg 1-22}$$

$$KL/r = (1) * (14') * (12''/') / 2.46 = 68.3$$

$$F_e = (\pi^2 * 29,000) / (68.3)^2 = 61.4 \text{ ksi} > .44 * (50 \text{ ksi}) = 22.0 \text{ ksi}$$
 INELASTIC CAN NOT USE EULER

$$F_{cr} = (0.658^{50/61.4}) * 50 = (0.658^{0.81433}) * 50 = 35.56 \text{ ksi}$$

$$P_n = F_{cr} \times A_g$$

$$\text{LRFD } \Phi_c = 0.90$$

$$\text{ASD } \Omega_c = 1.67$$

$$\Phi_c \times P_n$$

$$P_n / \Omega_c$$

$$0.9 * 35.56 \text{ ksi} * 20.0 \text{ in}^2 = 640.1^k$$

$$35.56 \text{ ksi} * 20.0 \text{ in}^2 / 1.67 = 425.9^k$$

Check Required/Capacity 533/640

387/426

CONCLUSION

Exterior Columns (Non-Corners) Above Splice use W14x61 (50 ksi)

Exterior Columns (Non-Corners) from Base to Splice use W14x68 (50 ksi)

Design Interior Columns : N₃; N₄; O₃; O₄

Splices 4 ft above L₂ and 4 ft above L₄ ; Column Area per level = 24' * 33' = 792 ft²

Dead Loads (D)

Above L₄ Splice #1 - (L₅)[792 ft² * 100 psf] + (L₆)[396 ft² * 100 psf] + (Ext Wall)[13' * 33' * 50 psf]
79,200 + 39,600 + 21,450 = 140,250 or 140.2^k

Above L₂ Splice #2 - 140.2^k + [2 * (792 ft² * 100 psf)] = 298.6^k

Base above L₁ - 298.6^k * [792 ft² * 100 psf] = 377.8^k

Floor Live Loads (L)

Above L₄ Splice #1 - (L₅)[396 ft² * 120 psf] = 47.5^k

Above L₂ Splice #2 - (L₅)47.5^k + (L₃ & L₄) [2 * (792 ft² * 120 psf)] = 237.6^k

Base above L₁ - 237.6^k * [792 ft² * 60 psf] = 285.1^k

Roof Live Load (L_r)

Above L₄ Splice #1 - [792 ft² * 60 psf] = 47.5^k

Above L₂ Splice #2 - = 47.5^k

Base above L₁ - = 47.5^k

P1 : 40psf (12/2 + 1) (24/2 + 1) = 3.6k

P2 : 40psf [(12/2 + 1) (24/2 + 1) + (72/2 * (14/2 + 3))] = 18k

P3 : 40psf (14) (72/2) = 20.2k

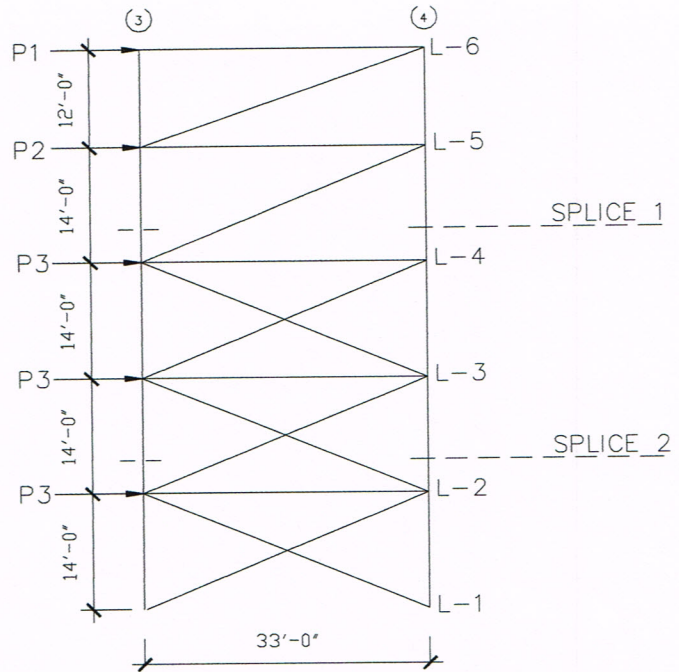

FRAMING ELEVATION
FRAMING LINE N & O

Wind Load :

Splice #1 : [(3.6^k * 22') + (18^k * 10')] / 33' = 7.9^k

Splice #2 : [(3.6^k * 50') + (18^k * 38') + (20.2^k * (24' + 10'))] / 33' = 47.0^k

Base : [(3.6^k * 68') + (18^k * 56') + (20.2^k * (18' + 28' + 42'))] / 33' = 91.8^k

ASD load cases D + L ; D + L_r; .6D + W; D + W

Splice #1 D + L ; 140.2^k © + 47.5^k © = 187.7^k ©
 D + L_r; 140.2^k © + 47.5^k © = 187.7^k © *** USE THIS LOAD ***
 .6D + W; 0.6 * 140.2^k © + 7.9^k (T) = 76.2^k ©
 .6D + W; 0.6 * 140.2^k © + 7.9^k © = 92.0^k ©
 D + W; 140.2^k © + 7.9^k (T) = 132.3^k ©
 D + W; 140.2^k © + 7.9^k © = 148.1^k ©

Splice #2 D + L ; 298.6^k © + 237.6^k © = 536.2^k © *** USE THIS LOAD ***
 D + L_r; 298.6^k © + 47.5^k © = 346.1^k ©
 .6D + W; 0.6 * 298.6^k © + 47.0^k (T) = 132.2^k ©
 .6D + W; 0.6 * 298.6^k © + 47.0^k © = 226.2^k ©
 D + W; 298.6^k © + 47.0^k (T) = 251.6^k ©
 D + W; 298.6^k © + 47.0^k © = 345.6^k ©

Base D + L ; 377.8^k © + 285.1^k © = 662.9^k © *** USE THIS LOAD ***
 D + L_r; 377.8^k © + 47.5^k © = 425.3^k ©
 .6D + W; 0.6 * 377.8^k © + 91.8^k (T) = 139.9^k ©
 .6D + W; 0.6 * 377.8^k © + 91.8^k © = 318.5^k ©
 D + W; 377.8^k © + 91.8^k (T) = 286.0^k ©
 D + W; 377.8^k © + 91.8^k © = 469.6^k ©

ASD Analysis	Splice #1	187.7 ^k @ KL=14	W14x43	Pn= 212 ^k
	Splice #2	536.2 ^k @ KL=14	W14x90	Pn= 682 ^k
	Base	662.9 ^k @ KL=14	W14x99	Pn= 751 ^k

LRFD load cases 1.2D + 1.6L + 0.5L_r ; 1.2D + 0.5L + 1.6L_r ;
 0.9D + 1.6W ; 1.2D + 1.6W + 0.5(L + L_r)

Splice #1 1.2D + 1.6L + 0.5L_r; 1.2(140.2^k ©) + 1.6(47.5^k ©) + 0.5(47.5^k ©) = 268.0^k ©
 1.2D + 0.5L + 1.6L_r; 1.2(140.2^k ©) + 0.5(47.5^k ©) + 1.6(47.5^k ©) = 268.0^k © * USE THIS LOAD *
 0.9D + 1.6W; 0.9(140.2^k ©) + 1.6(7.9^k (T)) = 113.5^k ©
 0.9D + 1.6W; 0.9(140.2^k ©) + 1.6(7.9^k ©) = 138.8^k ©
 1.2D + 1.6W + 0.5(L + L_r); 1.2(140.2^k ©) + 1.6(7.9^k (T)) + 0.5(47.5^k © + 47.5^k ©) = 203.1^k ©
 1.2D + 1.6W + 0.5(L + L_r); 1.2(140.2^k ©) + 1.6(7.9^k ©) + 0.5(47.5^k © + 47.5^k ©) = 228.4^k ©

Splice #2 1.2D + 1.6L + 0.5L_r; 1.2(298.6^k ©) + 1.6(237.6^k ©) + 0.5(47.5^k ©) = 762.2^k © *USE THIS LOAD *
 1.2D + 0.5L + 1.6L_r; 1.2(298.6^k ©) + 0.5(237.6^k ©) + 1.6(47.5^k ©) = 553.1^k ©
 0.9D + 1.6W; 0.9(298.6^k ©) + 1.6(47.0^k (T)) = 193.5^k ©
 0.9D + 1.6W; 0.9(298.6^k ©) + 1.6(47.0^k ©) = 343.94^k ©
 1.2D + 1.6W + 0.5(L + L_r); 1.2(298.6^k ©) + 1.6(47.0^k (T)) + 0.5(237.6^k © + 47.5^k ©) = 425.7^k ©
 1.2D + 1.6W + 0.5(L + L_r); 1.2(298.6^k ©) + 1.6(47.0^k ©) + 0.5(237.6^k © + 47.5^k ©) = 576.1^k ©

Base 1.2D + 1.6L + 0.5L_r; 1.2(377.8^k ©) + 1.6(285.1^k ©) + 0.5(47.5^k ©) = 933.3^k © *USE THIS LOAD *
 1.2D + 0.5L + 1.6L_r; 1.2(377.8^k ©) + 0.5(285.1^k ©) + 1.6(47.5^k ©) = 671.9^k ©
 0.9D + 1.6W; 0.9(377.8^k ©) + 1.6(91.8^k (T)) = 193.1^k ©
 0.9D + 1.6W; 0.9(377.8^k ©) + 1.6(91.8^k ©) = 486.9^k ©
 1.2D + 1.6W + 0.5(L + L_r); 1.2(377.8^k ©) + 1.6(91.8^k (T)) + 0.5(285.1^k © + 47.5^k ©) = 472.8^k ©
 1.2D + 1.6W + 0.5(L + L_r); 1.2(377.8^k ©) + 1.6(91.8^k ©) + 0.5(285.1^k © + 47.5^k ©) = 766.5^k ©

LRFD
 Splice #1 Pn = 268.0^k ©
 KL=14 W14x43

ASD
 Splice #1 Pn = 187.7^k ©
 KL=14 W14x43

Splice #2 Pn = 762.2^k ©
 KL=14 W14x82

Splice #2 Pn = 536.2^k ©
 KL=14 W14x90

Base Pn = 933.3^k ©
 KL-14 W14x90

Base Pn = 662.9^k ©
 KL=14 W14x90

Check Above Splice #1 W14x43 with KL=14'

$r_y = 1.89''$; Area = 12.6 in²; AISC Pg 1-22

$Kl/r = (1) * (14') * (12''/1') / 1.89 = 88.9$

$F_e = (\pi^2 * 29,000) / (88.9)^2 = 36.2 \text{ ksi} > .44 * (50 \text{ ksi}) = 22.0 \text{ ksi}$ **INELASTIC CAN NOT USE EULER**

$F_{cr} = (0.658^{50/36.2}) * 50 = (0.658^{1.38122}) * 50 = 28.05 \text{ ksi}$ $P_n = F_{cr} * A_g$

LRFD $\Phi_c = 0.90$

$\Phi_c * P_n$

$0.9 * 28.05 \text{ ksi} * 12.6 \text{ in}^2 = 318.1^k$

Check Required/Capacity 268/318

ASD $\Omega_c = 1.67$

P_n / Ω_c

$28.05 \text{ ksi} * 12.6 \text{ in}^2 / 1.67 = 211.6^k$

188/212

Check Above Splice #2 W14x90 with KL=14'

$r_y = 3.70''$; Area = 26.5 in²; AISC Pg 1-22

$Kl/r = (1) * (14') * (12''/1') / 3.70 = 45.4$

$F_e = (\pi^2 * 29,000) / (45.4)^2 = 138.9 \text{ ksi} > .44 * (50 \text{ ksi}) = 22.0 \text{ ksi}$ **INELASTIC CAN NOT USE EULER**

$F_{cr} = (0.658^{50/138.9}) * 50 = (0.658^{0.35997}) * 50 = 43.01 \text{ ksi}$ $P_n = F_{cr} * A_g$

LRFD $\Phi_c = 0.90$

$\Phi_c * P_n$

$0.9 * 43.01 \text{ ksi} * 26.5 \text{ in}^2 = 1025.8^k$

Check Required/Capacity 762/1026

ASD $\Omega_c = 1.67$

P_n / Ω_c

$43.01 \text{ ksi} * 26.5 \text{ in}^2 / 1.67 = 682.5^k$

536/682

Check Above Base W14x90 with KL=14'

$r_y = 3.70''$; Area = 26.5 in²; AISC Pg 1-22

$Kl/r = (1) * (14') * (12''/1') / 3.70 = 45.4$

$F_e = (\pi^2 * 29,000) / (45.4)^2 = 138.9 \text{ ksi} > .44 * (50 \text{ ksi}) = 22.0 \text{ ksi}$ **INELASTIC CAN NOT USE EULER**

$F_{cr} = (0.658^{50/138.9}) * 50 = (0.658^{0.35997}) * 50 = 43.01 \text{ ksi}$ $P_n = F_{cr} * A_g$

LRFD $\Phi_c = 0.90$

$\Phi_c * P_n$

$0.9 * 43.01 \text{ ksi} * 26.5 \text{ in}^2 = 1025.8^k$

Check Required/Capacity 933/1026

ASD $\Omega_c = 1.67$

P_n / Ω_c

$43.01 \text{ ksi} * 26.5 \text{ in}^2 / 1.67 = 682.5^k$

663/682

CONCLUSION

Interior Columns (N₃; N₄; O₃; O₄)

Above Splice #1 W14x43

Above Splice #2 to Splice #1 W14x90

$P_n = F_{cr} * Area$

Floor Beam Design for North/South Interior Beams Level 2, Level 3 & Level 4

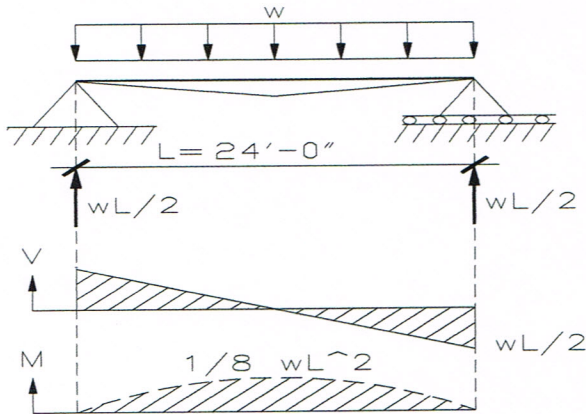

Contributory Width = $33/3 = 11$ ft

$$M_{\max} = wL^2/8, V_{\max} = wL/2, \Delta_{\max} = 5wL^4/384EI \text{ (AISC Pg 3-220)}$$

Deflection Limits, For ASD & LRFD use un-factored loads

$$\Delta_{\text{Live}} < 24 \cdot 12/360 = 0.8 \text{ in}; \Delta_{\text{Total}} < 24 \cdot 12/200 = 1.44 \text{ in}$$

LOADS

$$w_D = 100 \text{ psf} \cdot 11' = 1.1 \text{ k/LF}$$

$$w_L = 120 \text{ psf} \cdot 11' = 1.32 \text{ k/LF}$$

$$w_T = 2.42 \text{ k/LF}$$

$$w_{nD} = 1.2 \cdot 1.1 \text{ k/LF} = 1.32 \text{ k/LF}$$

$$w_{nL} = 1.6 \cdot 1.32 \text{ k/LF} = 2.11 \text{ k/LF}$$

$$w_{nT} = 3.43 \text{ k/LF}$$

$$I_{\min} = \max \text{ of } 5w_L L^4 \cdot 1728/384E \cdot \Delta_{\text{Live}} \text{ or } 5w_T L^4 \cdot 1728/384E \cdot \Delta_{\text{Total}}$$

$$I_{\min} = \max \text{ of } (5 \cdot 1.32 \text{ k/LF} \cdot 24^4 \cdot 1728) \text{ or } (5 \cdot 2.42 \text{ k/LF} \cdot 24^4 \cdot 1728)$$

$$(384 \cdot 29,000 \cdot 0.8 \text{ in}) \quad \text{or} \quad (384 \cdot 29,000 \cdot 1.44)$$

$$= \max \text{ of } (425 \text{ in}^4) \quad \text{or} \quad (433 \text{ in}^4)$$

$$I_{\min} = 433 \text{ in}^4$$

Designed as fully braced

$$M_n = M_p = ZF_y$$

LRFD

Load Case 1.2D + 1.6L

$$M_{\max} = 1/8 \cdot 3.43 \cdot 24^2 = 247.0 \text{ ft-k}$$

$$V_{\max} = 3.43 \cdot 24/2 = 41.2 \text{ k}$$

$$Z_{\text{required}} = 247 \cdot 12 \text{ in/ft} / (0.9 \cdot 50 \text{ ksi}) = 65.9 \text{ in}^3$$

$$I_{\text{required}} = 433 \text{ in}^4$$

ASD

Load Case D + L

$$M_{\max} = 1/8 \cdot 2.42 \cdot 24^2 = 174.2 \text{ ft-k}$$

$$V_{\max} = 2.42 \cdot 24/2 = 29.0 \text{ k}$$

$$Z_{\text{required}} = 174.2 \cdot 12 \text{ in/ft} \cdot 1.67 / 50 \text{ ksi} = 69.8 \text{ in}^3$$

$$I_{\text{required}} = 433 \text{ in}^4$$

$$\text{W18x35 } A=10.3, d=17.7, t_w=0.300, Z_{x-x} = 66.5 > 64, I_{x-x} = 510 > 433$$

$$\text{Check shear: LRFD } (d \cdot t_w \cdot \text{ksi}) > V_{\max} \quad ; \quad \text{ASD } (d \cdot t_w \cdot \text{ksi}/1.5) > V_{\max}$$

$$\text{LRFD } (17.7 \cdot 0.3 \cdot 50) = 265 > 41.2 \quad ; \quad \text{ASD } (17.7 \cdot 0.3 \cdot 50/1.5) = 177 > 29.0$$

Floor Beam Design for North/South Exterior Beams Level 2, Level 3 & Level 4 (Cont.)

Contributory width floor = $11/2 = 5.5'$
 Contributory height exterior walls = $14'$

$$w_D = (100\text{psf} * 5.5') + (50\text{psf} * 14') = 1.25^{k/LF}$$

$$w_L = (120\text{psf} * 5.5') = 0.66^{k/LF}$$

$$w_T = 1.91^{k/LF} < 2.42^{k/LF} \text{ (Interior)}$$

$$w_{nD} = 1.2 * 1.25^{k/LF} = 1.50^{k/LF}$$

$$w_{nL} = 1.6 * 0.66^{k/LF} = 1.06^{k/LF}$$

$$w_{nT} = 2.56^{k/LF} < 3.43^{k/LF} \text{ (Interior)}$$

Use W18x35 for both ASD and LRFD

Beam End Connections

$3/4''$ A325-N bolts

LRFD Capacity 15.9 k/bolt

ASD Capacity 10.6 k/bolt

NORTH/SOUTH BEAMS PINN CONNECTION TO EAST/WEST GIRDERS

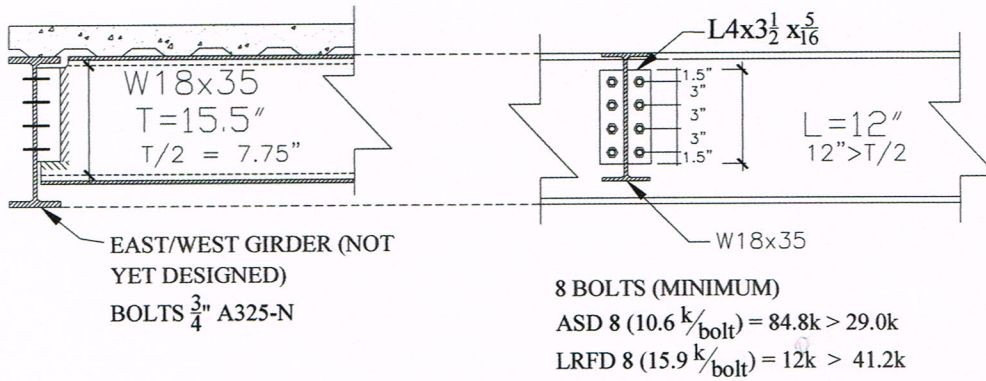

East/West Girders Interior Level 2, Level 3 & Level 4

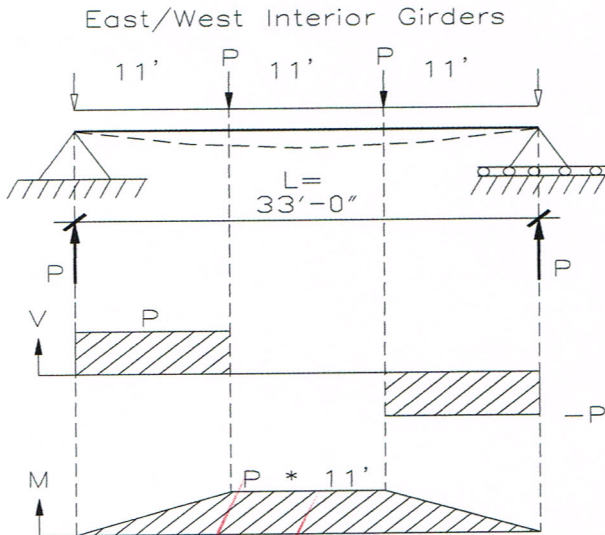

LOADS

$$P_D = 100 \text{psf} * 11' * 24' = 26.4^k$$

$$P_L = 120 \text{psf} * 11' * 24' = 31.7^k$$

$$P_T = 58.1^k$$

$$\Delta_{\text{Live}} = 33 * 12/360 = 1.1$$

$$\Delta_{\text{Total}} = 33 * 12/200 = 1.98$$

$$I_{\text{min}} = \max \text{ of } 0.036 P_L L^3 * 1728/E * \Delta_{\text{Live}} \quad \text{or} \quad 0.036 P_T L^3 * 1728/E * \Delta_{\text{Total}}$$

$$I_{\text{min}} = \max \text{ of } \frac{(0.036 * 31.7^k * 24^3 * 1728)}{(29,000 * 1.1 \text{ in})} \quad \text{or} \quad \frac{(0.036 * 58.1^k * 24^3 * 1728)}{(29,000 * 1.98)}$$

$$= \max \text{ of } (855 \text{ in}^4) \quad \text{or} \quad (870 \text{ in}^4)$$

$$I_{\text{min}} = 870 \text{ in}^4$$

$$M_{\text{max}} = P (L/3)$$

$$V_{\text{max}} = P$$

$$\Delta_{\text{max}} = 0.036 PL^3/EI \text{ (AISC Pg 3-208)}$$

LRFD

$$M_{\text{nmax}} = (1.2P_D + 1.6P_L) * 33'/3$$

$$= [1.2(26.4^k) + 1.6(31.7^k)] * 33/3 = 906.4^{\text{ft-k}}$$

$$V_{\text{nmax}} = (1.2P_D + 1.6P_L)$$

$$= [1.2(26.4^k) + 1.6(31.7^k)] = 82.4^k$$

$$Z_{\text{required}} = 906.4^{\text{ft-k}} * 12''/\text{ft} / (.9 * 50 \text{ksi}) = 242 \text{in}^3$$

$$I_{\text{required}} = 870 \text{ in}^4$$

ASD

$$M_{\text{max}} = P_T (33'/3)$$

$$= 58.1^k (33/3) = 639.1^{\text{ft-k}}$$

$$V_{\text{max}} = P_T$$

$$= 58.1^k$$

$$Z_{\text{required}} = 639.1^{\text{ft-k}} * 12''/\text{ft} * 1.67 / 50 \text{ksi} = 256 \text{in}^3$$

$$I_{\text{required}} = 870 \text{ in}^4$$

<u>W21x101</u> A=29.8, d=21.4, t _w =0.500, ;	<u>W21x111</u> A=32.7, d=21.5, t _w =0.550,
Z _{x-x} = 253 > 242, I _{x-x} = 2420 > 870 ;	Z _{x-x} = 279 > 256, I _{x-x} = 2670 > 870
Check shear: LRFD (d * t _w * ksi) > V _{nmax} ;	ASD (d * t _w * ksi/1.5) > V _{max}
(21.4 * 0.5 * 50) = 535 > 82.4 ;	(21.5 * 0.55 * 50/1.5) = 394 > 58.1

East/West Girders Exteriors Level 2, Level 3 & Level 4

Contributory width floor = 24'/2 = 12'
 Contributory height exterior walls = 14' * 11'

$$\begin{aligned}
 P_D &= (100\text{psf} * 12' * 11') + (50\text{psf} * 14' * 11') = 20.9^k & P_{nD} &= 1.2 * 20.9^k = 25.1^k \\
 P_L &= (120\text{psf} * 12' * 11') = 15.8^k & P_{nL} &= 1.6 * 15.8^k = 25.3^k \\
 P_T &= 36.7^k & P_{nT} &= 50.4^k
 \end{aligned}$$

$$\begin{aligned}
 I_{min} &= \max \text{ of } 0.036 P_L L^3 * 1728/E * \Delta_{Live} \quad \text{or} \quad 0.036 P_T L^3 * 1728/E * \Delta_{Total} \\
 I_{min} &= \max \text{ of } \frac{(0.036 * 15.8^k * 24^3 * 1728)}{(29,000 * 1.1 \text{ in})} \quad \text{or} \quad \frac{(0.036 * 36.7^k * 24^3 * 1728)}{(29,000 * 1.98)} \\
 &= \max \text{ of } (425.9 \text{ in}^4) \quad \text{or} \quad (549.6 \text{ in}^4) \\
 I_{min} &= 549.6 \text{ in}^4
 \end{aligned}$$

$$\begin{aligned}
 M_{max} &= P (L/3) \\
 V_{max} &= P \\
 \Delta_{max} &= 0.036 PL^3/EI \text{ (AISC Pg 3-208)}
 \end{aligned}$$

LRFD

$$\begin{aligned}
 M_{nmax} &= (1.2P_D + 1.6P_L) * 33'/3 \\
 &= [25.1^k + 25.3^k] * 11' = 554.4^{\text{ft-k}} \\
 V_{nmax} &= (1.2P_D + 1.6P_L) = 50.4^k \\
 Z_{required} &= 554.4^{\text{ft-k}} * 12'/\text{ft} / (.9 * 50\text{ksi}) = 147.8 \text{ in}^3 \\
 I_{required} &= 549.6 \text{ in}^4
 \end{aligned}$$

ASD

$$\begin{aligned}
 M_{max} &= P_T (33'/3) \\
 &= 36.7^k (11') = 403.7^{\text{ft-k}} \\
 V_{max} &= P_T = 36.7^k \\
 Z_{required} &= 403.7^{\text{ft-k}} * 12'/\text{ft} * 1.67 / 50\text{ksi} = 161.8 \text{ in}^3 \\
 I_{required} &= 549.6 \text{ in}^4
 \end{aligned}$$

W21x68 A=20.0, d=21.1, t_w=0.4300,
 Z_{x-x} = 160 > 147.8, I_{x-x} = 1480 > 549.6
 Check shear: LRFD (d * t_w * ksi) > V_{nmax}
 LRFD (21.1 * 0.43 * 50) = 454 > 50.4 ;

W21x73 A=21.5, d=21.2, t_w=0.455,
 Z_{x-x} = 172 > 161.8, I_{x-x} = 1600 > 549.6
 ASD (d * t_w * ksi/1.5) > V_{max}
 ASD (21.2 * 0.455 * 50/1.5) = 321 > 36.7

RIGID FRAME DESIGN @ N₂ - O₂ & N₅ - O₅

Resisting North/South Wind Loads & Providing North/South Stability

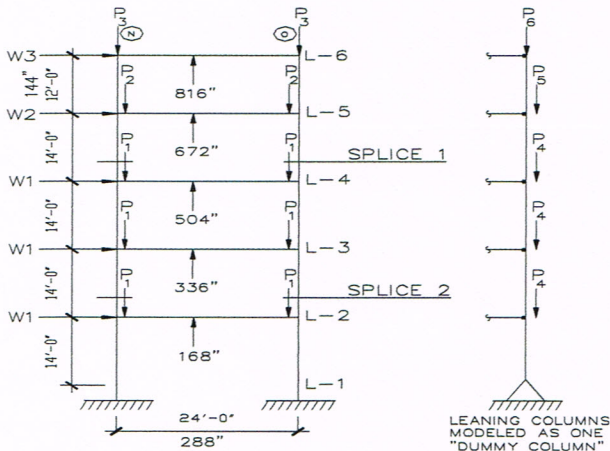

P-loads – Lump all vertical loads at end nodes, even though some load goes directly to rigid frame beams.

LRFD Load Case 1.6D + 1.2Wind + 0.5L

E = 29,000 ksi

Wind Loads

$W_1 = 1.6 * \text{Wind psf} [\frac{1}{2} \text{ length of building} * \text{height of exterior wall supported by each floor}]$

$$W_1 = 1.6 * 40\text{psf} [(\frac{1}{2}(5 * 33' + 2')) * 14']$$

$$= 1.6 * 40\text{psf} [(\frac{1}{2} * 167') * 14'] = 1.6 * 40\text{psf} * 1169\text{ft}^2 = \underline{74.8^k}$$

$W_2 = 1.6 * \text{Wind psf} [\frac{1}{2} (\text{length of building} * \frac{1}{2} \text{ height of exterior wall supported by each floor} + \text{parapet}) + (\frac{1}{2} \text{ length of the penthouse} + 1') * \frac{1}{2} \text{ height of exterior wall penthouse}]$

$$W_2 = 1.6 * 40\text{psf} [(\frac{1}{2}(5 * 33' + 2')) * (14/2' + 3')] + [\frac{1}{2}(3 * 33' + 2') * 12/2']$$

$$W_2 = 1.6 * 40\text{psf} [(\frac{1}{2} * 167') * 10'] + [(50.5' * 6')] = 1.6 * 40\text{psf} [835\text{ft}^2 + 303\text{ft}^2] = \underline{72.8^k}$$

$W_3 = 1.6 * \text{Wind psf} [\frac{1}{2} \text{ length of the penthouse} + 1') * \frac{1}{2} \text{ height of exterior wall penthouse} + 1' \text{ parapet}]$

$$W_3 = 1.6 * 40\text{psf} [\frac{1}{2}(3 * 33' + 2') * (12/2 + 1')]$$

$$W_3 = 1.6 * 40\text{psf} [50.5' * 7'] = 1.6 * 40\text{psf} * 353.5\text{ft}^2 = \underline{22.6^k}$$

Vertical Loads from 1.2D + 0.5L

$$P_1 = 1.2 * [24' * 33' * 100\text{psf}] + 0.5[24' * 33' * 120\text{psf}]$$

$$= 95.04^k + 47.52^k = \underline{142.56^k}$$

$$P_2 = 1.2[(24' * 33' * 100\text{psf}) + (6'(12' + 16.5') * 50\text{psf})] + 0.5 [24' * 33' * 60\text{psf}]$$

$$= 1.2 [79.2^k + 8.55^k] + 0.5 [47.5^k] = 105.3^k + 23.7^k = \underline{129.0^k}$$

$$P_3 = 1.2 [(12' * 16.5' * 100\text{psf}) + ((6'+1')(12' + 16.5') * 50\text{psf})] + 0.5 [12' * 16.5' * 60\text{psf}]$$

$$= 1.2 [19.8^k + 10.0^k] + 0.5 [11.9^k] = 35.76^k + 5.95^k = \underline{41.7^k}$$

All factored load at Level 2, 3, or 4 for 50% of Bldg not directly applied to rigid frame as P₄. Cut the building in two symmetrical halves North to South, each half of building is supported by rigid frame in that area: 72' x 82.5' = 5,940 ft², with perimeter : (2 * 82.5') + 72' = 237'; Penthouse dimensions 24' x 49.5' = 1,188 ft², with perimeter : (2 * 49.5') + 24' = 123'

$$P_4 = 1.2 [(5,940 \text{ ft}^2 * 100 \text{ psf}) + (14' * 237' * 50\text{psf})] + 0.5 [5,940 \text{ ft}^2 * 120 \text{ psf}] - 2 * P_1$$

$$= 1.2 [594^k + 165.9^k] + 0.5 [712.8^k] - 2 [142.6^k] = 911.88^k + 356.4^k - 285.2^k = \underline{983.1^k}$$

$$P_5 = 1.2[(5,940 \text{ ft}^2 * 100 \text{ psf}) + ((7' + 3') * 237' * 50\text{psf}) + (6' * 123' * 50\text{psf})] + 0.5[5,940 \text{ ft}^2 * 60 \text{ psf}] - 2 * P_2$$

$$= 1.2 [594^k + 118.5^k + 36.9^k] + 0.5 [356.4^k] - 2 [129^k] = 899.3^k + 178.2^k - 258.0^k = \underline{819.5^k}$$

$$P_6 = 1.2[(1,188 \text{ ft}^2 * 100 \text{ psf}) + ((6' + 1') * 123' * 50\text{psf})] + 0.5[1,188 \text{ ft}^2 * 60 \text{ psf}] - 2 * P_3$$

$$= 1.2 [118.8^k + 43.0^k] + 0.5 [71.3^k] - 2 [41.7^k] = 194.2^k + 35.7^k - 83.4^k = \underline{146.5^k}$$

Preliminary Design – Portal Method, ignoring P-Δ

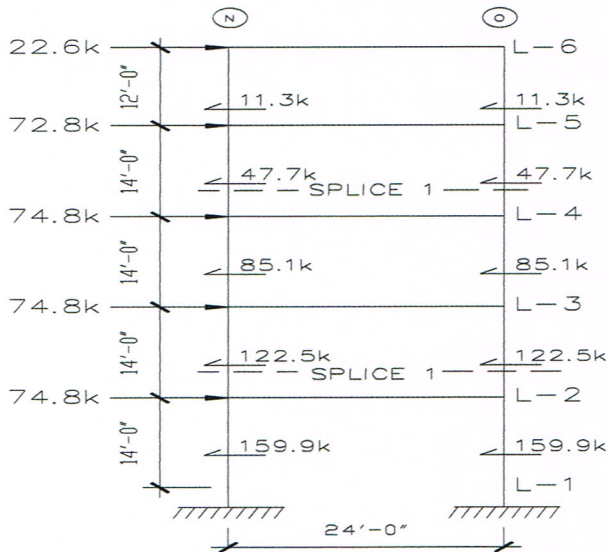

L₅ – L₆ Columns and L₆ Beam

$$M = 12'/2 * 11.3^k = 67.8^{ft-k}$$

L₄ – L₅ Columns

$$M = 14'/2 * 47.7^k = 333.9^{ft-k}$$

L₅ Beam

$$333.9^{ft-k} + 67.8^{ft-k} = 401.7^{ft-k}$$

L₃ – L₄ Columns

$$M = 14'/2 * 85.1^k = 595.7^{ft-k}$$

L₄ Beam

$$595.7^{ft-k} + 333.9^{ft-k} = 929.7^{ft-k}$$

L₂ – L₃ Columns

$$M = 14'/2 * 122.5^k = 857.5^{ft-k}$$

L₃ Beam

$$857.5^{ft-k} + 595.7^{ft-k} = 1453.2^{ft-k}$$

L₁ – L₂ Columns

$$M = 14'/2 * 159.9^k = 1119.3^{ft-k}$$

L₂ Beam

$$1119.3^{ft-k} + 857.5^{ft-k} = 1976.8^{ft-k}$$

Rigid Frame Beam Selection

Ignoring Axial Force and P-Δ ; Assumed fully braced

$$L_6 Z_{required} = (67.8^{ft-k}) * (12''/ft) / (.9 * 50ksi) = 18.1 \text{ in}^3$$

$$L_5 Z_{required} = (401.7^{ft-k}) * (12''/ft) / (.9 * 50ksi) = 107.1 \text{ in}^3$$

$$L_4 Z_{required} = (929.7^{ft-k}) * (12''/ft) / (.9 * 50ksi) = 247.9 \text{ in}^3$$

$$L_3 Z_{required} = (1453.2^{ft-k}) * (12''/ft) / (.9 * 50ksi) = 387.5 \text{ in}^3$$

$$L_2 Z_{required} = (1976.8^{ft-k}) * (12''/ft) / (.9 * 50ksi) = 527.1 \text{ in}^3$$

$$W14x68, Z=115 \text{ in}^3$$

$$W21x83, Z=196 \text{ in}^3$$

$$W21x132, Z=333 \text{ in}^3$$

$$W30x148, Z=500 \text{ in}^3$$

$$W30x191, Z=675 \text{ in}^3$$

In addition to the strength requirements limit the L₆ lateral movement to height/150 due to factored loads, including P-Δ, $816'' / 150 = 5.44''$

Rigid Frame Preliminary Column Design

Below Splice #2 to Column Base (L₁ - L₂)

$$M_{\text{prelim}} = 1119.3^{\text{ft-k}}$$

Forces at base of L₁ due to Wind = [W₁ * (distance from base to Level 2 + Level 3 + Level 4) + (W₂ * distance from base to Level 5) + (W₃ * distance from base to Level 6)] / distance between rigid frame columns

$$= [74.8^{\text{k}} * (14' + 28' + 42') + (72.8^{\text{k}} * 56') + (22.6^{\text{k}} * 68')] / 24'$$
$$= [6283.2^{\text{ft-k}} + 4076.8^{\text{ft-k}} + 1536.8^{\text{ft-k}}] / 24' = \underline{495.7^{\text{k}}} \text{ (due to 1.6W)}$$

P_{Down} = 3P₁ + P₂ + P₃ + Axial force from wind overturning

$$P_{\text{Down}} = 3(142.56^{\text{k}}) + 129.0^{\text{k}} + 41.7^{\text{k}} + 495.7^{\text{k}} = \underline{1094.1^{\text{k}}}$$

(Note: P_{min} = .9P_{Down} = 984.7^k > 495.5^k therefore No Uplift)

At this point assuming M_n = M_{prelim}

Using this Moment only Z_{required} = (1119.3^{ft-k} * 12"/ft) / (.9 * 50ksi) = 298.9 in³

Start with W24x192, A = 56.3 in², I = 6260 in⁴, r_y = 3.07", r_x = 10.5", Z = 559 in³

Assuming the weak axis for buckling governs

(to be check later)

$$Kl/r = (1 * 14' * 12"/ft) / 3.07" = 54.7$$

$$F_e = (\pi^2 * 29,000) / (54.7)^2 = 95.7 \text{ ksi} > .44 * (50 \text{ ksi}) = 22 \text{ ksi}$$

INELASTIC CAN NOT USE EULER

$$F_{cr} = (0.658^{50/95.7}) * 50 = (0.658^{0.52247}) * 50 = 40.18 \text{ ksi}$$

LRFD $\Phi_c = 0.90$

$$\Phi_c * P_n \quad (P_n = F_{cr} * A_g)$$

$$0.9 * 40.18 \text{ ksi} * 56.3 \text{ in}^2 = 2035.9^{\text{k}}$$

$$\text{Check Required/Capacity} \quad 1094.1^{\text{k}} / 2035.9^{\text{k}} = 0.537$$

$$M_u / \Phi M_n = (1119.3^{\text{ft-k}} * 12"/ft) / (.9 * 559 \text{ in}^3 * 50 \text{ ksi}) = 0.534$$

(Not including P- Δ 0.537 + 0.534 = 1.07 > 1 **Not OK!**)

$$1.07 * 192 \text{ #/ft} = 205.6 \text{ #/ft}$$

Try W24x229, A = 67.2 in², I = 7650 in⁴, r_y = 3.11", r_x = 10.7", Z = 675 in³

$$Kl/r = (1 * 14' * 12"/ft) / 3.11" = 54.0$$

$$F_e = (\pi^2 * 29,000) / (54.0)^2 = 98.1 \text{ ksi} > .44 * (50 \text{ ksi}) = 22 \text{ ksi}$$

STILL INELASTIC CAN NOT USE EULER

$$F_{cr} = (0.658^{50/98.1}) * 50 = (0.658^{0.5096}) * 50 = 40.39 \text{ ksi}$$

LRFD $\Phi_c = 0.90$

$$\Phi_c * P_n \quad (P_n = F_{cr} * A_g)$$

$$0.9 * 40.39 \text{ ksi} * 67.2 \text{ in}^2 = 2443.1^{\text{k}}$$

$$\text{Check Required/Capacity} \quad 1094.1^{\text{k}} / 2443.1^{\text{k}} = 0.448$$

$$M_u / \Phi M_n = (1119.3^{\text{ft-k}} * 12"/ft) / (.9 * 675 \text{ in}^3 * 50 \text{ ksi}) = 0.442$$

(Not including P- Δ 0.448 + 0.442 = 0.89 < 1 **OK!**)

For Preliminary Design from Base to Splice 2 use W24x229, A = 67.2 in², I = 7650 in⁴, r_y = 3.11", r_x = 10.7", Z = 675 in³

Splice #2 to Splice #1 (L₂ – L₃)

$$M_{L_2-L_3} \text{ Columns} = 857.5^{\text{ft-k}};$$

Forces at Splice #2 due to Wind = $[W_1 * (\text{distance from Splice \#2 to Level 3} + \text{Level 4}) + (W_2 * \text{distance from Splice \#2 to Level 5}) + (W_3 * \text{distance from Splice \#2 to Level 6})]$ / distance between rigid frame columns

$$= [74.8^{\text{k}} * (7' + 21') + (72.8^{\text{k}} * 35') + (22.6^{\text{k}} * 49')] / 24'$$
$$= [2094.4^{\text{ft-k}} + 2548.0^{\text{ft-k}} + 1107.4^{\text{ft-k}}] / 24' = 239.6^{\text{k}} \text{ (due to 1.6W)}$$

$P_{\text{Down}} = 2P_1 + P_2 + P_3 + \text{Axial force from wind overturning}$

$$P_{\text{Down}} = 2(142.56^{\text{k}}) + 129.0^{\text{k}} + 41.7^{\text{k}} + 239.6^{\text{k}} = \underline{695.4^{\text{k}}}$$

(Note: $P_{\text{min}} = .9P_{\text{Down}} = 625.9^{\text{k}} > 239.6^{\text{k}}$ therefore No Uplift)

At this point assuming $M_n = M_{\text{prelim}}$

$$\text{Using this Moment only } Z_{\text{required}} = (857.5^{\text{ft-k}} * 12''/\text{ft}) / (.9 * 50\text{ksi}) = 228.7 \text{ in}^3$$

Start with W24x146, $A = 43.0 \text{ in}^2$, $I = 4580 \text{ in}^4$, $r_y = 3.01''$, $r_x = 10.3''$, $Z = 418 \text{ in}^3$

Assuming the weak axis for buckling governs (to be check later)

$$Kl/r = (1 * 14' * 12''/\text{ft}) / 3.01'' = 55.8$$

$$F_e = (\pi^2 * 29,000) / (55.8)^2 = 91.9 \text{ ksi} > .44*(50 \text{ ksi}) = 22.0 \text{ ksi} \quad \underline{\text{INELASTIC CAN NOT USE EULER}}$$

$$F_{\text{cr}} = (0.658^{50/91.9}) * 50 = (0.658^{0.54407}) * 50 = 39.82 \text{ ksi}$$

LRFD $\Phi_c = 0.90$

$$\Phi_c * P_n \quad (P_n = F_{\text{cr}} * A_g)$$

$$0.9 * 39.82 \text{ ksi} * 43.0 \text{ in}^2 = 1541.0^{\text{k}}$$

$$\text{Check Required/Capacity} \quad 695.4^{\text{k}} / 1541.0^{\text{k}} = 0.451$$

$$M_u / \Phi M_n = (857.5^{\text{ft-k}} * 12''/\text{ft}) / (.9 * 418 \text{ in}^3 * 50\text{ksi}) = 0.547$$

(Not including $P-\Delta$ $0.451 + 0.442 = 0.998 < 1$ OK!)

For Preliminary Design from Splice #2 to Splice #1 use W24x146, $A = 43.0 \text{ in}^2$, $I = 4580 \text{ in}^4$, $r_y = 3.01''$, $r_x = 10.3''$, $Z = 418 \text{ in}^3$

Splice #1 to Top (L₄ – L₅)

$$M_{L_4-L_5} \text{ Columns} = 333.9^{\text{ft-k}};$$

Forces at Splice #1 due to Wind = $[(W_2 * \text{distance from Splice \#1 to Level 5}) + (W_3 * \text{distance from Splice \#1 to Level 6})]$ / distance between rigid frame columns

$$= [(72.8^{\text{k}} * 7') + (22.6^{\text{k}} * 19')] / 24'$$
$$= [551.6^{\text{ft-k}} + 429.4^{\text{ft-k}}] / 24' = 40.9^{\text{k}} \text{ (due to 1.6W)}$$

$P_{\text{Down}} = P_2 + P_3 + \text{Axial force from wind overturning}$

$$P_{\text{Down}} = 129.0^{\text{k}} + 41.7^{\text{k}} + 40.9^{\text{k}} = \underline{211.6^{\text{k}}}$$

(Note: $P_{\text{min}} = .9P_{\text{Down}} = 190.44^{\text{k}} > 40.9^{\text{k}}$ therefore No Uplift)

At this point assuming $M_n = M_{\text{prelim}}$

Using this Moment only $Z_{required} = (333.9^{ft-k} * 12''/ft) / (.9 * 50ksi) = 89.04 in^3$

Start with W24x76, $A = 22.4 in^2$, $I = 2100 in^4$, $r_y = 1.92''$, $r_x = 9.69''$, $Z = 200 in^3$

Assuming the weak axis for buckling governs (to be check later)

$Kl/r = (1 * 14' * 12''/ft) / 1.92'' = 87.5$

$F_e = (\pi^2 * 29,000) / (87.5)^2 = 37.38 ksi > .44 * (50 ksi) = 22.0 ksi$ **INELASTIC CAN NOT USE EULER**

$F_{cr} = (0.658^{50/37.38}) * 50 = (0.658^{1.3376}) * 50 = 28.56 ksi$

LRFD $\Phi_c = 0.90$

$\Phi_c * P_n$ ($P_n = F_{cr} * A_g$)

$0.9 * 28.56 ksi * 22.4 in^2 = 575.9^k$

Check Required/Capacity $211.6^k / 575.9^k = 0.367$

$M_u / \Phi M_n = (333.9^{ft-k} * 12''/ft) / (.9 * 200 in^3 * 50ksi) = 0.445$

(Not including P- Δ $0.367 + 0.445 = 0.812 < 1$ OK!)

For Preliminary Design from Splice #1 to Top use W24x76, $A = 22.4 in^2$, $I = 2100 in^4$, $r_y = 1.92''$, $r_x = 9.69''$, $Z = 200 in^3$

Summary of Preliminary Design for computer model :

Computer Model – 18 nodes (joints), 25 members, 15 nodes loaded, none pin ended.

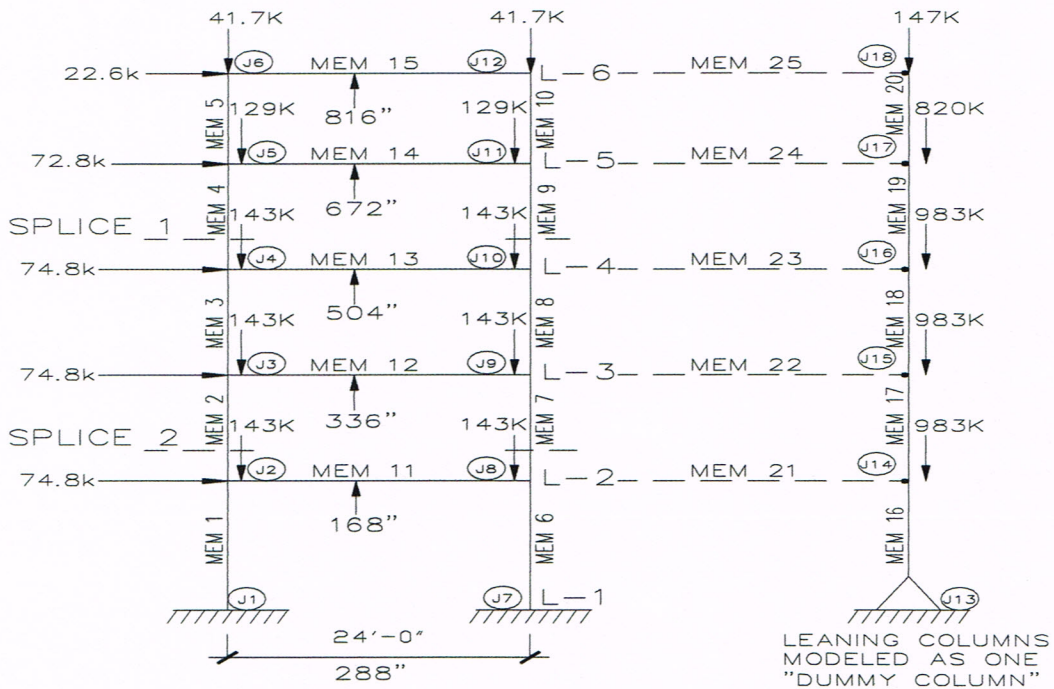

Test the following use of beams and columns in the PLFNL2 program.

$L_6 Z_{required}$ use W14x68, $Z=115 \text{ in}^3$, $A= 20.0 \text{ in}^2$, $I= 722 \text{ in}^4$
 $L_5 Z_{required}$ use W21x83, $Z=196 \text{ in}^3$, $A= 24.3 \text{ in}^2$, $I=1830 \text{ in}^4$
 $L_4 Z_{required}$ use W21x132, $Z=333 \text{ in}^3$, $A= 38.8 \text{ in}^2$, $I=3220 \text{ in}^4$
 $L_3 Z_{required}$ use W30x148, $Z=500 \text{ in}^3$, $A= 43.5 \text{ in}^2$, $I=6680 \text{ in}^4$
 $L_2 Z_{required}$ use W30x191, $Z=675 \text{ in}^3$, $A= 56.3 \text{ in}^2$, $I=9200 \text{ in}^4$
 Splice #1 to top – W24x76, $Z = 200 \text{ in}^3$, $A= 22.4 \text{ in}^2$, $I = 2100 \text{ in}^4$
 Splice #2 to Splice #1 --W24x146, $Z = 418 \text{ in}^3$, $A=43.0 \text{ in}^2$, $I = 4580 \text{ in}^4$
 Base to Splice #1 – W24x229, $Z = 675 \text{ in}^3$, $A= 67.2 \text{ in}^2$, $I = 7650 \text{ in}^4$

In addition to the strength requirements limit the L_6 lateral movement to height/150 due to factored loads, including P- Δ , $816'' / 150 = 5.44''$ Computer model calculated $4.77''$ on Joints 6, 12, & 18 O.K.

PLFNL2 OUTPUT:

NUMBER OF JOINTS = 18
 NUMBER OF MEMBERS = 25
 NUMBER OF JOINTS WITH APPLIED LOAD(S) = 15
 MODULUS OF ELASTICITY = 0.290E+05
 NUMBER OF PIN END MEMBERS = 0 (-1 INDICATES TRUSS)
 NPD= 1 (1 MEANS CALCULATE P-DELTA EFFECTS)

JOINT	X	Y	SPRING CONSTANTS		
			SX	SY	SRZ
1	0.0000E+00	0.0000E+00	0.100E+31	0.100E+31	0.100E+31
2	0.0000E+00	0.1680E+03	0.000E+00	0.000E+00	0.000E+00
3	0.0000E+00	0.3360E+03	0.000E+00	0.000E+00	0.000E+00
4	0.0000E+00	0.5040E+03	0.000E+00	0.000E+00	0.000E+00
5	0.0000E+00	0.6720E+03	0.000E+00	0.000E+00	0.000E+00
6	0.0000E+00	0.8160E+03	0.000E+00	0.000E+00	0.000E+00
7	0.2880E+03	0.0000E+00	0.100E+31	0.100E+31	0.100E+31
8	0.2880E+03	0.1680E+03	0.000E+00	0.000E+00	0.000E+00
9	0.2880E+03	0.3360E+03	0.000E+00	0.000E+00	0.000E+00
10	0.2880E+03	0.5040E+03	0.000E+00	0.000E+00	0.000E+00
11	0.2880E+03	0.6720E+03	0.000E+00	0.000E+00	0.000E+00
12	0.2880E+03	0.8160E+03	0.000E+00	0.000E+00	0.000E+00
13	0.4000E+03	0.0000E+00	0.100E+31	0.100E+31	0.000E+00
14	0.4000E+03	0.1680E+03	0.000E+00	0.000E+00	0.000E+00
15	0.4000E+03	0.3360E+03	0.000E+00	0.000E+00	0.000E+00
16	0.4000E+03	0.5040E+03	0.000E+00	0.000E+00	0.000E+00
17	0.4000E+03	0.6720E+03	0.000E+00	0.000E+00	0.000E+00
18	0.4000E+03	0.8160E+03	0.000E+00	0.000E+00	0.000E+00

MEMBER	J NODE	K NODE	AREA	INERTIA
1	1	2	0.672E+02	0.765E+04
2	2	3	0.430E+02	0.458E+04
3	3	4	0.430E+02	0.458E+04
4	4	5	0.224E+02	0.210E+04
5	5	6	0.224E+02	0.210E+04
6	7	8	0.672E+02	0.765E+04
7	8	9	0.430E+02	0.458E+04
8	9	10	0.430E+02	0.458E+04
9	10	11	0.224E+02	0.210E+04
10	11	12	0.224E+02	0.210E+04
11	2	8	0.563E+02	0.920E+04
12	3	9	0.435E+02	0.668E+04
13	4	10	0.388E+02	0.322E+04
14	5	11	0.243E+02	0.183E+04
15	6	12	0.200E+02	0.722E+03
16	13	14	-0.100E+03	0.100E+01
17	14	15	-0.100E+03	0.100E+01
18	15	16	-0.100E+03	0.100E+01
19	16	17	-0.100E+03	0.100E+01
20	17	18	-0.100E+03	0.100E+01
21	8	14	-0.100E+03	0.100E+01
22	9	15	-0.100E+03	0.100E+01
23	10	16	-0.100E+03	0.100E+01
24	11	17	-0.100E+03	0.100E+01
25	12	18	-0.100E+03	0.100E+01

MEMBER LOADS

MEMBER W AT J W AT K P1 D1 P2 D2 P3 D3

JOINT	XFORCE	YFORCE	ZMOM
2	0.748E+02	-0.143E+03	0.000E+00
3	0.748E+02	-0.143E+03	0.000E+00
4	0.748E+02	-0.143E+03	0.000E+00
5	0.728E+02	-0.129E+03	0.000E+00
6	0.226E+02	-0.417E+02	0.000E+00
8	0.000E+00	-0.143E+03	0.000E+00
9	0.000E+00	-0.143E+03	0.000E+00
10	0.000E+00	-0.143E+03	0.000E+00
11	0.000E+00	-0.129E+03	0.000E+00
12	0.000E+00	-0.417E+02	0.000E+00
14	0.000E+00	-0.983E+03	0.000E+00
15	0.000E+00	-0.983E+03	0.000E+00
16	0.000E+00	-0.983E+03	0.000E+00
17	0.000E+00	-0.820E+03	0.000E+00
18	0.000E+00	-0.147E+03	0.000E+00

OUTPUT NOT INCLUDING P-DELTA EFFECTS

JOINT DISPLACEMENTS AND REACTIONS

JT	X DISPL	Y DISPL	Z ROT	X REACT	Y REACT	ZM REACT
1	0.161D-27	-0.232D-27	-0.185D-25	-0.161E+03	0.232E+03	0.185E+05
2	0.602D+00	-0.200D-01	-0.376D-02	0.000E+00	0.000E+00	0.000E+00
3	0.168D+01	-0.502D-01	-0.475D-02	0.000E+00	0.000E+00	0.000E+00
4	0.281D+01	-0.775D-01	-0.572D-02	0.000E+00	0.000E+00	0.000E+00
5	0.401D+01	-0.111D+00	-0.481D-02	0.000E+00	0.000E+00	0.000E+00
6	<u>0.466D+01</u>	-0.118D+00	-0.360D-02	0.000E+00	0.000E+00	0.000E+00
7	0.159D-27	-0.967D-27	-0.183D-25	-0.159E+03	0.967E+03	0.183E+05
8	0.596D+00	-0.834D-01	-0.372D-02	0.000E+00	0.000E+00	0.000E+00
9	0.167D+01	-0.176D+00	-0.475D-02	0.000E+00	0.000E+00	0.000E+00
10	0.280D+01	-0.233D+00	-0.570D-02	0.000E+00	0.000E+00	0.000E+00
11	0.400D+01	-0.288D+00	-0.482D-02	0.000E+00	0.000E+00	0.000E+00
12	0.465D+01	-0.299D+00	-0.368D-02	0.000E+00	0.000E+00	0.000E+00
13	0.145D-32	-0.392D-26	-0.378D-02	-0.145E-02	0.392E+04	0.000E+00
14	0.596D+00	-0.227D+00	-0.308D-02	0.000E+00	0.000E+00	0.000E+00
15	0.167D+01	-0.397D+00	-0.473D-02	0.000E+00	0.000E+00	0.000E+00
16	0.280D+01	-0.510D+00	-0.498D-02	0.000E+00	0.000E+00	0.000E+00
17	0.400D+01	-0.566D+00	-0.446D-02	0.000E+00	0.000E+00	0.000E+00
18	0.465D+01	-0.573D+00	-0.306D-02	0.000E+00	0.000E+00	0.000E+00

MEMBER END ACTIONS

MEMBER	J	K	AX J	SHR J	MOM J	AX K	SHR K	MOM K
1	1	2	0.232E+03	0.161E+03	0.185E+05	-0.232E+03	-0.161E+03	0.855E+04
2	2	3	0.225E+03	0.122E+03	0.111E+05	-0.225E+03	-0.122E+03	0.949E+04
3	3	4	0.202E+03	0.850E+02	0.791E+04	-0.202E+03	-0.850E+02	0.637E+04
4	4	5	0.129E+03	0.480E+02	0.370E+04	-0.129E+03	-0.480E+02	0.436E+04
5	5	6	0.326E+02	0.110E+02	0.278E+03	-0.326E+02	-0.110E+02	0.131E+04
6	7	8	0.967E+03	0.159E+03	0.183E+05	-0.967E+03	-0.159E+03	0.843E+04
7	8	9	0.689E+03	0.123E+03	0.111E+05	-0.689E+03	-0.123E+03	0.949E+04
8	9	10	0.425E+03	0.852E+02	0.791E+04	-0.425E+03	-0.852E+02	0.640E+04
9	10	11	0.212E+03	0.474E+02	0.366E+04	-0.212E+03	-0.474E+02	0.430E+04
10	11	12	0.508E+02	0.116E+02	0.350E+03	-0.508E+02	-0.116E+02	0.132E+04
11	2	8	0.363E+02	-0.136E+03	-0.196E+05	-0.363E+02	0.136E+03	-0.195E+05
12	3	9	0.374E+02	-0.121E+03	-0.174E+05	-0.374E+02	0.121E+03	-0.174E+05
13	4	10	0.378E+02	-0.699E+02	-0.101E+05	-0.378E+02	0.699E+02	-0.101E+05
14	5	11	0.358E+02	-0.322E+02	-0.464E+04	-0.358E+02	0.322E+02	-0.465E+04
15	6	12	0.116E+02	-0.911E+01	-0.131E+04	-0.116E+02	0.911E+01	-0.132E+04
16	13	14	0.392E+04	0.145E-02	0.341E-15	-0.392E+04	-0.145E-02	0.244E+00
17	14	15	0.293E+04	0.309E-01	0.288E+01	-0.293E+04	-0.309E-01	0.231E+01
18	15	16	0.195E+04	0.232E-01	0.199E+01	-0.195E+04	-0.232E-01	0.190E+01
19	16	17	0.967E+03	0.293E-01	0.237E+01	-0.967E+03	-0.293E-01	0.255E+01
20	17	18	0.147E+03	0.138E-01	0.710E+00	-0.147E+03	-0.138E-01	0.127E+01
21	8	14	-0.294E-01	-0.588E-01	-0.346E+01	0.294E-01	0.588E-01	-0.312E+01
22	9	15	0.770E-02	-0.768E-01	-0.431E+01	-0.770E-02	0.768E-01	-0.430E+01
23	10	16	-0.610E-02	-0.797E-01	-0.465E+01	0.610E-02	0.797E-01	-0.427E+01
24	11	17	0.155E-01	-0.599E-01	-0.345E+01	-0.155E-01	0.599E-01	-0.326E+01
25	12	18	0.138E-01	-0.256E-01	-0.159E+01	-0.138E-01	0.256E-01	-0.127E+01

OUTPUT INCLUDING P-DELTA EFFECTS

NUMBER OF CYCLES= 2

JOINT DISPLACEMENTS AND REACTIONS

JT	X DISPL	Y DISPL	Z ROT	X REACT	Y REACT	ZM REACT
1	0.162D-27	-0.223D-27	-0.188D-25	-0.162E+03	0.223E+03	0.188E+05
2	0.613D+00	-0.192D-01	-0.384D-02	0.000E+00	0.000E+00	0.000E+00
3	0.172D+01	-0.487D-01	-0.487D-02	0.000E+00	0.000E+00	0.000E+00
4	0.288D+01	-0.756D-01	-0.587D-02	0.000E+00	0.000E+00	0.000E+00
5	0.411D+01	-0.109D+00	-0.493D-02	0.000E+00	0.000E+00	0.000E+00
6	0.477D+01	-0.116D+00	-0.368D-02	0.000E+00	0.000E+00	0.000E+00
7	0.157D-27	-0.976D-27	-0.185D-25	-0.157E+03	0.976E+03	0.185E+05
8	0.607D+00	-0.841D-01	-0.380D-02	0.000E+00	0.000E+00	0.000E+00
9	0.171D+01	-0.178D+00	-0.486D-02	0.000E+00	0.000E+00	0.000E+00
10	0.287D+01	-0.235D+00	-0.585D-02	0.000E+00	0.000E+00	0.000E+00
11	0.409D+01	-0.290D+00	-0.494D-02	0.000E+00	0.000E+00	0.000E+00
12	0.477D+01	-0.302D+00	-0.376D-02	0.000E+00	0.000E+00	0.000E+00
13	0.149D-32	-0.392D-26	-0.385D-02	-0.149E-02	0.392E+04	0.000E+00
14	0.607D+00	-0.227D+00	-0.313D-02	0.000E+00	0.000E+00	0.000E+00
15	0.171D+01	-0.397D+00	-0.482D-02	0.000E+00	0.000E+00	0.000E+00
16	0.287D+01	-0.510D+00	-0.506D-02	0.000E+00	0.000E+00	0.000E+00
17	0.409D+01	-0.566D+00	-0.453D-02	0.000E+00	0.000E+00	0.000E+00
18	0.477D+01	-0.573D+00	-0.307D-02	0.000E+00	0.000E+00	0.000E+00

MEMBER END ACTIONS

MEMBER	J	K	AX J	SHR J	MOM J	AX K	SHR K	MOM K
1	1	2	0.223E+03	0.162E+03	0.188E+05	-0.223E+03	-0.162E+03	0.865E+04
2	2	3	0.219E+03	0.124E+03	0.113E+05	-0.219E+03	-0.124E+03	0.972E+04
3	3	4	0.200E+03	0.858E+02	0.811E+04	-0.200E+03	-0.858E+02	0.653E+04
4	4	5	0.128E+03	0.483E+02	0.380E+04	-0.128E+03	-0.483E+02	0.448E+04
5	5	6	0.324E+02	0.110E+02	0.277E+03	-0.324E+02	-0.110E+02	0.133E+04
6	7	8	0.976E+03	0.157E+03	0.185E+05	-0.976E+03	-0.157E+03	0.855E+04
7	8	9	0.694E+03	0.121E+03	0.114E+05	-0.694E+03	-0.121E+03	0.972E+04
8	9	10	0.428E+03	0.844E+02	0.811E+04	-0.428E+03	-0.844E+02	0.656E+04
9	10	11	0.213E+03	0.471E+02	0.375E+04	-0.213E+03	-0.471E+02	0.441E+04
10	11	12	0.510E+02	0.115E+02	0.350E+03	-0.510E+02	-0.115E+02	0.135E+04
11	2	8	0.364E+02	-0.139E+03	-0.200E+05	-0.364E+02	0.139E+03	-0.199E+05
12	3	9	0.367E+02	-0.124E+03	-0.178E+05	-0.367E+02	0.124E+03	-0.178E+05
13	4	10	0.374E+02	-0.717E+02	-0.103E+05	-0.374E+02	0.717E+02	-0.103E+05
14	5	11	0.355E+02	-0.330E+02	-0.475E+04	-0.355E+02	0.330E+02	-0.476E+04
15	6	12	0.116E+02	-0.931E+01	-0.133E+04	-0.116E+02	0.931E+01	-0.135E+04
16	13	14	0.392E+04	0.149E-02	0.274E-15	-0.392E+04	-0.149E-02	0.251E+00
17	14	15	0.293E+04	0.319E-01	0.297E+01	-0.293E+04	-0.319E-01	0.239E+01
18	15	16	0.195E+04	0.242E-01	0.208E+01	-0.195E+04	-0.242E-01	0.199E+01
19	16	17	0.967E+03	0.306E-01	0.247E+01	-0.967E+03	-0.306E-01	0.266E+01
20	17	18	0.147E+03	0.148E-01	0.772E+00	-0.147E+03	-0.148E-01	0.136E+01
21	8	14	-0.304E-01	-0.607E-01	-0.357E+01	0.304E-01	0.607E-01	-0.323E+01
22	9	15	0.769E-02	-0.800E-01	-0.449E+01	-0.769E-02	0.800E-01	-0.447E+01
23	10	16	-0.631E-02	-0.834E-01	-0.488E+01	0.631E-02	0.834E-01	-0.447E+01
24	11	17	0.157E-01	-0.632E-01	-0.364E+01	-0.157E-01	0.632E-01	-0.343E+01
25	12	18	0.148E-01	-0.275E-01	-0.172E+01	-0.148E-01	0.275E-01	-0.136E+01

*Highlight
Key output*

Verify Preliminary Design using PLFNL2 P-Δ Output

Beam L₆ (Member 15), W14x68, Z=115 in³, A=20.0 in², I=722 in⁴, d=14.0", t_w=0.415"

Axial Force – 11.6^k © $\sigma = P/A = 11.6/20 = 0.58$ ksi negligible

Shear – 9.31^k; Check shear: LRFD (d * t_w * ksi) > V_{max}

$$14'' * 0.415'' * 50 \text{ ksi} = 290.5^k > 9.31^k$$

Shear O.K.

Max Moment – 1350^{in-k} = 112.5^{ft-k}

$$\Phi_c ZF_y = .9 * 115 \text{ in}^3 * 50 \text{ ksi} = 5175^{\text{in-k}} > 1350^{\text{in-k}}$$

Moment O.K.

Beam L₅ (Member 14), W21x83, Z=196 in³, A=24.3 in², I=1830 in⁴, d=21.4", t_w=0.515"

Axial Force – 35.5^k © $\sigma = P/A = 35.5/24.3 = 1.46$ ksi negligible

Shear – 33^k; Check shear: LRFD (d * t_w * ksi) > V_{max}

$$21.4'' * 0.515'' * 50 \text{ ksi} = 551.0^k > 33^k$$

Shear O.K.

Max Moment – 4760^{in-k} = 396.7^{ft-k}

$$\Phi_c ZF_y = .9 * 196 \text{ in}^3 * 50 \text{ ksi} = 8820^{\text{in-k}} > 4760^{\text{in-k}}$$

Moment O.K.

Beam L₄ (Member 13), W21x132, Z=333 in³, A=38.8 in², I=3220 in⁴, d=21.8", t_w=0.650"

Axial Force – 37.4^k © $\sigma = P/A = 37.4/38.8 = 0.96$ ksi negligible

Shear – 71.7^k; Check shear: LRFD (d * t_w * ksi) > V_{max}

$$21.8'' * 0.650'' * 50 \text{ ksi} = 708.6^k > 71.7^k$$

Shear O.K.

Max Moment – 10,300^{in-k} = 858.3^{ft-k}

$$\Phi_c ZF_y = .9 * 333 \text{ in}^3 * 50 \text{ ksi} = 14,985^{\text{in-k}} > 10,300^{\text{in-k}}$$

Moment O.K.

Beam L₃ (Member 12), W30x148, Z=500 in³, A=43.5 in², I=6680 in⁴, d=30.7", t_w=0.650"

Axial Force – 36.7^k © $\sigma = P/A = 36.7/43.5 = 0.84$ ksi negligible

Shear – 124.0^k; Check shear: LRFD (d * t_w * ksi) > V_{max}

$$30.7'' * 0.650'' * 50 \text{ ksi} = 997.7^k > 124^k$$

Shear O.K.

Max Moment – 17,800^{in-k} = 1,483.3^{ft-k}

$$\Phi_c ZF_y = .9 * 500 \text{ in}^3 * 50 \text{ ksi} = 22,500^{\text{in-k}} > 17,800^{\text{in-k}}$$

Moment O.K.

Beam L₂ (Member 11), W30x191, Z=675 in³, A=56.3 in², I=9200 in⁴, d=30.7", t_w=0.710"

Axial Force – 36.4^k © $\sigma = P/A = 36.4/56.3 = 0.65$ ksi negligible

Shear – 139.0^k; Check shear: LRFD (d * t_w * ksi) > V_{max}

$$30.7'' * 0.710'' * 50 \text{ ksi} = 1089.8^k > 139^k$$

Shear O.K.

Max Moment – 20,000^{in-k} = 1,483.3^{ft-k}

$$\Phi_c ZF_y = .9 * 675 \text{ in}^3 * 50 \text{ ksi} = 30,375^{\text{in-k}} > 20,000^{\text{in-k}}$$

Moment O.K.

NOTE: Even though these calculations are substantially larger than required they actually support the lateral deflection @ 4.77" < 5.44" max

Verify Preliminary Column Design

Column Top to Splice #1(Members 4, 5, 9, 10); W24x76, $Z = 200 \text{ in}^3$, $A = 22.4 \text{ in}^2$, $I_{\text{in-plane}} = 2100 \text{ in}^4$, $d = 23.9''$, $t_w = 0.440''$, $r_{\text{in-plane}} = 9.69''$, $r_{\text{out-plane}} = 1.92''$

$P_u = \text{Axial Force} = 213^k \text{ } \odot \quad \sigma = P/A = 213/22.4 = 9.51 \text{ ksi}$

$\text{Shear} = 48.3^k$; Check shear: LRFD ($d * t_w * \text{ksi}$) > V_{max}

$22.4'' * 0.440'' * 50 \text{ ksi} = 492.8^k > 48.3^k$

Shear O.K.

$M_u = \text{Max Moment} = 4,480^{\text{in-k}} = 373.3^{\text{ft-k}}$

$\Phi_c Z F_y = .9 * 200 \text{ in}^3 * 50 \text{ ksi} = 9,000^{\text{in-k}} > 4,480^{\text{in-k}}$

Moment O.K.

Leaning Column Factor at L_4 to L_5

$= \frac{2(P_2 + P_3) + P_6 + P_5}{2(P_2 + P_3)} = \frac{2(129^k + 41.7^k) + 146.5^k + 819.5^k}{2(129^k + 41.7^k)} = \frac{341.4^k + 966.0^k}{341.4^k} = 3.83^k$

DETERMINE K IN-PLANE FROM NOMOGRAPH

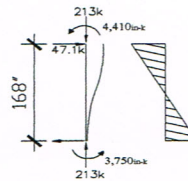
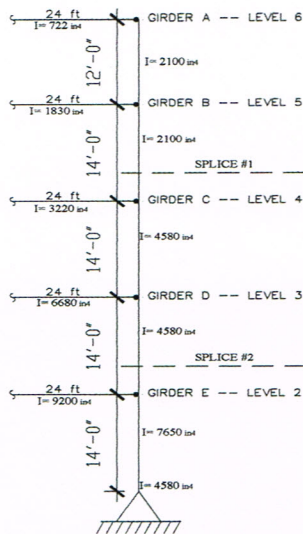

$\text{GIRDER B} = \sum \frac{EI}{L_{\text{column}}} / \sum \frac{EI}{L_{\text{beam}}} = [2100/12 + 2100/14] / [1830/24] = 2.95$

$\text{GIRDER C} = \sum \frac{EI}{L_{\text{column}}} / \sum \frac{EI}{L_{\text{beam}}} = [2100/14 + 4580/14] / [3220/24] = 3.56$

From Sidesway uninhibited nomograph, (AISC 16.1 – 242): $K = 1.9$

$K'_{\text{in-plane}} = K * \sqrt{N} = 1.9 * \sqrt{3.83} = 3.7$

$K'_{r \text{ out-of-plane}} = (1.0 * 14' * 12''/1') / 1.92'' = 87.5$ governs

$K'_{r \text{ in-plane}} = (3.7 * 14' * 12''/1') / 9.69'' = 64.1$

$F_e = (\pi^2 * 29,000) / (87.5)^2 = 37.38 \text{ ksi} > .44 * (50 \text{ ksi}) = 22 \text{ ksi}$

IN-ELASTIC

$F_{cr} = (0.658^{50/37.38}) * 50 = (0.658^{1.3376}) * 50 = 28.56 \text{ ksi}$

LRFD $\Phi_c = 0.90$

$$\Phi_c \times P_n \quad (P_n = F_{cr} \times A_g)$$

$$0.9 * 28.56 \text{ ksi} * 22.4 \text{ in}^2 = 575.9^k$$

$$P_u / \Phi P_n = 213^k \text{ } \odot / 575.9^k = 0.370 > 0.20$$

$$L_b = 14', \quad L_p = 1.76 * r_{\text{out plane}} * \sqrt{E/F_y} = 1.76 * 1.92 * \sqrt{(29,000/50)} = 81.38'' (6.78')$$

AISC 16.1-46

$$C_b = \frac{(12.5M_{max})}{(2.5M_{max} + 3M_A + 4M_B + 3M_C)} \leq 3.0$$
$$= (12.5 * 4410) / ((2.5 * 4410) + (3 * 2370) + (4 * 330) + (3 * 3750))$$
$$= 55125 / 30705 = 1.79 < 3.0$$

(From Tbl 3-2) W24x76 = $BF_{LRFD} = 22.5^k$, $\Phi M_p = 750^{\text{ft-k}}$ $L_p = 6.78'$ (81.36'')

$$\Phi M_n = C_b [\Phi M_p - BF_{LRFD} * (L_b - L_p)] < \Phi M_p$$

$$= 1.79 [750^{\text{ft-k}} - 22.5^k (14' - 6.78')] = 1.79 * (587.55^{\text{ft-k}}) = 1054.7 > 750^{\text{ft-k}}; \text{ therefore } \Phi M_n = \Phi M_p = 750^{\text{ft-k}}$$

$$P_u / \Phi P_n + (8/9) * (M_u / \Phi M_n) = 0.370 + (8/9) * (373.3^{\text{ft-k}} / 750^{\text{ft-k}}) = 0.370 + 0.4424 = 0.8124 < 1 \quad \text{O.K.}$$

Use W24x76 for top section of columns in rigid frame

Column Splice #1 to Splice #2 (Members 2, 3, 7, 8); W24x146, $Z = 418 \text{ in}^3$, $A = 43.0 \text{ in}^2$, $I = 4580 \text{ in}^4$, $d = 24.7''$,

$$t_w = 0.650'', \quad r_{\text{in plane}} = 10.3'', \quad r_{\text{out plane}} = 3.01''$$

$$P_u = \text{Axial Force} = 694^k \text{ } \odot \quad \sigma = P/A = 694/43 = 16.1 \text{ ksi}$$

$$\text{Shear} = 124^k; \text{ Check shear: LRFD } (d * t_w * \text{ksi}) > V_{\text{max}}$$

$$24.7'' * 0.650'' * 50 \text{ ksi} = 802.8^k > 124^k$$

Shear O.K.

$$M_u = \text{Max Moment} = 11,400^{\text{in-k}} = 950^{\text{ft-k}}$$

$$\Phi_c Z F_y = .9 * 418 \text{ in}^3 * 50 \text{ ksi} = 18,810^{\text{in-k}} > 4,480^{\text{in-k}} \quad \text{Moment O.K.}$$

Leaning Column Factor at L_2 to L_3

$$= \frac{2[(P_2 + P_3) + 3(P_1)] + P_6 + P_5 + 3(P_4)}{2[(P_2 + P_3) + 3(P_1)]} = \frac{2[(129^k + 41.7^k) + 3(143^k)] + 146.5^k + 819.5^k + 3(983^k)}{2[(129^k + 41.7^k) + 3(143^k)]} =$$

$$\frac{2[599.7^k] + 3915.0^k}{2[599.7^k]} = \frac{5114.4^k}{1199.4^k} = 4.26^k$$

DETERMINE K IN-PLANE FROM NOMOGRAPH

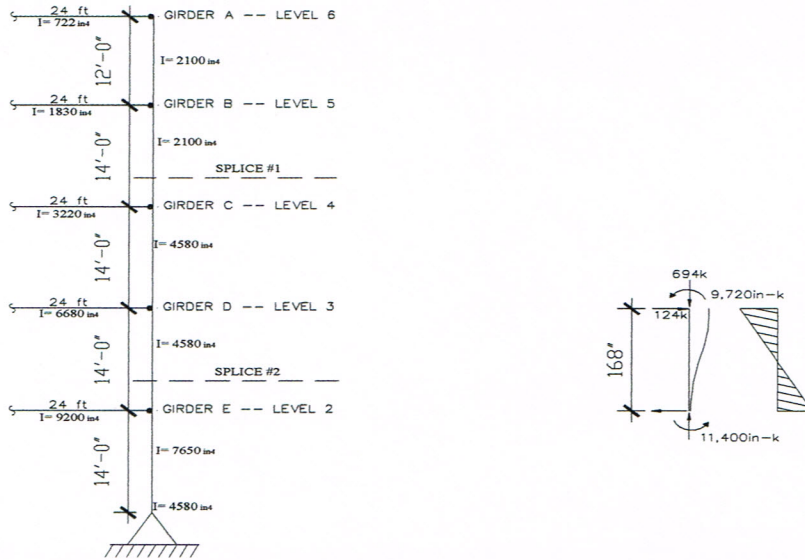

GIRDER D = $\sum E I / L_{\text{column}} / \sum E I / L_{\text{beam}} = [4580/14 + 4580/14] / [6680/24] = 2.35$
 GIRDER E = $\sum E I / L_{\text{column}} / \sum E I / L_{\text{beam}} = [4580/14 + 7650/14] / [9200/24] = 2.28$
 From Sidesway uninhibited nomograph, (AISC 16.1 - 242): $K = 1.7$
 $K'_{\text{inplane}} = K * \sqrt{N} = 1.7 * \sqrt{4.26} = 3.51$
 $KI_{\text{r out-of-plane}} = (1.0 * 14' * 12'' / 1') / 3.01'' = 55.8$
 $KI_{\text{r in-plane}} = (3.51 * 14' * 12'' / 1') / 10.3'' = 57.2$ **governs**
 $F_e = (\pi^2 * 29,000) / (57.2)^2 = 87.48 > .44 * (50 \text{ ksi}) = 22 \text{ ksi}$ **IN-ELASTIC**
 $F_{cr} = (0.658^{50/87.48}) * 50 = (0.658^{0.57156}) * 50 = 39.36 \text{ ksi}$

LRFD $\Phi_c = 0.90$

$\Phi_c * P_n$ ($P_n = F_{cr} * A_g$)

$0.9 * 39.36 \text{ ksi} * 43.0 \text{ in}^2 = 1523.3^k$

$P_u / \Phi P_n = 694^k \text{ @} / 1523.3^k = 0.4556 > 0.20$

$L_b = 14'$, $L_p = 1.76 * r_{\text{out plane}} * \sqrt{E / F_y} = 1.76 * 3.01 * \sqrt{(29,000 / 50)} = 127.58'' (10.62')$

AISC 16.1-46

$$C_b = \frac{(12.5 M_{max})}{(2.5 M_{max} + 3 M_A + 4 M_B + 3 M_C)} \leq 3.0$$

= $(12.5 * 11,400) / ((2.5 * 11,400) + (3 * 4440) + (4 * 840) + (3 * 6120))$
 = $142,500 / 63,540 = 2.24 < 3.0$

(From Tbl 3-2) W24x146 = $BF_{LRFD} = 25.8^k$, $\Phi M_p = 1570^{\text{ft-k}}$ $L_p = 10.6' (127.2'')$

$\Phi M_n = C_b [\Phi M_p - BF_{LRFD} * (L_b - L_p)] < \Phi M_p$

= $C_b [1570^{\text{ft-k}} - 25.8^k (14' - 10.6')] = 2.24 * (1482.28^{\text{ft-k}}) = 3324 > 1570^{\text{ft-k}}$; therefore $\Phi M_n = \Phi M_p = 1570^{\text{ft-k}}$

$P_u / \Phi P_n + (8/9) * (M_u / \Phi M_n) = 0.494 + (8/9) * (950^{\text{ft-k}} / 1570^{\text{ft-k}}) = 0.4556 + 0.5379 = 0.9935 < 1$ O.K.

Use W24x146 for middle section of columns in rigid frame

Column Splice #2 to Base (Members 1, 6); W24x229, $Z = 675 \text{ in}^3$, $A = 67.2 \text{ in}^2$, $I = 7650 \text{ in}^4$, $d = 26.0''$, $t_w = 0.960''$,
 $r_{\text{in plane}} = 10.7''$, $r_{\text{out plane}} = 3.11''$

$$P_u = \text{Axial Force} = 976^k \quad \sigma = P/A = 976/67.2 = 14.5 \text{ ksi}$$

$$\text{Shear} = 162^k ; \text{Check shear: LRFD } (d * t_w * \text{ksi}) > V_{\max}$$

$$26.0'' * 0.960'' * 50 \text{ ksi} = 1248^k > 162^k$$

Shear O.K.

$$M_u = \text{Max Moment} = 18,800^{\text{in-k}} = 1,566.7^{\text{ft-k}}$$

$$\Phi_c Z F_y = .9 * 675 \text{ in}^3 * 50 \text{ ksi} = 30,375^{\text{in-k}} > 18,800^{\text{in-k}} \text{ Moment O.K.}$$

DETERMINE K IN-PLANE FROM NOMOGRAPH

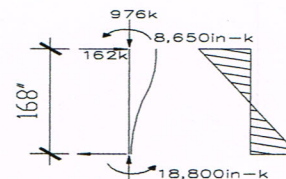
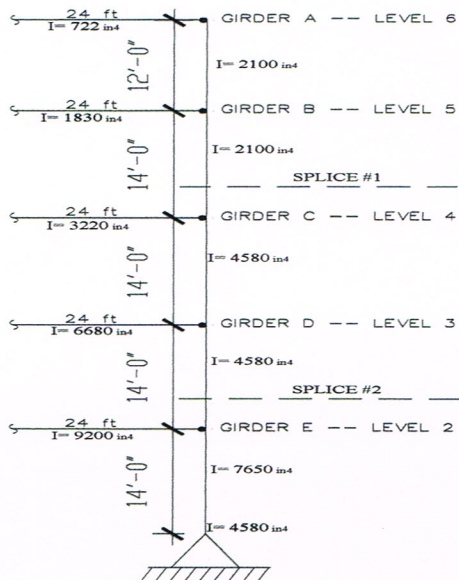

$$F_{cr} = (0.658^{50/65.51}) * 50 = (0.658^{0.7632}) * 50 = 36.33 \text{ ksi}$$

$$\text{LRFD } \Phi_c = 0.90$$

$$\Phi_c * P_n \quad (P_n = F_{cr} * A_g)$$

$$0.9 * 36.33 \text{ ksi} * 67.2 \text{ in}^2 = 2197.2^k$$

$$P_u / \Phi P_n = 976^k / 2197.2^k = 0.444 > 0.20$$

$$L_b = 14', \quad L_p = 1.76 * r_{\text{out plane}} * \sqrt{E/F_y} = 1.76 * 3.11 * \sqrt{(29,000/50)} = 131.8'' (10.98')$$

AISC 16.1-46

$$C_b = \frac{(12.5 M_{\max})}{(2.5 M_{\max} + 3 M_A + 4 M_B + 3 M_C)} \leq 3.0$$

$$= (12.5 * 18,800) / ((2.5 * 18,800) + (3 * 1787) + (4 * 5075) + (3 * 11937))$$

$$= 235,000 / 108,472 = 2.17 < 3.0$$

$$\text{(From Tbl 3-2) } W24 \times 229 = B F_{\text{LRFD}} = 28.9^k, \Phi M_p = 2530^{\text{ft-k}}, L_p = 11.0'$$

$$\Phi M_n = C_b [\Phi M_p - B F_{\text{LRFD}} * (L_b - L_p)] < \Phi M_p$$

$$= 2.17 [2530^{\text{ft-k}} - 28.9^k (14' - 11')] = 2.17 * (2443.3^{\text{ft-k}}) = 5293 > 2530^{\text{ft-k}} ; \text{therefore } \Phi M_n = \Phi M_p = 2530^{\text{ft-k}}$$

$$P_u / \Phi P_n + (8/9) * (M_u / \Phi M_n) = 0.444 + (8/9) * (1567^{\text{ft-k}} / 2530^{\text{ft-k}}) = 0.444 + 0.551 = 0.9945 < 1 \quad \text{O.K.}$$

Use W24x229 for bottom section of columns in rigid frame