

# LIFE-SAFETY INFORMATION

<b>APPLICABLE CODES</b>			
NFPA 101 LIFE-SAFETY CODE 2015 AND IBC 2021			
OCCUPANCY TYPE(S) AND CHAPTER(S)			
ASSEMBLY A-3 (CHAPTER 3)			
<b>OCCUPANT LOAD FACTOR</b>		(REFERENCE TABLE 7.3.1.2)	
BLDG 'A' - ASSEMBLY A-3	50 GROSS - Exercise rooms	1st Flr = 15,526 s.f. / 50 gross = 310	2nd Flr = 14,150 s.f. / 50 gross = 283
BLDG 'B' - ASSEMBLY A-3	50 GROSS - Exercise rooms	1st Flr = 4,894 s.f. / 50 gross = 98	2nd Flr = 2,651 s.f. / 50 gross = 53
BLDG 'C' - ASSEMBLY A-3	50 GROSS - Exercise rooms	1st Flr = 21,605 s.f. / 50 gross = 432	2nd Flr = 12,784 s.f. / 50 gross = 256
<b>CLASSIFICATION OF HAZARD OF CONTENTS</b>			
(REFERENCE: OCCUPANCY CHAPTER AND 6.2.2: SPECIFY LOW, ORDINARY, OR HIGH)			
CONSTRUCTION TYPE: VB (REFERENCE: CHAPTERS, TABLE A.8.2.1.2 AND COMMENTARY TABLE 6.1 IN HANDBOOK)			
MINIMUM EXIT SEPARATION DISTANCE FOR REMOTELY LOCATED EXITS			
(REFERENCE: SECTION 7.5; SPECIFY 1/2 OR 1/3 DIAGONAL DISTANCE OF AREA SERVED)			
1/2 DIAGONAL = 47'-0"			
<b>MAXIMUM DEAD-END CORRIDORS</b> (REFERENCE: OCCUPANCY CHAPTER AND TABLE A.7.6)			
20 FEET			
<b>MAXIMUM COMMON PATH OF TRAVEL DISTANCE</b> (REFERENCE: OCCUPANCY CHAPTER AND TABLE A.7.6)			
20 FEET/75 FEET			
<b>MAXIMUM TRAVEL DISTANCE TO EXITS</b> (REFERENCE: OCCUPANCY CHAPTER AND TABLE A.7.6)			
200 FEET			
MAIN ENTRANCES MUST BE SIGNED TO ACCOMMODATE 1/2 OCCUPANT LOAD OF BUILDING			
<b>EXTINGUISHMENT REQUIREMENTS</b>		SPRINKLERED	
<b>DETECTION, ALARM, AND COMMUNICATION SYSTEMS</b>		YES	
<b>ALLOWABLE HEIGHT AND BUILDING AREA</b>		PER IBC EQUIVALENT CONSTRUCTION TYPE	

# CROSS GATES ATHLETIC CLUB SLIDELL LOUISIANA

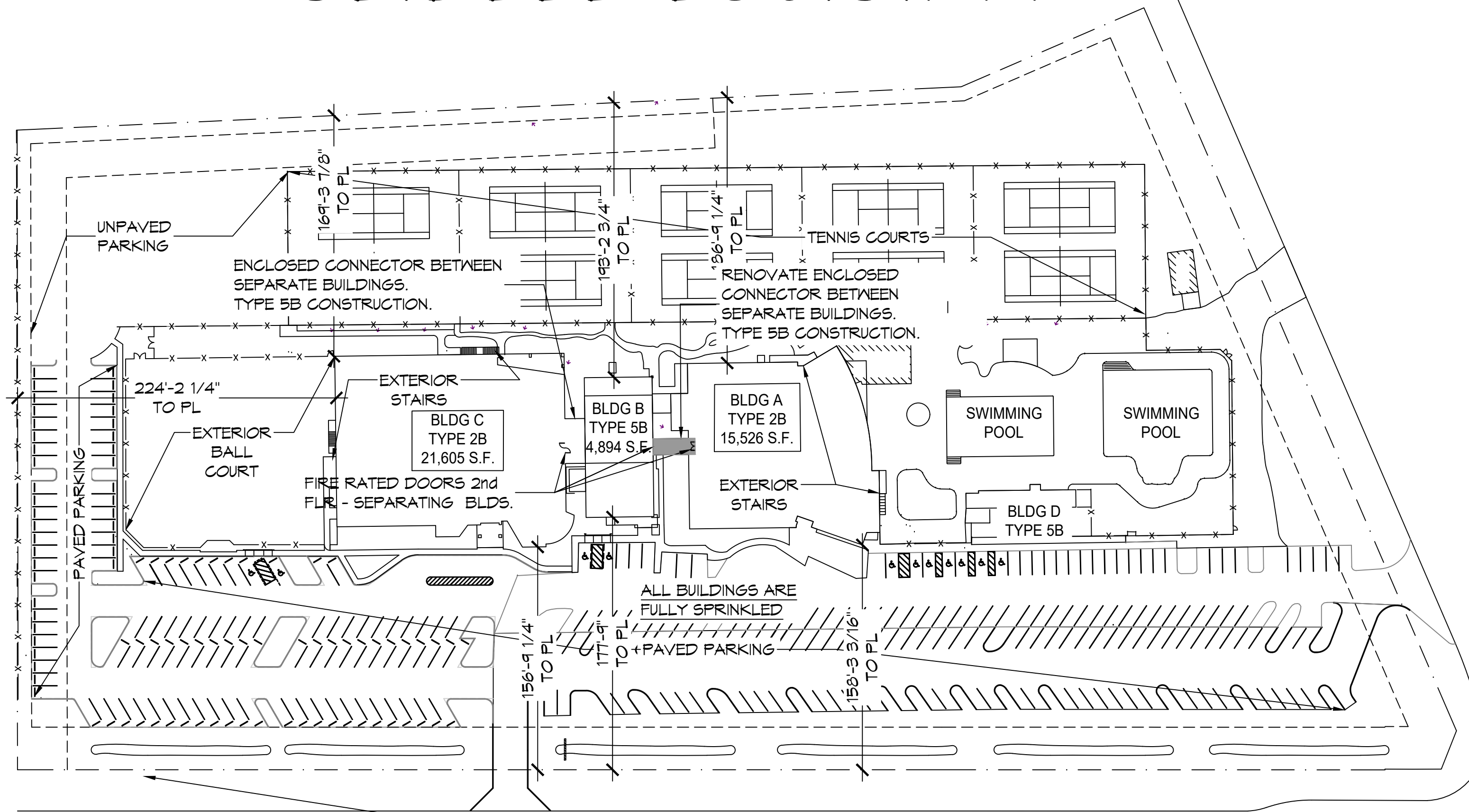

MILITARY ROAD  
60 FT RIGHT OF WAY

## SITE PLAN

SCALE: 1"=64' = 1"=0'

# BUILDING CODE INFORMATION

<b>APPLICABLE CODES</b>			
IBC 2021			
<b>ASSEMBLY GROUP AS</b>		(IBC 2015 CHAPTER 3)	
<b>OCCUPANT LOAD CALCULATIONS</b> (REFERENCE TABLE 1004.1.2)			
BLDG 'A' - ASSEMBLY A-3	50 GROSS - Exercise rooms	1st Flr = 15,526 s.f. / 50 gross = 310	2nd Flr = 14,150 s.f. / 50 gross = 283
BLDG 'B' - ASSEMBLY A-3	50 GROSS - Exercise rooms	1st Flr = 4,894 s.f. / 50 gross = 98	2nd Flr = 2,651 s.f. / 50 gross = 53
BLDG 'C' - ASSEMBLY A-3	50 GROSS - Exercise rooms	1st Flr = 21,605 s.f. / 50 gross = 432	2nd Flr = 12,784 s.f. / 50 gross = 256
<b>TOTAL OCCUPANTS</b>		BLDG A = 598; Bldg B = 152; Bldg C = 688	
<b>CONSTRUCTION TYPE(S)</b>		(TABLE 503)	
IB 4 VB			
<b>ALLOWABLE HEIGHT AND BUILDING AREA LIMITED BY TYPE OF CONSTRUCTION</b>			
MAXIMUM HEIGHT (IBC TABLE 504.3)	MAXIMUM STORES (IBC TABLE 504.4)	ALLOWABLE AREA FACTOR MULTI STORY SPRINKLED	ALLOWABLE AREA FACTOR MULTI STORY NON-SPRINKLED
BLDG A, SPRINKLED, TYP 2B = 75 FT	BLDG A, SPRINKLED, TYP 2B = 3	SM = 28,500 s.f.	NS = 9,500 s.f.
BLDG B, SPRINKLED, TYP 5B = 60 FT	BLDG B, SPRINKLED, TYP 5B = 2	SM = 18,000 s.f.	NS = 6,000 s.f.
BLDG C, SPRINKLED, TYP 2B = 75 FT	BLDG C, SPRINKLED, TYP 2B = 3	SM = 28,500 s.f.	NS = 9,500 s.f.

# WIND SPEED DESIGN REQUIREMENTS

THIS BUILDING SHALL BE DESIGNED WITH IBC SEC 1609 AS A FULLY ENCLOSED BLDG USING THE FOLLOWING INFORMATION:

WIND DESIGN DATA: DETERMINATION OF WIND LOADS SHALL BE IN ACCORDANCE WITH IBC SEC 1609.3 (A), (B), OR (C) DEPENDING ON THE RISK CATEGORY			
ULTIMATE WIND SPEED = 141 MPH (IBC FIG 1609C)	NOMINAL WIND SPEED = V <sub>98d</sub> = 104 MPH		
RISK FACTOR: CATEGORY II	SURFACE ROUGHNESS = B		
TOPOGRAPHIC FACTOR = 1	EXPOSURE = B		
INTERNAL PRESSURE COEFFICIENT (ASCE 7-10 TABLE 26.11-1): ± 0.18			
<b>LIVE LOADS (IBC SEC 1607)</b>			
ASSEMBLY FIXED SEATING (IBC TABLE 1607.1):	60 PSF		
PLATFORMS (ASSEMBLY) (IBC TABLE 1607.1):	100 PSF		
LOBBIES (IBC TABLE 1607.1):	100 PSF		
CLASSROOMS (IBC TABLE 1607.1):	40 PSF UNIFORM, 1,000 LB CONCENTRATED		
ROOF LIVE LOADS (IBC TABLE 1607.1):	20 PSF UNIFORM, 300 LB CONCENTRATED		
<b>SNOW LOADS (IBC TABLE 1608)</b>			
GROUND SNOW LOAD (IBC FIG 1608.2):	5 PSF		

# FLOOD ZONE INFORMATION

BASED ON THE SURVEY OF THIS PROPERTY BY J.V. BURKES AND ASSOCIATES, INC. THIS PROPERTY IS IN A SPECIAL FLOOD HAZARD AREA. F.I.R.M. COMMUNITY MAP NO 220205 0420 E; REVISED 4/21/99

FLOOD ZONE:	A	BASE FLOOD ELEVATION:	17.0 NGVD
ELEVATIONS REFER TO NGVD 1929 DATUM			

# PROJECT STATISTICS

EXISTING BUILDINGS	YEAR BUILT	CONSTRUCTION TYPE	1st FLOOR GROSS S.F.	2nd FLOOR GROSS S.F.
BLDG A	1997	II B	21,605	10,203
BLDG B		VB	4,894	2,536
BLDG C	2006	II B	15,526	14,161

**Project Synopsis:**

Cross Gates Athletic Club has three (3) existing main buildings A, B, & C. Building B is the original building; the newer buildings, A & C, were constructed at a higher elevations due to FEMA Flood maps at the time of their construction. Currently the buildings are connected on the first floor via enclosed connectors with stairs that serve the staff & customers to move from building to building without requiring them to exit one building to enter the next. The second floor of Building B is connected to the second floor of building C with stairs; however there is no path from the 2nd floor of building A to the second floor of building B.

The owner wants to create an open floor such that a person could walk from the 2nd floor of building A thru the 2nd floor of B to the second floor of building C.

Building B is metal building with wood frame construction for interior walls and 2nd floor support. The connector between buildings A & B is constructed of wood frame construction. This project extends building B to the face of buildings A & C.

Each of the buildings at the connection between buildings, will be separated with 1 1/2 hour fire rated doors that area magnetically held open and connected to the fire alarm system. All 3 buildings, as well as connectors, are sprinkled and none of the existing Egress routes will be altered during this construction.

**PROJECT LOCATION:**  
300 NORTH MILITARY ROAD  
SLIDELL, LA 70460

**OWNER:**  
CROSS GATES ATHLETIC CLUB  
LARRY WELCH

ALLOWABLE BLDG AREA INCREASE BLDG A	ALLOWABLE BLDG AREA INCREASE BLDG B	ALLOWABLE BLDG AREA INCREASE BLDG C
BLDG FULLY SPRINKLED, BLDG CONSTRUCTION 2B ASSEMBLY GROUP A-3, SM = 28,500 s.f.; NS = 9,500 s.f. W = 30 (SHALL NOT EXCEED 30, IBC SEC. 506.3.2) IF = (F/P - 0.25) X W/30 (IBC SEC. 506.3.3) F = 249.66ft; P = 549.58ft; IF = ((249.66/549.58) - 0.25) X (30/30) IF = 0.20	BLDG FULLY SPRINKLED, BLDG CONSTRUCTION 5B ASSEMBLY GROUP A-3, SM = 18,000 s.f.; NS = 6,000 s.f. W = 30 (SHALL NOT EXCEED 30, IBC SEC. 506.3.2) IF = (F/P - 0.25) X W/30 (IBC SEC. 506.3.3) F = 95.33 ft; P = 292.0 ft IF = ((95.33/292.0) - 0.25) X (30/30) IF = 0.076	BLDG FULLY SPRINKLED, BLDG CONSTRUCTION 2B ASSEMBLY GROUP A-3, SM = 28,500 s.f.; NS = 9,500 s.f. W = 30 (SHALL NOT EXCEED 30, IBC SEC. 506.3.2) IF = (F/P - 0.25) X W/30 (IBC SEC. 506.3.3) F = 494.66 ft; P = 599.75 ft; IF = ((494.66/599.75) - 0.25) X (30/30) IF = 0.575
$Aa = [At + (NS \times IF)] \times Sa$ $Aa = [28,500 + (9,500 \times 0.2)] \times 2$ $Aa = 60,800 \text{ s.f.} / 2 \text{ STORIES} = 30,400 \text{ s.f. Each Floor}$	$Aa = [At + (At \times IF) + (At \times Is)] \times Sa$ $Aa = [18,000 + (6,000 \times 0.076)] \times 2$ $Aa = 36,912 \text{ s.f.} / 2 \text{ STORIES} = 18,456 \text{ s.f. Each Floor}$	$Aa = [At + (NS \times IF)] \times Sa$ $Aa = [28,500 + (9,500 \times 0.575)] \times 2$ $Aa = 67,925 \text{ s.f.} / 2 \text{ STORIES} = 33,962 \text{ s.f. Each Floor}$

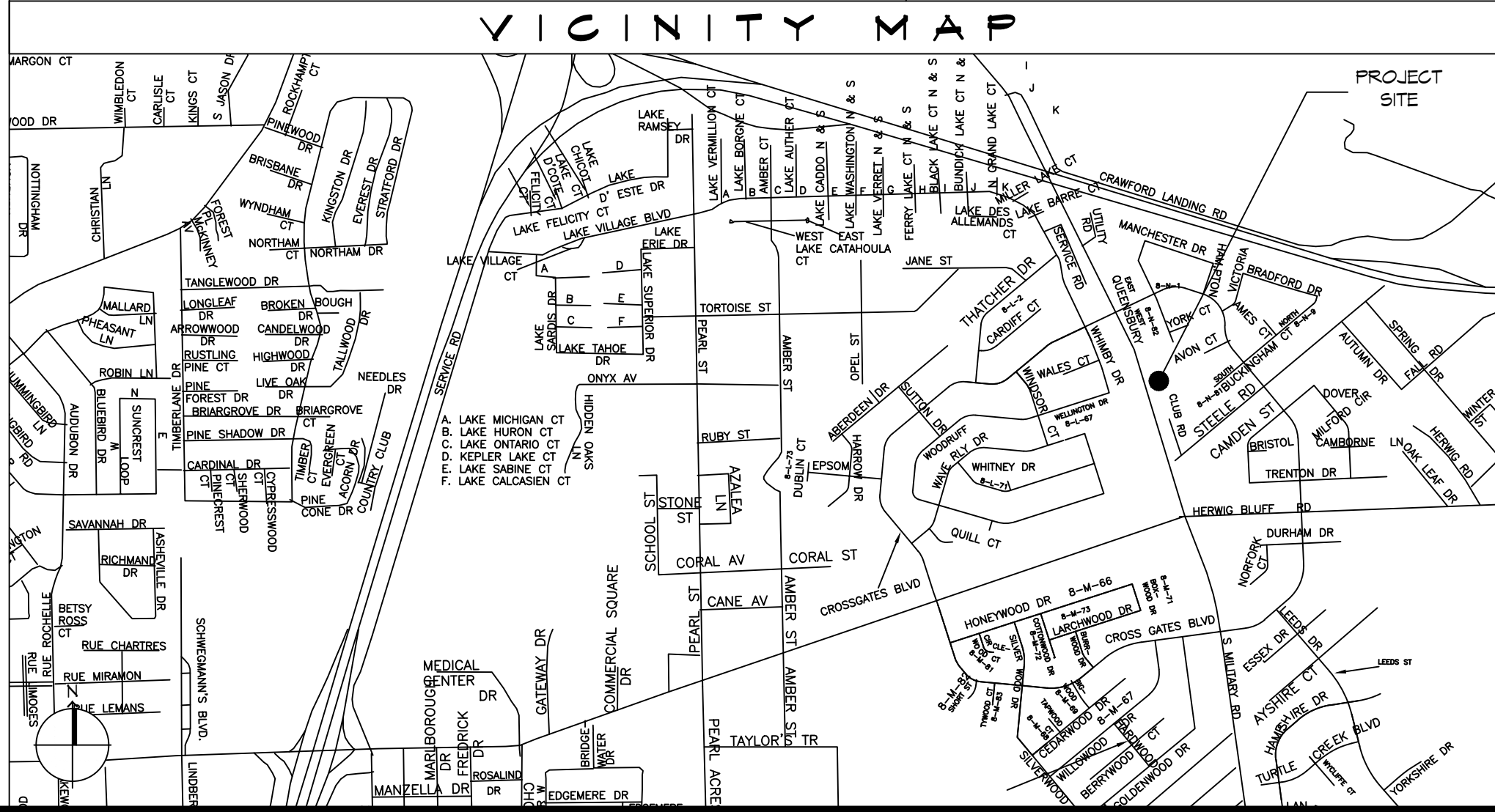

## SHEET INDEX

SHEET #	SHEET TITLE
0001	GENERAL PROJECT, LIFE-SAFETY, AND BUILDING CODE INFORMATION
G101	OVERALL SITE PLAN
D101	1ST & 2ND FLOOR BLDG A & B - DEMO PLAN
A101	1st & 2nd FLOOR PLANS
A102	BLDG A - B CONNECTOR SECTIONS AND ROOF PLAN
A103	PARTIAL ELEVATION
A104	TYPICAL CONNECTION DETAILS-SCHEDULES & NOTES
E101	LIGHTING AND POWER PLAN

## GENERAL NOTES

- ALL MATERIALS AND WORK, INCIDENTAL TO THE CONSTRUCTION OF THIS PROJECT, SHALL CONFORM TO ALL GOVERNING CODES, AND REGULATIONS OF AGENCIES IN AUTHORITY.
- CONTRACTOR SHALL PROVIDE ALL PUBLIC PROTECTIONS NECESSARY AS REQUIRED BY LAW.
- THE DRAWINGS, SPECIFICATIONS AND ANY SUBSEQUENTLY ISSUED ADDENDA, AMENDMENTS OR SUCH CHANGE ORDERS APPROVED BY THE OWNER AND THE CONTRACTOR ARE PART OF THESE CONTRACT DOCUMENTS.
- DO NOT SCALE DRAWINGS. CONSULT WITH THE ARCHITECT REGARDING ANY ITEMS IN THE CONTRACT DOCUMENTS THAT REQUIRE CLARIFICATION.
- TRASH SHALL BE REMOVED FROM THE SITE NOT LESS THAN TWICE MONTHLY.
- THE GENERAL CONTRACTOR SHALL VERIFY EXISTING CONDITIONS PRIOR TO COMMENCING WORK AND REPORT ANY AND ALL DISCREPANCIES TO THE ARCHITECT.
- CONTRACTOR VEHICLES AND EQUIPMENT NECESSARY FOR CONSTRUCTION MAY BE PARKED ON THE SITE. OTHER VEHICLES PARKED ON THE SITE REQUIRE THE OWNER'S PERMISSION.
- NAMING A CERTAIN BRAND, MAKE OR MANUFACTURER IS TO DESIGNATE THE GENERAL STYLE, TYPE, CHARACTER AND QUALITY STANDARD OF THE PRODUCT DESIRED. SUBSTITUTION REQUESTS MUST BE SUBMITTED PRIOR TO BIDDING.
- ALL MATERIALS/EQUIPMENT SHALL BE INSTALLED PER MANUFACTURER'S RECOMMENDATIONS. WORK NOT CONSISTENT WITH MANUFACTURER'S RECOMMENDATIONS WILL BE REJECTED BY OWNER/ARCHITECT.

**DAMMON ENGINEERING, INC.**  
LOUISIANA & MISSISSIPPI

www.dammonengineering.com  
554 Old Spanish Trail  
Slidell, LA 70458  
PH: 985.646.5832

Chief Engineer: Brian Mistich, PE  
info@dammonengineering.com

DATE	REVISIONS	DESCRIPTION

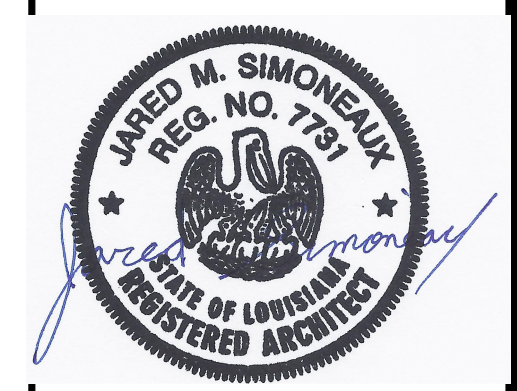

**CROSS GATES ATHLETIC CLUB**

200 NORTH MILITARY ROAD  
SLIDELL, LA

JOB NO.: 2321 DATE: 09-09-24  
DRAWN BY: JTL CHECKED BY: JMS

**GOO1**

SHEET TITLE: GENERAL PROJECT, LIFE-SAFETY, AND BUILDING CODE INFORMATION

DRAWING NUMBER:

SHEET NO: 1 of 6



**GENERAL DEMO NOTES**

1. THIS DEMOLITION PLAN HAS BEEN DERIVED FROM EXISTING BUILDING PLANS AND ARE INTENDED TO REASONABLY REPRESENT EXISTING CONDITIONS. ENGINEER DOES NOT GUARANTEE ACCURACY OF THE EXISTING CONDITIONS. CONTRACTOR TO FIELD VERIFY EXISTING CONDITIONS IN AREAS TO BE RENOVATED PRIOR TO BID IN ORDER TO PROVIDE AN ACCURATE BID AND BE AWARE OF ALL CONSTRUCTION METHODS NEEDED TO PROVIDE THE FINISHED PRODUCT AS SHOWN ON THE PLANS. ILLUSTRATIONS, DIMENSIONS, AND INFORMATION IN THESE DRAWINGS ARE BASED, IN PART, ON EXISTING DRAWINGS FURNISHED BY THE OWNER. ACTUAL CONDITIONS MAY DEVIATE FROM THAT SHOWN ON THE DRAWINGS. THE CONTRACTOR SHALL VERIFY ACTUAL CONDITIONS AND COORDINATE THE DEMOLITION WITH NEW WORK SO THAT DEMOLITION IS COMPLETE.
2. THE CONTRACTOR SHALL COORDINATE REMOVAL OF SMOKE AND OTHER FIRE ALARM ADDRESSABLE UNITS ATTACHED TO THE AHU WITH THE FIRE ALARM CONTRACTOR PRIOR TO REMOVAL.
3. THE CONTRACTOR SHALL TAKE ALL NECESSARY PRECAUTIONS TO ENSURE THE SAFETY OF THE PUBLIC AND/OR WORKMEN ON THE SITE TO PREVENT ACCIDENTS OR INJURY TO ANY PERSON ON OR ADJACENT TO THE PREMISES. THE CONTRACTOR SHALL COMPLY WITH ALL LAWS, ORDINANCES, AND REGULATIONS PERTAINING TO SAFETY AND THE PREVENTION OF ACCIDENTS.
4. ALL EXISTING STEEL FRAMING MEMBERS (COLUMNS, BEAMS, JOISTS, DECK, ETC...) SHALL REMAIN INTACT AND UNDAMAGED.
5. WHEN DEMOLITION TAKES PLACE, SHOULD ANY WORK AFFECT THE INTEGRITY OF THE STRUCTURE, WORK MUST STOP IMMEDIATELY, AND DAMMON ENGINEERING NOTIFIED. UNDER NO CIRCUMSTANCES SHALL REINFORCING OF ANY KIND BE DAMAGED, CUT, OR BROKEN.
6. EXISTING ITEMS, EQUIPMENT, PLUMBING FIXTURES, ETC. TO REMAIN IN PLACE SHALL BE PROTECTED FROM DIRT AND DAMAGE DURING DEMOLITION AND CONSTRUCTION.
7. ALL OPENINGS AND VOIDS LEFT BY THE REMOVAL OF EXISTING CONSTRUCTION, EQUIPMENT, PIPING, DUCTS, ETC. SHALL BE PROPERLY PATCHED AND CLOSED OFF TO MAINTAIN PROPER FIRE RATING IN WALL. PREPARE PATCHES TO RECEIVE NEW FINISHES AS REQUIRED.
8. WHERE A RATING HAS BEEN GIVEN TO AN EXISTING WALL, ALL PENETRATIONS (EXISTING OR NEW) MUST BE SEALED AND PROPERLY FIREPROOFED PER THAT RATING REQUIREMENT.
9. REMOVAL OF EXISTING HVAC SHALL INCLUDE DUCT WORK HANGERS, GRILLES, DIFFUSERS, THERMOSTATS, ETC. AS REQUIRED TO COMPLETE DEMOLITION.

**DAMMON ENGINEERING, INC.**  
LOUISIANA & MISSISSIPPI

www.dammonengineering.com  
info@dammoneng.com  
PH: 985.649.5832

Chief Engineer: Brian Mistich, PE  
13400 Highway 134  
Slidell, LA 70688

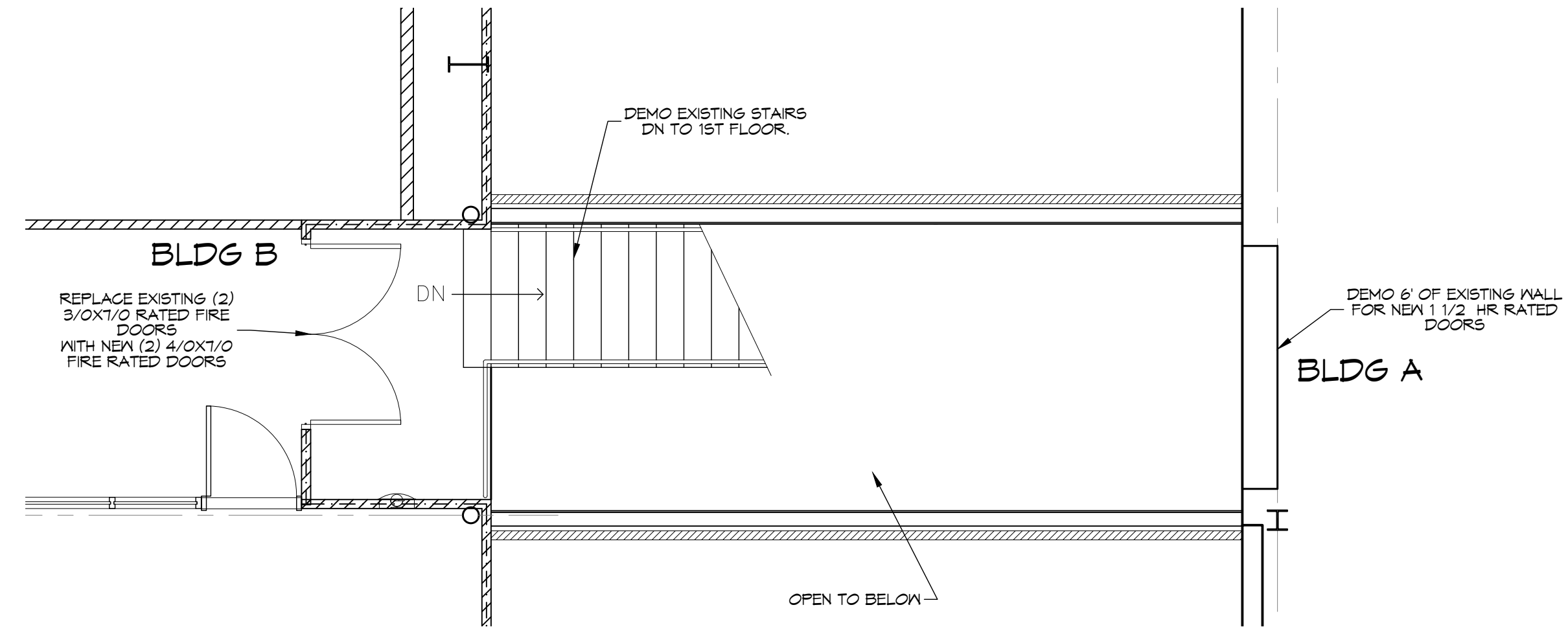

**3 2nd FLOOR BLDG A & B - DEMO PLAN**  
SCALE: 1/8"=1'-0"

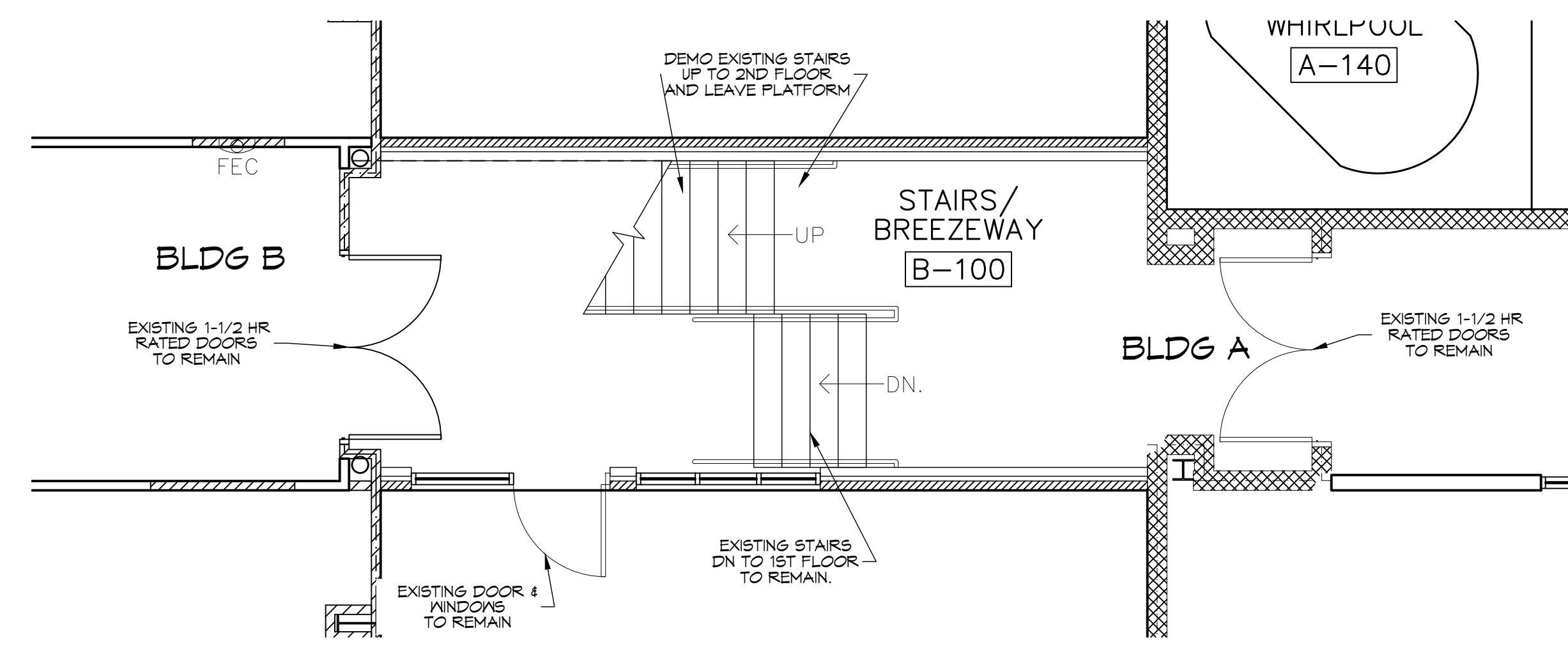

**2 1ST FLOOR BLDG A & B - DEMO PLAN**  
SCALE: 1/8"=1'-0"

#	DESCRIPTION	DATE

SEAL:

STAIR ADDITION  
**CROSSETTES CLUB**  
ATHLETIC CLUB

200 NORTH MILITARY ROAD  
SLIDELL, LA.

JOB No: 2927 DATE: 08-09-24  
DRAWN BY: JTL CHECKED BY: GAD

SHEET TITLE:  
1ST & 2nd FLOOR BLDG A & B - DEMO PLAN

DRAWING NUMBER:  
**D101**

SHEET No: 3 of 3



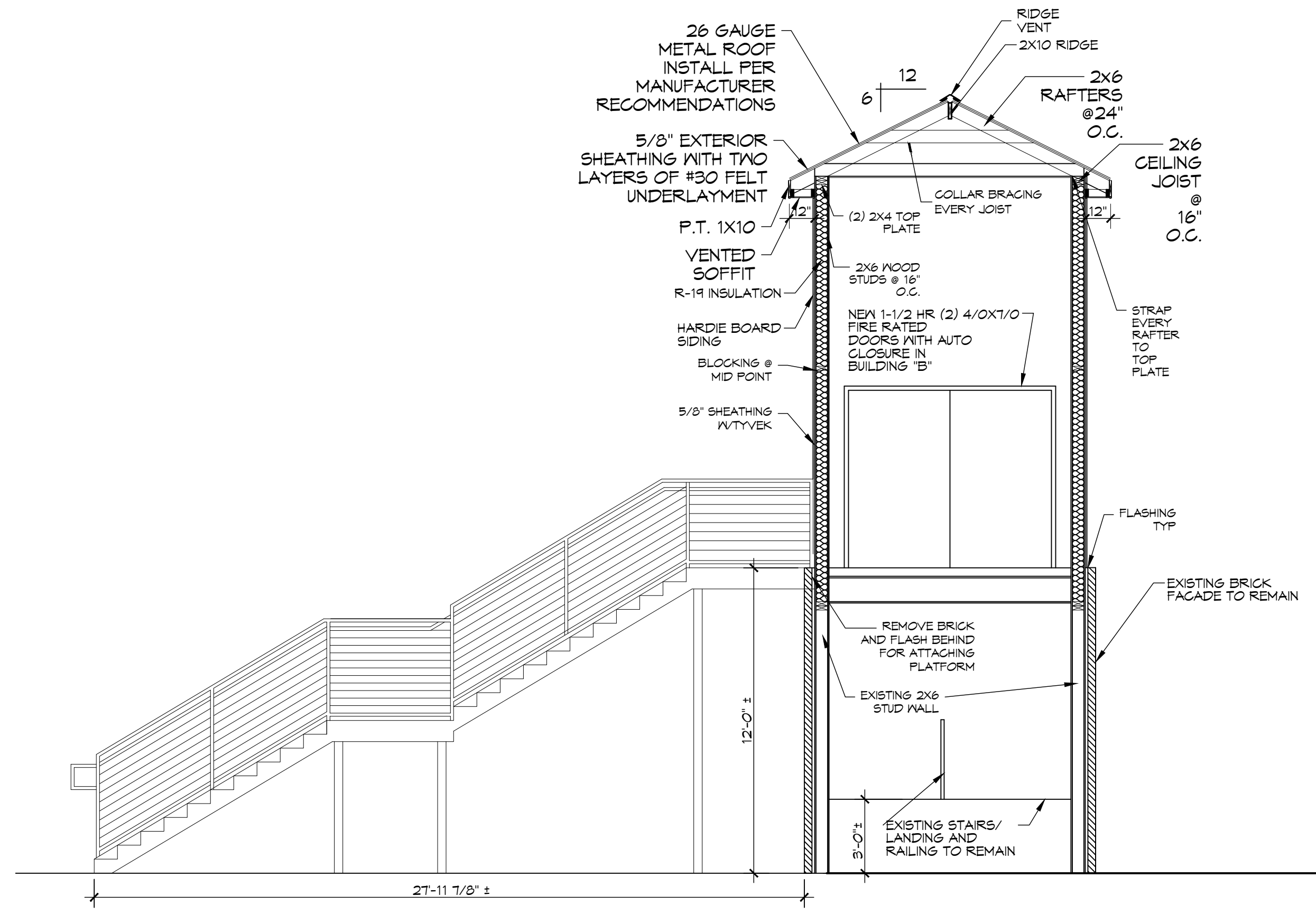

**A SECTION**  
SCALE: 1/4" = 1'-0"

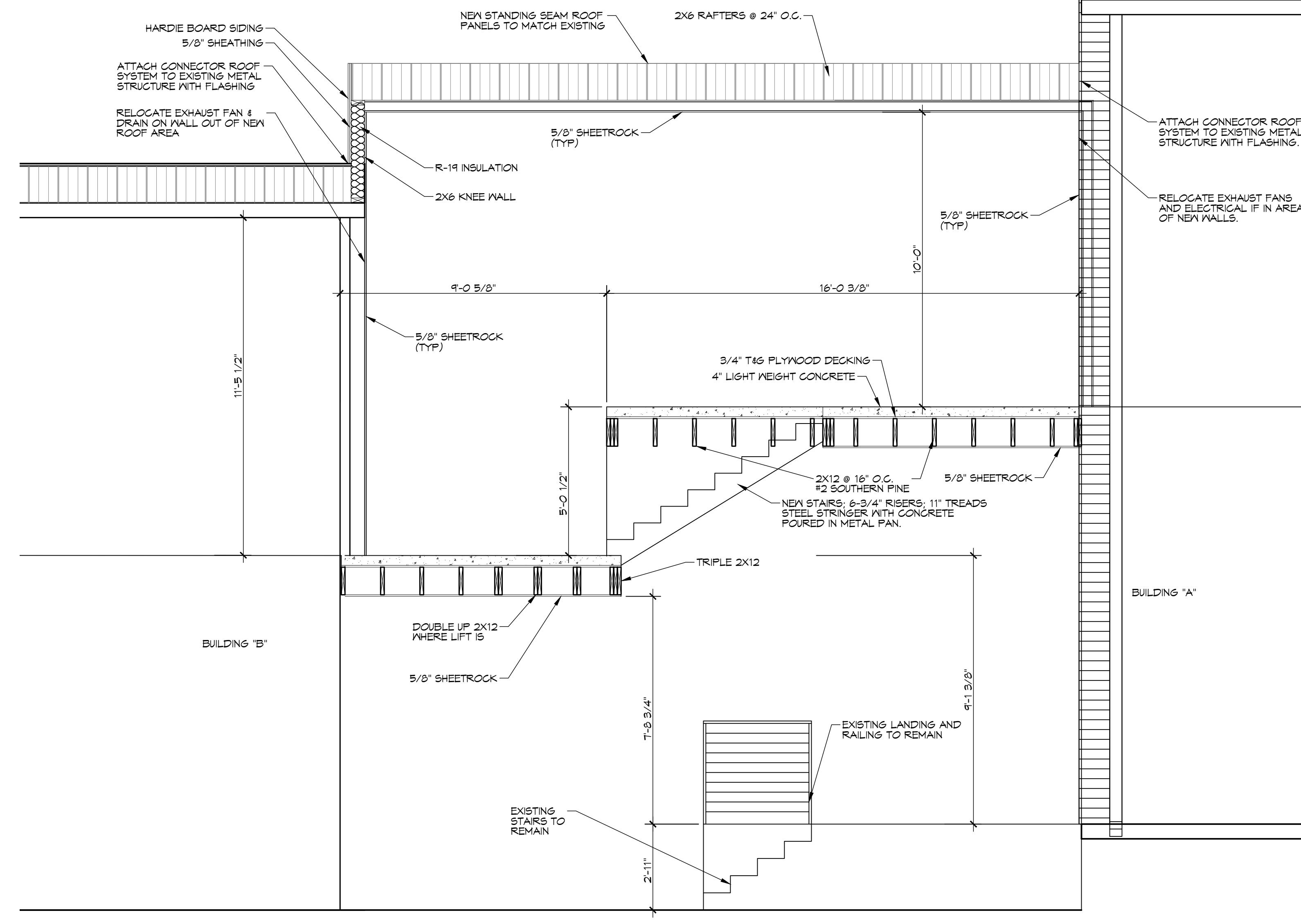

**B SECTION OF CONNECTOR BLDG A - B**  
SCALE: 3/8" = 1'-0"

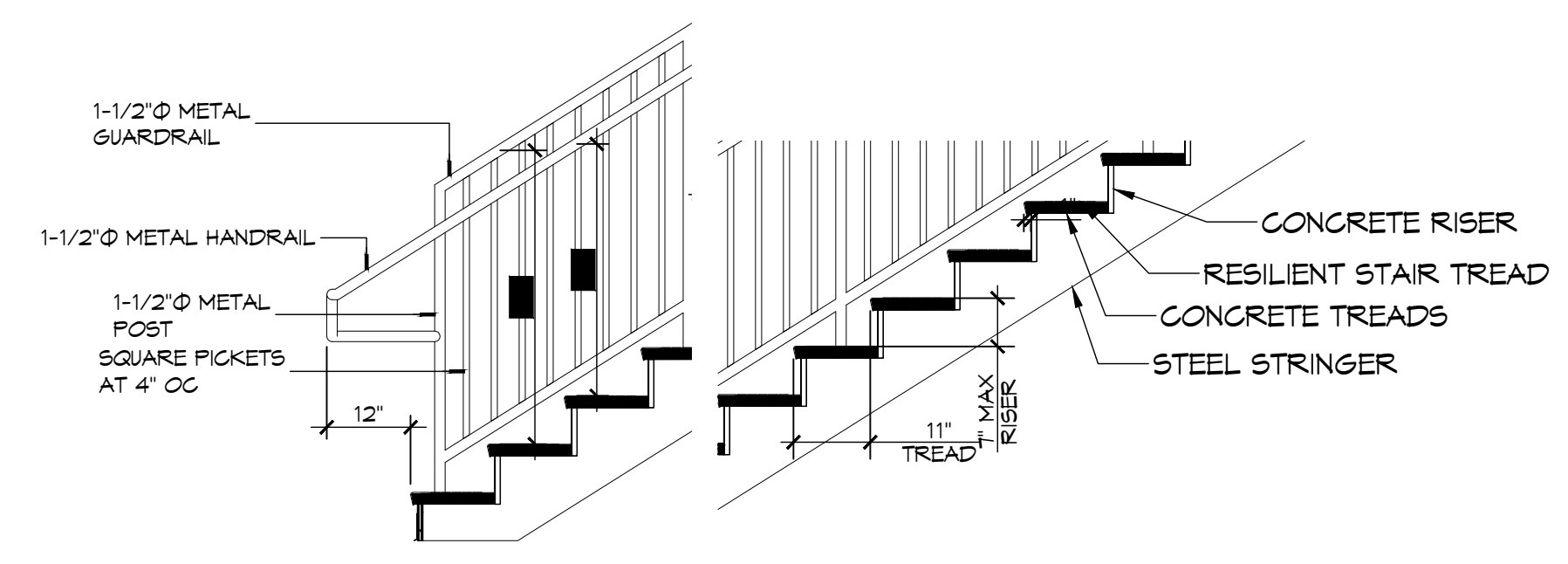

**6 DETAIL**  
SCALE: 1/2" = 1'-0" STAIR GUARDRAIL

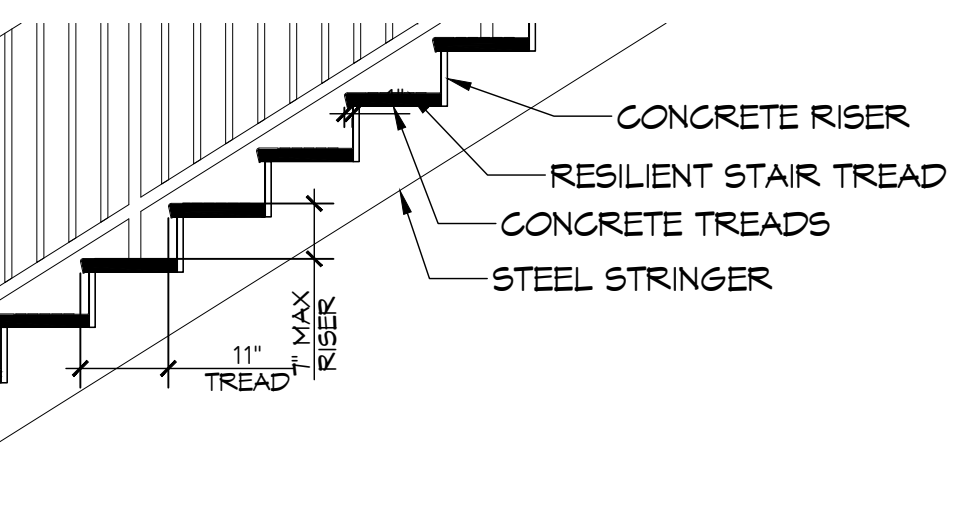

**7 DETAIL**  
SCALE: 1/2" = 1'-0" TYPICAL STAIR TREAD/RISER

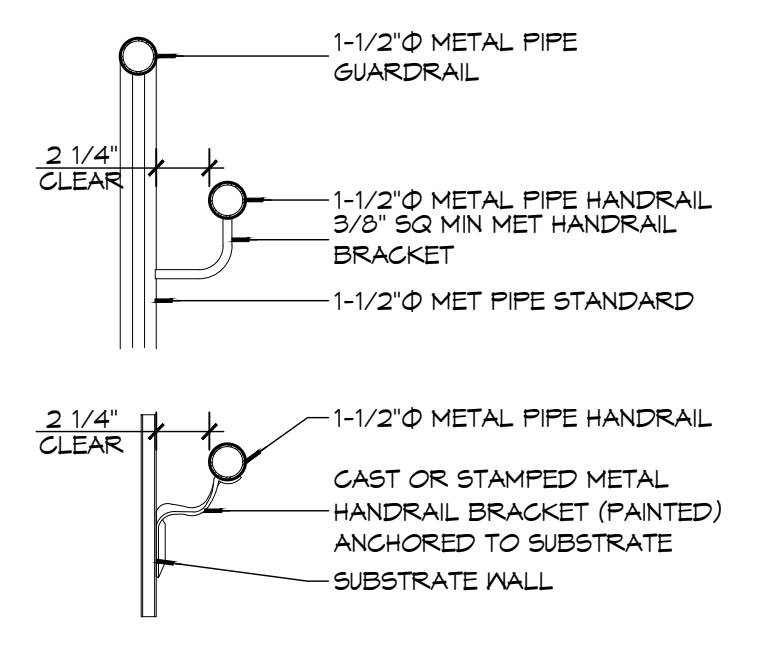

**8 DETAIL**  
SCALE: 1-1/2" = 1'-0" WALL ATTACHMENT

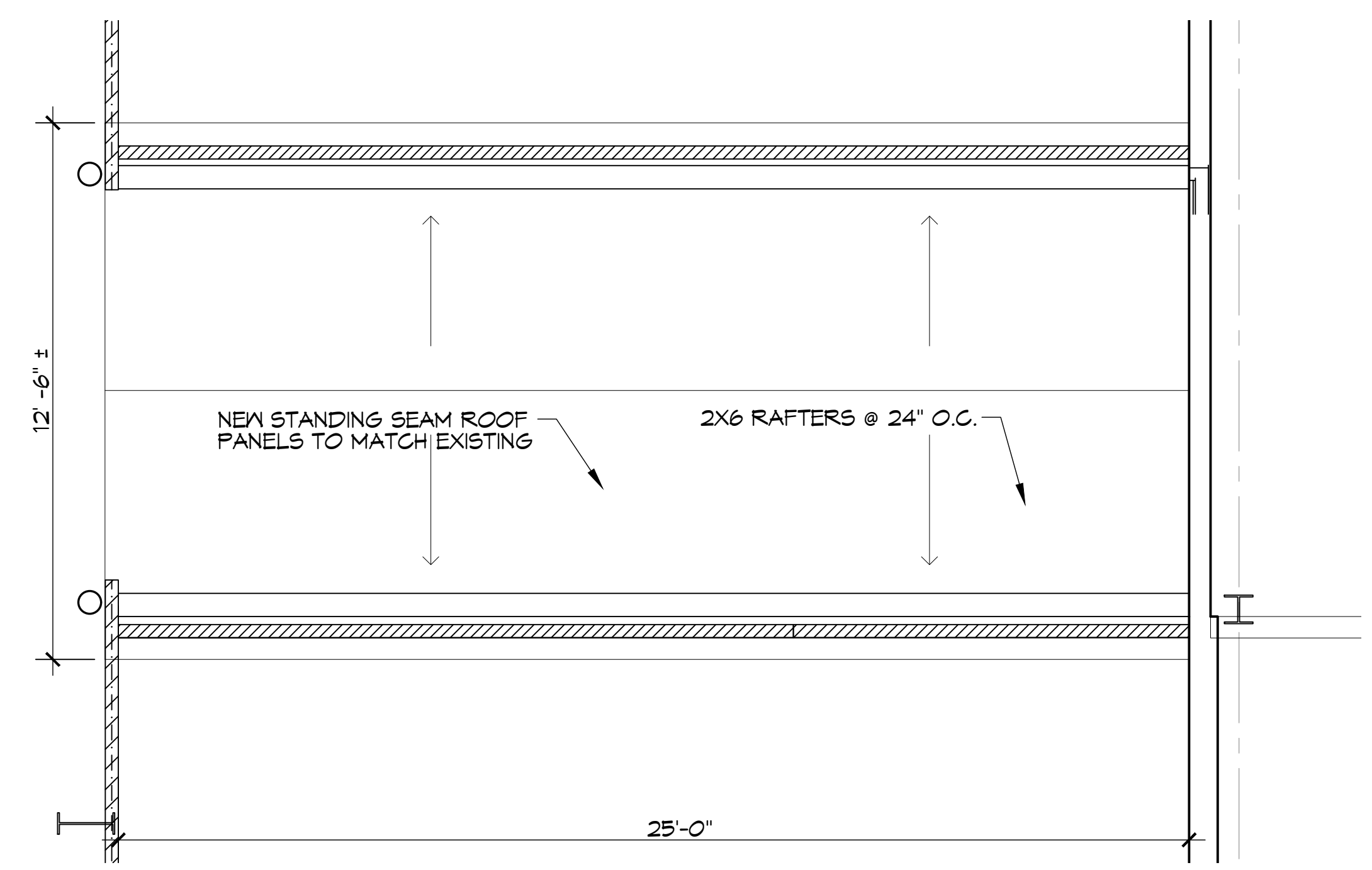

**9 CONNECTOR ROOF PLAN BLDG A - B**  
SCALE: 1/4" = 1'-0"

**DAMMON ENGINEERING, INC.**  
LOUISIANA & MISSISSIPPI

www.dammonengineering.com  
info@dammon.com  
PH: 985.649.5832

Chief Engineer: Brian Mistich, PE  
5000 Highway 101, Suite 100  
Slidell, LA 70688

#	DESCRIPTION	DATE

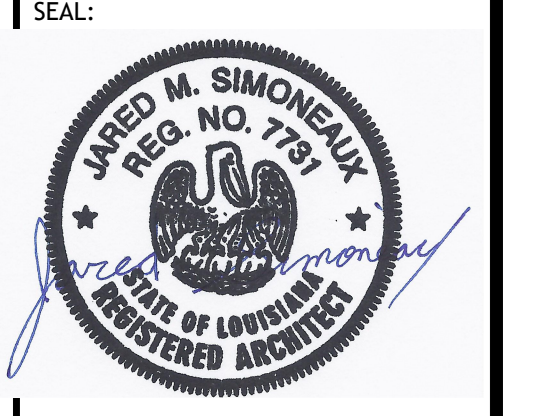

STAIR ADDITION  
**CROSSETTES CLUB**  
ATHLETIC CLUB

200 NORTH MILITARY ROAD  
SLIDELL, LA.

JOB No: 292T DATE: 08-08-24  
DRAWN BY: JLT. CHECKED BY: CACD

SHEET TITLE:  
BLDG A - B CONNECTOR  
SECTIONS AND ROOF  
PLAN

DRAWING NUMBER:

**A102**



**TABLE S601.7 - UPLIFT CONNECTIONS - 140 MPH WINDS EXP "C"**  
NFCM 2015 TABLE 9.2.4

CONNECTION	FRAMING SPACING (INCHES)	ROOF SPAN (FEET)	UPLIFT	ROOF SPAN (FT)	FRAMING SPACING (INCHES)	NUMBER OF 8d COMMON NAILS OR 10d BOX NAILS IN EACH END OF 1-1/4" X 20 GAGE STRAP
ROOF ASSEMBLY TO WALL ASSEMBLY; WALL ASSEMBLY TO WALL ASSEMBLY; WALL ASSEMBLY TO FOUNDATION	24	16"	4	24	16"	4
				24	24"	6

**TABLE S601.8 - SILL OR BOTTOM PLATE TO FOUNDATION CONNECTIONS RESISTING UPLIFT LOADS - 140 MPH WIND EXP "C"**  
NFCM 2015 TABLE 9.2.5

BOTTOM PLATE TO FOUNDATION ANCHOR BOLT CONNECTION RESISTING	FOUNDATION SUPPORTING	MAXIMUM ANCHOR BOLT SPACING (INCHES)	
UPLIFT LOADS	1 - 3 STORIES	8' END ZONES 30 INCHES ON CENTER	INTERIOR ZONES 35 INCHES ON CENTER

NOTE: A MINIMUM OF ONE ANCHOR BOLT SHALL BE PROVIDED WITHIN 6 TO 12 INCHES OF EACH END OF EACH PLATE

**TABLE S601.9 - BOTTOM PLATE TO FOUNDATION CONNECTIONS RESISTING SHEAR & LATERAL LOADS - ALL WINDS & ALL EXPOSURES**  
NFCM 2015 TABLE 9.2.6

ANCHOR BOLT DIAMETER (IN)	1/2" Ø ANCHOR BOLT	5/8" Ø ANCHOR BOLT
MAXIMUM ANCHOR BOLT SPACING (INCHES)	31 INCHES	43 INCHES

**TABLE S601.10 - FULL HEIGHT STUD REQUIREMENT FOR HEADERS OR WINDOW SILL PLATES IN EXTERIOR WALLS EXPOSURE B & C**  
NFCM 2015 TABLE 9.2.9C

HEADER SPAN (FEET)	WALL SPACING (INCHES)		
	12" O.C.	16" O.C.	24" O.C.
2	1	1	1
4	2	2	1
6	3	3	2
8	4	3	2

**TABLE S601.5 - JACK STUD REQ - INT LOADBearing WALLS**

HEADER SUPPORTING	HEADER SPAN (FT)	ROOF SPAN (FEET)													
		12 FEET				24 FEET				36 FEET					
		3"	4.5"	5"	6.5"	3"	4.5"	5"	6.5"	3"	4.5"	5"	6"		
ONE FLOOR ONLY (CENTER BEARING)	2	1	1	1	1	1	1	1	1	1	1	1	1	1	1
	4	1	1	1	1	1	1	1	1	1	1	1	1	1	1
	6	1	1	1	1	1	1	1	1	2	1	1	1	1	1
	8	1	1	1	1	2	1	1	1	2	2	2	1	1	1
	10	1	1	1	1	2	2	1	1	3	2	2	2	2	2
	12	1	1	1	1	2	2	2	1	3	2	2	2	2	2
TWO FLOORS (CENTER BEARING)	2	2	2	1	1	3	2	2	2	4	3	3	2	2	2
	4	1	1	1	1	2	1	1	1	3	2	2	2	2	2
	6	2	1	1	1	3	2	2	2	4	3	2	2	2	2
	8	2	2	1	1	3	2	2	2	5	3	3	3	3	3
	10	2	2	2	1	4	3	3	2	6	4	4	4	3	3
	12	3	2	2	2	5	3	3	3	7	5	4	4	4	4

**TABLE S601.6 - JACK STUD REQ - EXTERIOR LOADBearing WALLS**  
NFCM 2015 TABLE 9.2.2F

ROOF AND CEILING	HEADER SPAN (FT)	ROOF LIVE LOAD 20 PSF						ROOF LIVE LOAD 30 PSF							
		3"			5"			3"			5"				
		3"	4.5"	6.5"	3"	4.5"	6.5"	3"	4.5"	6.5"	3"	4.5"	6.5"		
ROOF AND CEILING	2	1	1	1	1	1	1	1	1	1	1	1	1	1	1
	4	1	1	1	1	1	1	1	1	1	1	1	1	1	1
	6	2	1	1	1	1	2	1	1	1	1	1	1	1	1
	8	2	2	2	2	1	2	2	2	2	2	2	2	2	2
	10	3	2	2	2	2	3	2	2	2	2	2	2	2	2
	12	3	2	2	2	2	3	2	2	2	2	2	2	2	2
ROOF, CEILING, AND ONE CENTER BEARING FLOOR	2	1	1	1	1	1	1	1	1	1	1	1	1	1	1
	4	2	1	1	1	1	2	1	1	1	1	1	1	1	1
	6	2	2	2	2	1	3	2	2	2	2	2	2	2	2
	8	3	2	2	2	2	3	2	2	2	2	2	2	2	2
	10	4	3	2	2	2	4	3	2	2	2	2	2	2	2
	12	4	3	3	2	2	5	3	3	3	3	3	3	3	3

**TABLE S601.3 - NAILING SCHEDULE**  
NFCM 2015 TABLE 3.1

DESCRIPTION	NUMBER OF COMMON NAILS	NUMBER OF BOX NAILS	SPACING
HEADER TO HEADER (FACE NAILED)	16d	16d	16" OC EDGES

**TABLE S601.4 - BUILDING ENVELOPE REQUIREMENTS**

ROOFS	OPAQUE ELEMENTS	ASSEMBLY MAXIMUM	INSULATION MIN. R-VALUE
ROOFS	INSULATION ENTIRELY ABOVE DECK	U-0.040	R-20.0 c.i.
	METAL BUILDING	U-0.065	R-19
	ATTIC AND OTHER	U-0.027	R-30
WALLS, ABOVE GRADE	MASS	U-0.151	R-5.7 c.i.
	METAL BUILDING	U-0.113	R-13.0
	STEEL-FRAMED	U-0.124	R-13.0
FLOORS	WOOD-FRAMED AND OTHER	U-0.089	R-13.0
	MASS	U-0.107	R-6-3 c.i.
	STEEL JOIST	U-0.052	R-19.0
SLAB-ON-GRADE	WOOD FRAMED AND OTHER	U-0.051	R-19.0
	UN-HEATED	F-0.750	NR
OPAQUE DOORS	SWINGING	U-0.700	NR
	NON-SWINGING	U-1.450	NR

**ROOF UNDERLAYMENT NOTES**

- FOR ROOF SLOPES FROM TWO UNITS VERTICAL IN 12 UNITS HORIZONTAL (17-PERCENT SLOPE), UP TO FOUR UNITS VERTICAL IN 12 UNITS HORIZONTAL (33-PERCENT SLOPE), UNDERLAYMENT SHALL BE TWO LAYERS APPLIED IN THE FOLLOWING MANNER:
  - APPLY A 14 INCH STRIP OF UNDERLAYMENT FELT PARALLEL WITH AND STARTING AT THE EAVES, FASTENED SUFFICIENTLY TO HOLD IN PLACE. STARTING AT THE EAVE, APPLY 36 INCH WIDE SHEETS OF UNDERLAYMENT, OVERLAPPING SUCCESSIVE SHEETS 14 INCHES, AND FASTENED SUFFICIENTLY TO HOLD IN PLACE.
- FOR ROOF SLOPES OF FOUR UNITS VERTICAL IN 12 UNITS HORIZONTAL (33-PERCENT SLOPE) OR GREATER, UNDERLAYMENT SHALL BE ONE LAYER APPLIED IN THE FOLLOWING MANNER:
  - UNDERLAYMENT SHALL BE APPLIED SINGLE FASHION, PARALLEL TO AND STARTING FROM THE EAVE AND LAPPED 2 INCHES, FASTENED SUFFICIENTLY TO HOLD IN PLACE. END LAPS SHALL BE OFFSET BY 6 FEET.

**SHINGLE APPLICATION & FASTENING NOTES**

- ASPHALT STRIP SHINGLES SHALL HAVE A MINIMUM OF SIX FASTENERS PER SHINGLE WHERE THE ROOF IS IN ONE OF THE FOLLOWING CATEGORIES:
  - THE BASIC WIND SPEED IS 110 MPH OR GREATER AND THE EAVE IS 20 FEET OR HIGHER ABOVE GRADE.
  - THE BASIC WIND SPEED IS 120 MPH OR GREATER.
  - SPECIAL WIND ZONES.

**METAL ROOF APPLICATION & FASTENING NOTES**

- INSTALL METAL ROOF PER MANUFACTURERS RECOMMENDATIONS FOR 150MPH WIND SPEED.

**GENERAL UPLIFT CONNECTION NOTES**

**ROOF ASSEMBLY TO WALL ASSEMBLY:** UPLIFT CONNECTIONS SHALL BE FROM RAFTER OR TRUSS TO WALL STUD, WHEN RAFTERS OR TRUSSES ARE NOT LOCATED DIRECTLY ABOVE STUDS, RAFTERS SHALL BE ATTACHED TO THE WALL PLATE AND THE WALL TOP PLATE SHALL BE ATTACHED TO THE WALL STUD WITH UPLIFT CONNECTIONS. UPLIFT CONNECTIONS SHALL BE IN ACCORDANCE WITH TABLE S601.10.

**WALL ASSEMBLY TO WALL ASSEMBLY:** STORY TO STORY UPLIFT CONNECTIONS FROM UPPER STORY WALL STUD TO LOWER STORY WALL STUD, WHEN UPPER STORY WALL STUDS ARE NOT LOCATED DIRECTLY ABOVE LOWER WALL STUDS, THE STUDS SHALL BE ATTACHED TO A COMMON MEMBER IN THE FLOOR ASSEMBLY BY UPLIFT CONNECTIONS. UPLIFT CONNECTIONS SHALL BE IN ACCORDANCE WITH TABLE S601.11.

**WALL ASSEMBLY TO FOUNDATION:** FIRST FLOOR WALL STUDS SHALL BE CONNECTED TO THE FOUNDATION, SILL, PLATE, OR BOTTOM PLATE. A MINIMUM OF A 1-1/4" X 20 GA. ASTM A653 GRADE 33 STEEL STRAP SHALL BE NAILED TO THE WALL STUDS AND HAVE A MINIMUM EMBEDMENT OF 7 INCHES IN CONCRETE FOUNDATIONS AND SLABS-ON-GRADE, 15 INCHES IN MASONRY BLOCK FOUNDATIONS, OR BE LAPPED UNDER THE BOTTOM PLATE. 3 INCH SQUARE WASHERS SHALL BE USED ON THE ANCHOR BOLTS AND ANCHOR BOLT SPACINGS SHALL NOT EXCEED THE REQUIREMENTS. STEEL STRAPS EMBEDDED IN OR IN CONTACT WITH SLAB-ON-GRADE OR MASONRY BLOCK FOUNDATIONS SHALL BE HOT-DIPPED GALV. AFTER FABRICATION, OR MANUF. FROM G185 OR Z450 GALV. STL. CONNECTIONS SHALL BE IN ACCORDANCE WITH TABLE S601.12.

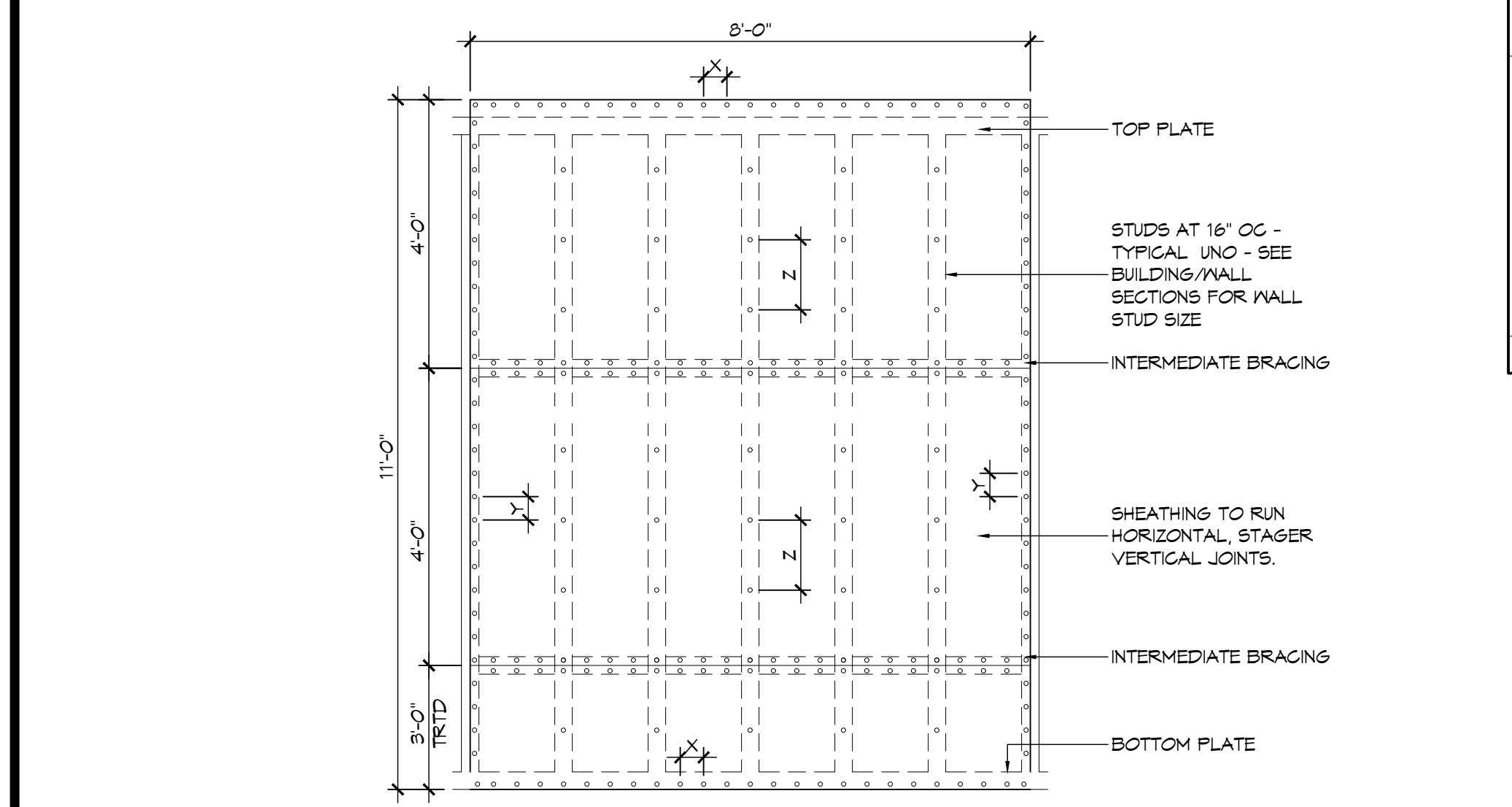

**NAIL SPACING**  
X = 4" OC  
Y = 4" OC  
Z = 12" OC

X = PLATE EDGE NAIL SPACING  
Y = LONG EDGE NAIL SPACING  
Z = FIELD NAIL SPACING

**INTERIOR SHEATHING**  
1/2" PLYWOOD EACH FACE STAGGERED 48" OC. W/8d NAILS @ 4" O.C. FASTENING @ PANEL EDGES 8d NAILS @ 12" O.C. FASTENING @ INTERMEDIATE MEMBERS.

**EXTERIOR SHEATHING**  
1/2" PLYWOOD EACH FACE STAGGERED 48" OC. W/8d NAILS @ 4" O.C. FASTENING @ PANEL EDGES 8d NAILS @ 12" O.C. FASTENING @ INTERMEDIATE MEMBERS.

**4 SHEAR WALL EXTERIOR SHEATHING NAILING PATTERN**

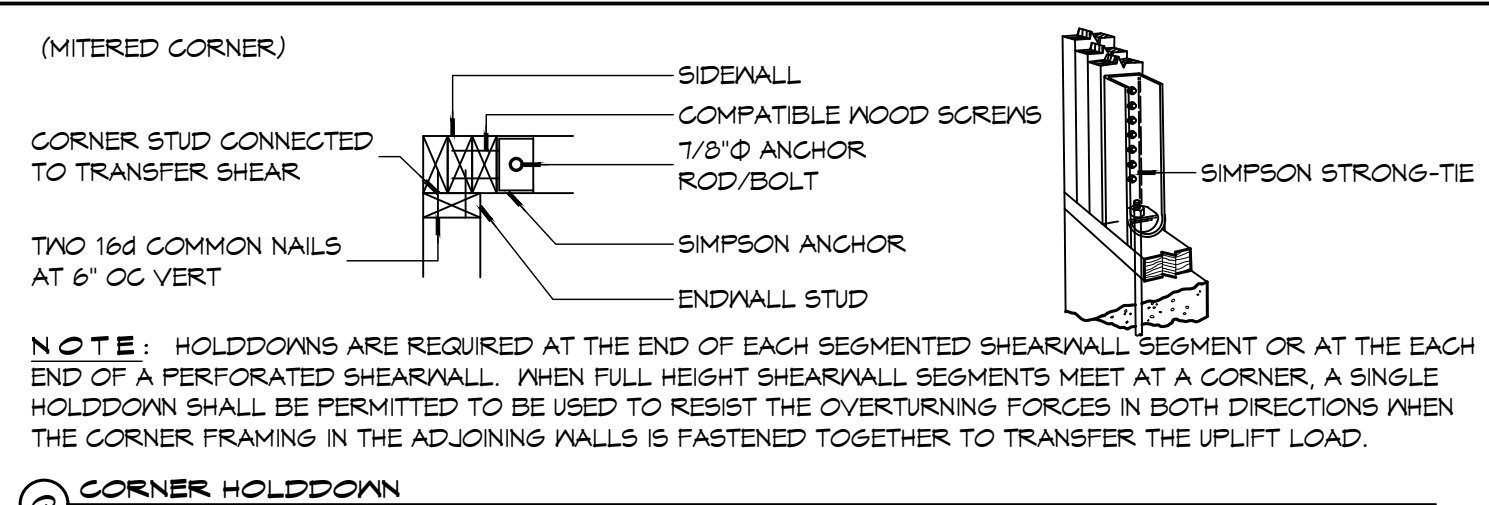

**5 CORNER HOLDDOWN**

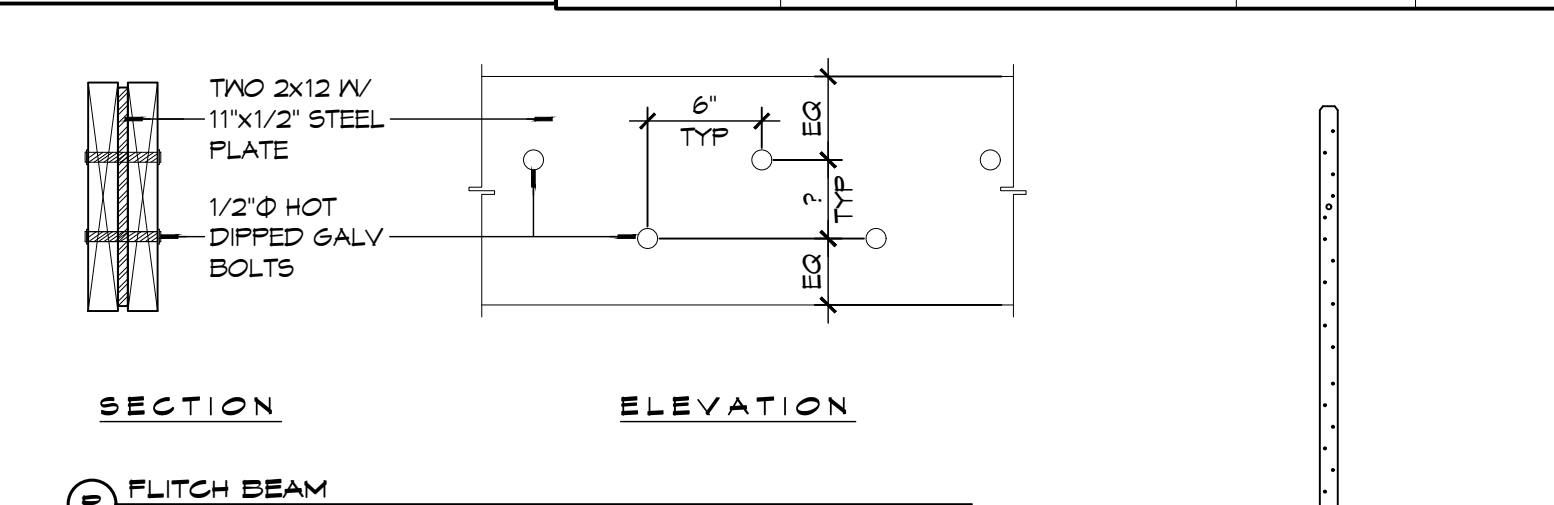

**6 FLITCH BEAM**

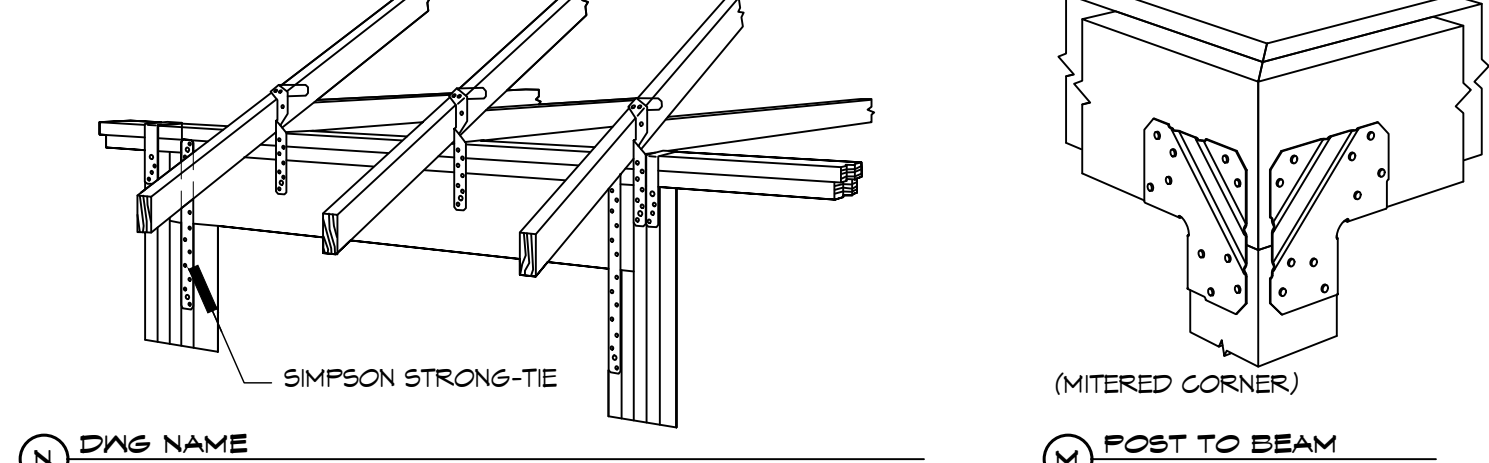

**7 POST TO BEAM**

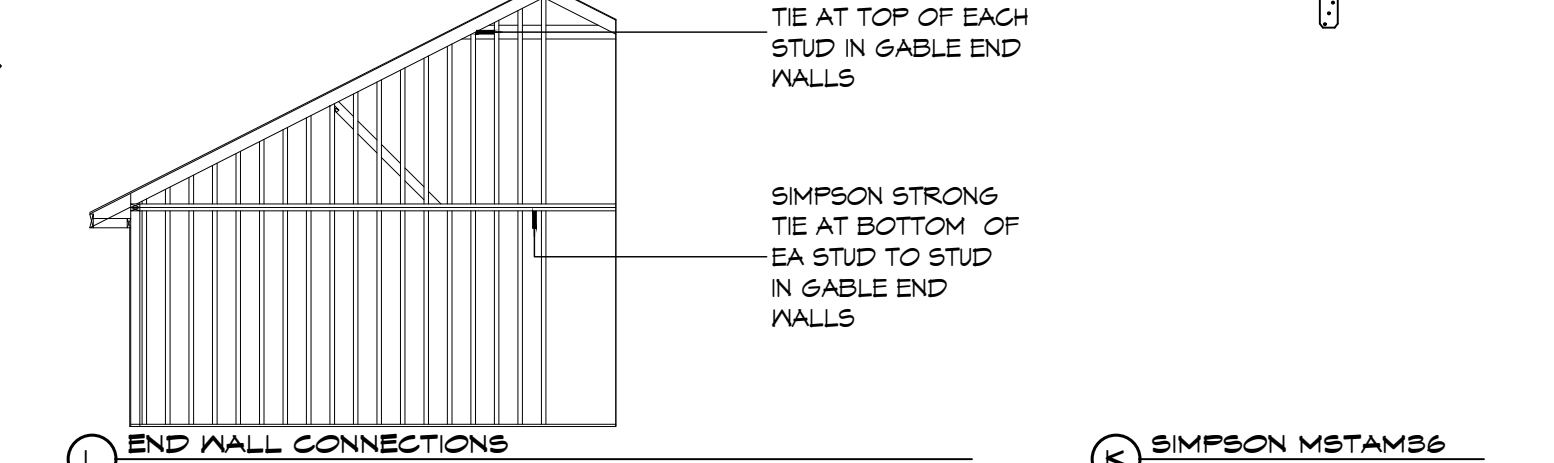

**8 SIMPSON MSTAMBS**

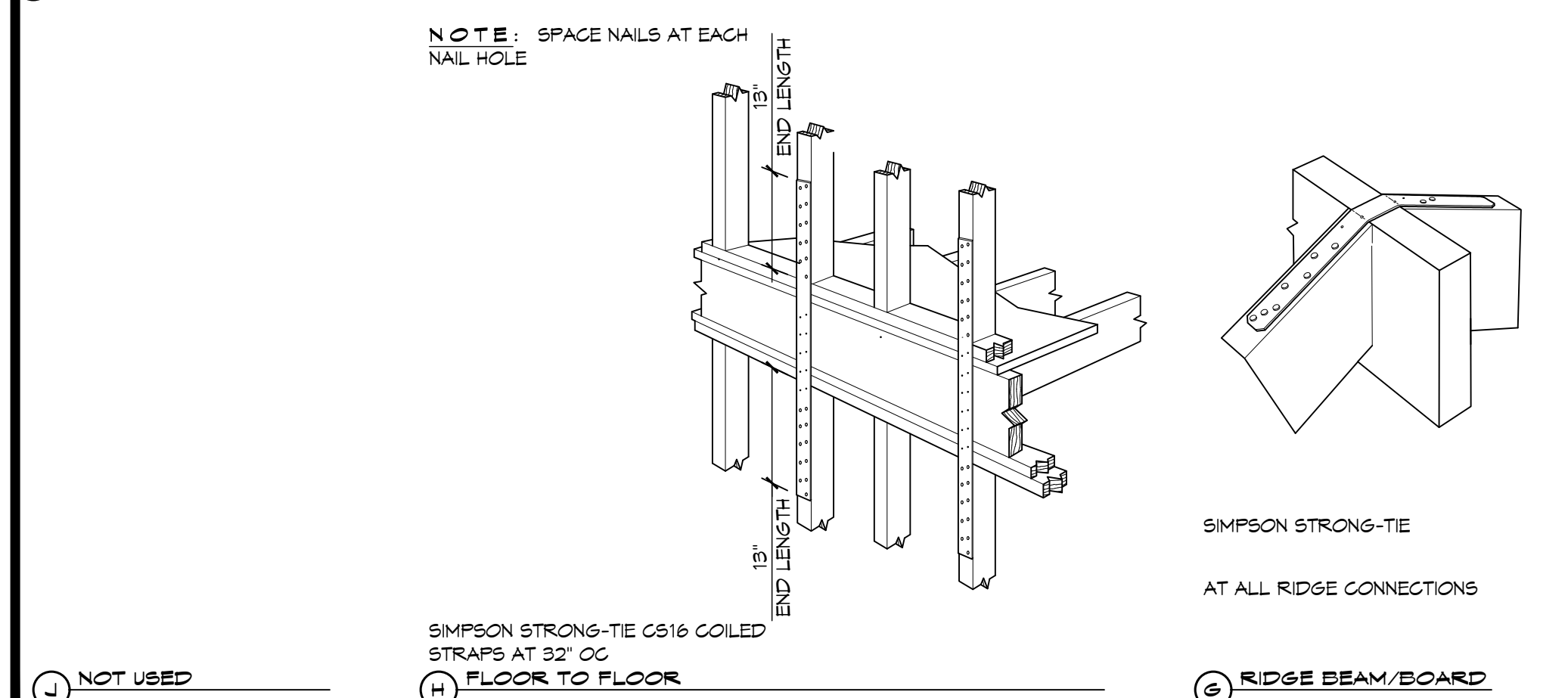

**17 TYPICAL CONNECTION DETAILS**  
SCALE: NTS

**TABLE S601.1 - ROOF SHEATHING ATTACHMENT REQUIREMENT - WIND LOAD EXP "C"**

SHEATHING LOCATION	RAFTER / TRUSS SPACING	E		F	
		MAX NAIL SPACING FOR 8d COMMON NAILS (INCHES OC)	10d BOX NAILS (INCHES OC)	MAX NAIL SPACING FOR 8d COMMON NAILS (INCHES OC)	10d BOX NAILS (INCHES OC)
INTERIOR ZONE	12" OC	6	12	6	12
	16" OC	6	12	6	12
	24" OC	6	12	6	12
PERIMETER EDGE ZONE	12" OC	6	6	6	6
	16" OC	4	4	4	4
	24" OC	3	3	3	3

150 MPH WIND - EXPOSURE "C" TYPICAL  
E = NAIL SPACING AT PANEL EDGES, INCHES.  
F = NAIL SPACING AT INTERMEDIATE SUPPORTS IN THE PANEL FIELD, INCHES.

**TABLE S601.1 - WALL SHEATHING AND CLADDING REQUIREMENT - WIND LOAD EXP "C"**

SHEATHING LOCATION	RAFTER / TRUSS SPACING	E		F	
		MAX NAIL SPACING FOR 8d COMMON NAILS (INCHES OC)	10d BOX NAILS (INCHES OC)	MAX NAIL SPACING FOR 8d COMMON NAILS (INCHES OC)	10d BOX NAILS (INCHES OC)
INTERIOR ZONE	12" OC	6	12	6	12
	16" OC	6	12	6	12
	24" OC	6	12	6	12
PERIMETER EDGE ZONE	12" OC	6	6	6	6
	16" OC	4	4	4	4
	24" OC	3	3	3	3

150 MPH WIND - EXPOSURE "C" TYPICAL  
E = NAIL SPACING AT PANEL EDGES, INCHES.  
F = NAIL SPACING AT INTERMEDIATE SUPPORTS IN THE PANEL FIELD, INCHES.

**DAMMON ENGINEERING, INC.**  
LOUISIANA & MISSISSIPPI

Chief Engineer: Brian Mischke, PE  
554 Old Spanish Trail  
Slidell, LA 70698  
www.dammonengineering.com  
info@dammonengineering.com  
PH: 985-649-5832

#	DESCRIPTION	DATE

SEAL: **JARED M. SIMONEAUX**  
REG. NO. 7751  
STATE OF LOUISIANA  
REGISTERED ARCHITECT

**STAIR ADDITION**  
**CURTAIN WALL**

200 NORTH MILITARY ROAD  
SLIDELL, LA  
JOB No: 2927  
DATE: 06-05-24  
DRAWN BY: JTL  
CHECKED BY: JTL

SHEET TITLE:  
TYPICAL CONNECTION DETAILS, SCHEDULES, AND NOTES

DRAWING NUMBER:  
**A103**

SHEET No: 7 of 8

**KEYED NOTES**

- 1. PROVIDE CONNECTION TO UN-SWITCHED HOT OF LIGHTING CIRCUIT AND SHALL HAVE 90 MINUTE EMERGENCY BATTERY BACKUP.

**LEGEND**

- EXIT LIGHT FIXTURE - CEILING MOUNTED
- EMERGENCY LIGHT - WALL MOUNTED
- JUNCTION BOX
- 1X4 FLUORESCENT FIXTURE

**GENERAL LIGHTING NOTES**

- ALL WORK SHALL COMPLY WITH APPLICABLE NATIONAL, STATE, AND LOCAL CODES, RULES, REGULATIONS, AND REQUIREMENTS OF THE SERVICE UTILITY COMPANY.
- GENERAL CONTRACTOR SHALL NOTIFY THE ARCHITECT IMMEDIATELY IF ANY CONFLICTS OCCUR BETWEEN LIGHTING AND ANY OTHER TRADE. DO NOT PROCEED WITH INSTALLATION IN THAT AREA UNTIL CONFLICT HAS BEEN RESOLVED TO THE SATISFACTION OF THE ARCHITECT AND ENGINEER.
- REFER TO ARCHITECTURAL DRAWINGS FOR EXACT LOCATION AND MOUNTING INSTRUCTIONS FOR ALL LIGHT FIXTURES. NOTIFY THE ARCHITECT AND ENGINEER OF ANY DISCREPANCIES BETWEEN THESE PLANS AND THE ARCHITECTURAL PLANS RELATING TO QUANTITY, TYPE AND LOCATION OF DEVICES AND/OR FIXTURES.
- WHEN SPECIFIC LIGHT FIXTURE HAS BEEN SPECIFIED IN THE FIXTURE SCHEDULE, ELECTRICAL CONTRACTOR SHALL PROVIDE COMPLETE ASSEMBLY INCLUDING ALL PARTS AND HARDWARE TO INSURE PROPER FUNCTIONING FIXTURE.
- ALL CONDUCTORS SHALL BE A MINIMUM OF #12 AWG UNLESS NOTED OTHERWISE.
- ALL 120V RUNS LONGER THAN 60 FEET SHALL BE #10 AWG AND 277V RUNS LONGER THAN 150 FEET SHALL BE #10 AWG UNLESS NOTED OTHERWISE.
- ALL CONDUCTORS SHALL BE COPPER.
- WHERE CONDUCTOR SIZES ARE NOTED ON DRAWINGS, THAT WIRE SIZE SHALL BE THROUGH THE ENTIRE RUN UNLESS OTHERWISE NOTED.
- MOUNTED LIGHT SWITCHES 48" AFF UNLESS NOTED OTHERWISE ON ARCHITECTURAL DRAWINGS.
- WHERE MORE THAN ONE SWITCH OCCURS IN THE SAME LOCATION, THEY SHALL BE INSTALLED IN A GANG TYPE BOX UNDER ONE COVER PLATE. ALL GANGED SWITCHES SHALL HAVE A COMMON SEAMLESS FACEPLATE. EACH MULTI-GANGED BOX SHALL BE NO MORE THAN SIX (6) SWITCHES WIDE. WHERE MORE THAN SIX (6) SWITCHES ARE SHOWN AT ONE (1) LOCATION, ADDITIONAL MULTI-GANGED BOXES SHALL BE STACKED VERTICALLY AND THE WIDTH OF THE MULTI-GANGS SHALL BE AS EVEN AS POSSIBLE.
- EACH DIMMER SWITCH SHALL HAVE A WATTAGE RATING 25% HIGHER THAN THE TOTAL WATTAGE OF LIGHTS TO BE CONTROLLED BY THE DIMMER. DIMMER SIZES 600, 1000, 1500, AND 2000 WATTS, LUTRON NOVA T-STAR. WHERE SWITCHES ARE GANGED WITH DIMMERS, THE SWITCHES SHALL ALSO BE LUTRON NOVA T-STAR. FLUORESCENT AND LOW VOLTAGE DIMMERS SHALL BE LUTRON NOVA T-STAR.
- ALL EMERGENCY EXIT LIGHT FIXTURES SHALL HAVE 90 MINUTE BATTERY BACKUP WITH INTEGRAL TEST BUTTON AND SHALL BURN CONTINUOUSLY.
- ALL FLUORESCENT FIXTURES THAT UTILIZE DOUBLE-ENDED LAMPS AND CONTAIN BALLASTS SHALL BE PROVIDED WITH A DISCONNECTING MEANS IN ACCORDANCE WITH NEC 410.136.

**GENERAL POWER NOTES**

- ALL WORK SHALL CONFORM TO THE LATEST EDITION OF THE NATIONAL ELECTRICAL CODE, THE GOVERNING ELECTRICAL CODE AND ALL OTHER INSPECTION DEPARTMENTS HAVING JURISDICTION. OBTAIN CERTIFICATES OR APPROVAL WHERE REQUIRED. ELECTRICAL CONTRACTOR SHALL VERIFY ALL WIRE AND CONDUIT SIZES FOR MECHANICAL EQUIPMENT TO BE INSTALLED.
- ALL MATERIALS FURNISHED SHALL BE NEW AND SHALL BE U.L. LISTED.
- THE DRAWINGS INDICATE SIZE AND GENERAL LOCATION OF WORK. SCALE DIMENSIONS SHALL NOT BE USED. THE EXACT LOCATION OF ALL LIGHTING FIXTURES, RECEPTACLES AND TELEPHONE OUTLETS, ETC. SHALL BE DETERMINED BY ACTUAL CONDITIONS IN THE FIELD.
- PRIOR TO BIDDING, CONTRACTOR SHALL VISIT THE JOB SITE AND FAMILIARIZE THEMSELVES WITH THE EXISTING CONDITIONS.
- ELECTRICAL CONTRACTOR SHALL COORDINATE HIS WORK WITH OTHER TRADES AND WITH OTHER CONTRACTORS WHOSE WORK MAY AFFECT THIS INSTALLATION.
- ELECTRICAL CONTRACTOR SHALL COORDINATE INCOMING ELECTRICAL SERVICE WITH UTILITY COMPANY AND INCLUDE IN HIS BID ALL CHARGES AND FEES INCURRED IN MODIFICATIONS.
- ELECTRICAL CONTRACTOR SHALL COORDINATE THE TELEPHONE INSTALLATION WITH THE TELEPHONE COMPANY AND THE GENERAL CONTRACTOR.
- ELECTRICAL CONTRACTOR, BEFORE INSTALLING ANY OF THE WORK, SHALL SEE THAT IT DOES NOT INTERFERE WITH CLEARANCES REQUIRED FOR FINISHED COLUMNS, HUNG CEILINGS, PLASTER, PARTITIONS, WALLS, ETC. AS SHOWN IN THE ARCHITECTURAL DRAWINGS AND DETAILS. IF ANY WORK IS INSTALLED AND IT LATER DEVELOPS THAT SUCH DETAILS OR DESIGN CANNOT BE FOLLOWED, THE CONTRACTOR, AT HIS OWN EXPENSE, SHALL MAKE SUCH CHANGES IN THE WORK AS DIRECTED BY THE ARCHITECT, AS WELL AS TO PERMIT THE INSTALLATION OF THE ARCHITECTURAL WORK AS SHOWN ON THE PLANS AND DETAILS.
- PERFORM TEST REQUIRED BY THE OWNER OR THE ENGINEER IN CONNECTION WITH THE OPERATION OF THE ELECTRICAL SYSTEM IN THE BUILDING. ALL TESTS SHALL BE MADE IN ACCORDANCE WITH THE LATEST STANDARD OF THE IEEE AND THE NATIONAL ELECTRICAL CODE.
- MINIMUM CONDUCTOR SIZE SHALL BE #12, 600V INSULATION.
- MINIMUM SIZE CONDUIT SHALL BE 3/4" ELECTRICAL METALLIC TUBING (EMT) FOR INTERIOR USE, 3/4" SCHEDULE 80 PVC FOR EXTERIOR USE ABOVE GRADE AND 1" SCHEDULE 40 PVC FOR EXTERIOR USE BELOW GRADE, BURIED A MINIMUM OF 18" FOR NON-VEHICULAR TRAFFIC AREAS AND 36" IN VEHICULAR TRAFFIC AREAS. EMT SHALL BE USED WITH METAL STUD CONSTRUCTION AND ALL ASSEMBLY OCCUPANCIES. USE NMC IN WOOD CONSTRUCTION. CONTRACTOR SHALL INSTALL WIRING, CIRCUIT BREAKERS AND OTHER CIRCUIT COMPONENTS TO MATCH EQUIPMENT ACTUALLY INSTALLED.
- ALL 120V RUNS LONGER THAN 60 FEET SHALL BE #10 AWG AND 277V RUNS LONGER THAN 150 FEET SHALL BE #10 AWG UNLESS NOTED OTHERWISE.
- INSTALL GROUND FAULT RECEPTACLES AT RECEPTACLE LOCATIONS WITHIN 5' OF SINKS OR LAVATORIES, AND AT EXTERIOR LOCATIONS. EXTERIOR RECEPTACLES SHALL ALSO BE WATERPROOF. ALL RECEPTACLES IN THE WAITING AREA SHALL HAVE BE TAMPER PROOF.
- BONDING AND GROUNDING SHALL BE IN ACCORDANCE WITH NFPA 70-230-63, NFPA 250-23, 250-71 & 250-72.
- GROUND NEUTRAL IN ACCORDANCE WITH NFPA 70-250-230.
- FUSES SHALL BE ITT CLASS K5, 250 VOLT, 200,000 AMP INTERRUPTING CAP.
- PROVIDE SERVICES OF A FIRE/SMOKE DETECTION AND ALARM COMPANY TO DESIGN AND INSTALL ALARM SYSTEM TO MEET REQUIREMENTS OF THE STATE FIRE MARSHALL AND THE FIRE DISTRICT.
- EXTERIOR LIGHTING SHALL BE SHADED OR INWARDLY DIRECTED IN SUCH A MANNER SO THAT NO DIRECT LIGHTING OR GLARE IS CAST BEYOND THE PROPERTY LINE. THE INTENSITY OF SUCH LIGHTING SHALL NOT EXCEED ONE FOOT CANDLE AS MEASURED AT THE ABUTTING PROPERTY LINE.
- ALL ELECTRICAL, MECHANICAL AND PLUMBING PENETRATING FIRE PARTITIONS SHALL BE FIRE CAULKED. (PENETRATIONS THROUGH RATED CONSTRUCTION SHALL BE SEALED WITH A MATERIAL CAPABLE OF PREVENTING THE PASSAGE OF FLAMES AND HOT GASES WHEN TESTED IN ACCORDANCE WITH ASTM-E814.)
- VERIFY ELECTRICAL CONNECTIONS PER MANUFACTURER'S RECOMMENDATIONS.
- ALL BRANCH CIRCUITS SERVING PATIENT CARE AREAS SHALL PROVIDE AN EFFECTIVE GROUND-FAULT CURRENT PATH BY INSTALLATION IN A METAL RACEWAY SYSTEM OR A MEDICAL GRADE MC CABLE (NEC ART. 517.13(A & B)).

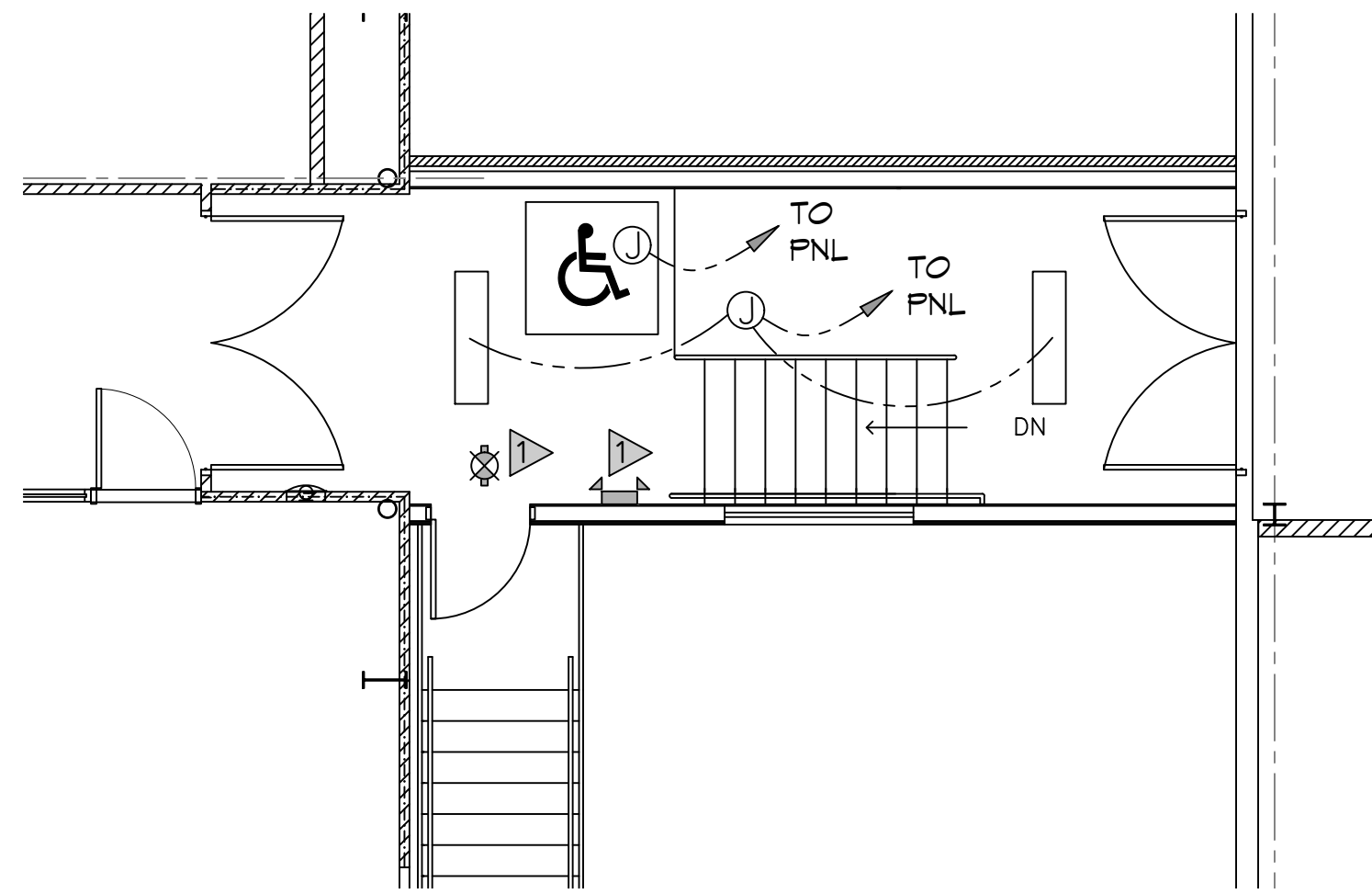

**11 POWER & LIGHTING PLAN 2ND FLOOR**  
SCALE: 3/16"=1'-0"

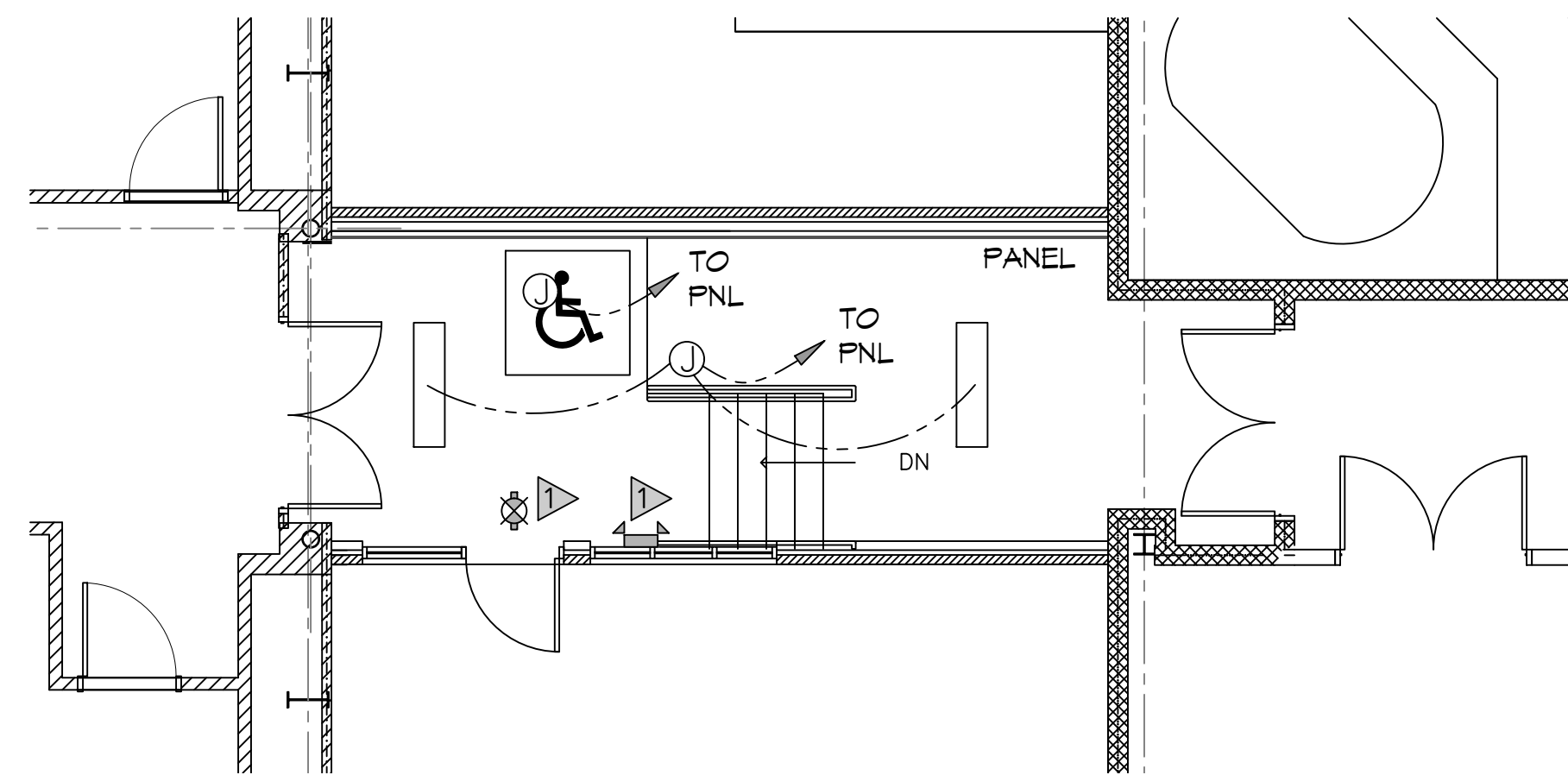

**12 POWER & LIGHTING PLAN 1ST FLOOR**  
SCALE: 3/16"=1'-0"

**DAMMON ENGINEERING, INC.**  
LOUISIANA & MISSISSIPPI

Chief Engineer: Brian Misch, PE  
Siddell, LA 70459  
www.dammonengineering.com  
info@dammonengineering.com  
PH: 985.649.9832

REVISIONS	DATE
#	DESCRIPTION



**STAIR ADDITION**  
**CROSSETTES CLUB**  
ATHLETIC CLUB  
200 NORTH MILITARY ROAD  
SLIDELL, LA  
JOB No: 2327 DATE: 05-08-24  
DRAWN BY: CKD CHECKED BY: BMM

SHEET TITLE:  
LIGHTING AND POWER PLAN

DRAWING NUMBER:

**E101**