

METAL BUILDING GUIDE

**205 Pallet Dr.
Harvey, LA 70058
504-368-5433**

DELTA Consolidated, LLC respectfully request to be accepted as an approved manufacturer on the above referenced project. Attached please find our submittal package which includes the following:

- Building General Specifications
- Sample Letter of Certification
- Sample Erection Drawings with Details
- Sample Panel Warranties

If any further information is required, or if you have any questions please call Steve Salassi at 504-368-5433. Thank you for your consideration on this matter.

Sincerely,

A handwritten signature in black ink, appearing to read 'Steve Salassi', with a horizontal line extending to the right from the end of the signature.

Steve Salassi



1. GENERAL

1.1 Scope

1.1.1 These specifications outline the design criteria, material quality, and fabrication processes used in the metal building systems designed, manufactured, and furnished by DELTA Consolidated, LLC .

1.1.2 These specifications are intended for use as an outline of the performance requirements for the various materials used by DELTA. They are further intended to insure that architects, engineers, builders, and/or owners understand the basis for design, manufacture and application of these materials.

1.1.3 Engineering and/or mechanical properties of materials utilized by DELTA in its product line are provided and/or referenced within these specifications, as are industry specification standards, where applicable.

1.1.4 DELTA utilizes those standards, specifications and/or interpretations and recommendations of professionally recognized groups and agencies, such as MBMA, AISC, AISI, AWS, ASTM, etc. as the basis in establishing its own design, fabrication and quality criteria, standards, practices, methods and tolerances. For convenience, certain provisions of a specification and /or recommendation of one of these groups or agencies (i.e. AISC, AISI, etc.) may be referenced, where appropriate, in DELTA documents. In all cases however, unless stipulated otherwise in the contract documents, DELTA's design, fabrication, quality criteria, standards, practices, methods, and tolerances will govern the work-and other interpretations to the contrary notwithstanding. DELTA buildings are fabricated in MBMA/IAS certified facilities.

1.1.5 Due to DELTA's policy of continuous product development and improvement, and due to changes in material availability, these specifications are subject to change without notice.

1.2 Materials Included

1.2.1 Standard material furnished by DELTA shall include primary and secondary structural framing members, bracing, metal panels for roofing and siding, trim, fasteners, sealants, accessories, and all other miscellaneous component parts required for a complete building (with the exception of anchor bolts and other embedded items).

1.3 Drawings and Calculations

1.3.1 DELTA shall provide erection information and drawings as required to assemble all parts, components, and accessories furnished by DELTA. Drawings shall include anchor bolt setting plans, roof framing plan, wall framing elevations, cross-sections, etc. and shall indicate piece marks of all major parts for easy field identification.

1.3.2 Anchor bolt setting plans will include column reactions for use in designing foundations for the building. However, DELTA shall not be responsible for the design of or the adequacy of the foundation.

1.3.3 If required by the contract documents, DELTA will furnish a letter of design certification for the structural framing and covering panels of the metal building system. Letter of certification will be signed and sealed by a registered professional engineer who is licensed in DELTA's home state where the building is designed and fabricated.

1.4 Building Nomenclature

1.4.1 The building "width" and "length" shall be measured from inside to inside of wall covering.

1.4.2 The building eave height shall be measured from bottom of primary frame base plate to top of the eave strut. The top of the eave strut is the point of intersection between the inside surfaces of the wall and roof covering.

1.4.3 The bay spacing shall be measured as follows:

- a. Interior bays from centerline to centerline of interior frames.
- b. End bays from inside of end wall sheets to centerline of first interior frame.

1.5 Building Description

1.5.1 DELTA buildings are designed to meet customers' exact requirements, therefore, the following information must be included in the contract documents in order to fully specify the building:

- a. Size (width, length, and eave height) specified to nearest 1/8 inch.
- b. Primary frame type (see below).
- c. Expandable or non-expandable end walls.
- d. Roof slope specified to nearest 1/8 inch.
- e. Side wall girt type (see Primary Frame types) and end wall girt type (see End Frame types).
- f. Bay spacing for interior bays and end bays specified to the nearest 1/8 inch (Bays may be equal or mixed).

1.5.2 Primary Frame Types:

Rigid Frame Clear Span: Primary frame shall be welded rigid frame design, clear span type, with single gable roof and pinned base columns. Columns shall be either tapered or straight as specified or required. Girts shall be By-pass or flush type.

Rigid Frame Multi-Span: Primary frames shall be welded rigid frame design, multi-span type (*use numerical digit to denote number of spans to be furnished), with single gable roof, pinned base side wall columns, and rafter supported at intervals by interior, pipe columns. Side wall columns shall be either tapered or straight as specified. Girts shall be By-pass or flush type.

Single Slope Clear Span: Primary Frames shall be welded rigid frame design, clear span type, with single slope roof and pinned base columns. Columns shall be either tapered or straight as specified. Girts shall be By-pass or flush type.

Single Slope Multi-Span: Primary frames shall be a welded rigid frame design, multi-span type, with single slope roof, pinned base side wall columns, and rafter supported at intervals by interior pipe columns. Sidewall columns shall be either tapered or straight as specified. Girts shall be By-pass or flush type.

Lean-to: Primary frames shall be post and beam design with high side of frame connected to and supported by the main building. Frame shall be clear span type with single slope roof. Columns shall be straight or tapered sections. Rafter shall be either a tapered beam or beam with parallel flanges as required by design. Girts shall be By-pass or flush type.

1.5.3 End Frame Types

a. Bearing End Frame: End Frames shall be a post and beam design with rafter pin connected at corner post continuous over, and supported by, end posts spaced at intervals along the end wall. Corner posts and end posts shall be designed as pinned both ends. Rafter, corner posts, and end posts shall be either hot-rolled mill sections, welded "H" built-ups, or cold-formed members. Girts shall be By-pass or flush type.

b. Rigid End Frame: End Frames shall be welded rigid frame of same type and design as Primary Frames in building. End posts shall be furnished to provide support for girts if a sheeted end wall is specified. End posts shall be either hot-rolled mill sections, welded built-up "H" shape, or cold-formed straight sections. Girts shall be By-pass or flush type.

2. DESIGN

2.1 General

2.1.1 All structural steel sections and welded plate members shall be designed in accordance with the applicable sections, relating to design requirements and allowable stresses, of the latest edition of the American Institute of Steel Construction (AISC) "Specification for the Design, Fabrication and Erection of the Structural Steel for Buildings."

2.1.2 All light-gauge, cold formed, structural members, and covering shall be designed in accordance with the applicable sections, relating to design requirements and allowable stresses, of the latest edition of the American Iron and Steel Institute (AISI) "Specification for the Design of Cold Formed Steel Structural Members."

2.2 Design Loads

2.2.1 Design load requirements shall be determined by local conditions, applicable codes, building end use, etc. Magnitude of design loads shall be specified by the contract documents. Application of design loads shall be in accordance with the Design Practices sections of the Metal Building Manufacturers Association (MBMA) 1996 "Low Rise Building Systems Manual", unless specified otherwise.

2.2.2 Loads to be considered are defined as follows:

- a. Dead Load: The weight of the building system materials.
- b. Collateral Loads: The weight of additional permanent materials, other than the building systems, such as sprinklers, mechanical and/or electrical systems, partitions, and ceilings.
- c. Roof Live Loads*: Loads that are produced 1) during maintenance by workers, equipment, and materials, and 2) during the life of the structure by movable objects. Live loads do not include snow, wind, seismic, or collateral loads.
- d. Roof Snow Loads*: The vertical load induced by the weight of snow, assumed to be on the horizontal projection of the roof of the structure (assumed to be 0.5 of ground snow unless otherwise specified).

* Note: Building system shall be designed for the live load or roof snow load specified, whichever governs.
- e. Wind Loads: The load caused by wind blowing from any horizontal direction (wind load may be specified as mph or as psf).
- f. Seismic Loads: The lateral load due to the action of an earthquake acting on the structure in any horizontal direction.
- g. Auxiliary Loads: Dynamic live loads such as those induced by cranes and material handling systems.
- h. Floor Live Loads: Those loads induced on a floor system by the use and occupancy of the building.

2.2.3 Specified design loads shall be considered to act in various combinations so as to produce the maximum effect on the building or structural member concerned. Unless otherwise specified, load combinations shall be those listed in the Design Practices section of the MBMA 1996 "Low Rise Building Systems Manual."

3. STRUCTURAL FRAMING

3.1 General

3.1.1 All framing members shall be shop-fabricated for bolted field assembly unless otherwise noted on erection drawings.

3.1.2 All framing members shall be cleaned of loose rust and loose mill scale by using the hand tool cleaning method SSPC-SP2 (Society for Protective Coatings) and given one shop coat of red color primer.

At DELTA's option, secondary structural framing may be cold-formed using pre-painted coil stock that eliminates the need for a shop coat of primer. Base metal shall be thoroughly cleaned then treated with iron phosphate solution to enhance paint adherence before coil is coated with a red oxide polyester paint. Paint dry film thickness shall be 0.5 mil on both sides.

3.2 Primary Members

3.2.1 Primary structural framing shall refer to the Primary Frames (transverse rigid frames and lean-to rafters/columns), expandable End Frames (rafters/corner posts/end posts), Wind/Seismic Bracing, and Crane Systems.

- a. Members fabricated from plate, plate coils, strip mill plate, or flat bar stock shall have flanges and webs joined by a continuous welding process. All material shall have a minimum yield strength of 50,000 psi. Material will conform to physical specifications of the following ASTM specifications: plate (ASTM A-572, Gr. 50); plate coils and strip mill plate (ASTM A-570, Gr. 50); and flat bar (ASTM A-36, Modified 50) and Covan 55.
- b. Members fabricated from W shapes (hot-rolled structural sections) will conform to the physical specifications of ASTM A-36, having a minimum yield strength of 36,000 psi.
- c. Members fabricated from other hot-rolled structural sections (S shapes/American Standard channels/angles/rods for anchor bolts/all other miscellaneous structural shapes) shall have a minimum yield strength of 36,000 psi and will conform to the physical specifications ASTM A-36.
- d. Interior columns of multi-span frames will be fabricated from round pipe column sections which have a minimum yield strength of 36,000 psi.
- e. Rods used for bracing will conform to the physical specifications of ASTM A-36 except that steel shall have a minimum yield strength of 50,000 psi.
- f. Cables used for bracing shall be zinc coated steel wire, extra high strength grade.
- g. Members fabricated by cold forming process shall have minimum yield strength of 55,000 psi and will conform to the physical specifications of ASTM A-570.

3.3 Secondary Members:

3.3.1 Secondary structural framing shall refer to purlins, girts, eave struts, base members, flange bracing, gable angles, clips, and other miscellaneous structural parts.

- a. Purlins, girts, eave struts, base members, and gable angles shall be cold formed from steel which has a minimum yield strength of 55,000 psi and will conform to the physical specifications of ASTM A-570.
 1. Purlins are roll formed "Z" sections, 8 inch or 10 inches deep. Each flange of these members has a stiffening lip formed at 50 degrees to the flange.
 2. Girts are either roll formed "Z" sections, 8 inch or 10 inches deep, or roll formed "C" sections, 8 inch or 10 inches deep. Each flange of these members has a stiffening lip formed at 50 degrees to the flange on "Z"s and at 90 degrees on "C"s.
 3. Eave struts are rolled formed "C" sections, 8 inch or 10 inches deep with 3 inch wide top and bottom flanges. Flanges are formed at angles other than 90 degrees to the web to accommodate various roof slopes. Each flange has a stiffening lip formed at 90 degrees to the flange.
- b. All other miscellaneous secondary members shall have minimum yield strength of 36,000 psi.

3.4 Connections

3.4.1 All field connections shall be bolted (unless otherwise noted).

a. All primary bolted connections, as shown on drawings, shall be furnished with high strength bolts conforming to the physical specifications of ASTM A-325. All high strength bolts and nuts shall be plated and coated with a zinc chromate dip for extended life and for easy identification.

b. All secondary bolted connections, as shown on drawings, will be furnished with machine bolts conforming to the physical specifications of ASTM A-307 unless ASTM A-325 bolts are required by design. Bolts and nuts for secondary connections shall also be plated for extended life.

3.4.2 All shop connections shall be welded using either submerged arc, gas metal arc, or shielded arc process. Welding shall be in accordance with the applicable sections, relating to design requirements and allowable stresses, of the latest editions of the American Welding Society "Structural Welding Code".

4. ROOF AND WALL COVERING

4.1 General

4.1.1 Standard covering for roofs or walls shall be ribbed-type panel having 36 inch net coverage. These panels shall be 26-gauge steel, with or without a painted coating. Panels without a painted coating shall be a galvalume finish.

4.1.2 Premium covering for roofs shall be standing seam panel having various net coverage depending on application. These panels shall be 24-gauge Galvalume steel with or without a color coating.

4.1.3 All panels shall be precision roll-formed to the required configuration specified.

4.1.4 Roof and wall panels of other materials and thickness' are available upon request.

4.2 Panel Materials

4.2.1 Galvalume is a specialty steel sheet product with a patented coating of corrosion-resistant aluminum-zinc alloy applied by a continuous hot dipping process. Typical coating weight is 0.5 oz. per square foot of coated sheet (both sides)-equivalent to approximately 0.8 mil thickness on each side. Galvalume steel panels shall have minimum yield strength of 80,000 psi unless otherwise specified under Item 4.33 (a), (b) and (c), and will conform to the physical specifications of ASTM A-924.

4.2.2 Color coated panels shall have the exterior side finished with a silicone polyester coating system applied over the Galvalume substrate. Surfaces shall be chemically cleaned, pre-treated, primed and coated, then oven-baked to cure. Total coating system shall have a one mil dry film thickness. Gloss rating for exterior shall be 20 to 35 except as specified under Item 4.3.2. The interior side of these panels shall be protected by a wash coat applied at 0.5 mil dry film thickness. Panels shall be coated prior to roll forming.

4.3 Panel Configurations and Finishes

4.3.1 Ribbed Wall Panels shall be R Panel having 1 ¼ inches deep major ribs which taper in width from 1 inch to 3 ¼ inches, and are spaced 12 inches on center. Between each major rib are two minor stiffening ribs. Each panel shall provide 3 feet of lateral coverage. Panel finish shall be Galvalume or any one of DELTA's standard panel colors.

4.3.2 Ribbed roof panels shall be PBR Panels having 1 ¼ inches deep major ribs which taper in width from 1 inch to 3 ¼ inches, and are spaced 12 inches on center. Between each major rib are two minor stiffening ribs. The "leading edge" rib has a bearing leg. Each panel shall provide 3 feet of lateral coverage.

4.3.3 Standing Seam Roof Panels

Standing seam roof shall be a trapezoidal panel design utilizing either fixed or sliding clips to allow thermal expansion. Panels shall be roll formed from 24 gauge material with 3 inch high major ribs spaced 24 inches on center with two interior minor stiffening ribs. Panels shall be designed so that the ribs interlock over the clips (mechanically seamed if required). DELTA's standing seam roof shall be considered a designed "system" requiring that all components be installed for proper product performance. Panel finish shall be galvalume or one of DELTA's standard colors. Weathertightness warranties also available when necessary.

4.4 Flashing, Trim and Closures

4.4.1 Flashing and/or trim shall be furnished at eaves, rake, corners, base, framed openings, personnel doors, and wherever necessary to seal against the weather and provide a finished appearance. Color shall be selected from DELTA's standard panel colors.

Profiles and dimensions of all flashing/trim will be DELTA's standards.

4.4.2 Eave gutters and downspouts may be specified as optional. Gutters have a face profile shaped to match rake trim. Downspouts are rectangular-shaped (4 inch x 3 inch standard size) and shall have a kick-out at the bottom. Color for gutter and downspouts shall be selected from DELTA's standard panel colors.

4.4.3 Color coated or Galvalume steel for flashing, trim, metal closures, gutter and downspouts, and other miscellaneous uses shall be 26 gauge thickness of the same specification as the roof and wall covering material.

4.4.4 Pre-formed, closed cell, polyethylene closure strips matching the profile of the panel shall be installed along the eave and at other locations to provide weather tightness when shown on DELTA's erection drawings.

4.5 Fasteners

4.5.1 Standard wall fasteners shall be No. 12 self-drilling fasteners with 5/16 inch flat top undercut head with EPDM sealing washer. Minimum length of fasteners shall be 1 ¼ inches for "panel to structural" application. Standard "stitch" screws shall be No. 14 self-drilling fasteners with 5/16 inch flat top undercut head with EPDM sealing washer with a length of 7/8 inch.

Fasteners shall be painted to match panel and/or trim color.

4.5.2 Standard roof fasteners shall be No. 12 self-drilling fasteners with 5/16 inch flat top undercut head with EPDM sealing washer that is compatible with Galvalume or color coated panels. Minimum length of fasteners shall be 1 ¼ inches for "panel to structural" application. Standard "stitch" screws shall be No. 14 self-drilling fasteners with 5/16 inch flat top undercut head with EPDM sealing washer with a length of 7/8 inch.

Fasteners shall be painted to match panel and/or trim color.

4.6 Sealants

4.6.1 Sealants for side laps, end laps, accessories, etc. shall be pre-formed, butyl rubber based compound. The material shall be non-hardening, non-shrinking and non-corrosive and shall have excellent adhesion to metals, painted surfaces and plastic at temperatures from - 30 degrees Fahrenheit to 160 degrees Fahrenheit. These sealants shall be in tape mastic form, of shape and size recommended by DELTA for various applications, and shall have paper backing for easy handling.

4.6.2 Tube sealants shall be used to supplement tape mastic sealants and shall be applied in locations indicated by erection instructions. Tube sealant shall be synthetic elastomer-based material, which becomes tack-free in less than 2 hours at 75 degrees Fahrenheit but retains flexibility.

4.7 Installation of Wall and Roof Panels

4.7.1 Wall panels shall be continuous from base to eave. If panel lengths exceed manufacturing and shipping limitations, splice end laps shall occur over a wall girt.

4.7.2 Roof panels shall be continuous from eave to ridge. If panel lengths exceed manufacturing and shipping limitations, splice end laps shall occur at a roof purlin. Sealant shall be used in all roof panel end laps.

4.7.3 When specified, all ribbed, roof panel side laps shall be sealed with a field applied, continuous ribbon of tape mastic sealant. Eaves shall also be sealed when specified.

4.7.4 Fastener spacing for both wall and roof panels shall be as shown on erection details.

5. ACCESSORIES

5.1 Personnel Doors

5.1.1 Personnel (walk) door leaves shall be DELTA's standard, full flush hollow metal doors, 1 ¾ inches thick with 20-gauge, G-60 galvanized skins over a Poly-Styrene core. Leaf shall be reversible to work with non-handed door frames.

5.1.2 Personnel (walk) door frames shall be DELTA's non-handed (reversible) frames, 6 ¾ inches deep with a 2 inch wide face, 16-gauge, G-60 galvanized steel with square cut, butted corners. Jambs and headers are of knockdown type for field assembly through bolted connections. Door frame shall be an open "C" section to "wrap-around" end of 8 inch girts.

5.1.3 Personnel door sized shall be 3070 (single), 4070 (single), or 6070 (double). In addition to size, doors shall be designated as M (solid leaf), G (half glass; 23 inch x 29 inch nominal size), or LV (long vision glass; 6 inch x 54 inch nominal size). Tempered glass provided.

5.1.4 Hardware furnished with all doors shall consist of leaf, frame (knocked down), assembly bolts, plain bearing hinges, standard knob lockset, threshold, jamb and head trim, and screws. In addition to these items, Double Leaf Doors will include two surface bolts, handed astragal, and a lock hole filler plate.

Optional hardware is available upon request.

5.1.5 Doors specified shall be:

Sizes	3070 and 4070 (single) 6070 (double)
Leaf Styles	M, G, and LV
Core: (typical)	Poly-Styrene
Factory Paint (door & frame)	White, primer coat
Surface texture (door/frame)	Embossed/smooth
Lockset: (typical)	Standard
Weather-stripping kit	Standard

5.2 Horizontal Sliding Windows

5.2.1 Aluminum windows shall be single slide (horizontal) type, with pre-glazed clear glass, removable half screen, latching device, and weather-stripping. (**Vertical Slide Windows available upon request.**) Window extrusions shall have self-trimming mounting fins for connecting to wall covering.

5.2.2 Single windows shall be 3030, 3040, 4030, 4040, 5030, 5040, 6020, 6030, or 6040 nominal size. Double or multiple windows can be by joining the window jamb fins together, and adding a reinforcing mullion.

5.2.3 Glass is clear DSB grade. Screens for windows shall be fiberglass mesh (dark bronze color) in an aluminum frame (finish to match window finish).

5.2.4 All Structural members shall be extruded aluminum, assembled with screws and sealed at junctions. Window construction shall conform to AAMA (American Aluminum Manufacturers Association) Specification A-1, Class II.

5.2.5 Windows may be specified in either "Standard" or "Premium" quality. Differences are as follows:

<u>Standard</u>	<u>Premium</u>
Mill Finished Aluminum	Bronze Painted Aluminum
Single or Insulated	Single or Insulated

5.3 Fixed Glass Windows

5.3.1 Aluminum, strip windows shall be self-flashing type with mounting fins and Snap-On trim. Frame members shall be extruded aluminum sections 2 ½ inches deep with .055 inch wall thickness. Unit shall have a burnished slate finish and shall be pre-glazed.

5.3.2 Strip window units available in 1070, 2060, and 2070 nominal size.

5.3.3 Window shall be 1/8 inch, gray tinted tempered fixed glass available in Single Pane or Insulated.

5.3.4 Window unit shall be assembled with screws and sealed at junctions. Construction shall conform to AAMA (American Aluminum Manufacturers Association) Specification A-1, Class II.

5.4 Wall Louvers

5.4.1 Wall louvers shall be fixed or adjustable. All louvers are fabricated with permanent mounting fins to fit specified panel. Width of louver is measured center-to-center of mounting fins. All louvers are self-framing and require no additional flashing or trim.

5.4.2 Louvers are available in the following sizes: 3030, 4030, 4040, 5030, 6030, or 6040.)

5.4.3 Louver shall be made of galvanized steel. Frame shall be 16-gauge and blades shall be 26-gauge material. Frame joints will be welded. Blades will be overlapping type, providing maximum weather tightness when closed and allowing free airflow when open.

5.4.4 Screen shall be 18/16 aluminum or fiber mesh in an extruded or formed aluminum frame. Screens will be exterior mounted. Louvers may be specified in either "Standard" or "Premium" quality. Differences are as follows:

<u>Standard</u>	<u>Premium*</u>
Finish on Frame/Blades: Galvanized	Burnish Slate, Polar White, Sahara-Tan, Aztec Gold, and Light Stone.

*Finish coating of polyester paint applied over galvanized steel.

5.5 Framed Openings

5.5.1 Framed openings shall be furnished by DELTA to accommodate Overhead Doors or Roll-up Doors supplied by others. Framed openings shall consist of structural framing to provide a large opening in a wall, along with necessary trim to flash around this opening and provide a finished appearance.

5.5.2 Size of opening shall be determined by size of door specified. Structural framing (jamb and header) shall consist of cold-formed, open "C" sections (8 inch or 10 inches deep) or hot rolled channel sections. Necessary clips and fasteners, for making connections for all members, shall be provided. Trim around opening shall be DELTA's standard to accommodate wall panel configuration. (Door track supports by door supplier).

5.5.3 Color-coated trim to entirely cover shop-primed structural jambs and header may be specified as optional.

5.6 Translucent Panels (Wall)

5.6.1 Wall lights shall be General Purpose, type I, translucent panels manufactured from polyester resin reinforced with chopped glass fibers. These panels shall have the same configuration as the ribbed wall panels specified.

5.6.2 Panels shall have a minimum weight of 8 ounces per square foot. Exterior face will have a pebble texture, and color will be white. Light transmittance is 46%.

5.6.3 Each panel shall provide 3 feet of lateral coverage. Minimum length panel available is 10 feet, 8 inches. Installation of translucent wall panel is similar to that of steel panels.

5.7 Translucent Panels (Roof)

5.7.1 Roof lights shall be General Purpose, type I, translucent panels manufactured from polyester resin reinforced with a mesh of woven fiberglass cloth in addition to chopped glass fibers. These panels shall have the same configuration as the roof panels specified.

5.7.2 Panels shall have a minimum weight of 8 ounces per square foot. Exterior face will have a pebble texture, and color will be white. Light transmittance is 46%.

5.7.3 Ribbed translucent panels shall provide 3 feet coverage. Minimum length of panel available is 10 feet, 8 inches. Installation of translucent roof panels is similar to that of steel ribbed panels.

5.7.4 Roof lights for the SSR roof shall be insulated only and specially fabricated using metal side ribs to seam into standing seams of adjacent, steel panels. The roof light assembly shall provide 2 feet of coverage. Standard length panel available is 10 feet, 2 inches. Installation of assembly is similar to that of steel SSR panels.

5.8 Roof Curbs (For Equipment)

5.8.1 Roof curbs shall be a one piece unit consisting of a top box, or shell, and bottom skirt, or flange. Units shall be of welded construction, and tops of shell provide a level surface for supporting roof mounted equipment.

5.8.2 Each unit shall be individually sized and design to meet specific job requirements. Roof slope must be specified so that curb base will be fabricated to match. Curb shell is insulated.

5.8.3 Roof curbs shall be made using 16-gauge, G-90 galvanized steel for shell and flange and shall have internal angle reinforced as required. Painted (white) units, to match color coated roof panels, are available.

5.8.4 Roof curbs are supported by structural sub-framing and are installed with flange under roof panels. Roof panels are fastened to the flange with sealant and screws to provide a weather tight assembly.

5.9 Pipe Flashing

5.9.1 Pipe flashing unit shall be a one piece construction that accommodates pipes made of steel, copper, cast iron, PVC and sheet metal.

5.9.2 Unit may be specified in sizes ranging from ¼ inch to 26 inches.

5.9.3 Units shall be made of a flexible rubber compound (EPDM or equal) formulated to provide maximum weather tightness. Unit shall be pre-molded to form a pipe collar. Bonded to base of collar shall be a 1/32 inch plus or minus, moldable aluminum ring that bends with ease to conform to any panel configuration.

5.9.4 Pipe flashing units shall be furnished with necessary sealant and screw fasteners to attach unit to roof panels and provide a weathertight assembly.

5.9.5 These units are not to be used as flashing for any hot glue applications where temperatures exceed 150 degree Fahrenheit.

5.10 Insulation

5.10.1 Insulation shall be blanket type, fiberglass with vapor barrier facing, suitable for application to walls and roof of metal buildings.

5.10.2 The insulation shall be made of long and fine fiber fiberglass, evenly distributed and of uniform density, bonded with phenolic thermo-setting resins. This product conforms to the North American Insulation Manufacturing Association (NAIMA) Standard 202-96, Underwriters Laboratories Hazard Class 25/50. Standard insulation designations, nominal thickness', and thermal resistance (R) factors are as follows:

<u>Insulation Designation</u>	<u>Nominal Thickness</u>	<u>"R" Value</u>
R10	3 inch	10
R13	4 inch	13
R19	6 inch	19

Width of fiberglass blanket should be specified (48 or 72 inches). 36 and 60 inch is available upon request.

5.10.3 Vapor barrier facing shall be a vinyl reinforced polyester (WMP-VR) film (3 mil approximate thickness), and shall have an Underwriters Laboratories flame spread rating of 25 or less* and a smoke developed rating of 50 or less. Water vapor transmission value is .09 perms for WMP-VR facing. Color of facing material shall be white and width shall be 78 inches so as to provide a 6-inch tab projecting beyond one side of the fiberglass blanket. Vinyl reinforced polyester facing is recommended when air temperatures of 40 degrees Fahrenheit or below are anticipated during shipment or erection.

*Note: The numerical flame spread rating is not intended to reflect hazards presented by this or any other material under actual fire conditions.

5.10.4 Blanket type insulation shall be installed on roof and/or walls between exterior panels and secondary framing members (purlins and girts).

5.10.5 Insulation with other vapor barrier facings and/or in widths other than 48 or 72 inches can be furnished upon special request.

6. BUILDING FOUNDATION

6.1 Anchor Bolts

6.1.1 Anchor bolts shall be furnished by others and shall be set in strict accordance with DELTA's anchor bolt drawings. Anchor bolts shall be of length and strength to properly resist the governing reactions induced by the design loads and shall be of the diameter shown on DELTA's anchor bolt drawings. All anchor bolts shall be unpainted so as to bond with the concrete in which they are set.

6.2 Foundations

6.2.1 The building foundation shall be designed by a qualified engineer to support the metal building and all other loads required by the occupant's usage. DELTA's anchor bolt drawings shall show column reactions to be used for designing the buildings foundation. DELTA shall not be responsible for the design or adequacy of the foundation provided.

7. BUILDING ERECTION

7.1.1 The erection of DELTA structures shall be in accordance with applicable erection drawings.

7.1.2 Erection shall be performed by a qualified erector using proper tools and equipment. It shall be the responsibility of the erector to comply with all applicable legal and safety requirements. It shall further be the responsibility of the erector to determine and provide any and all temporary bracing, bridging, blocking, shoring, and/or securing of components, etc. as required for stability during the entire erection process.

7.1.3 Erector shall not make any field modifications to any structural member except as authorized and specified by DELTA.

8. WARRANTIES

8.1 Material and Workmanship Warranties

8.1.1 DELTA shall furnish a one (1) year limited warranty against failures caused by faulty or substandard materials.

8.2 Wall Paint Warranties

8.2.1 All DELTA's paint coated wall panels may be warranted, within limits set by the warranty, for a period of thirty (30) years for film integrity, and twenty-five (25) years against chalking and fading. DELTA's suppliers offer these warranties, and copies of these warranties are available upon request.

8.3 Roof Paint Warranty

8.3.1 DELTA's paint coated roof panels may be warranted, within limits set by the warranty, for a period of thirty (30) years for film integrity, and twenty-five (25) years against chalking, and fading. DELTA's suppliers offer these warranties, and copies of these warranties are available upon request.

8.4 Roof/Wall Material Warranty (Galvalume Panels)

8.4.1 Unpainted Galvalume roof/wall panels may be warranted, within limits set by the warranty, for a period of twenty (20) years against rupture, perforation and structural failure. This twenty (20) year warranty is available only if panels are installed using approved fasteners. DELTA's suppliers offer this warranty, and a copy of this warranty is available upon request.

8.5 Warranty Limits

8.5.1 All warranties are subject to certain limits and conditions. Specimen copies of any or all warranties may be obtained by contacting DELTA. These specimen copies and sample copies specifically state the limits and conditions of each warranty.

Letter of Certification

29075DELTA

Saturday, August 15, 2009

RE: Project Description: 30 x 40 x 12 x 3;12 Slope
End Use Code: 2-(All Others)
Building Code: 2006 International Building Code
Design Codes: AISC, 13TH Edition (ASD), 2001 AISI

Gentlemen:

This letter is to certify that the above referenced project and its components have been designed to meet or exceed the requirements for the design code and specifications shown above.

Based on the requirements of the order documentation, the structural design criteria applied to the design of this project are as follows:

Basic Loading		Seismic Loading	
Roof Live: 20.00 Psf	Live Load Reduction: Yes	Seismic Zone: N/A	Importance Factor: N/A
Collateral: 1.00 Psf		Short Period Accel, Ss: 12.80	Response Mod Fac, R: 3.00
Snow: 0.00	Snow Type: N/A	1 Second Accel, S1: 5.60	Deflection Amp Fac, Cd: 3.00
Wind Velocity: 130.00 Mph	Concrete Stress: 3000	Seismic Haz Exp Group: G1	Soil Profile Type: D

Wind Exposure Condition		Snow Exposure Condition	
Exposure: B	Coastal Zone: No	Roof Snow Exp: C	Thermal Exp: ABOVE FREEZING
Building Envelope: FULLY CLOSED		Surface Condition: OTHER	Surface Exp: PART EXPOSED
Importance Factor: 1.0000		Importance Factor: 1.0000	

This certification is limited to the steel framework, the metal roof, the wall covering, and fasteners required for their installation. This certification specifically excludes the design and analysis of the foundation, masonry walls, masonry anchors, and parts supplied by anyone other than the building manufacturer.

Note: Failure due to wind of doors not supplied by the building manufacturer relieves the building manufacturer of ALL responsibility for the building stability.

Respectfully Submitted,

GALVALUME 20 YEAR WARRANTY

Delta Consolidated, LLC warrants that hot-dipped aluminum-zinc alloy coated Galvalume steel sheets sold as Delta Rib, M, Horizon-Loc, PBR-Loc, for use as steel building roofing and siding panels, if erected in the United States, will not rupture, fail structurally or perforate within a period of twenty (20) years after shipment due to exposure to normal atmospheric corrosion.

This warranty DOES NOT APPLY to sheets exposed at any time to corrosive or aggressive atmospheric conditions, including but not limited to:

- Areas subject to salt water marine atmospheres or to constant spraying of either salt or fresh water.
- Areas subject to fallout or exposure to corrosive chemicals, ash or fumes.
- Areas subject to water run-off from lead or copper flashing or areas in metallic contact with lead or copper.
- Conditions/circumstances where corrosive fumes or condensates are generated or released inside the building.

This warranty DOES NOT APPLY in the event of:

- Mechanical, chemical or other damage sustained during shipment, storage, erection, or after erection.
- Failure to provide free drainage of water, including internal condensation from overlaps and all other surfaces of the sheets or panels.
- Failure to remove debris from overlaps and all other surfaces of the sheets or panels.
- Damage caused to the metallic coating by improper scouring or cleaning procedures.
- Deterioration of the panels caused by contact with green or wet lumber, or storage stain caused by water damage or condensation.
- Presence of damp insulation or other corrosive materials in contact with or close proximity to the panel.
- Deterioration of the panels caused directly or indirectly by panel contact with fasteners. Selection of suitable long-lasting fasteners to be used with Galvalume roofing and siding panels rests solely with the Buyer.
- A degree of bending less than 2T for sheet gauges up to 0.030 in. and degree of bending less than 4t for sheet gauges 0.031 in. and thicker.
- Slopes of roof or sections of the roof flatter than ¼:12.

This warranty shall be subject to the stipulations, limitations and conditions hereinafter set forth.

The remedy for any claims on steel roofing and siding panels shall be at the discretion of Delta Consolidated, LLC and shall be limited to refinishing or replacing the defective panels.

DELTA CONSOLIDATED, LLC SHALL NOT BE LIABLE FOR ANY LOSSES, DAMAGES OR EXPENSES WHETHER DIRECT, INCIDENTAL OR CONSEQUENTIAL, CAUSED BY OR RESULTING FROM THE USE OF DEFECTIVE OR NON-CONFORMING STEEL ROOFING AND SIDING PANELS OR FOR ANY OTHER INCIDENTAL OR CONSEQUENTIAL DAMAGES.

DELTA CONSOLIDATED, LLC'S TOTAL LIABILITY IS EXPRESSLY LIMITED TO THE PURCHASE PRICE OF THE STEEL ROOFING AND SIDING PANELS.

Some states do not allow the exclusion or limitation of incidental or consequential damages, so this limitation or exclusion may not apply in your state. This warranty provides specific legal rights and other rights which vary from state to state that may apply.

Delta Consolidated, LLC's liability for the breach of this warranty shall be limited exclusively to the cost of either repairing non-conforming, rupturing, perforating or structurally failing panels, or at Delta's sole option, of furnishing FOB Buyer's plant sufficient sheet product to enable Buyer to fabricate replacement panels for the non-conforming, rupturing, perforating or structurally failing panels. Delta shall not in any event be liable for the cost of labor expended by others on any non-conforming, rupturing, perforating or structurally failing sheet or for any special, indirect, or consequential loss of profits or any other incidental, general, special or compensatory damages to anyone by reason of the fact that such panels shall have been non-conforming, rupturing, perforating, or structurally failing.

Claims under this warranty must be made in writing to Delta Consolidated, LLC at the address set forth below within 30 days after discovery of the defect. Delta shall have an additional 30 days to inspect the steel roofing and siding panels before any further action shall be taken.

Adequate identification of material involved in the claim, including date of installation, order number, invoice number and date of shipment must be established by the Buyer.

Buyer shall exercise diligence in inspection of sheets as received from Delta so as to mitigate repair or replacement. Delta extends this warranty solely to the original owner of and structure where the material is stalled. This warranty is not transferable and non-assignable. Delta reserves the right to terminate this warranty at any time (except as to orders already accepted) upon the giving of written notice thereof.

DELTA CONSOLIDATED, LLC MAKES NO GUARANTEES, EITHER EXPRESSED OR IMPLIED BEYOND THE FACE HEREOF, INCLUDING, WITHOUT LIMITATION, WARRANTIES, OF FITNESS AND MERCHANTABILITY, AND SHALL HAVE NO OTHER LIABILITY WITH RESPECT THERETO.

THIS WARRANTY HAS BEEN ISSUED TO:



205 Paillet Drive
Harvey, LA 70058
Ph: 504-368-5433
Fax: 504-368-5436

DATE:

SELECT 40 YEAR LIMITED WARRANTY

LIMITED WARRANTY AND LIMITATION OF LIABILITY FOR DELTA CONSOLIDATED, LLC (DC) PANEL-LOC, DELTA RIB, PBR, HORIZON-LOC, M-DELTA-LOC AND DELTA SEAM PLUS STEEL ROOFING AND SIDING PANELS THIS WARRANTY COVERS SELECT MATERIAL ONLY. PRIME AND THRIFTY MATERIAL ARE COVERED BY SEPARATE WARRANTIES.

DC is pleased to present you with our 40-year Select limited warranty.

For forty (40) years from the date of installation, the color coated finish WILL NOT crack, check or peel (lose adhesion). This does not include minute fracturing, which may occur in proper fabrication of the building parts. *Failure due to substrate corrosion is excluded.*

SIDEWALL PANELS (for thirty (30) years from installation or thirty and one half (30-1/2) years from coating application)

- a) WILL NOT chalk in excess of ASTM-D-4214-98 method A D659 number nine (9) rating.
- b) WILL NOT change color more than five (5.0) Hunter ΔE units as determined by ASTM method D-2244-02.

Color change shall be measured on an exposed painted surface that has been cleaned of surface soils and chalk, and the corresponding values measured on the original or unexposed painted surface. It is understood that fading or color changes may not be uniform if the surfaces are not equally exposed to the sun and elements.

ROOFING PANELS (for thirty (30) years from installation or thirty and one half (30-1/2) years from coating application)

- a) WILL NOT chalk in excess of ASTM D-4214-98 method A D659 number eight (8) rating.
- b) WILL NOT change color more than six (6.0) Hunter ΔE units as determined by ASTM method D-2244-02. Color change shall be measured on an exposed painted surface that has been cleaned of surface soils and chalk, and the corresponding values measured on the original or unexposed painted surface. It is understood that fading or color changes may not be uniform if the surfaces are not equally exposed to the sun and elements.

In case of a complaint, you will provide access to us and assist us as necessary in determining the exact cause of the failure. ASTM and NCCA testing procedures will be used, if our Select coating fail to comply with our limited warranty, we will pay for the labor and material reasonably necessary to repaint or replace; at our option, the building part showing the failure. In order for the warranty to be effective, however, you must notify us in writing of the failure within thirty (30) days of the discovery of such problem and provide any documentation we may require. If we repaint, we will use normal painting practices using the same paint system or other suitable alternatives. This warranty also applies to the part we repaint, repair, or replace, but only for the unexpired portion of the warranty period applicable to the original part.

Our LIMITED WARRANTY DOES NOT APPLY to circumstances which we do not control, including:

- Acts of God, falling objects, explosions, fire or other such similar or dissimilar occurrences beyond Delta's control;
- Unusual harmful fumes, foreign substances in the atmosphere, standing water, or salt spray;
- Improper treatment of or defects in the metal or in the fabrication;
- Stored or installed in a way that allows for poor air circulation;
- Stored or installed in a way that allows for contact with animals or animal waste
- Mishandled Products, e.g., ANY PRODUCT THAT HAS BEEN ABUSED, ALTERED, MODIFIED, USED IN A MANNER NOT ORIGINALLY INTENDED, OR STORED CONTRARY TO OUR INSTRUCTIONS. Including
- a) damage to the product occasioned by condensation attributable to improper packaging, handling, shipping, processing and /or installation;
- b) damage due to failure of the substrate.

This warranty will apply only to metal which is coated with Fluoropon and used on property located within the continental United States, Alaska, and Canada.

Some colors may not meet our high standards. The warranty applies only to colors that are on our approved color list. Metallics are not color measurable and are not applicable to section 1b.

For our warranty to apply, you must maintain certain record necessary to identify the Select panels involved in a complaint. You need to make them available to us for inspection and copying.

This is our only warranty concerning the Select products color coated finish. We have no other obligations concerning them. Please read and understand the following:

Except for this warranty, we make NO WARRANTY OR GUARANTEE, EXPRESS OR IMPLIED, WITH RESPECT TO OUR SELECT PRODUCTS COLOR COATED FINISH. IMPLIED WARRANTIES OR FITNESS AND MERCHANTABILITY ARE EXCLUDED. Further, we have no other liability with respect to our Select products color coated finish, whether based on warranty, negligence or any other legal theory. For example, we have no liability for consequential damages.

That is our complete warranty. It sets out all of our obligations regarding our Select product coil coatings. Its is only for your benefit and is not assignable. Such things as your purchase order forms or our Acceptance forms cannot change it. But it can be changed if DELTA agrees in writing.



205 Pallet Drive
Harvey, LA 70058
Ph: 504-368-5433
Fax: 504-368-5436

THIS WARRANTY HAS BEEN ISSUED TO:

DATE:

PRIME 40 YEAR LIMITED WARRANTY

FOR DELTA MANUFACTURING (DELTA) PANEL-LOC, DELTA RIB, PBR HORIZON-LOC, M-DELTA LOC, AND DELTA SEAM PLUS STEEL ROOFING AND SIDING PANELS. THIS WARRANTY COVERS PRIME MATERIAL ONLY. THIRTY MATERIAL IS COVERED BY A SEPARATE WARRANTY.

DC, warrants that the color-coated finish applied to its steel roofing and siding panels will not, within a period of forty years after installation or forty years and one month after the date of shipment (whichever comes first), crack, check, peel or lose adhesion. This does NOT include minute fracturing, which may occur in proper fabrication of the building parts. Failure due to substrate corrosion is excluded.

DC also warrants that the color-coated finish applied to its steel roofing and siding panels will not, within a period of thirty years after installation or a period of thirty years and one month after the date of shipment (whichever comes first), chalk or lose color according to the following grids. Additionally, chalk ratings are measured in accordance with the standard procedures specified in ASTM-D-4214-98 method D659. Color (fade) ratings are measured in accordance with the standard procedures specified in ASTM-D-2244-02. Color change shall be measured on an exposed painted surface that has been cleaned of surface soils and chalk, and the corresponding values measured on the original or unexposed painted surface. It is understood that fading or color changes may not be uniform if the surfaces are not equally exposed to the sun and elements.

1)DISCLAIMER OF WARRANTY. THE EXPRESS WARRANTY STATED HEREIN IS THE EXCLUSIVE WARRANTY APPLICABLE TO DC PANEL-LOC, DELTA RIB, PBR HORIZON-LOC, M-DELTA-LOC, AND DELTA SEAM PLUS PRIME PAINTED MATERIAL ONLY, ROOFING AND SIDING PANELS. DC MAKES NO WARRANTIES OR GUARANTEES, EITHER EXPRESSED OR IMPLIED, BEYOND THE FACE HEREOF INCLUDING, WITHOUT LIMITATION, WARRANTIES OF MERCHANTABILITY AND FITNESS FOR A PARTICULAR PURPOSE. DELTA SHALL HAVE NO OTHER LIABILITY WITH RESPECT THERETO. This warranty will apply to those panels refreshed or replaced but only for the period of time left on the original warranty. No employee or representative of DELTA is original warranty. No employee or representative of DELTA of authorized to change this limited warranty in any way or grant any other warranty regarding the product.

2) LIMITATION OF LIABILITY. THE EXCLUSIVE REMEDY FOR ANY AND ALL CLAIMS ARISING FROM THIS LIMITED WARRANTY SHALL BE LIMITED TO DELTA REFINISHING OR REPLACING DEFECTIVE PANELS OR REFUNDING THE PURCHASE PRICE OF SUCH PANELS AS DELTA SHALL ELECT. DELTA SHALL NOT BE LIABLE FOR ANY LOSSES, DAMAGES, OR EXPENSES, WHETHER DIRECT, INCIDENTAL, OR CONSEQUENTIAL DAMAGES, IF OUR DELTAGUARD SILICONIZED POLYESTER COATINGS FAIL TO COMPLY WITH OUR LIMITED WARRANTY, WE WILL PAY FOR THE LABOR AND THE MATERIALS REASONABLY NECESSARY TO REPAIR, REPAIR OR REPLACE, AT OUR OPTION, THE BUILDING PART SHOWING THE FAILURE. DELTA'S TOTAL LIABILITY IS EXPRESSLY LIMITED TO THE PURCHASE PRICE OF THE DELTA STEEL ROOFING AND SIDING PANELS.

3) Claims under this warranty must be made in writing to DELTA at the address set forth below within 30 days after the discovery of the defect. The notice to Delta shall include adequate identification of the material involved, nature of the claimed defect, date of the installation, date of shipment and order number. Failure of the claimant to provide such information in the time provided shall be deemed as a waiver of the claimant's rights herein. DELTA shall have an additional 30 days to inspect the DELTA steel roofing and siding panels before any further action shall be taken.

4) DELTA does not warrant or guarantee the interior or reversed side finish or prepainted materials used for interior application.

5) DELTA does not warrant or guarantee claims arising from damage to panels due to exposure to salt and salt water, water spray, corrosive or harmful chemicals (whether solids, liquids or gases), airborne contaminants, hail or other agents of a similar nature.

6) DELTA does not warrant or guarantee claims arising from the following:

- a) Damage or defects caused by acts of God, falling objects, external forces, explosion, fire, riots, civil commotion, acts of war, excessive radiation, or other similar or dissimilar occurrences beyond DELTA'S control.
 - b) Minor hairline cracking of the paint finish.
 - c) Defects or damages to the painted steel roofing and siding panels caused by handling, shipping, transit, processing, storage or installation; damage due to failure of the substrate.
 - d) Damage caused by moisture or other contamination prior to installation.
 - e) Steel shavings or minute iron particles from sawing sparks that come in contact with the painted surface.
 - f) Non-vertical panels that don't have an adequate degree of pitch so as not to allow any free standing or accumulation of standing water.
 - g) Stored or installed in a way that allows from contact with animal or animal waste.
 - h) Deterioration to the panels caused directly or indirectly by panel contact with fasteners. The selection of suitable fasteners rests solely with the buyer.
 - i) Weather uniformity under non-uniform conditions.
 - j) Unusual harmful fumes, chemically aggressive environment, foreign substances in the atmosphere, standing water or direct salt spray.
 - k) Damage due to green, wet or treated lumber.
- 7) The warranty applies to panels installed in the continental United States, Alaska, and Canada.
- 8) DELTA extends this warranty solely to the buyer. This warranty is not transferable and non-assignable. Further, it is applicable only to the original owner of any structure where the material is installed.



205 Pallet Drive
Harvey, LA 70058
Ph: 504-368-5433
Fax: 504-368-5436

THIS WARRANTY HAS BEEN ISSUED TO:

DATE:

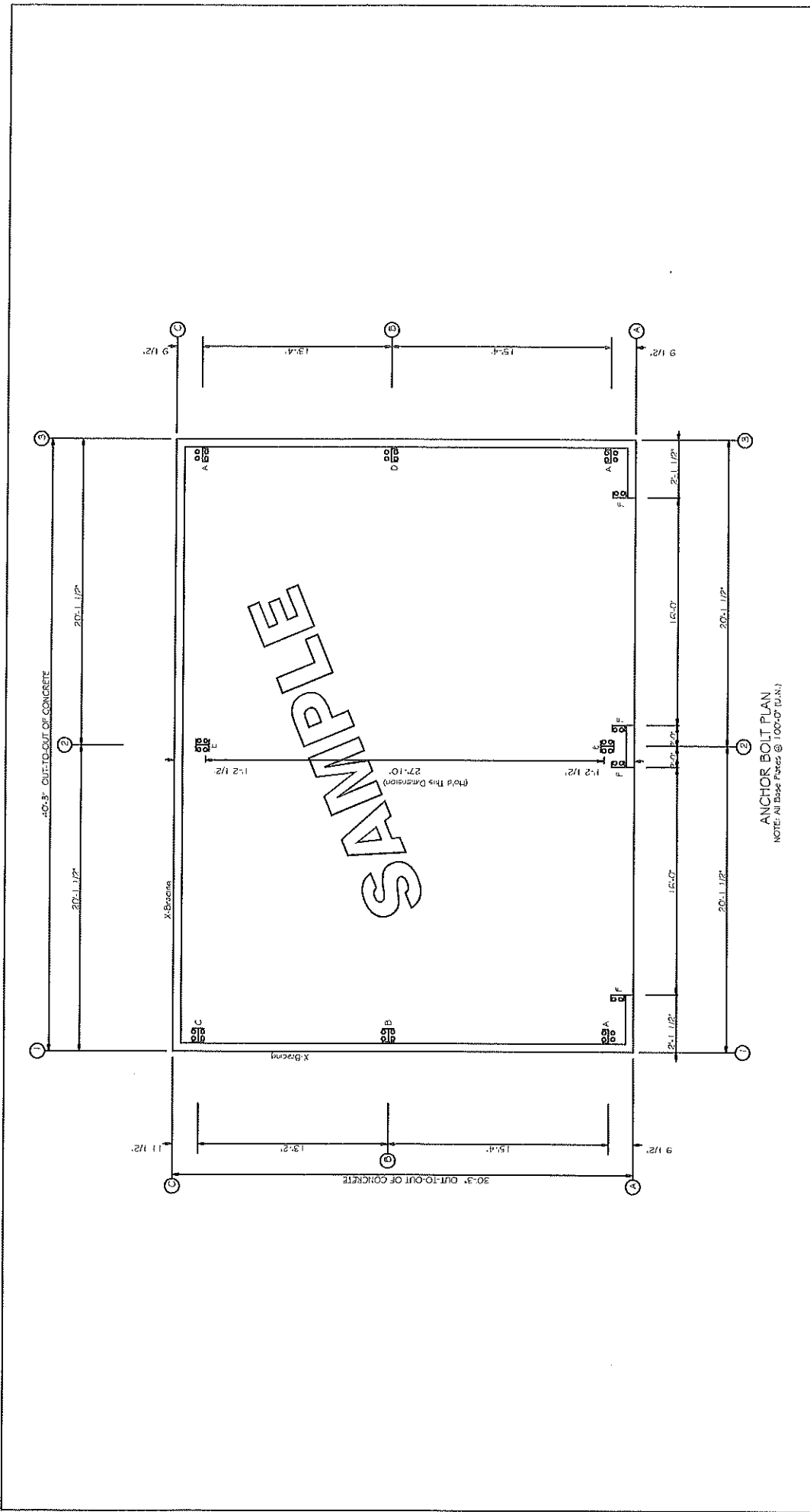

DELTA Consolidated, LLC			
PROJECT	ANCHOR BOLT PLAN		
ID	DESIGN	DRAFT	CHECK
PROJECT ADDRESS	DATE: 8/21/09	SHEET	F1

SAMPLE

NOTES FOR REACTIONS

Building reactions are based on the following building data:

- Roof Height (ft) = 30.0
- Roof Slope (rise/run) = 12.0/13.0
- Wind Speed (mph) = 30.0
- Exposure = C
- Importance Wind = 1.00
- Importance Seismic = 1.00
- Seismic Design Category = B
- Seismic Coeff (for S_s) = 0.05

ANCHOR BOLT SUMMARY

Orts	Loc	Dia (in)	Type
⊖	DJ	5/8"	
⊖	EW	3/4"	
⊖	RF	3/4"	

BRACING REACTIONS, PANEL SHEAR

Loc	Line	Wind	Horz	Vert	Panel Shear (lb/ft)
EW	1	1.7	1.7	0.0	0.0
SW	3	4.4	2.3	0.1	0.0
EW	4	2.1	4.4	2.3	0.1
SW	C	2.1	4.4	2.3	0.1

Main Frame REACTIONS (k)

DL + CL + LL

ENDWALL COLUMN REACTIONS(k)

MAXIMUM VERTICAL DL+CL+LL = 4.5
 MAXIMUM VERTICAL DL+WL = 4.5
 MAXIMUM HORIZONTAL DL+LL = 2.8
 MAXIMUM HORIZONTAL DL+WL = 2.8

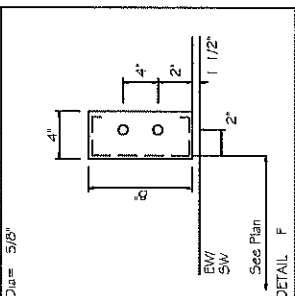
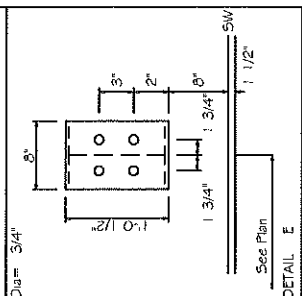
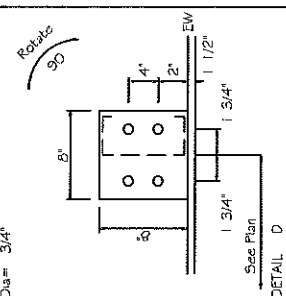

DELTA Consolidated, LLC	
PROJECT ID	ANCHOR BOLT DETAILS & REACTIONS
PROJECT ADDRESS	DESIGN: DRAFT: CHECK:
	DATE: 8/21/09 SHEET: F2

SPLICE PLATES & BOLTS							
Splice Mark	Qty	Top/ Bot/ Int	Type	Dia	Length	Plate Size Width	Thick
SP-1	4	4	O	A325	0.750	2.00	1/2"
SP-2	4	4	O	A325	0.750	1.75	3/8"

MARK	MEMBER SIZE TABLE (in)		OUTSIDE FLANGE W x T x LENGTH	INSIDE FLANGE W x T x LENGTH
	WEB DEPTH START/END	WEB PLATE THICK. LENGTH		
RF1-1	12.0/19.0	0.134 142.0	5 x 3/16" x 157.2	5 x 3/16" x 119.2
RF1-2	18.7/10.0	0.134 150.8	6 x 3/16" x 28.0	5 x 3/16" x 156.1
RF1-3	19.0/12.0	0.134 142.0	6 x 3/16" x 28.0	5 x 3/16" x 119.2

▽ FLANGE BRACES: Both Sides(U.N.)
 FBWA(1)
 A - L2X2X1/8

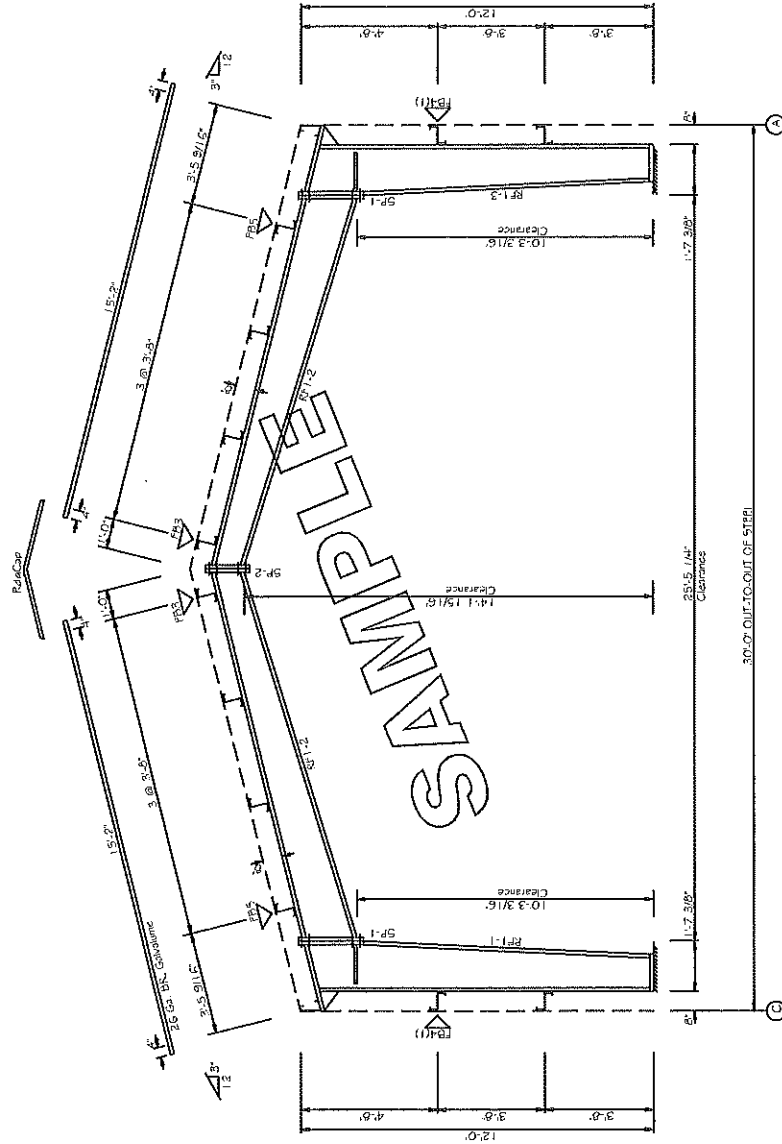

BUILDING CROSS SECTION
 FOR FRAME LINE 2

DELTA Consolidated, LLC	
PROJECT	RIGID FRAME ELEVATION
ID	DESIGN
PROJECT ADDRESS	DATE: 8/21/09
	SHEET E1

PROJECT	RIGID FRAME ELEVATION
ID	DESIGN
PROJECT ADDRESS	DATE: 8/21/09
	SHEET E1

MEMBER TABLE		
ROOF PLAN		LENGTH
MARK	PART	
P-1	6X25Z16	21'-1/2"
P-2	6X25Z16	21'-1/2"
E-1	6E514	19'-1/2"
E-2	6E514	19'-1/2"
E-3	6E514	19'-1/2"
E-4	6E514	19'-1/2"
CB-5	3/8 Cap	24'-2"
CB-6	3/8 Cap	23'-10"
CB-7	1/4 Cap	23'-11"
CB-8	1/4 Cap	24'-3"

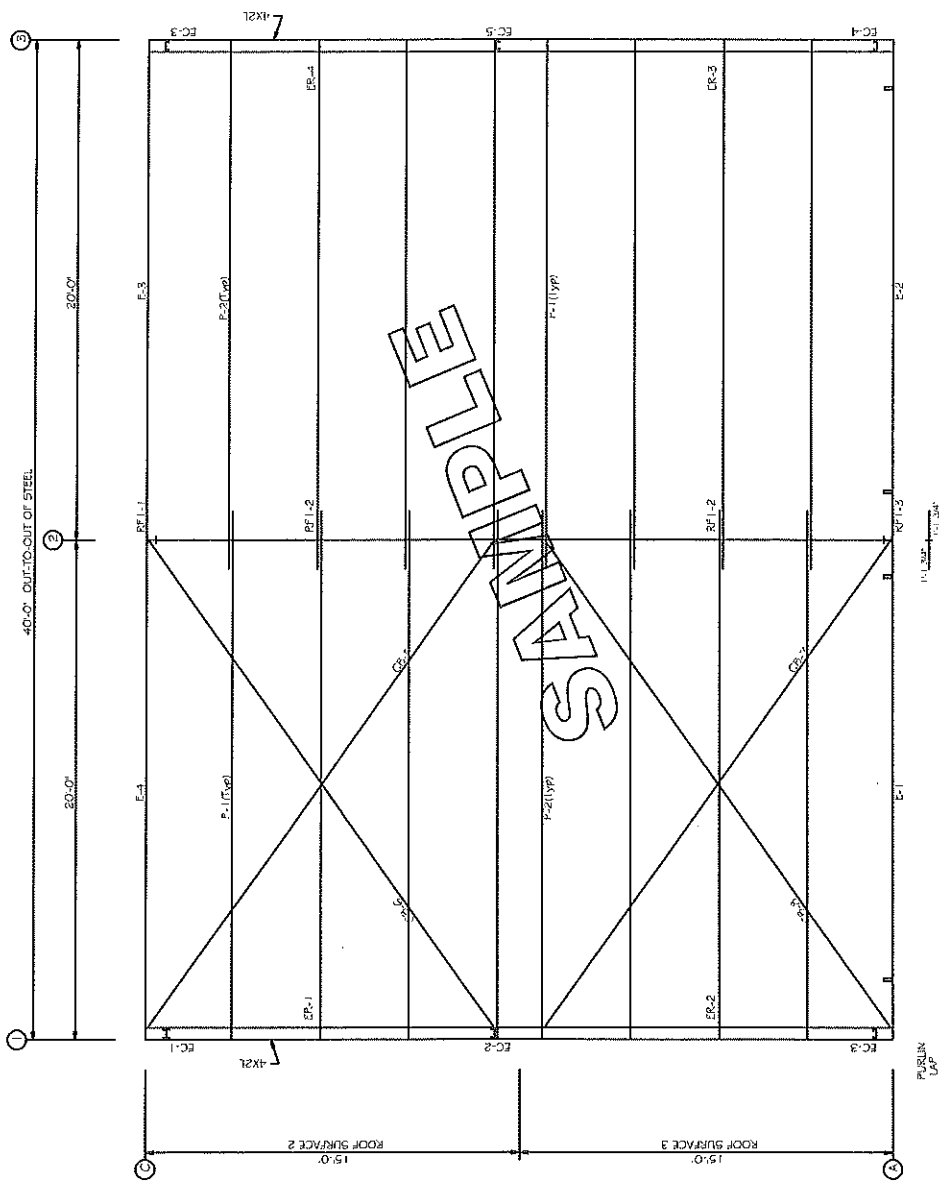

ROOF FRAMING PLAN

DELTA Consolidated, LLC			
PROJECT	ROOF FRAMING	DESIGN:	CHECK:
ID		DATE: 8/21/09	SHEET E2
PROJECT ADDRESS			

BOLT TABLE

FRAME LINE	LOCATION	QUAN	TYPE	DIA	LENGTH
ER-1/ER-2		4	A325	5/8"	3/4"
EC-1/ER-1		4	A325	5/8"	1/2"
EC-2/ER-1		4	A325	5/8"	1/2"
EC-3/ER-2		2	A325	5/8"	1/2"

MEMBER TABLE

MARKS	PART	LENGTH
FC-1	W8x13	11'-4" 3/4"
FC-2	W8x13	14'-9" 1/4"
FC-3	8x35C16	11'-4" 1/16"
ER-1	8x35C12	5'-5" 9/16"
ER-2	8x35C14	5'-5" 9/16"
G-1	8x25Z16	2'-6" 1/2"
G-2	8x25Z16	4'-3" 1/2"
G-3	8x25Z14	4'-3" 1/2"
CB-1	1/4 Cap	9'-8"
CB-2	1/4 Cap	7'-5"

FLANGE BRACE TABLE

FRAME LINE	MARK	LENGTH
1	FBI	2'-5" 3/16"

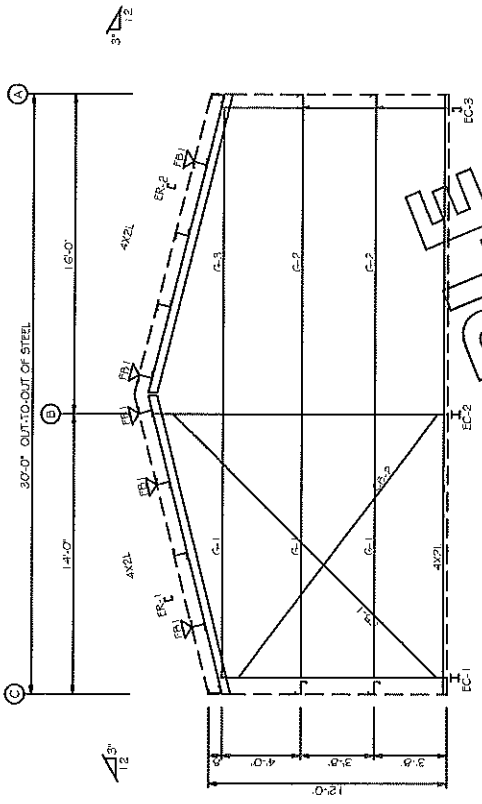

ENDWALL FRAMING: FRAME LINE 1

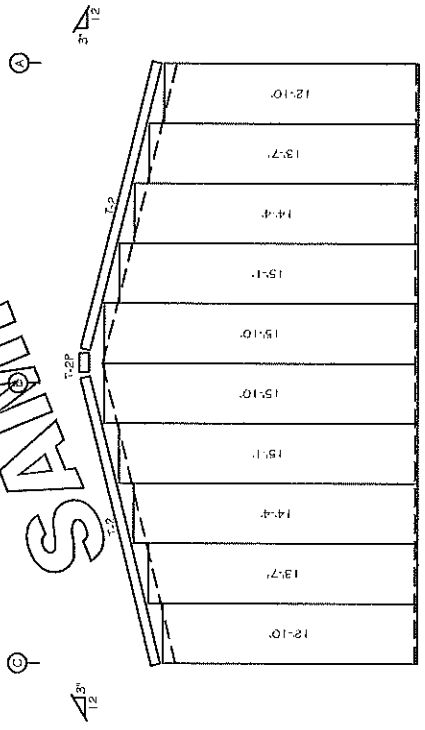

ENDWALL SHEETING & TRIM: FRAME LINE 1

PANELS: 26 G3, R - NEED COLOR

DELTA Consolidated, LLC			
PROJECT	ENDWALL FRAMING		
ID	DESIGN	DRAFT	CHECK
PROJECT ADDRESS	DATE: 8/21/09	SHEET	E3

BOLT TABLE

FRAME LINE	QUAN	TYPE	DIA	LENGTH
ER-3/ER-4	4	A325	5/8"	1 1/2"
Columns/Raf	2	A325	5/8"	1 1/2"

MEMBER TABLE

MARK	PART	LENGTH
EC-3	8X35C16	11'-4" 1/16"
EC-4	8X35C16	11'-4" 1/16"
EC-5	8X40C12	14'-8" 3/4"
ER-3	8X35C14	15'-5" 9/16"
ER-4	8X35C14	15'-5" 9/16"
G-4	8X25Z16	14'-8"
G-5	8X25Z16	14'-8"
G-6	8X25Z16	13'-0"

FLANGE BRACE TABLE

FRAME LINE	W/D MARK	LENGTH
FRAME LINE 3	1 1/2"	2'-5" 3/16"

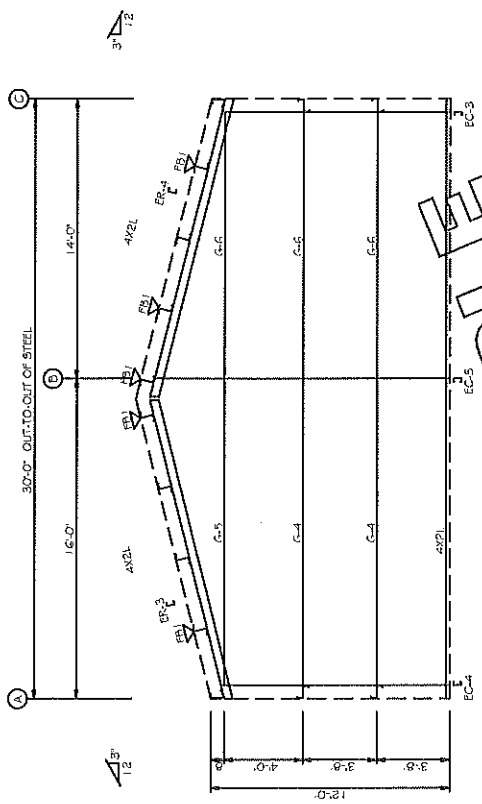

SAMPLE

ENDWALL FRAMING - FRAME LINE 3

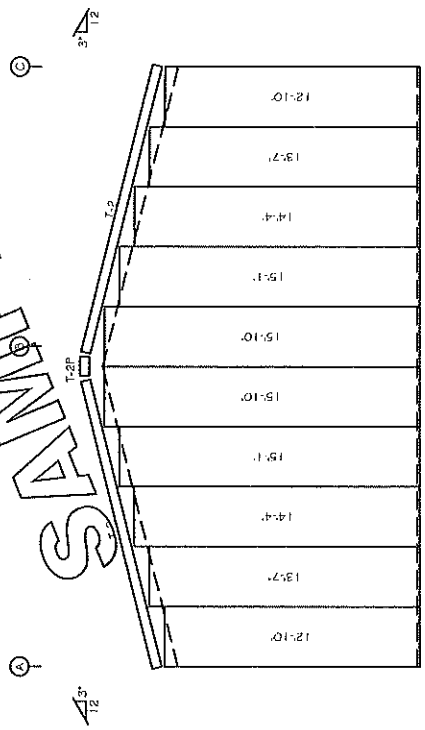

ENDWALL SHEETING & TRIM - FRAME LINE 3

PANELS: 26 Gs. R. - NEED COLOR

DELTA Consolidated, LLC

PROJECT	ENDWALL FRAMING		
ID	DESIGN	DRAFT	CHECK
PROJECT ADDRESS	DATE: 8/21/09	SHEET	E-4

MEMBER TABLE

MARK	PART	LENGTH
DJ-1	8X25C14	11'-6"
DJ-2	8X25C14	11'-6"
DH-1	8X25C14	16'-0"
E-1	8F514	9'-1 1/2"
E-2	8F514	9'-1 1/2"
G-7	8X25Z16	1'-9" 1/2"
G-8	8X25Z12	3'-6" 1/2"

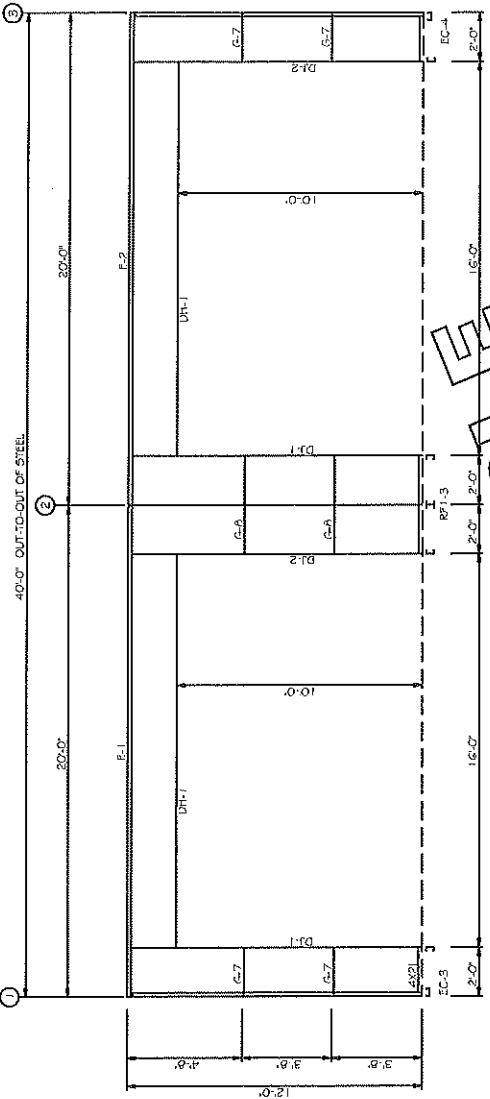

SIDEWALL FRAMING: FRAME LINE A

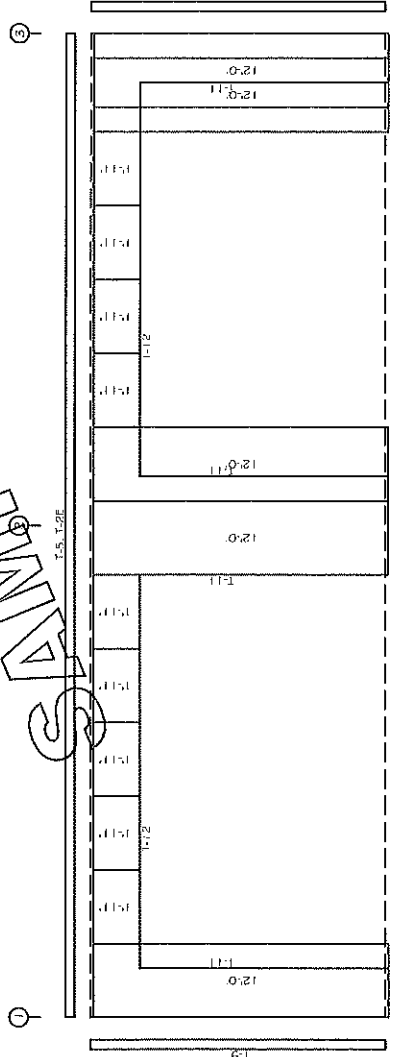

SIDEWALL SHEETING & TRIM: FRAME LINE A

DELTA Consolidated, LLC

PROJECT	SIDEWALL FRAMING		
ID	DESIGN:	DRAFT:	CHECK:
PROJECT ADDRESS	DATE: 8/21/09	SHEET	E5

MEMBER TABLE			
FRAME LINE C			
MARK	PART	LENGTH	
E-3	BE514	19'-1 1/2"	
E-4	BE514	19'-1 1/2"	
G-9	8X25Z16	22'-1 1/2"	
G-10	8X25Z16	22'-1 1/2"	
CB-3	3/8 Csb	22'-1"	
CB-4	3/8 Csb	22'-6"	

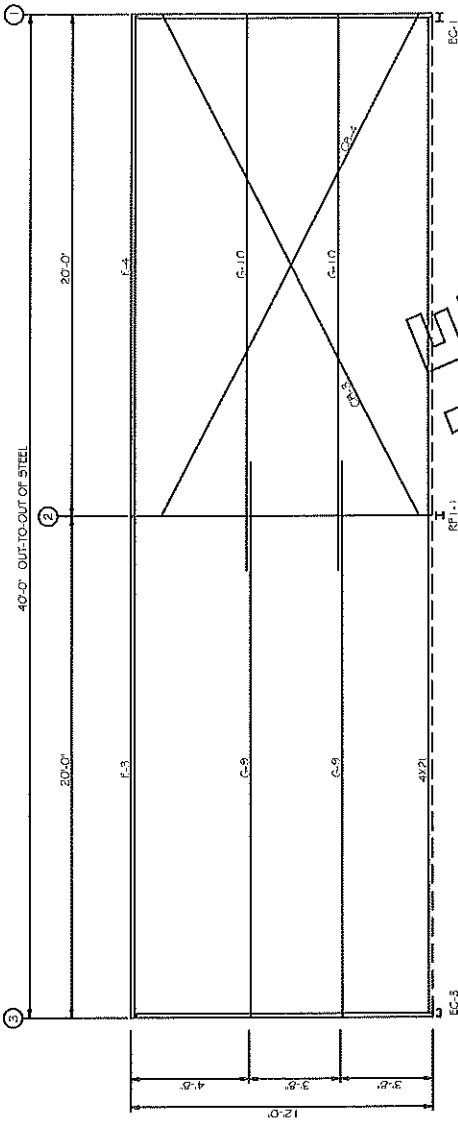

SAMPLE

SIDEWALL FRAMING: FRAME LINE C

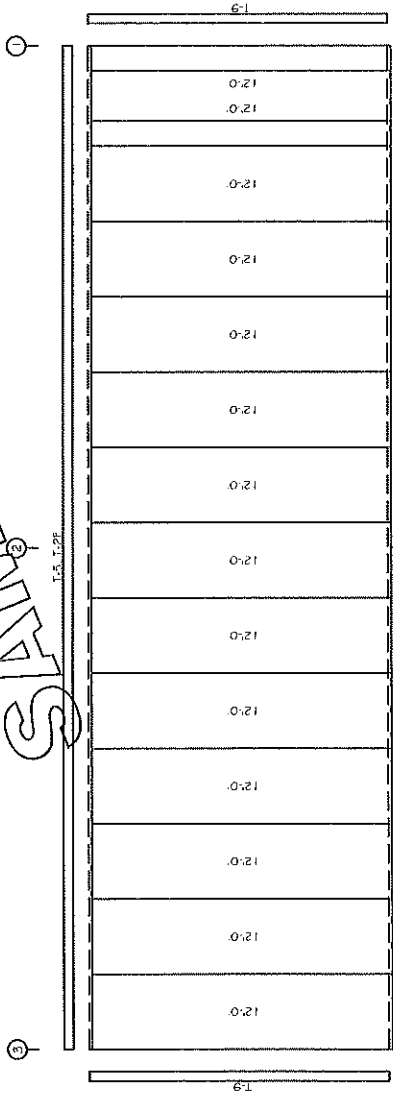

SIDEWALL SHEETING & TRIM: FRAME LINE C

PANELS: 26 Gb. R - NEEDED COLOR

DELTA Consolidated, LLC			
PROJECT	SIDEWALL FRAMING		
ID	DESIGN	DRAFT	CHECK
PROJECT ADDRESS	DATE: 8/21/09	SHEET	E6

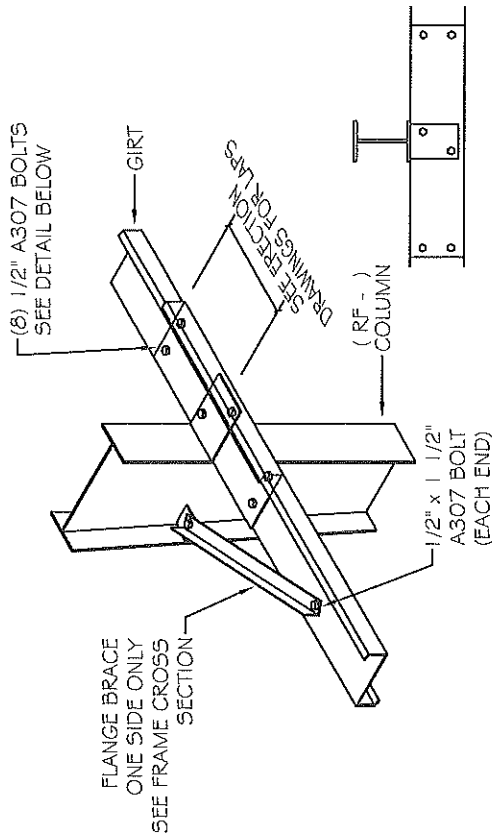

BYPASS GIRT LAP - FLANGE BRACE

FLUSH GIRT

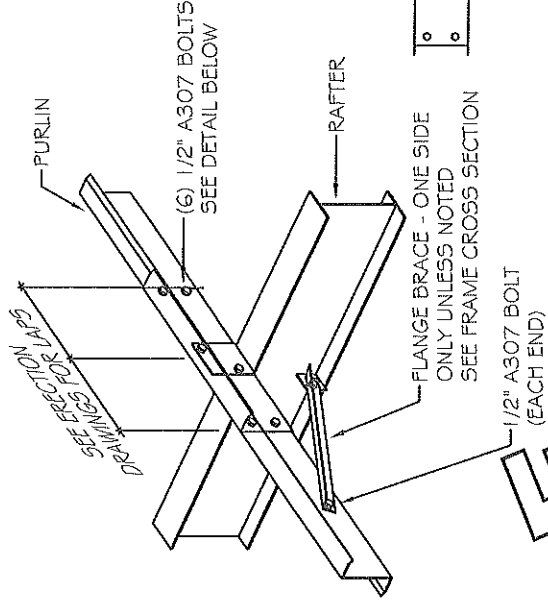

PURLIN LAP - FLANGE BRACE

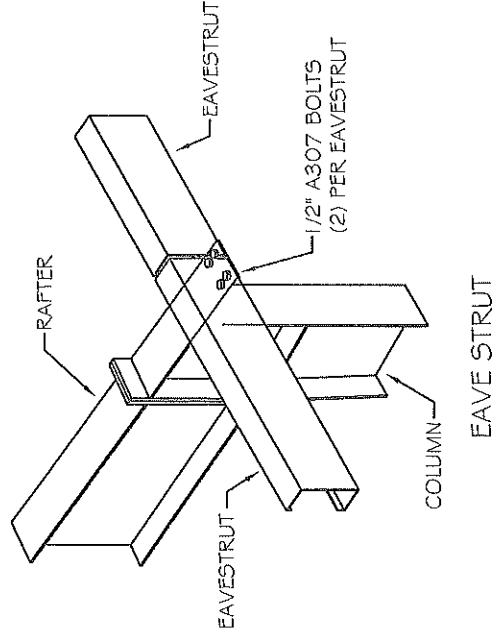

EAVE STRUT

DELTA
Consolidated, LLC

BUILDING DETAILS
Secondary Framing Connections
Purlin - Girt - Eavestrut
Flange Brace

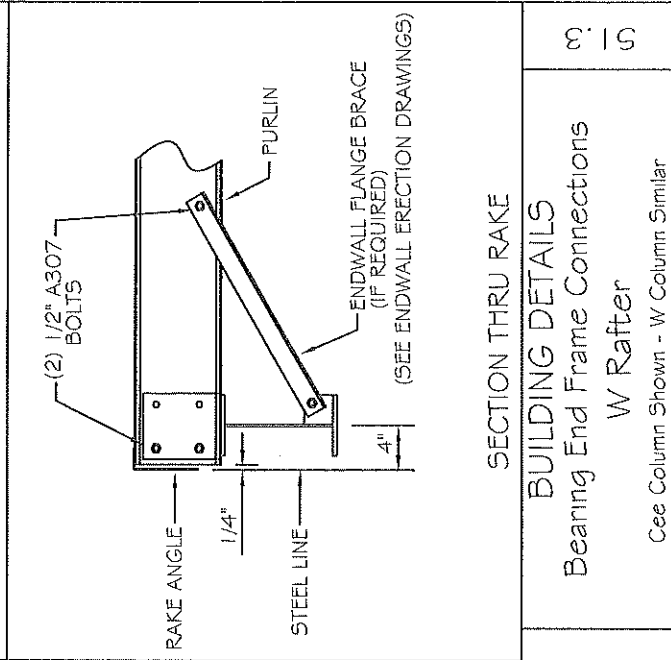
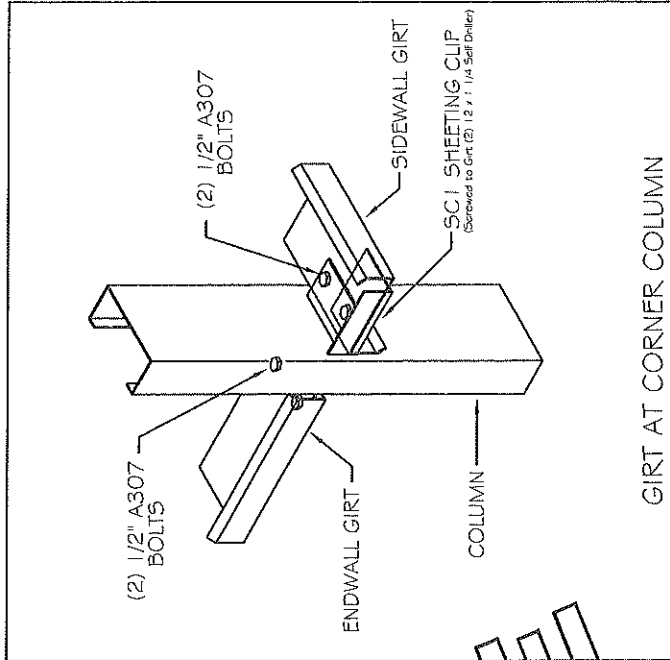
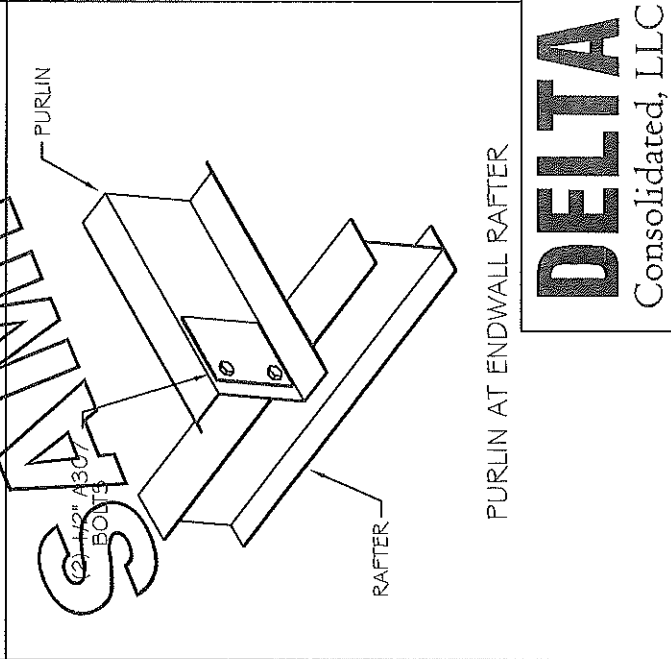
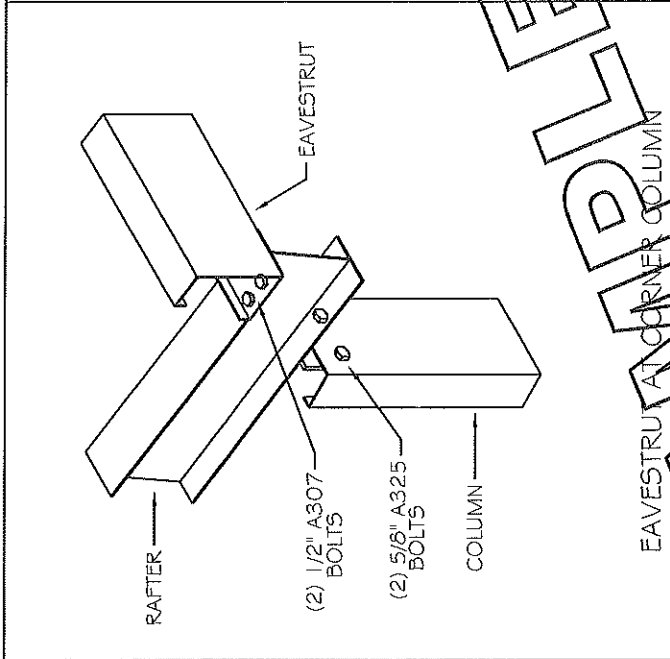
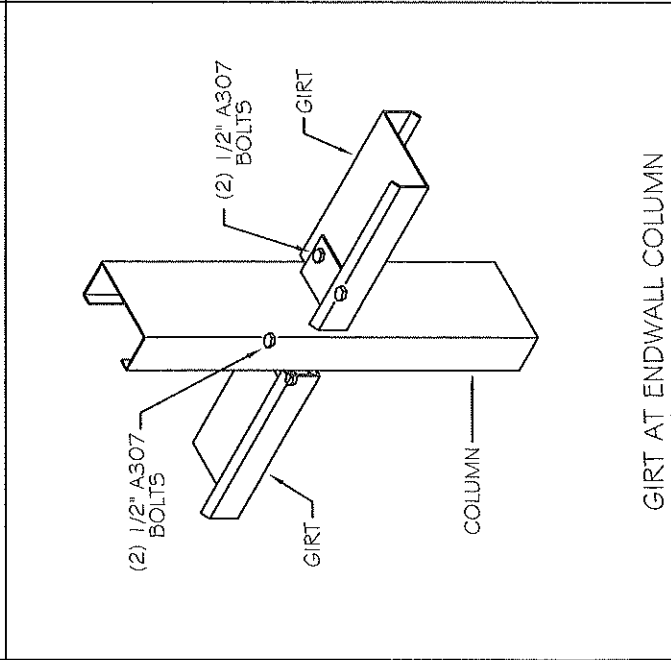
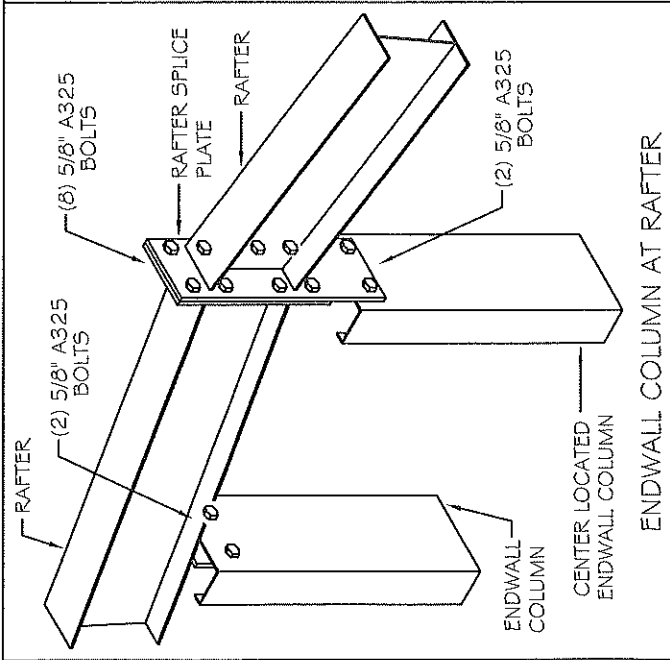

DELTA
Consolidated, LLC

SECTION THRU RAKE
BUILDING DETAILS
Bearing End Frame Connections
W Rafter
See Column Shown - W Column Similar

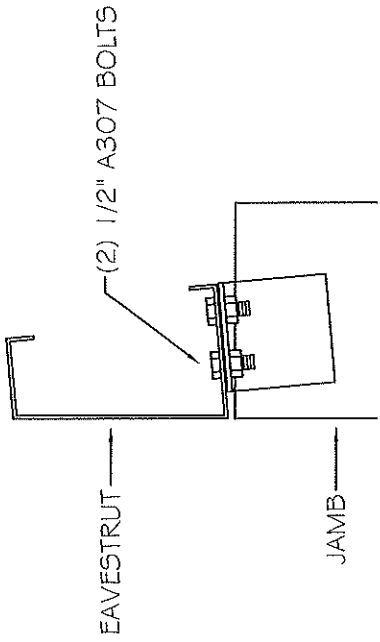

JAMB TO EAVE STRUT

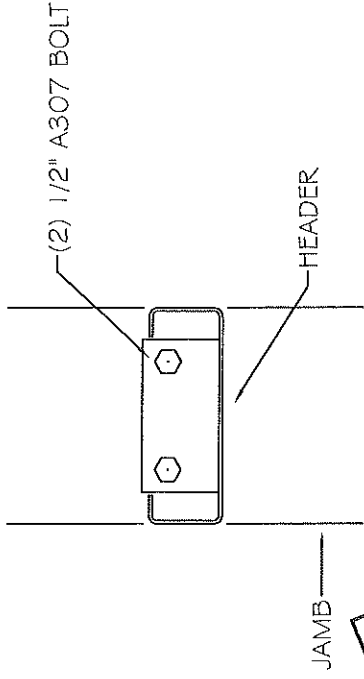

JAMB TO HEADER

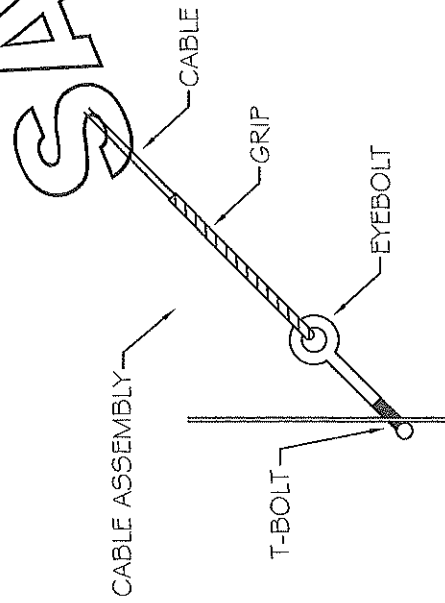

T-BOLT ASSEMBLY

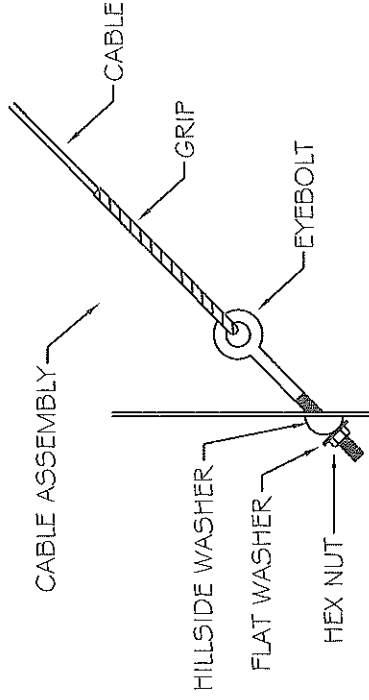

CABLE BRACE

DELTA
Consolidated, LLC

BUILDING DETAILS
Secondary Framing Connections
Framed Openings
Cable Brace

STITCH SCREW SPACING

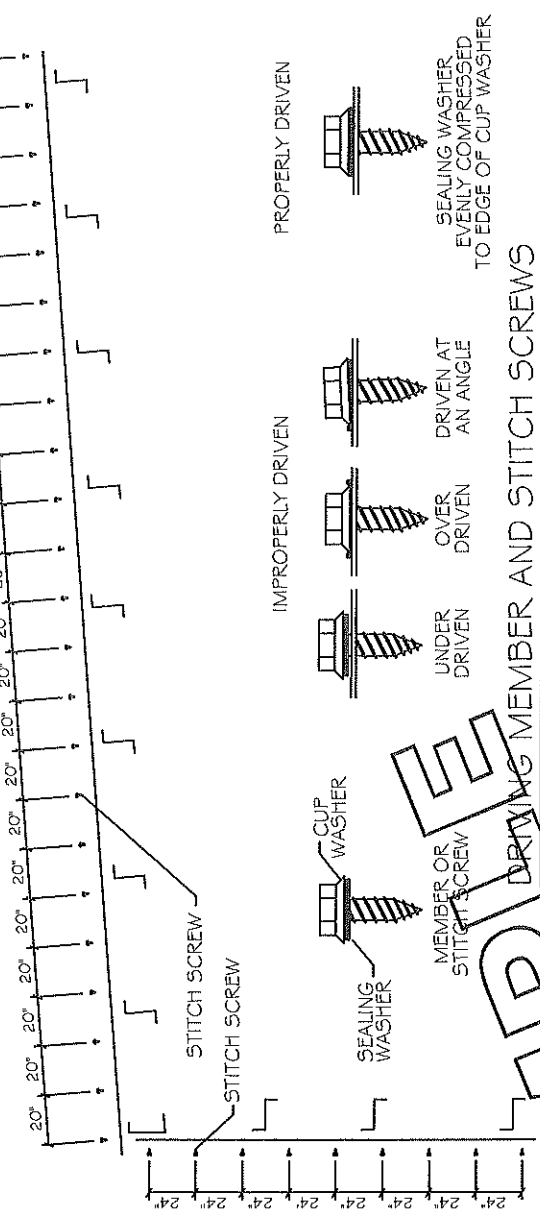

IMPROPERLY DRIVEN

PROPERLY DRIVEN

SEALING WASHER
EVENLY COMPRESSED
TO EDGE OF CUP WASHER

UNDER
DRIVEN

OVER
DRIVEN

DRIVEN AT
AN ANGLE

DRAWING MEMBER AND STITCH SCREWS

STANDARD MEMBER SCREW
(PANEL OR TRIM TO SECONDARY)
12 x 1 1/4" SELF DRILLER
WITH SEALING WASHER

STANDARD MEMBER SCREW
(PANEL SIDELAPS OR TRIM TO PANEL)
12 x 3/4" Pierce Point
LAP-TEK WITH SEALING WASHER

THE PANEL ACTS A SHEAR DIAPHRAGM TO RESIST FORCES
IMPARTED BY WIND AND SEISMIC LOADS.
MEMBER AND STITCH SCREWS MUST BE INSTALLED PRECISELY
AS DESCRIBED ON THIS DRAWING.
FAILURE TO PROPERLY INSTALL THESE FASTENERS WILL
JEOPARDIZE THE STRUCTURAL INTEGRITY OF THE BUILDING.

MEMBER SCREWS ATTACHING TRIM TO SECONDARY FRAMING
ARE GENERALLY SPACED AT 20" ON CENTER
STITCH SCREWS ATTACHING TRIM TO TRIM ARE GENERALLY
SPACED AT 20" ON CENTER AND TO PANEL AT MAJOR RIBS.
EXCEPTIONS TO THIS SPACING WILL BE SHOWN ON ERECTION
DETAIL DRAWINGS. (55, 56, 58 etc.)

BUILDING DETAILS
Screw Placement
Roof Panel - Wall Panel
Trim

DELTA
Consolidated, LLC

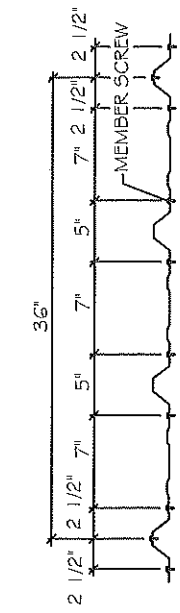

FASTENER SPACING AT PEAK PURLIN, EAVESTRUITS AND END LAPS

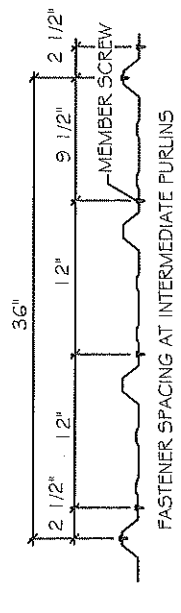

FASTENER SPACING AT INTERMEDIATE PURLINS

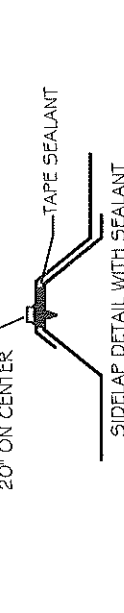

ROOF PANEL FASTENER SPACING

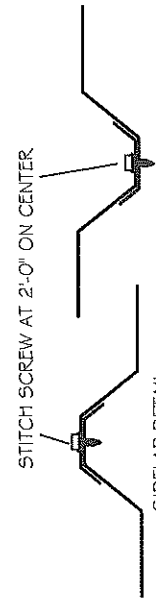
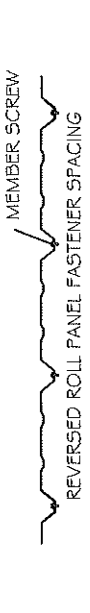
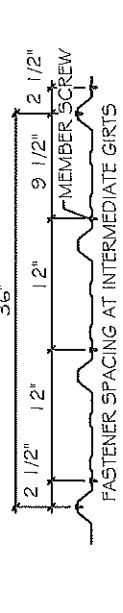
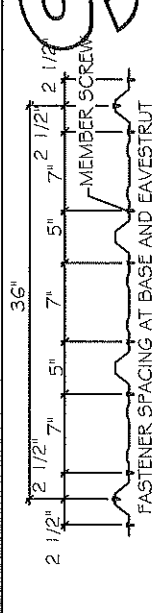

WALL PANEL FASTENER SPACING



ROOF SHEETING LAP

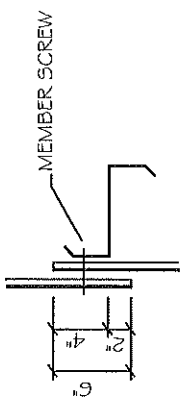

WALL SHEETING LAP

FASTENERS

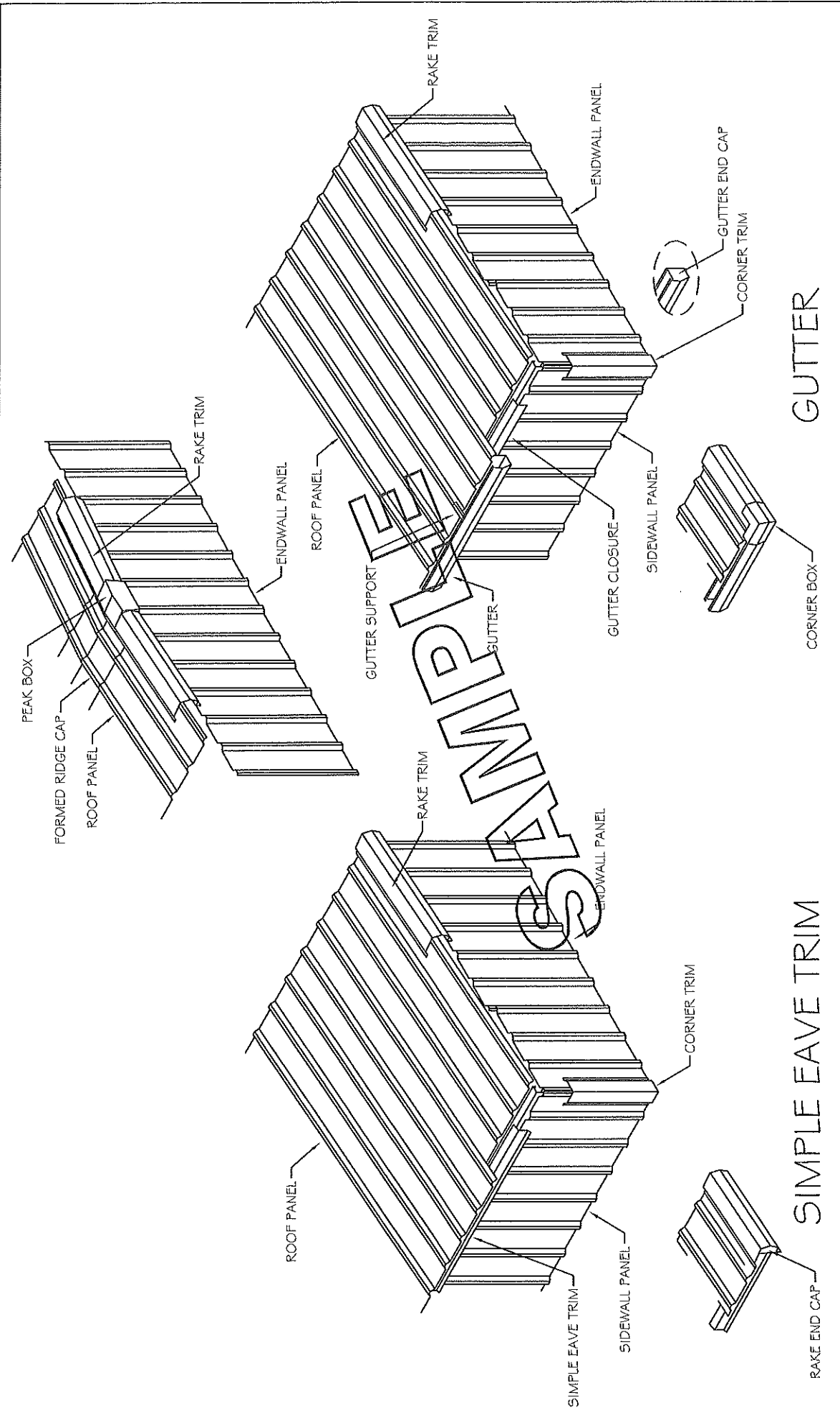

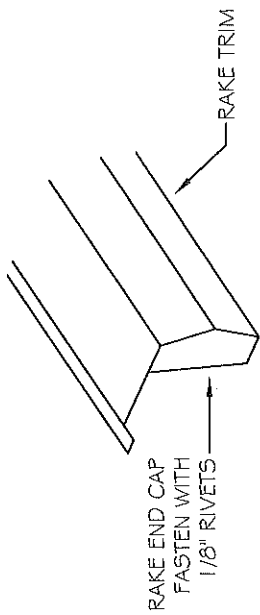

RAKE END CAP
FASTENED WITH
1/8" RIVETS

RAKE TRIM

INSIDE CLOSURE WITH
TAPE SEALANT
AT BOTTOM

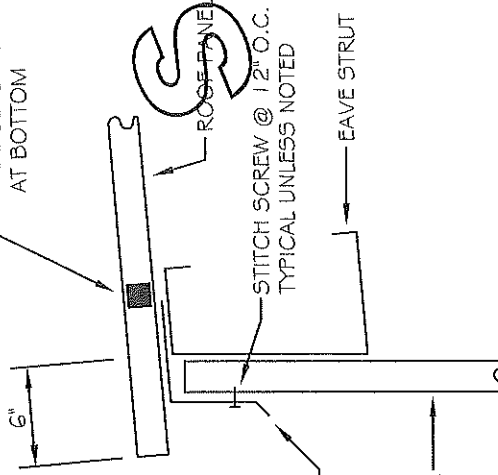

6"

ROOF PANEL

STITCH SCREW @ 12" O.C.
TYPICAL UNLESS NOTED

EAVE STRUT

SIDEWALL PANEL

SIMPLE EAVE TRIM

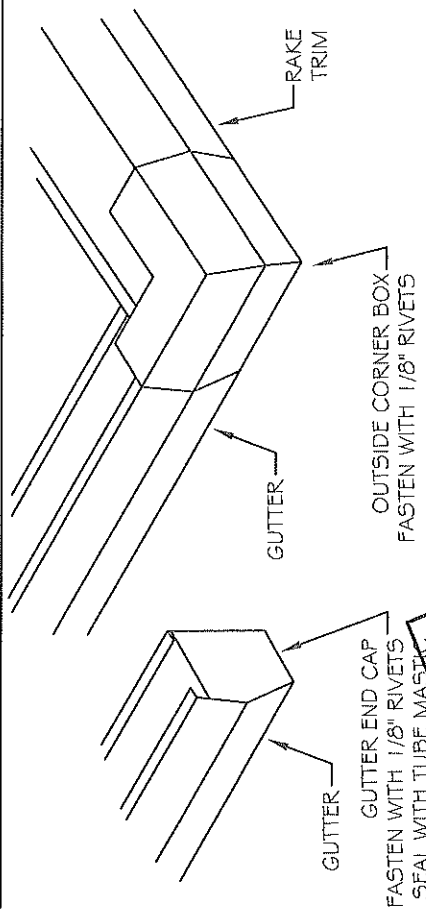

GUTTER
GUTTER END CAP
FASTENED WITH 1/8" RIVETS
SEAL WITH TUBE MASTIC

GUTTER

OUTSIDE CORNER BOX
FASTENED WITH 1/8" RIVETS

RAKE TRIM

GUTTER STRAP
@ 36" O.C. WITH
(3) STITCH SCREWS

INSIDE CLOSURE WITH
TAPE SEALANT
AT BOTTOM

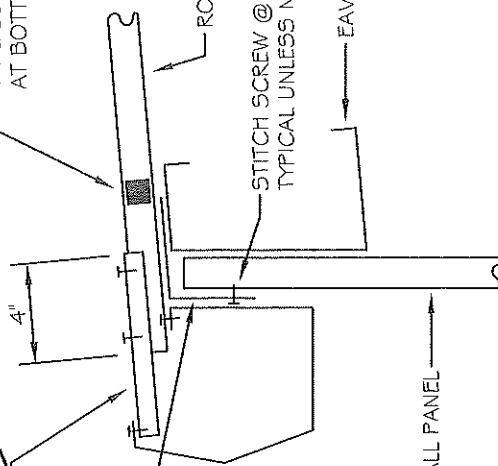

4"

GUTTER CLOSURE

GUTTER

STITCH SCREW @ 12" O.C.
TYPICAL UNLESS NOTED

EAVE STRUT

SIDEWALL PANEL

GUTTER

DELTA
Consolidated, LLC

BUILDING DETAILS
Trim Installation
Simple Eave Trim
Gutter

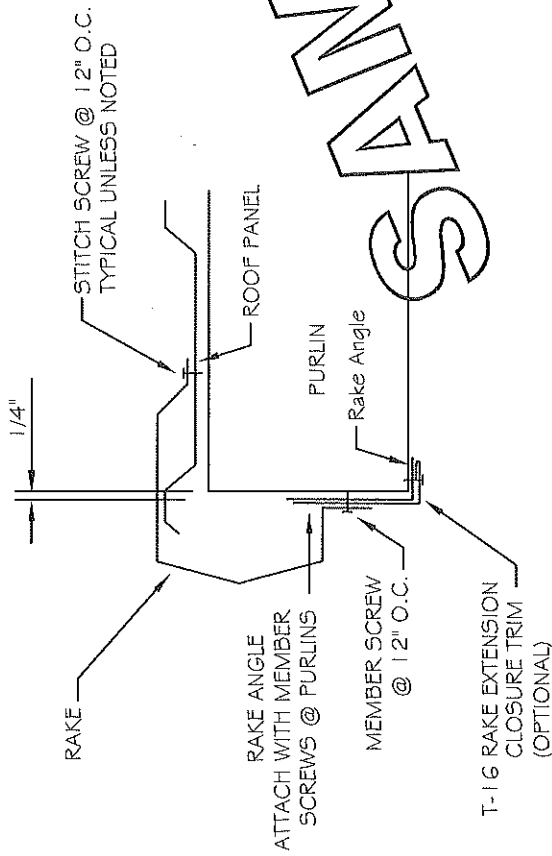

OPEN WALL RAKE TRIM

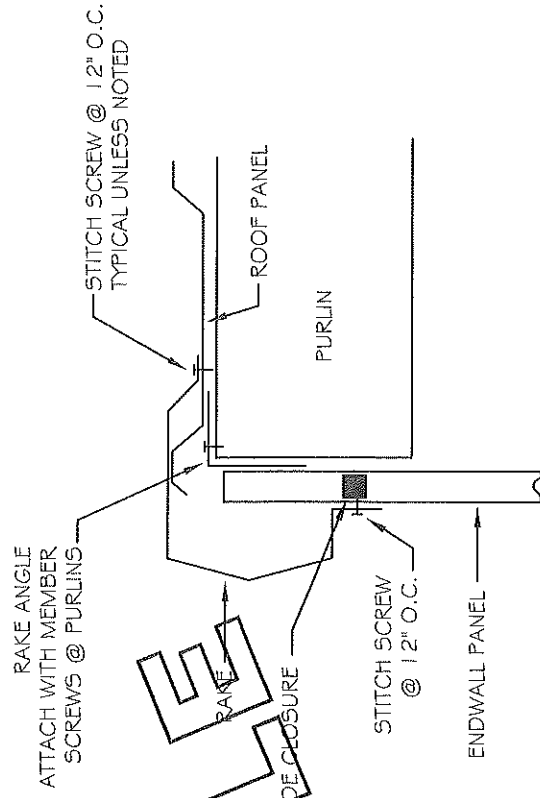

RAKE TRIM

DELTA
Consolidated, LLC

BUILDING DETAILS
Trim Installation
Rake Trim
Rake Trim at Open Endwall

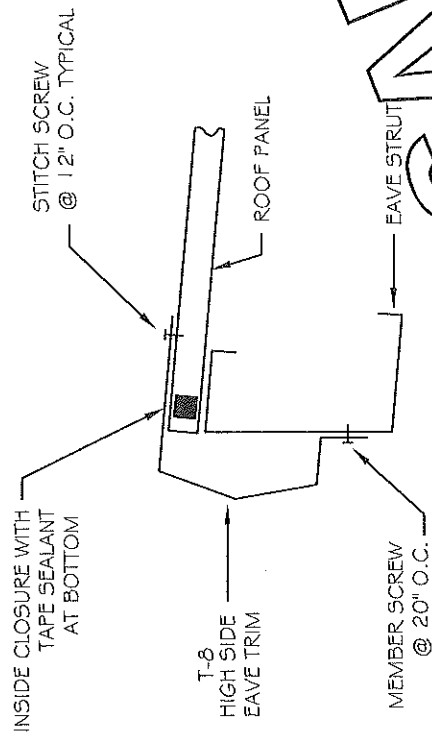

OPEN WALL HIGH SIDE EAVE

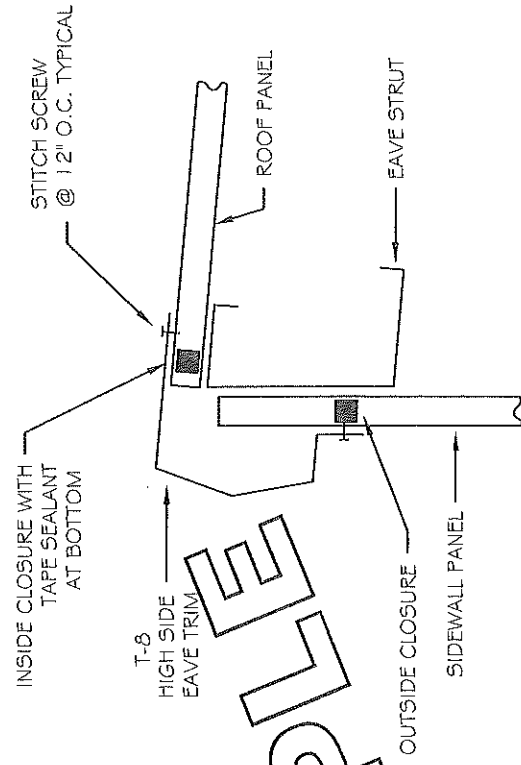

HIGH SIDE EAVE

DELTA
Consolidated, LLC

BUILDING DETAILS
Trim Installation
High Side Eave
High Side Eave at Open Wall

54.4

10/1/02

LOCATE DOWNSPOUT AT HIGH RIB.
CUT CROSS PATTERN IN BOTTOM OF GUTTER

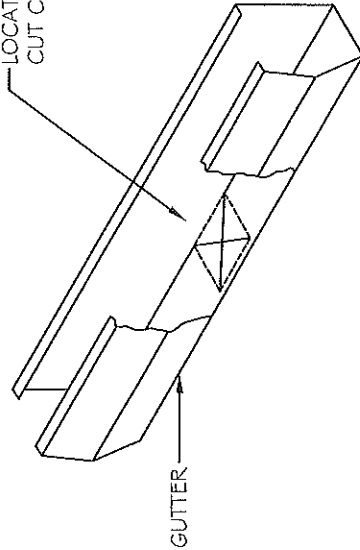

BEND TABS DOWN.
SLIP DOWNSPOUT OVER TABS.
USE 1/8" RIVETS TO SECURE
DOWNSPOUT TO GUTTER TABS.
SEAL WITH TUBE MASTIC.

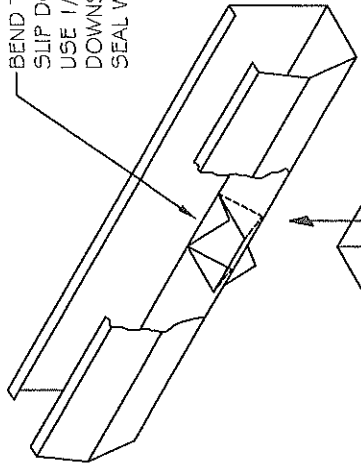

UPPER
DOWNSPOUT

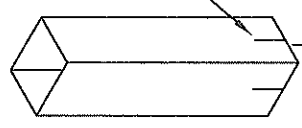

SLIT EACH SIDE OF
UPPER DOWNSPOUT
AND LAP 2" INSIDE OF
LOWER DOWNSPOUT.
SECURE WITH 1/8" RIVETS



LOWER
DOWNSPOUT

DOWNSPOUT SPLICE

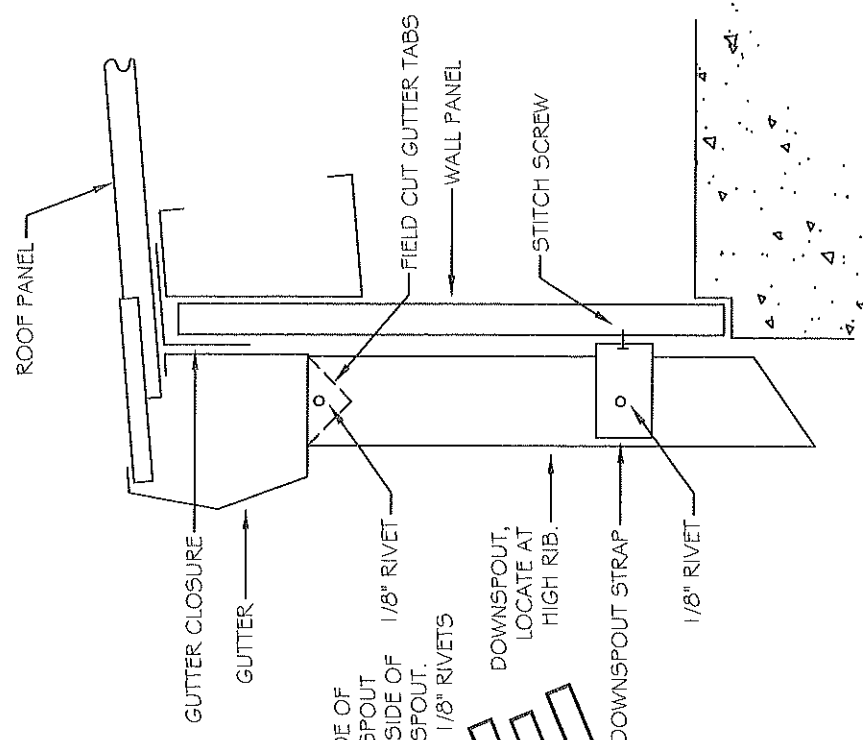

SECTION

SAMPLE

DOWNSPOUT

DELTA
Consolidated, LLC

BUILDING DETAILS
Trim Installation
Downspout

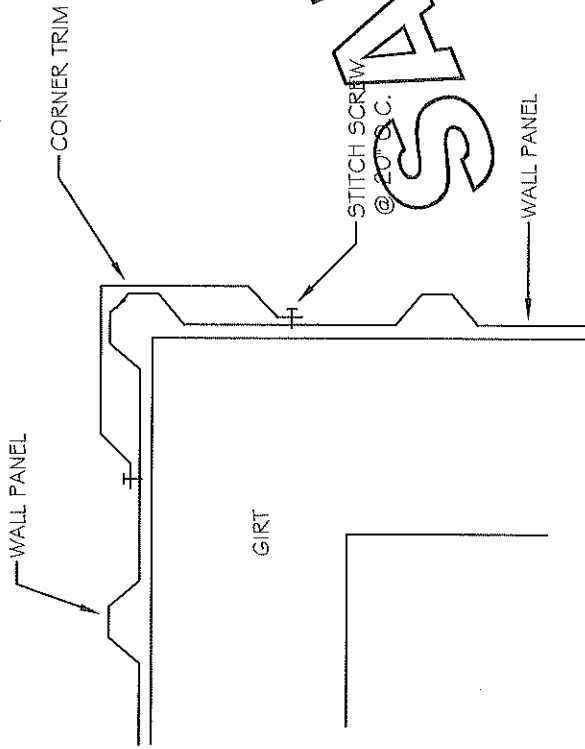

CORNER TRIM

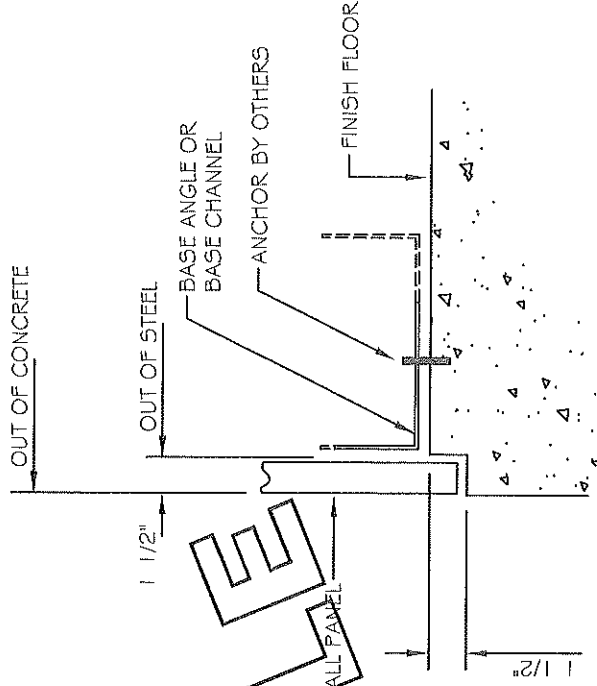

BASE DETAIL

DELTA
Consolidated, LLC

BUILDING DETAILS
Trim Installation

Corner
Base Angle - Base Channel