

DAMMON

ENGINEERING, INC.

Architects & Engineers

SHOP DRAWING and SAMPLE TRANSMITTAL

554 Old Spanish Trail
 Slidell, LA 70458
 985.649.5832
 www.dammonengineering.com
 info@dammonengineering.com

DATE: 6/19/2025

TO: Cheri Rush
 M Natal Contractor, Inc.
 P.O. Box 518
 Slidell, La

FROM: Chuck Dammon

SUBMITTAL No.: 085000.001.0

REFERENCE: **STP Fire District 1 Training Center**

DE Project: 2507

WE TRANSMIT:

enclosed under separate cover _____

FOR YOUR:

use record approval
 review and comment information drafting

THE FOLLOWING:

drawing(s) contracts specifications
 shop drawings samples change order(s)
 product information warranty substitution request

# COPIES	DESCRIPTION	ACTION
Electronic	Glass	A

ACTION CODES:

- A. Reviewed/No Exceptions
- B. Reviewed/Exceptions Noted
- C. Revise and Resubmit
- G. Rejected
- D. No Action Required
- E. For Signature and Return to this Office
- F. See Remarks Below

REMARKS:

All glass shall match Training Facility#1

COPIES TO: File

SUBMITTAL COVER SHEET

Arch. Project No: _____

MNC Project No: 830

To: Dammon Engineering, Inc.
554 Old Spanish Trail
Slidell, Louisiana 70458
info@dammonengineering.com

From: Cheri Rusich
M Natal Contractor, Inc.
P.O. Box 518
Slidell, LA 70459

Attn. David Dammon
Chuck Dammon

Sent Via E-Mail

General Contractor's Review:

M Natal Contractor, Inc.

<p>SUBMITTAL NO: <u>085000.001.0</u></p> <p>SPEC. SEC. NO: <u>085000</u></p> <p>VENDOR/SUB: <u>Dwaynes Glass and Mirror</u></p> <p>DESCRIPTION: <u>Architect Glass, Laminare Glass, Technical Bulletin Data</u></p>	<p>CONTRACTOR'S REVIEW:</p> <p>NO EXCEPTIONS TAKEN <input checked="" type="checkbox"/></p> <p>FURNISH AS CORRECTED <input type="checkbox"/></p> <p>REJECTED; RESUBMIT <input type="checkbox"/></p> <p>PARTIAL APPROVAL; SUBMIT ADD'L ITEM(S) <input type="checkbox"/></p>
---	--

Reviewing is for conformance with the design concept of the project and compliance with the information given in the Contract Documents. The Vendor/Subcontractor is responsible for dimensions to be confirmed and correlated at the site for information that pertains solely to the fabrication process or to the means, method, technician, sequences, and procedures of construction; and for coordination of the work with all trades.

BY Cheri Rusich DATE: 06/02/2025

Architect/Engineer Review:

OK to send to Chuck
 6-3-25 x ML

DAMMON ENGINEERING, INC

Date: 06-19-25 Project: Training Facility #2
 Reviewed: X
 Reviewed as noted: _____
 Revise and ReSubmit: _____
 Rejected: _____
 Other: _____

Correction or comments made on the shop drawings during this review do not relieve the contractor from compliance with requirements of the drawings and specifications. This check is only for review of the general conformance with the design concept of the project and general compliance with the information given in the contract documents. This contractor is responsible for: confirming and correlating all quantities and dimensions, selecting fabrication processes and techniques of construction; coordinating his or her work with that of all other trades and performing all in a safe and satisfactory manner.

Submittal item: Glass
 Comments: _____

Thickness (inches)	Transmittance UV %	Transmittance Visible %	Transmittance Total Solar %	Exterior Solar Reflectance %	Exterior Visible Reflectance %	Interior Visible Reflectance %	U-Value (Winter Nighttime) (Btu/hr* ² *°F)	U-Value(Summer Daytime) (Btu/hr* ² *°F)	Shading Coefficient (SC)	Solar Heat Gain Coefficient (SHGC)	Light To Solar Gain Coefficient	Thermal Stress Risk (if annealed glass)
ClimaGuard 62/27 LE on 6mm Clear(2) (CG6227C6.grd) (Guardian) Air 1/2" (12.7mm) 6mmClear_090PVB_6mmClear (Vitro Architectural Glass)												
1 1/4 "	0	57	21	39	12	13	0.28	0.26	0.30	0.26	2.19	Med

Specifications

Insulating Unit Construction

ClimaGuard 62/27 LE on 6mm Clear(2) (CG6227C6.grd) (Guardian) | Air 1/2" (12.7mm) | 6mmClear_090PVB_6mmClear (Vitro Architectural Glass)

Outdoor Lite: (Guardian) ClimaGuard 62/27 LE on 6mm Clear

Indoor Lite: (Vitro Architectural Glass) Laminate-6mmClear_090PVB_6mmClear

The results represent Center-of-Glass performance data based on ANSI/NFRC 100 and ANSI/NFRC 200 Environmental Design Conditions utilizing the LBNL Window 7.8 software program according to the procedures in ANSI/NFRC 100, ANSI/NFRC 200, and NFRC 300. Performance data is based on representative samples of factory production. Actual values may vary slightly due to variations in the production process. This data is to be used for comparison purposes and should not be considered a contract. For configurations that include drifkase components, performance results cannot be verified and should only be used as a general indication of performance. It is the recipient's responsibility to ensure the manufacturability of the above glazing configurations as well as evaluating appropriate design considerations such as wind and snow load analysis, thermal stress analysis, and local building code compliance. Vitro makes no warranty or guarantee as to the results obtained by the user and assumes no responsibility for the accuracy of the data from non-Vitro manufacturers utilized in the above simulations. Vitro recommends that a full size mockup be reviewed under the specific job-site conditions and retain the mockup as a basis of acceptable product.

Vitro Architectural Glass | 400 Guys Run Road Cheswick, PA 15024 USA | ©2001-2025 Vitro Flat Glass llc. - All Rights Reserved | [Legal Notices & Privacy Policy](#)

Atlantica, Azuria, Graylite, IdeaScapes, Optiblue, Optigray, Pacifica, Solarban, the Solarban logo, Solarblue, Solarbronze, Solarcool, Solargray, Solexia, Starphire, the Starphire logo, Sungate, Vistacool, Vitro, the Vitro logo, and the Vitro Certified network logos are registered trademarks owned by Vitro. Cradle to Cradle is a trademark of MBDC.

CrystalGray, TwilightGreen, MidnightGray, ClimaGuard, SunGuard are registered trademarks and UltraWhite is a trademark of Guardian Industries Corp.

Glass colors represented are approximate.

While Vitro has made a good faith effort to verify the reliability of this computer based tool, it may contain unknown programming errors that may result in incorrect results. The user is encouraged to use good judgment and report any questionable results to Vitro for evaluation. The applicability and subsequent results of data simulated by this tool will be compromised if the user fails to input the correct information. Vitro makes no warranty or guarantee as to the results obtained by the user of this tool and assumes no responsibility for the accuracy of the data from non-Vitro manufacturers available for simulations in this program.

YKK aP

www.ykkap.com

ProTek
YKK AP Hurricane & Blast Solutions

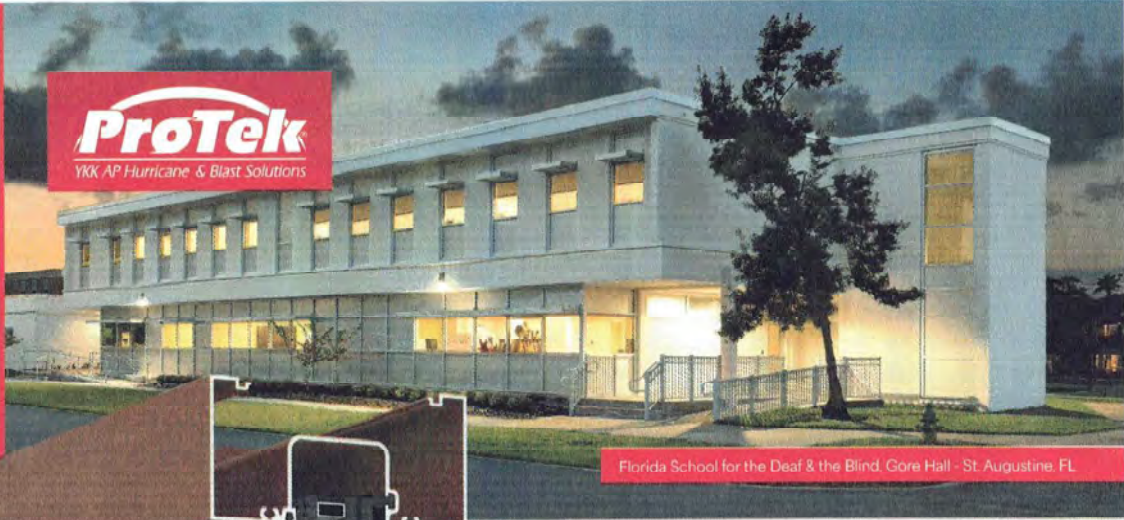

Florida School for the Deaf & the Blind, Gore Hall - St. Augustine, FL

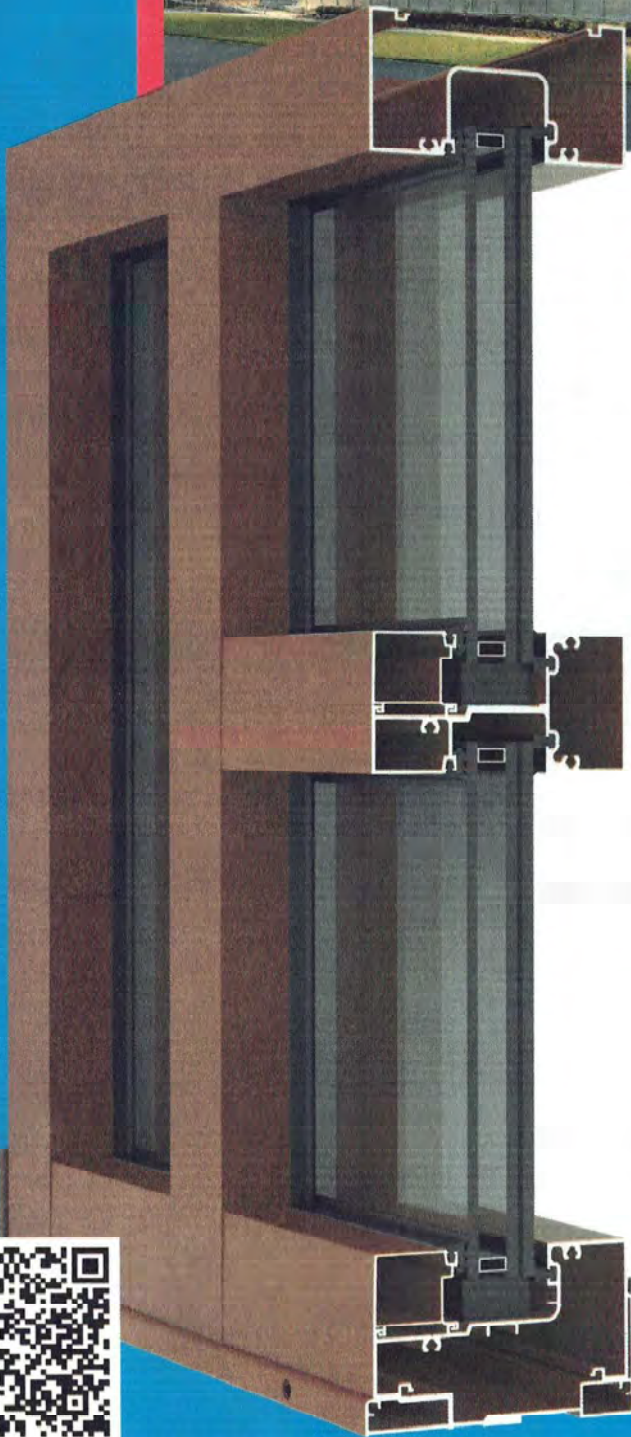

YHS 50 FI

Impact Resistant and Blast Mitigating Storefront System

The **YHS 50 FI** is a high performance storefront system designed for insulating glass that can be 1" to 1-5/16" thick. With varied infill and components, the YHS 50 can meet the demanding requirements of both Impact Resistance and Blast Mitigation. The system integrates with sun control products, vents and the H or HL series entrances.

- **Hurricane Impact** - Large & Small Missile
- Wind Zone 3 & FPA/Florida HVHZ
- Approved for Missile Level E
- **Blast Mitigation** - Static and Dynamic Analysis capability to meet DoD, GSA and VA standards
- Spans up to 144"; accomodates glass sizes up to 50 square feet
- Single and multi-span applications
- Engineered corners reduce job time
- Design Pressures up to 90 psf

Configuration:

Glazing	Glass Setting	Installation
Outside & Inside	Center Set	Screw Spline

Thermal Values:

U-Factor:	Values as low as 0.43*
CRF:	Minimum 35 frame and 59 glass

*Based on AAMA 507. Lower values may be achieved through further simulation.



YHS 50 FI SPECS		
Base Depth	5"	
Sightline	2-1/2"	
Config	Inside (Dry), Outside (Wet/Dry) / Center Set	
Tested Glass	1-5/16" Laminating IGU with Low-E (C.O.G. U-Factor: 0.29)	
Test	Results	Standards
Air Infiltration	0.06 CFM/FT ² (1.10 m ³ /h·m ²) @ 6.24 PSF (299 Pa)	ASTM E 283
Water Infiltration	Static: 12 PSF (575 Pa)	ASTM E 331
Acoustical (1-5/16" IGU)	Laminated STC: 39 Laminated OITC: 34	ASTM E 90 ASTM E 1425

Thermal Performance								
Mullion Depth	U-Factor - BTU/hr.ft ² .°F						CRF	
2-1/2" x 5" (1-5/16" Laminated IGU)	0.51	0.49	0.48	0.46	0.44	0.43	35	59
Center of Glass	0.30	0.28	0.26	0.24	0.22	0.20	Frame	Glass
AAMA 507							AAMA 1503	

Finish Options	
Type	Standard
Factory Anodized	AAMA 612
Organic Paints	AAMA 2605

Product Approvals	
Missile Level A, D, E	Wind Zone 3
Hurricane HVHZ	International ICC
Florida FBC	Texas TDI

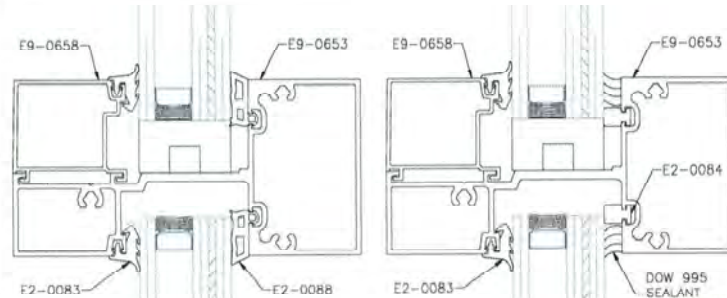

Outside, Dry Glazed

Outside, Wet Glazed

Also, an Inside, Dry Glazed configuration is available

Sill Flashing Design

- Taller back leg on sill flashing – enhanced water resistance in the field and in water testing
- Three point attachment of end dam, with a foldable tab and two screws into flashing splines
- No blind seals eliminates secondary penetration of sill and flashing when properly sealed



Missile Testing



Building codes now call for Missile E protection for essential facilities (Risk Category 4) when wind speed is 150 mph or greater. Missile E systems must withstand more than twice the impact energy compared to Missile D.

Storefront Impact Comparison

System	.060 SentryGlass 50 PSF	Design Pressure			144" Span	108" to 120" Spans	Impact Testing	
		50 PSF	65-70 PSF	90 PSF			Missile A & D	Risk Category IV Essential Facilities
YHS 50 FS								
YHS 50 FI								
YHS 50 TU								

Additional Information including CAD details, CSI specs, test reports and installation instructions are found on the Product Guide by clicking this link or visiting www.ykkap.com/commercial/productguide

**YHS 50 FS STOREFRONT FRAMING MEMBERS
LARGE MISSILE (50 PSF)**

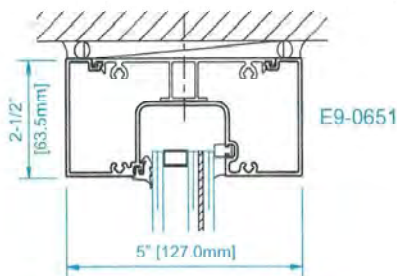
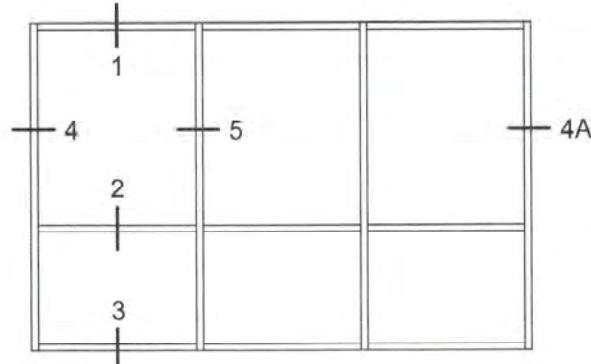

**SECTION 1
HEAD**

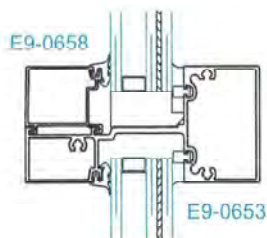

**SECTION 2
HORIZONTAL**

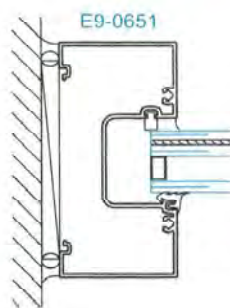

**SECTION 4
JAMB**

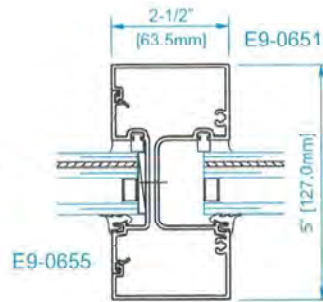

**SECTION 5
VERTICAL**

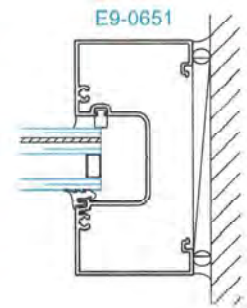

**SECTION 4A
JAMB**

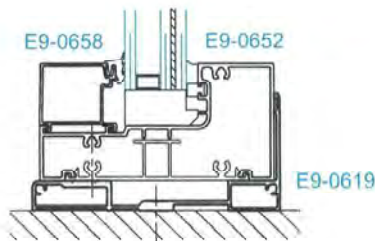

**SECTION 3
SILL**

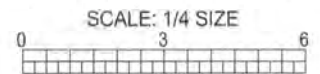

**YHS 50 FS STOREFRONT FRAMING MEMBERS
LARGE MISSILE (70 PSF)**

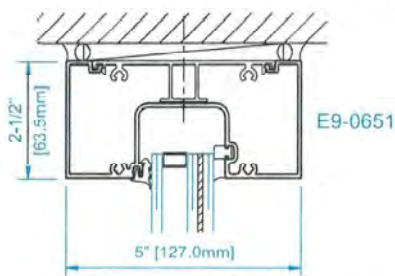
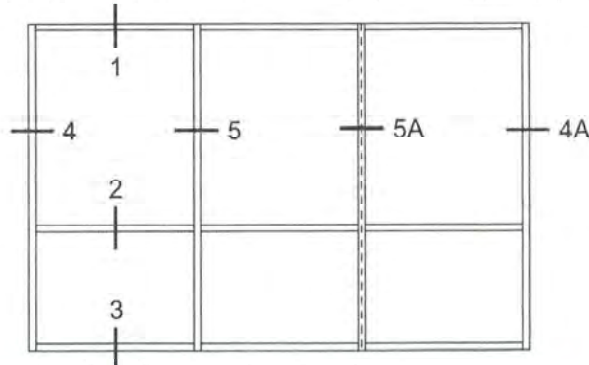

**SECTION 1
HEAD**

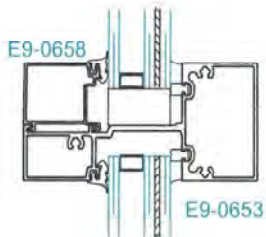

**SECTION 2
HORIZONTAL**

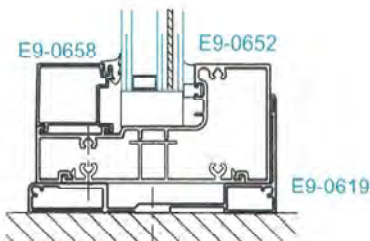

**SECTION 3
SILL**

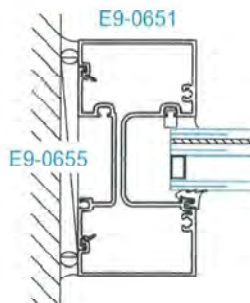

**SECTION 4
JAMB**

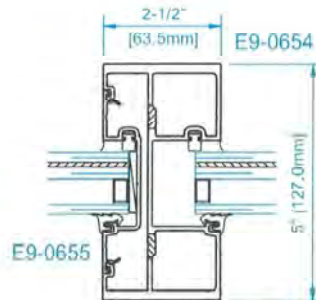

**SECTION 5
VERTICAL**

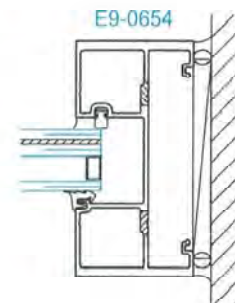

**SECTION 4A
JAMB**

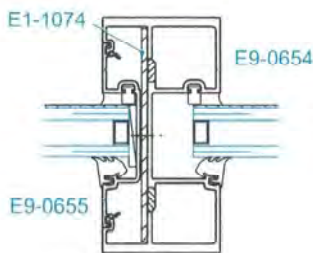

**SECTION 5A
VERTICAL w/
OPTIONAL STEEL
& 1" GLAZING**

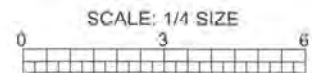

**YHS 50 FS STOREFRONT FRAMING MEMBERS
SMALL MISSILE (70 PSF)**

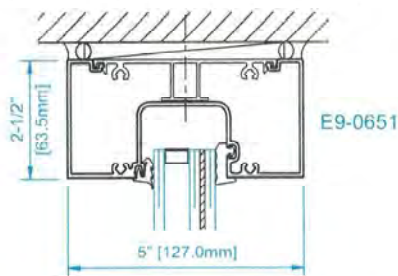
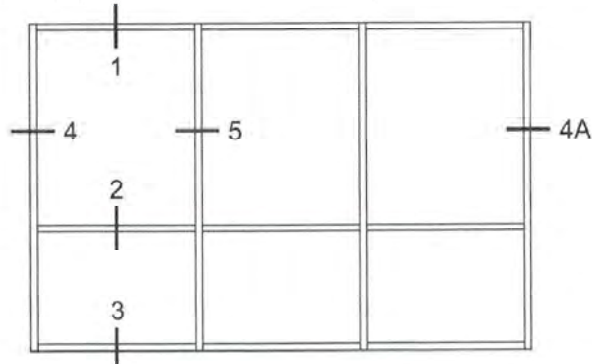

**SECTION 1
HEAD**

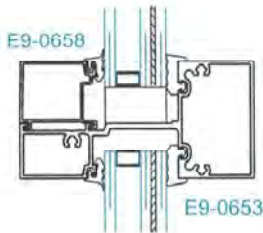

**SECTION 2
HORIZONTAL**

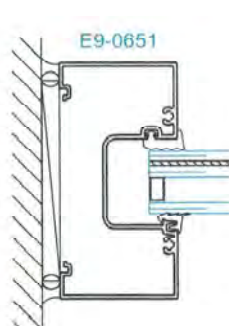

**SECTION 4
JAMB**

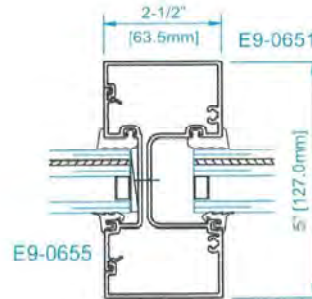

**SECTION 5
VERTICAL**

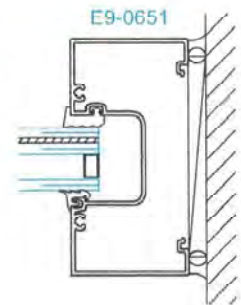

**SECTION 4A
JAMB**

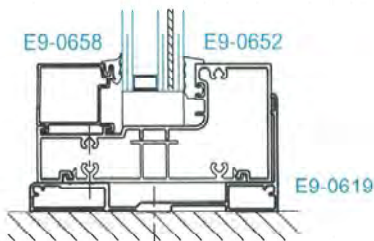

**SECTION 3
SILL**

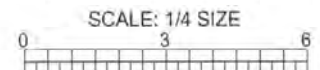

**YHS 50 FS STOREFRONT
CORNER FRAMING MEMBERS**

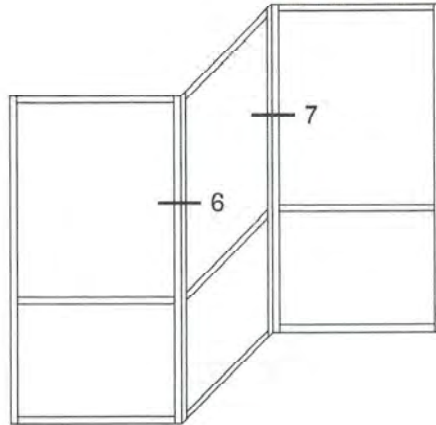

LARGE MISSILE

SMALL MISSILE

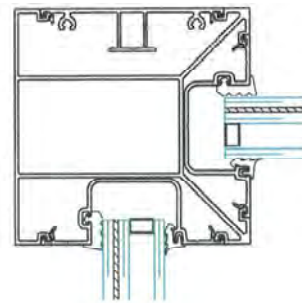
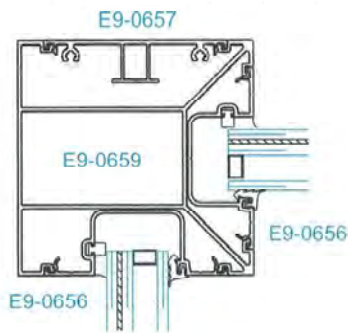

**SECTION 7
90° INSIDE CORNER**

**SECTION 7
90° INSIDE CORNER**

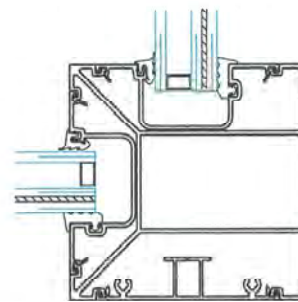
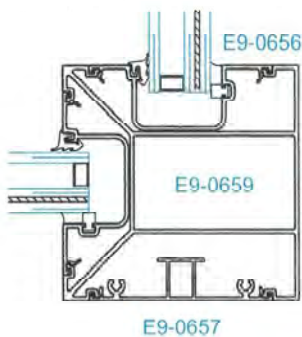

**SECTION 6
90° OUTSIDE CORNER**

**SECTION 6
90° OUTSIDE CORNER**

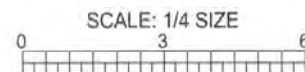

YHS 50 FS STOREFRONT DOOR FRAMING MEMBERS

*For 35H Threshold Details, See the 35H Section of this Book.

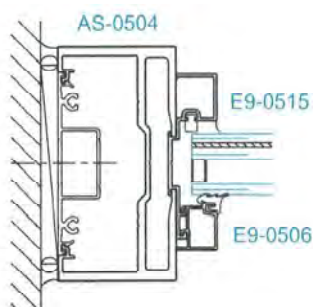
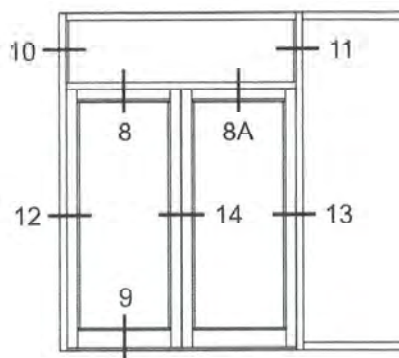
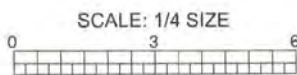

SECTION 10
JAMB @ TRANSOM
w/o SIDELITE

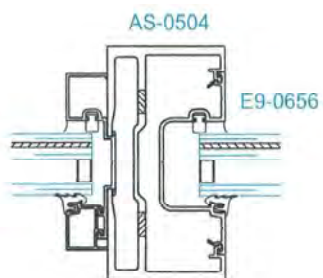

SECTION 11
JAMB @ TRANSOM
w/ SIDELITE

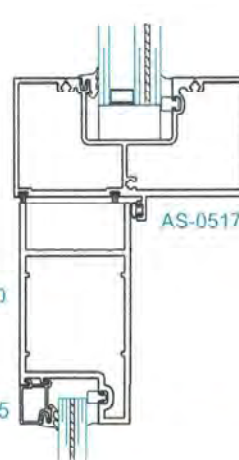

SECTION 8
TRANSOM BAR

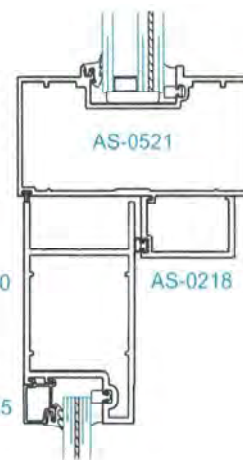

SECTION 8A
TRANSOM BAR
FOR OHCC

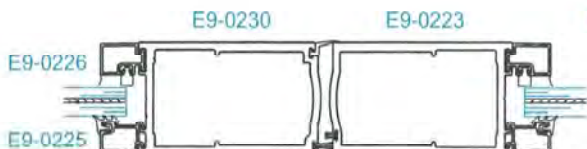

SECTION 14
MEETING STILE

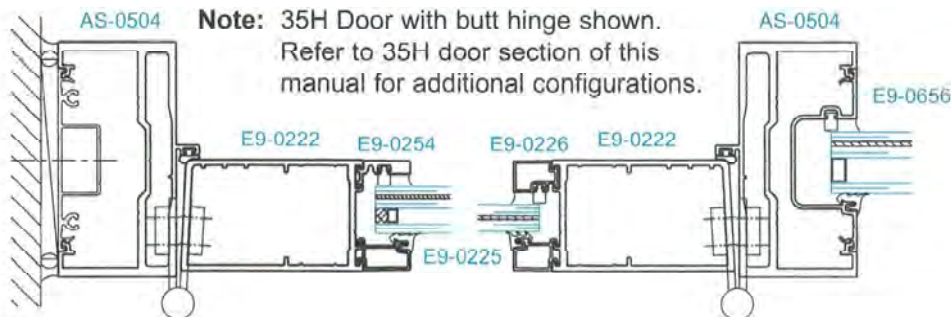

SECTION 12
DOOR JAMB w/o SIDELITE
35H INSULATING GLASS
OPTION SHOWN

SECTION 13
DOOR JAMB w/ SIDELITE

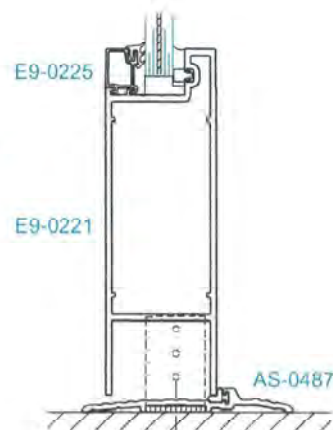

SECTION 9
AIR TIGHT THRESHOLD

Note: 35H Door with butt hinge shown. Refer to 35H door section of this manual for additional configurations.

9.0 FENSTRATION PRODUCT RATING CERTIFICATE (IP)

Certificate Authorization

Name: _____
 Signature: _____

OVERALL RATING	
U-factor:	(Btu/h·ft ² ·°F)
SHGC:	
VT:	

Company: _____
 Date: _____

STIPULATES THAT THE MATERIALS LISTED ON THIS CERTIFICATE WERE INSTALLED ON THE PROJECT IDENTIFIED BELOW

PROJECT INFORMATION:

Street Address: _____
 City: _____ State: _____ Zip: _____

GLAZING CONTRACTOR / INSTALLER:

Street Address: _____
 City: _____ State: _____ Zip: _____

Contact Person: _____
 Phone Number: _____

GLAZING MATERIAL SUPPLIER:

Street Address: _____
 City: _____
 Glass and Spacer Type: _____

Contact Person: _____
 Phone Number: _____
 State: _____ Zip: _____ # _____

Center-of-glass (C.O.G.) U-factor: _____ Btu/h·ft²·°F
 Center-of-glass (C.O.G.) SHGC: _____ Center-of-glass (C.O.G.) VT: _____

FRAMING MATERIAL SUPPLIER:

YKK AP America Inc
 Street Address: _____
 101 Marietta Street NW, Suite 2700
 City: _____
 Atlanta

Contact Person: _____
 David Warden
 Phone Number: _____
 678-838-6000
 State: _____ Zip: _____
 Georgia 30303

U-factor Matrix Btu/h·ft ² ·°F		SHGC Matrix		VT Matrix	
C.O.G. U-factor	Overall U-factor	C.O.G. SHGC	Overall SHGC	C.O.G. VT	Overall VT
0.48	0.65	0.75	0.66	0.75	0.64
0.46	0.63	0.70	0.61	0.70	0.60
0.44	0.62	0.65	0.57	0.65	0.56
0.42	0.60	0.60	0.53	0.60	0.51
0.40	0.58	0.55	0.49	0.55	0.47
0.38	0.57	0.50	0.44	0.50	0.43
0.36	0.55	0.45	0.40	0.45	0.38
0.34	0.54	0.40	0.36	0.40	0.34
0.32	0.52	0.35	0.32	0.35	0.30
0.30	0.51	0.30	0.27	0.30	0.26
0.28	0.49	0.25	0.23	0.25	0.21
0.26	0.48	0.20	0.19	0.20	0.17
0.24	0.46	0.15	0.14	0.15	0.13
0.22	0.44	0.10	0.10	0.10	0.09
0.20	0.43	0.05	0.06	0.05	0.04
0.18	0.41				
0.16	0.40				
0.14	0.38				
0.12	0.36				
0.10	0.35				

Product Line: _____
YHS 50 FI Storefront

The overall ratings for U-factor, SHGC and VT are based on a size of 78.750 in. X 78.750 in. as required in NFRC 100 and NFRC 200.

Overall U-factors, Solar Heat Gain Coefficients (SHGC) and Visible Transmittances (VT) listed in the matrix were determined in accordance with NFRC 100 and NFRC 200 respectively by an accredited, independent laboratory.

ACCREDITED INDEPENDENT LABORATORY:
Architectural Testing
 Reference NFRC 100 Report #: D5334.02-116-45
 Reference 507-07 Report #: D5334.01-116-45
 Reference AWS Test Report #: 0231-0601-01

Directions: Fill out form completely. Determine the Overall Rating for this project by using the C.O.G. U-factor (winter-time), C.O.G. SHGC, C.O.G. VT from Table 1 and looking up the overall rating from Table 2. Indicate the Overall Rating in the space above. Linear interpolation is permitted.

TABLE 1 - GLAZING

TABLE 2 - FRAMING

Quality Standards

GG 002—2015-02-23

Glass products fabricated by Trulite Glass & Aluminum Solutions™ meet the following standards and specifications:

Primary Float Glass—Meets the requirements of ASTM C 1036, *Standard Specification for Flat Glass*, including: Type 1, Class 1, Quality q3 for clear glass; and Type 1, Class 2, Quality q3 for tinted glass. The primary float glass manufacturer will be one of the following: PPG, Guardian, Pilkington.

Heat Treated Glass—Meets the requirements of ASTM C 1048, *Standard Specification for Heat-Treated Flat Glass*, for Condition A, B, or C; Quality q3, and Kind FT (Fully Tempered) or Kind HS (heat-strengthened). Unless otherwise noted, all fully tempered glass meets the safety glazing requirements of ANSI Z97.1, Class A; and CPSC 16 CFR 1201 Category II. Trulite's tempered products are certified through the Safety Glazing Certification Council (SGCC), which serves as a third party independent sponsor for overseeing of safety glazing certification and product testing. Heat treated products have a Limited Warranty from Trulite for a period of ten (10) years.

Coated Glass—Meets the requirements of ASTM C 1376, *Standard Specification for Pyrolytic and Vacuum Deposition Coatings*. Coated glass has a Limited Warranty for a period of ten (10) years, provided by the coating supplier. These include PPG, Guardian, Pilkington.

Insulating Glass—Meets the requirement of ASTM E2190 (supersedes ASTM E774, level CBA). In the case of argon filled IG units, meets ASTM E2190 with tested results of 90% before, 80% after accelerated testing. Insulating glass units are comprised of two lites of glass, separated by a dehydrated airspace, with a primary seal of poly isobutylene (PIB), and a secondary seal of silicone. Most Trulite plants carry certification to the PPG Certified Fabricator® program and the Guardian Select™ Fabricator program. Insulating glass products have a Limited Warranty for a period of (10) Years.

Spandrel Glass—Meets the requirement of ASTM C1048 for Condition B, Kind HS (Heat Strengthened) or Kind FT (Fully Tempered) for ceramic fritted coating. Spandrel glass is also available with Opaci-Coat® 300. Both products have a Limited Warranty for a period of Five (5) Years. Neither coating is recommended for 2nd or 3rd surface application in an insulating glass unit.

Laminated Glass—Meets the requirement of ASTM C 1172 *Standard Specification for Laminated Architectural Flat Glass*. When comprised of two plies of glass and a 0.030" or thicker Interlayer, Trulite's laminated glass also meets the safety criteria of CPSC 16 CFR 1201, Category II; and ANSI Z97.1, Class A. Laminated glass also complies with ASTM C 1036, and when heat-treated, with ASTM C 1048. A Limited Warranty for a period of Five (5) Years is available for laminated glass with a PVB interlayer.

Warranty

Guardian SunGuard[®] Limited Warranty

Guardian Glass warrants, to its immediate customer only, that SunGuard coated glass products (the "Products") manufactured by Guardian will not contain manufacturing defects that result in visible deterioration in the coating:

- For ten (10) years from the date of original Product shipment by Guardian, when glazed as a component of a hermetically sealed insulating glass unit ("IG unit") with the coated surface of the Product facing the interior airspace of the IG unit or when exposed to the interior of the building space if Guardian has specifically approved the Product for exposed applications; or
- For five (5) years from the date of original Product shipment by Guardian, when laminated with the coating facing the PVB if Guardian has specifically approved the Product for laminated applications.

Guardian is not responsible for any warranties that its customer provides to subsequent customers or other end users of the Product.

To make a claim under this Limited Warranty, Guardian's customer must (a) notify Guardian of any alleged defect promptly in writing at the plant from which the purchase was made (see www.guardianglass.com for plant locations) and (b) provide Guardian an opportunity to inspect the Product before its removal from any IG unit, end product, or installation/glazing system. If a Product fails to conform to this Limited Warranty, Guardian's liability is limited, at Guardian's exclusive option, to Guardian replacing the Product without charge at the original point of delivery or, in the alternative, refunding 100% of the original net selling price to its customer. This Limited Warranty does not cover labor or any other replacement, installation, or fabrication costs. The warranty period for any replacement Product supplied under this Limited Warranty extends only to the remaining warranty period on the original Product.

CONDITIONS THAT WILL VOID THIS LIMITED WARRANTY

1. The Product is broken or fractured.
2. The Product is stored, processed, installed, cleaned, or otherwise handled contrary to Guardian's written instructions and published User's Guides, Product Application Notes, or other guidelines, which are incorporated by reference into this Limited Warranty, or to applicable industry standards.
3. The Product is discarded or destroyed before reasonable opportunity for inspection by Guardian.
4. The Product is installed in an IG unit in which the seal has failed.
5. The Product is incorporated into a laminated glass unit that has delaminated.
6. The Product is damaged not due to any fault of Guardian, including for example by abnormal weather conditions; faulty installation, building construction or building design; exposure to acids, alkalis, or incompatible cleaning materials such as corrosive or abrasive compounds; or contact with abrasive items whether inside an IG unit (i.e., muntin bars, Venetian blinds, etc.) or outside (i.e., razor blades, scrapers or metallic objects).

EXCEPT FOR THE EXPRESS LIMITED WARRANTY DESCRIBED ABOVE, THERE ARE NO EXPRESS OR IMPLIED WARRANTIES OF ANY KIND AND THERE ARE NO WARRANTIES OF MERCHANTABILITY OR FITNESS FOR A PARTICULAR PURPOSE WITH RESPECT TO THE PRODUCT OR ANY PART OR COMPONENT THEREOF AND NO WARRANTY SHALL BE IMPLIED BY OPERATION OF LAW OR OTHERWISE. IN NO EVENT SHALL GUARDIAN BE LIABLE TO ANY PERSON OR ENTITY FOR INDIRECT, SPECIAL, INCIDENTAL, OR CONSEQUENTIAL DAMAGES OR CHARGES FOR ANY REASON, EVEN IF SUCH DAMAGES OR CHARGES ARE FORESEEABLE OR GUARDIAN HAS BEEN ADVISED OF THE POSSIBILITY OF SUCH DAMAGES OR CHARGES.

No variation or change from this Limited Warranty will be binding upon Guardian Glass, LLC unless made in writing specifically referencing this Limited Warranty and signed by an officer of Guardian Glass, LLC.

To learn more, call us at
1-866-GuardSG (482-7374) or visit us online
www.SunGuardGlass.com



Trulite Glass & Aluminum Solutions Laminated Glass with PVB: Limited Warranty

WARRANTY COVERAGE:

Subject to the terms and conditions set forth below, Trulite Glass & Aluminum Solutions, LLC ("Trulite"), warrants that when used in accordance with (i) our technical service bulletins and other written instructions, (ii) applicable building codes and regulations, and (iii) standard industry practices (including, without limitation, the aluminum framing manufacturer installation instructions and the proper glazing techniques set forth in The National Glass Association's (formerly GANA) Glazing Manual and Sealant Manual, as the same may be modified from time to time):

1. its laminated glass products ("Product 1") conform to *ASTM C 1172 Standard Specification for Laminated Flat Glass*;
2. its laminated glass products with minimum 0.030" PVB interlayer ("Product 2") comply with *ANSI Z97.1 (current version)* and *CPSC 16CFR 1201 II*; and
3. the Products will be free from manufacturing defects resulting in edge separation and discoloration.

This Limited Warranty shall continue for a period of ten (10) years (the "Limited Warranty Period") from the date of shipment. Notwithstanding the foregoing, this Limited Warranty shall be null and void with respect to any slope glazing application, which has not received prior written approval from the Trulite Technical Services Department. This Limited Warranty does not cover qualities or characteristics which are considered acceptable under the ASTM standard in effect at the time of purchase. This Limited Warranty shall be conditioned upon and subject to the determination of the original purchaser (the "Customer") that the Products are suitable for, and compatible with, the Customer's intended use, and such determination shall be the sole responsibility of the Customer.

EXCLUSIONS FROM WARRANTY COVERAGE:

To the extent any Product is damaged, either directly or indirectly, as a result of any of the following or is otherwise subjected to any of the following, such Product is specifically excluded from coverage under this Limited Warranty: (i) stress and strain to the Products due to the localized application of heat; (ii) edge stress due to the placement of any type of film (tint, reflective, or security); (iii) installation in a glazing system where there is no effective weep to prevent the glass edge from persistent exposure to moisture; (iv) improper usage of the Products; (v) use of incompatible cleaners, solvents, acids, alkalis or any other chemicals on or around the Products; (vi) faulty building construction or design; (vii) acts of God, including, but not limited to hurricane, flooding, earthquake or other types of natural disaster and/or abnormal weather conditions; (viii) negligent acts or omissions, or the misuse or abuse of the Products; (ix) failure to comply with our technical service bulletins and other written instructions, applicable building codes and regulations, and standard industry practices; (x) normal wear and tear of the Products resulting from usage; (xi) glass breakage, whether spontaneous, accidental or from any other cause; (xii) incompatibility with other coatings, sealants, gaskets, lubricants, insulation or any other contact materials; (xiii) scratches or abrasions to the Products; (xiv) laminated glass used as a single glazing in an exterior butt joint or exterior structural glazing system; and/or (xv) discoloration (known as "edge blush" at the edge and perimeter of the Product due to persistent exposure to moisture or contamination. This Limited Warranty will be void in the event that full payment is not received for goods and services within the agreed upon terms of sale.



LIMITATION OF LIABILITY:

THERE ARE NO EXPRESS WARRANTIES OTHER THAN THOSE CONTAINED IN THIS LIMITED WARRANTY. TO THE EXTENT PERMITTED BY LAW, ALL OTHER WARRANTIES, WHETHER EXPRESS OR IMPLIED, INCLUDING, BUT NOT LIMITED TO, THE IMPLIED WARRANTIES OF MERCHANTABILITY, FITNESS FOR A PARTICULAR PURPOSE, AND NON-INFRINGEMENT ARE EXCLUDED. ANY IMPLIED WARRANTIES ARISING BY OPERATION OF LAW ARE LIMITED IN DURATION TO THE TERM OF THIS LIMITED WARRANTY. THIS LIMITED WARRANTY CANNOT BE MODIFIED BY ANY COURSE OF DEALING, COURSE OF PERFORMANCE OR USAGE OF TRADE. FURTHER, THE REPAIR, REPLACEMENT OR REFUND AS DESCRIBED BELOW IS THE CUSTOMER'S EXCLUSIVE REMEDY. THIS REMEDY IS AVAILABLE ONLY TO THE CUSTOMER AND IS NOT TRANSFERABLE. REGARDLESS OF THE TYPE OF CLAIM (WHETHER BASED IN CONTRACT, INFRINGEMENT, NEGLIGENCE, STRICT LIABILITY, TORT OR OTHERWISE), TRULITE'S LIABILITY TO CUSTOMER SHALL NOT EXCEED THE AMOUNT PAID BY THE CUSTOMER TO TRULITE ON SUCH PURCHASE ORDER.

OTHER LIMITATIONS OF THIS WARRANTY:

Trulite shall not be liable to the Customer or anyone else for consequential, incidental, special, exemplary, indirect, or punitive damages, including, without limitation, lost profits, labor costs, or any other pecuniary damage resulting from or related to personal injury, death, property damage, whether due to any defect, delay, non-delivery, non-performance, recall, breach, or other reason. All claims in tort, strict liability, and failure of essential purpose are waived and excluded, including claims of damage allegedly caused by Trulite's negligence. Except as expressly set forth in this Limited Warranty, Trulite shall not be liable to the Customer in tort, strict liability, or any other legal or equitable theory for any alleged defect in the design, manufacture or materials of the Product or for the omission or alleged inadequacy of any warning related to the Product. Except for this Limited Warranty, the Customer accepts the Products "AS IS" with all faults and assumes the risk of loss for any defect or nonconformity. There are no third-party beneficiaries to this Limited Warranty. Customer acknowledges and declares that these limitations and waivers have been brought to the Customer's attention and explained, that the Customer has read and understood all terms and agrees to be so bound, and that the Customer's receipt of the Products and this Limited Warranty signifies that the Customer has voluntarily and knowingly consented to all terms, including the waivers and limitations contained within this Limited Warranty.

Warranties for products manufactured or supplied to Trulite by third parties shall be limited to the third party manufacturer's warranty, and Trulite will not be responsible for any freight or labor charges in connection with any third party warranty claims.

THE CUSTOMER'S EXCLUSIVE REMEDY:

If a Product is proven defective within the Limited Warranty Period, then as the Customer's sole remedy, Trulite will, at its sole option, either: (A) replace the defective Product without charge, FOB to the Trulite location nearest to the place of installation; or (B) refund the purchase price of the defective Product. Trulite will not be liable for any other expenses involved in the removal of such Product, installation of a replacement Product, or any other incidental or consequential damages, including, without limitation, attorney's fees, transportation costs or labor. The warranty for any replacement Product shall be limited to the terms and conditions of this Limited Warranty and shall continue for the period of time remaining under the original Limited Warranty Period provided in this Limited Warranty.

THE CUSTOMER'S WARRANTY IS NON-TRANSFERRABLE:

This Limited Warranty (i) is limited to the Customer to whom the Product was sold by Trulite and is nontransferable, nonassignable and cannot be extended by operation of law or otherwise beyond the Customer; (ii) replaces all previous warranties; and (iii) applies only to purchases and installations within the United States.



FILING A CLAIM:

To file a claim under this Limited Warranty, the Customer must contact us, in writing, within fifteen (15) calendar days of the discovery of an alleged manufacturing defect in a Product, at Trulite Glass & Aluminum Solutions LLC, Attn: Technical Services Department, 403 Westpark Ct. Suite 201, Peachtree City, GA 30269, although Trulite may change this address by written notice to the Customer as provided on Trulite's website. Proof of purchase from the Customer must be submitted with any notice of claim. We have the right to physically inspect an installation site and obtain samples from that job installation and of the Products used in that installation before we determine the validity of the Customer's claim. The Customer shall provide Trulite with reasonable access to the Products, installation site and such other information as Trulite may reasonably request in connection with its investigation. The Customer's claim must be received and evaluated by us before any repair or replacement work is performed; otherwise, this Limited Warranty will be null and void. No one except the CEO of Trulite has the authority to (i) change, modify or extend this Limited Warranty in any respect, or (ii) assume any other liability or obligation on Trulite's behalf.

THIS WARRANTY IS GOVERNED BY GEORGIA LAW:

In providing this Limited Warranty, Trulite and the Customer agree that Georgia law governs this Limited Warranty, including Title 11, Official Code of Georgia Annotated, § 11-2-101, *et seq.* This Limited Warranty shall be governed by and interpreted according to Georgia law, without giving effect to conflict of law principles. Except as provided above, any action or claim arising out of or relating to this Limited Warranty may be brought, if at all, in a federal or state court in Atlanta (Fulton County), Georgia having subject matter jurisdiction over the matter, and the Customer irrevocably consents to the jurisdiction of that court and waives any objection that the court in Atlanta is an inconvenient forum. At Trulite's sole election, any dispute arising out of or related to this Limited Warranty shall be submitted to binding arbitration in Atlanta, Georgia in accordance with the rules of the American Arbitration Association. Any award ordered in such arbitration shall be enforceable in any court of competent jurisdiction.



Trulite Glass & Aluminum Solutions Dual Seal Insulating Glass: Limited Warranty

WARRANTY COVERAGE:

Subject to the terms and conditions set forth below, Trulite Glass & Aluminum Solutions, LLC ("Trulite"), warrants that its dual seal insulating glass products and/or insulating glass units (the "Products" and each a "Product"), when used in accordance with (i) our technical service bulletins and other written instructions, (ii) applicable building codes and regulations, and (iii) standard industry practices, will be free from manufacturing defects resulting in material obstruction of the vision area due to flaking, peeling, the infiltration of dirt or dust, or the formation of any film on the internal glass surfaces due to the intrusion of moisture into the dehydrated air space.

This Limited Warranty shall continue for a period of ten (10) years (the "Limited Warranty Period") from the date of shipment. This Limited Warranty shall be conditioned upon and subject to the installer, general contractor, architect of record or owner's (each a "Customer") determination that the Product is suitable for and compatible with the Customer's intended use, and such determination shall be the sole responsibility of the Customer.

EXCLUSIONS FROM WARRANTY COVERAGE:

The following are specifically excluded from coverage under this Limited Warranty:

- (i) Products that: measure in excess of sixty (60) square feet; have been retrofitted; have been installed in a vehicle that may incur high vibration; utilize solely Lexan®, polycarbonate, non-glass laminates, acrylic or other plastic materials as a component lite; or contain unsealed capillary tubes;
- (ii) any laminated portion of the Product and
- (iii) the failure of, damage to, or defects in the Products resulting from or caused by: the placement of any type of aftermarket film; improper usage; installations in or around swimming pool enclosures, green houses or any other environment that has continuous or cyclical high moisture; use of cleaners, solvents, acids, alkalis or any other chemicals on or around finished Products; faulty building construction or design; glass breakage, whether spontaneous, accidental or from any other cause; Acts of God, including, but not limited to hurricanes, flooding, earthquakes or other types of natural disasters and/or abnormal weather conditions; acts of negligence, or the misuse or abuse of the Product; improper installation; failure to comply with our technical data sheets and other written instructions, applicable building codes and regulations, and standard industry practices; incompatibility with other coatings, sealants, gaskets, lubricants, insulation or any other materials; normal wear and tear due to usage; and scratches or abrasions to the Products.

This Limited Warranty will be null and void in the event that full payment is not received for goods and services within the agreed upon terms of sale.

LIMITATION OF LIABILITY:

THERE ARE NO EXPRESS WARRANTIES OTHER THAN THOSE CONTAINED IN THIS LIMITED WARRANTY. TO THE EXTENT PERMITTED BY LAW, ALL OTHER WARRANTIES, WHETHER EXPRESS OR IMPLIED, INCLUDING, BUT NOT LIMITED TO, THE IMPLIED WARRANTIES OF MERCHANTABILITY AND FITNESS FOR A PARTICULAR PURPOSE ARE EXCLUDED. ANY IMPLIED WARRANTIES ARISING BY OPERATION OF LAW ARE LIMITED IN DURATION TO THE TERM OF THIS LIMITED WARRANTY. NO IMPLIED WARRANTY CAN BE MODIFIED BY ANY COURSE OF DEALING, COURSE OF PERFORMANCE OR USAGE OF TRADE. FURTHER, THE REPAIR, REPLACEMENT OR REFUND AS DESCRIBED BELOW IS THE EXCLUSIVE REMEDY, AND THIS REMEDY IS AVAILABLE ONLY TO THE CUSTOMER.

OTHER LIMITATIONS OF THIS WARRANTY:

Trulite shall not be liable to the Customer or anyone else for consequential, incidental, special, exemplary, indirect, or punitive damages, including, without limitation, lost profits, labor costs, or any other pecuniary damage resulting from or related to personal injury, death, property damage, whether due to any defect, delay, nondelivery, nonperformance, recall, breach, or other reason. All claims in tort, strict liability, and failure of essential purpose are waived and excluded, including claims of damage assertedly caused by Trulite's negligence. Except for as set forth in this Limited Warranty, Trulite shall not be liable to the Customer in tort, strict liability, or any other legal or



equitable theory for any alleged defect in the design or manufacture of the Product or for the omission or alleged inadequacy of any warning related to the Product. Except for this Limited Warranty, the Customer accepts the Products "as is" with all faults and assumes the risk of loss for any defect or nonconformity. There are no third-party beneficiaries to this Limited Warranty. Customer acknowledges and declares that these limitations and waivers have been brought to the Customer's attention and explained, that the Customer has read and understood all terms and agrees to be so bound, and that the Customer's receipt of the Products and this Limited Warranty signifies that the Customer has voluntarily and knowingly consented to all terms, including the waivers and limitations contained within this Limited Warranty.

THE CUSTOMER'S EXCLUSIVE REMEDY:

If a Product is proven defective within the Limited Warranty Period, then as the Customer's sole remedy, Trulite either will: (A) replace the defective Product without charge, FOB to the Trulite location nearest to the place of installation or; (B) at Trulite's option, refund the purchase price of the defective Product. Trulite will not be liable for any other expenses involved in the removal of such Product, installation of a replacement Product, or any other incidental or consequential damages, including, without limitation, attorney's fees, transportation costs or labor. The warranty for any replacement Product shall be limited to the terms and conditions of this Limited Warranty and shall continue for a period of time equal to the remainder of the Limited Warranty Period provided in this Limited Warranty.

THE CUSTOMER'S WARRANTY IS NON-TRANSFERRABLE:

For multiple business reasons, including the duty to care and maintain the Product appropriately, this Limited Warranty (unless Trulite agrees, in a written agreement signed by Trulite, with the Customer to amend this provision): (i) is limited to the Customer to whom the Product was sold and is nontransferable, nonassignable and cannot be extended by operation of law or otherwise beyond the Customer; (ii) replaces all previous warranties; and (iii) applies only to purchases and installations within the United States on or after September 1, 2016.

FILING A CLAIM:

To file a claim under this Limited Warranty, the Customer must contact us, in writing, within fifteen (15) calendar days of the discovery of an alleged manufacturing defect in a Product, at Trulite Glass & Aluminum Solutions LLC, Attn: Technical Services Department, 403 Westpark Ct. Suite 201, Peachtree City, GA 30269, although Trulite may change this address by written notice to the Customer as provided on Trulite's website. Proof of purchase from the Customer must be submitted with any notice of claim. We have the right to physically inspect an installation site and obtain samples from that job installation and of the Products used in that installation before we determine the validity of the Customer's claim. The Customer's claim must be received and evaluated by us before any repair or replacement work is performed; otherwise, this Limited Warranty will be null and void. For additional information regarding our warranty policy, please refer to our website at www.trulite.com.

THIS WARRANTY IS GOVERNED BY GEORGIA LAW:

In providing this Limited Warranty, Trulite and the Customer agree that Georgia law governs this Limited Warranty, including Title 11, Official Code of Georgia Annotated, § 11-2-101, *et seq.* This Limited Warranty shall be governed by and interpreted according to Georgia law, without giving effect to conflict of law principles. Except as provided above, any action or claim arising out of or relating to this Limited Warranty may be brought, if at all, in a federal or state court in Atlanta (Fulton County), Georgia having subject matter jurisdiction over the matter, and the Customer irrevocably consents to the jurisdiction of that court and waives any objection that the court in Atlanta is an inconvenient forum. At Trulite's sole election, any dispute arising out of or related to this Limited Warranty shall be submitted to binding arbitration in Atlanta, Georgia in accordance with the rules of the American Arbitration Association. Any award ordered in such arbitration shall be enforceable in any court of competent jurisdiction.

Customer Name: A-1 Glass
Job Name: Prosper Apartments
Job Address: 408 W 5th Street
Ship Date: DOSC 5/20/2025
Provided by: Danny Guilbeau