

DAMMON

ENGINEERING, INC.

554 Old Spanish Trail
Slidell, LA 70458
985.649.5832

www.dammonengineering.com
info@dammonengineering.com

Architects & Engineers

SHOP DRAWING and SAMPLE TRANSMITTAL

DATE: 6/19/2025

TO: Cheri Rush
M Natal Contractor, Inc.
P.O. Box 518
Slidell, La

FROM: Chuck Dammon

SUBMITTAL No.: 220000.001.0

REFERENCE: **STP Fire District 1 Training Center**

DE Project: 2507

WE TRANSMIT:

enclosed under separate cover _____

FOR YOUR:

use record approval
 review and comment information drafting

THE FOLLOWING:

drawing(s) contracts specifications
 shop drawings samples change order(s)
 product information warranty substitution request

# COPIES	DESCRIPTION	ACTION
Electronic	Plumbing	A

ACTION CODES:

- A. Reviewed/No Exceptions
- B. Reviewed/Exceptions Noted
- C. Revise and Resubmit
- G. Rejected
- D. No Action Required
- E. For Signature and Return to this Office
- F. See Remarks Below

REMARKS:

Plumbing

COPIES TO: File



Project: STFD No.1 New Training Facility-Slidell #2
 34780 S. Range Road
 Slidell, Louisiana 70460

SUBMITTAL COVER SHEET

Arch. Project No: _____

MNC Project No: 830

To: Dammon Engineering, Inc.
554 Old Spanish Trail
Slidell, Louisiana 70458
info@dammonengineering.com

From: Cheri Rusich
M Natal Contractor, Inc.
P.O. Box 518
Slidell, LA 70459

Attn. David Dammon
Chuck Dammon

Sent Via E-Mail

General Contractor's Review:

M Natal Contractor, Inc.

SUBMITTAL NO: <u>220000.001.0</u>	CONTRACTOR'S REVIEW:
SPEC. SEC. NO: <u>22000</u>	NO EXCEPTIONS TAKEN <input checked="" type="checkbox"/>
VENDOR/SUB: <u>Lavigne</u>	FURNISH AS CORRECTED <input type="checkbox"/>
DESCRIPTION: <u>Plumbing- P.D.</u>	REJECTED; RESUBMIT <input type="checkbox"/>
	PARTIAL APPROVAL; SUBMIT ADD'L ITEM(S) <input type="checkbox"/>

Reviewing is for conformance with the design concept of the project and compliance with the information given in the Contract Documents. The Vendor/Subcontractor is responsible for dimensions to be confirmed and correlated at the site for information that pertains solely to the fabrication process or to the means, method, technician, sequences, and procedures of construction; and for coordination of the work with all trades.

BY Cheri Rusich DATE: 06/09/2025

Architect/Engineer Review:

*G.H. to send to Chalk
 α M 6-9-25*

DAMMON ENGINEERING, INC

Date: 06-19-25 Project: Training Facility #2
 Reviewed: X
 Reviewed as noted: _____
 Revise and ReSubmit: _____
 Rejected: _____
 Other: _____

Correction or comments made on the shop drawings during this review do not relieve the contractor from compliance with requirements of the drawings and specifications. This check is only for review of the general conformance with the design concept of the project and general compliance with the information given in the contract documents. This contractor is responsible for: confirming and correlating all quantities and dimensions, selecting fabrication processes and techniques of construction; coordinating his or her work with that of all other trades and performing all in a safe and satisfactory manner.

Submittal item: Plumbing
 Comments: _____

Plumbing Submittal

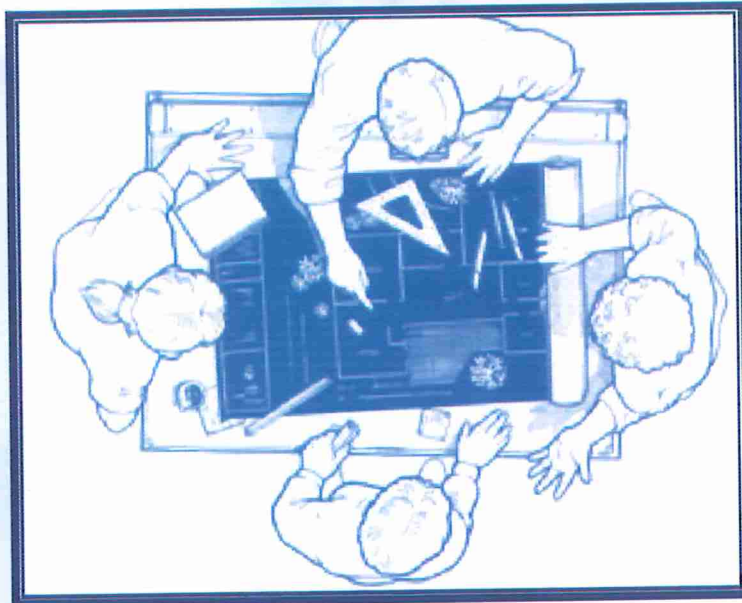

Fire Training Center

Submitted by

Lavigne Mechanical

6/4/2025

THE PLUMBING WAREHOUSE

113 PRODUCTION DRIVE
SLIDELL, LA 70460
Phone: 985 781-8342
Fax: 985 781-8343
www.tpwslidell.com

Spec#**Table of Contents**

1	1465648	DELTA R10000-UNBX T&S RGH-IN VLV
2	1463095	DELTA T13220 MONITOR 13 SER CHROME 1.75 GPM SGL LEVER HDL PRESS BAL SHOWER TRIM KIT WTRSENSE ADA
3	2109681	GERBER G0012834CH MAXWELL WHT 20 5/8 X 17 3/4IN OVAL 3H 4 IN. CENTERSET VC DROP-IN BATH SINK W/ OVERFLOW
4	4339208	LUXART LXNZS3219 16GA SS BR SATIN 32 X 18-7/8 X 10 UM NEAR ZERO RADIUS SGL BOWL KITCHEN SINK
5	3811129	KOHLER K-96057-0 WHT HIGHCLIFF ULTRA TOP SPUD ADA ELONG TOILET BOWL
6	220738	SLOAN 3080053 111XL REGAL EXPOSED 1X11-1/2 1.6GPF TOILET FLUSH VLV VR F/ FM OR WH TOP SPUD BOWLS ADA COMPLIANT
7	4893232	MAINLINE CH211-CP POL CHROME CHELMSFORD 1.2 GPM 3H DM 4CC SGL METAL LEVER HDL LAV FCT ADA APPROVED LEAD FREE
8	1255862	ZURN Z1996-24 24X24 PVC MOP SVC BASIN W/ 3 PVC DRAIN
9	686283	TSBRASS B-0665-BSTR RGH CHROME 12.96 GPM 2H 8 IN. CENTERSET WM DBL LEVER HDL SVC FCT
10	3539479	RHEEM PROE40-M2-RH95 650265 40GAL MED CLASSIC ELEC 240V 1PH 4.5KW/4.5KW NON-SIM 2-WIRE UPPER COP/ LOWER SS ELEMENT WTR HTR W/ T&P VLV INSTALLED NAECA III 6 YEAR TANK/PARTS 481/4H 201/4D
11	2968074	MAINLINE ML1055000 WHT ELONG PLAS OPEN FRONT TOILET SEAT W/ CHECK HINGE & SS HARDWARE L/ COVER
12	3606810	HYDRAPRO H10000 2.0GAL HPTET2 THERMAL EXPANSION TANK
13	1043731	DEARBORN 760-1 11/4X6 CP 17GA TAILPIECE GRID DRAIN
14	775122	DEARBORN 831-1 11/4 CP 17GA TRAP PRIMER TAILPIECE
15	4791344	MAINLINE LB137F3-CP POL CHROM LISBURN 1.8 GPM 1H DM SGL METAL LEVER HDL KITCHEN FCT W/ PULL- DOWN 3 FUNCTION SPRAY & CERAMIC DISC CARTRIDGE ADA APPROVED LEAD FREE

Disclaimer:

The specification sheets provided herein were written and provided by the product's manufacturer and not by Hajoca Corporation. Consequently, Hajoca Corporation cannot assume and disclaims any responsibility for errors, omissions or any misstatements in the product specifications provided herein.

Spec#

Table of Contents

16

4633674 ELKAY LZS8WSLK_UCO EZH20 WTR COOLER KIT-UNIV
CNTRL OK

Disclaimer:

The specification sheets provided herein were written and provided by the product's manufacturer and not by Hajoca Corporation. Consequently, Hajoca Corporation cannot assume and disclaims any responsibility for errors, omissions or any misstatements in the product specifications provided herein.



see what Delta can do™

MULTICHOICE® UNIVERSAL ROUGH VALVE BODY

1465648

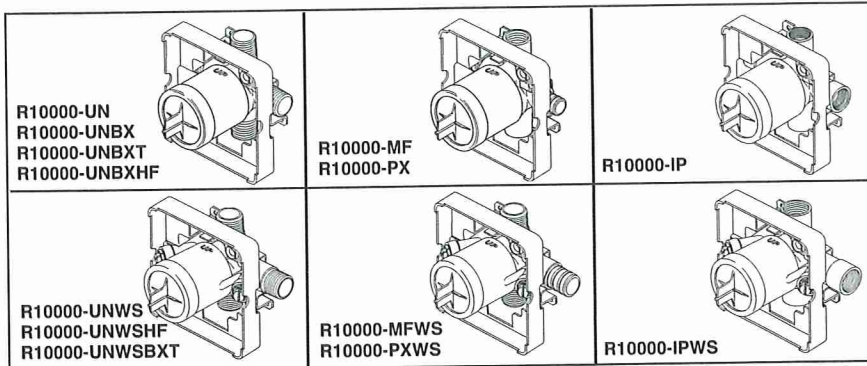

Submitted Model No.: _____

Specific Features: _____

- R10000-UN (Universal Inlets/Outlets)
- R10000-UNBX (Universal Single Box Model)
- R10000-UNBXHF (High Flow Shower Only)
- R10000-UNBXT (Thin Wall)
- R10000-UNWS (Universal with Stops)
- R10000-UNWSHF (High Flow with Stops)
- R10000-UNWSBXT (Thin Wall with Stops)
- R10000-PX (Pex Crimp Connections with UN Outlets)
- R10000-PXWS (Pex Crimp Connections with Stop with UN Outlets)
- R10000-IP (IPS Inlets/Outlets)
- R10000-IPWS (IPS with Stops)
- R10000-MF (Pex Cold Expansion Connections with UN Outlets)
- R10000-MFWS (Pex Cold Expansion with Stops with UN Outlets)

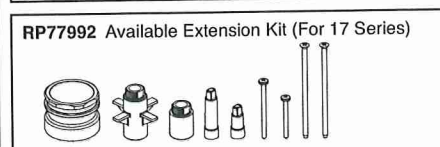
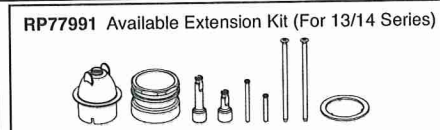
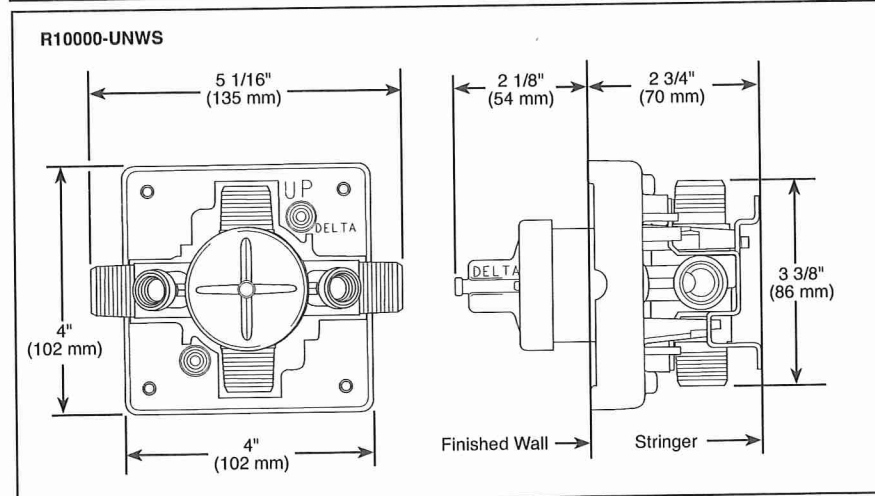
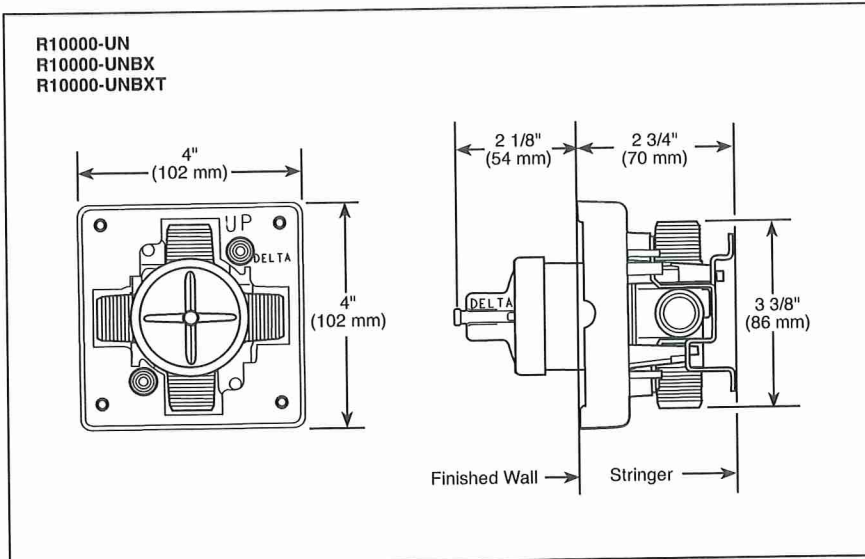

STANDARD SPECIFICATIONS:

- Forged brass body.
- Back-to-Back installation capabilities.
- Can be tested with air (200 PSI) or water (300 PSI) without valve using supplied test cap.
- Square plasterguard allows for right angle cuts.
- Thin wall mounting.
- For use with MultiChoice® Universal single or dual function trim. Cartridge ships with trim.
- 1/2" outlets and connections.

Note: No tub outlet in HF model.

Note: Should use proper fitting with each type (copper tubing, iron pipe, and pex fitting).

Note: Should use proper tooling with crimping pex fitting and cold expansion pex models.

Note: IP indicates female 1/2" threaded connections.

Note: UN indicates Universal type fitting and is 1/2" NPT male thread with 1/2" C.W.T. female sweat.

WARRANTY

- Lifetime limited warranty on parts (other than electronic parts and batteries) and finishes: or, for commercial users, for 5 years from date of purchase.
- 5 year limited warranty on electronic parts (other than batteries); or, for commercial users, for 1 year from the date of purchase. No warranty is provided on batteries.

COMPLIES WITH:

- ASME A112.18.1 / CSA B125.1

Delta Faucet Company
 55 E. 111th Street, Indianapolis, IN 46280
 350 South Edgeware Road, St. Thomas, ON N5P
 © 2017 Delta Faucet Company



Delta reserves the right (1) to make changes in specifications and materials, and (2) to change or discontinue models, both without notice or obligation. Dimensions are for reference only. See current full-line price book or www.deltafaucet.com for finish options and product availability.



see what Delta can do™ TUB AND SHOWER FAUCET TRIM

- Classic Bath Collection
- Valve Only (T13020 Series)
- Tub Only (T13120 Series)
- Shower Only (T13220 Series)

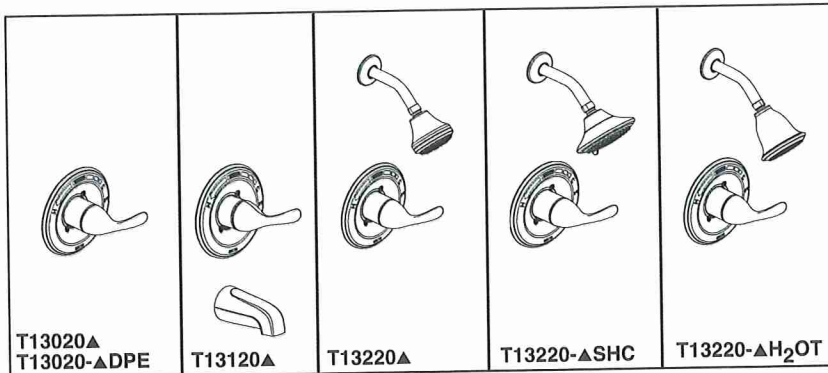

Submitted Model No.: _____
Specific Features: _____

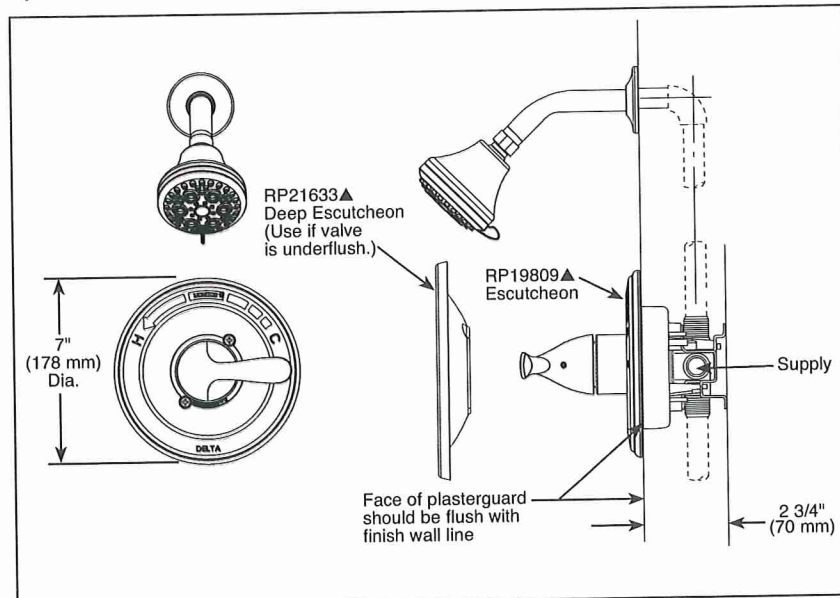

RP78575▲ 1.75 GPM
Touch-Clean® Shower Head

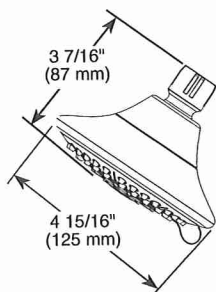

52634-18-PK▲ 1.75 GPM
Touch-Clean® Shower Head

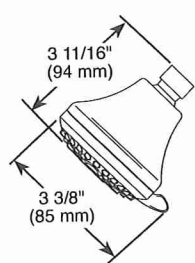

52658-PK▲ 1.5 GPM
Shower Head

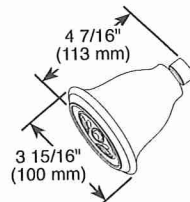

RP48717▲

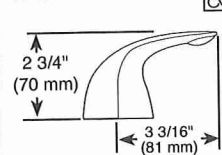

RP77991 Available Extension Kit



FEATURES:

- 13 Series pressure balanced bath mixing valve trim
- "H2O" models include H₂Okinetic® Technology shower head

STANDARD SPECIFICATIONS:

- Maintains a balanced pressure of hot and cold water even when a valve is turned on or off elsewhere in the system.
- For use with MultiChoice® Universal rough valve body. (R10000 Series)
- Back-to-back installation capability
- Solid brass forged body
- Temperature only controlled with metal lever handle
- Field adjustable to limit handle rotation into hot water zone
- 120° maximum handle rotation
- All parts replaceable from the front of the valve
- T13220-H2OT uses 52658-PK
- DPE = 1" deeper escutcheon (RP21633)
- Stem extension kit RP77991 can be ordered to allow for an additional 1 3/4" wall thickness. RP77991 ships with chrome escutcheon screws. For special finishes also order RP12630 escutcheon screws in desired finish.
- Shower head max flow rate 1.5 gpm @ 80 psi, 5.7 L/min @ 550 kPa (T13220-H2OT)
- Shower head max flow rate 1.75 gpm @ 80 psi, 6.6 L/min @ 550 kPa (T13020, T13020-DPE, T13220, T13220-SHC)
- **Note:** Product will be marked with flow rate of specific shower head

WARRANTY

- Parts and Finish - Lifetime limited warranty; or for commercial purchasers, 10 years for multi-family residential (apartments and condominiums) and 5 years for all other commercial uses, in each case from the date of purchase.
- Electronic Parts and Batteries (if applicable) - 5 years from the date of purchase; or for commercial purchasers, 1 year from the date of purchase. No warranty is provided on batteries.



COMPLIES WITH:

- ASME A112.18.1 / CSA B125.1
- ASSE 1016
- Indicates compliance to ICC/ANSI A117.1 - Valve control only
- EPA WaterSense®

▲ Designate proper finish suffix
Delta reserves the right (1) to make changes in specifications and materials, and (2) to change or discontinue models, both without notice or obligation. Dimensions are for reference only. See current full-line price book or www.deltafaucet.com for finish options and product availability.
DSP-B-T13020 Rev. T

1463095

GERBER

**MAXWELL®
Drop-in Sink**

Features:

G0012831CH / G0012834CH / G0012838CH

- Vitreous China
- Drop-in sink
- ADA compliant
- Front Overflow
- Oval design with curved basin
- Faucet and Drain not included

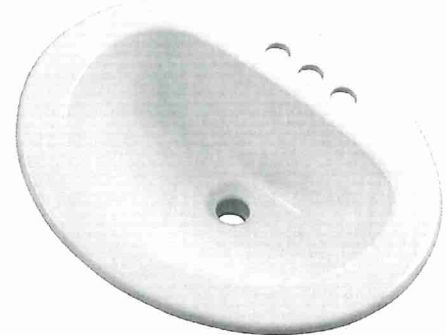

G0012834CH Shown

Technical Information:

Sink	G0012831CH	G0012834CH	G0012838CH
Configuration	Single Hole	4" Centers	8" Centers
Height	8 1/8"		
Width	20 5/8"		
Depth	17 3/4"		
Inside Basin	15 7/8" x 11 1/8"		
Shipping Weight	18.5 lbs		

Accessories To Be Purchased Separately:

N/A

Available Colors:

- White
- Other: Refer to Price Book for additional colors/finishes

Warranty:

- Limited Lifetime on Vitreous China, refer to the website for more details.

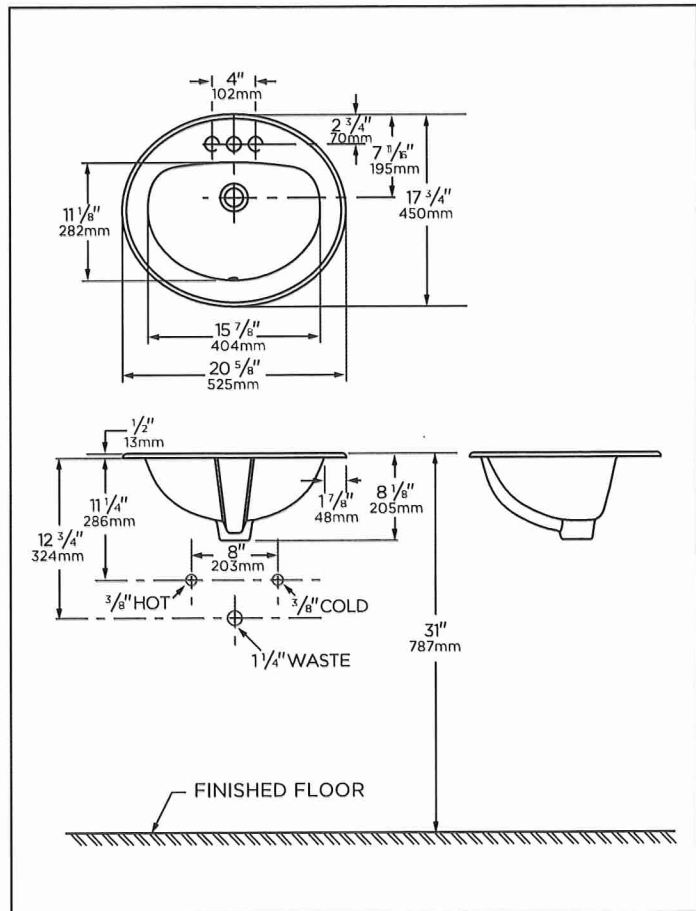
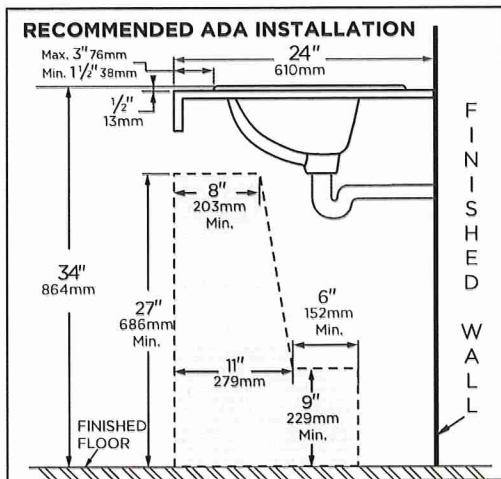

NOTES: All dimensions are in inches and millimeters. Illustrations may not be drawn to scale.

IMPORTANT:

Dimensions of fixtures are nominal and may vary within the range of tolerances established by ASME standard A112.19.2/CSA B45.1

Because we are committed to continual product improvement, specifications are subject to change without notice.

© 2020 Gerber Plumbing Fixtures LLC. All rights reserved gerber-us.com gerber-ca.com

The Plumbing Warehouse
LIER

2109681

GERBER**MAXWELL®**
Lavabo encastré**Caractéristiques :****G0012831CH / G0012834CH / G0012838CH**

- En porcelaine vitrifiée
- Évier encastré
- Conformité à l'ADA
- Trop-plein à l'avant
- Conception ovale avec un bassin courbé
- Robinet et drain non inclus

Informations techniques :

Lavabo	G0012831CH	G0012834CH	G0012838CH
Configuration	Un trou	Entraxe de 4 po (10,2 cm)	Entraxe de 8 po (20,3 cm)
Hauteur	8 1/8 po (205mm)		
Largeur	20 5/8 po (525mm)		
Profondeur	17 3/4 po (450mm)		
Intérieur de lavabo	15 7/8 x 11 1/8 po (404 x 282mm)		
Poids d'expédition	18.5 lb (8,39 kg)		

Accessoires à acheter séparément :

SO

Couleurs disponibles :

- Blanc
- Autres : consultez le guide de prix pour les autres couleurs/finis disponibles

Garantie :

- Limitée à vie sur porcelaine vitrifiée, consultez le site Web pour plus de détails.

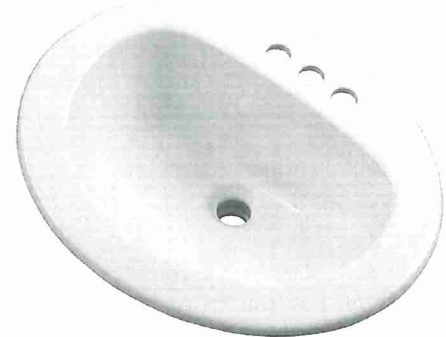

G0012834CH montrée

2109681

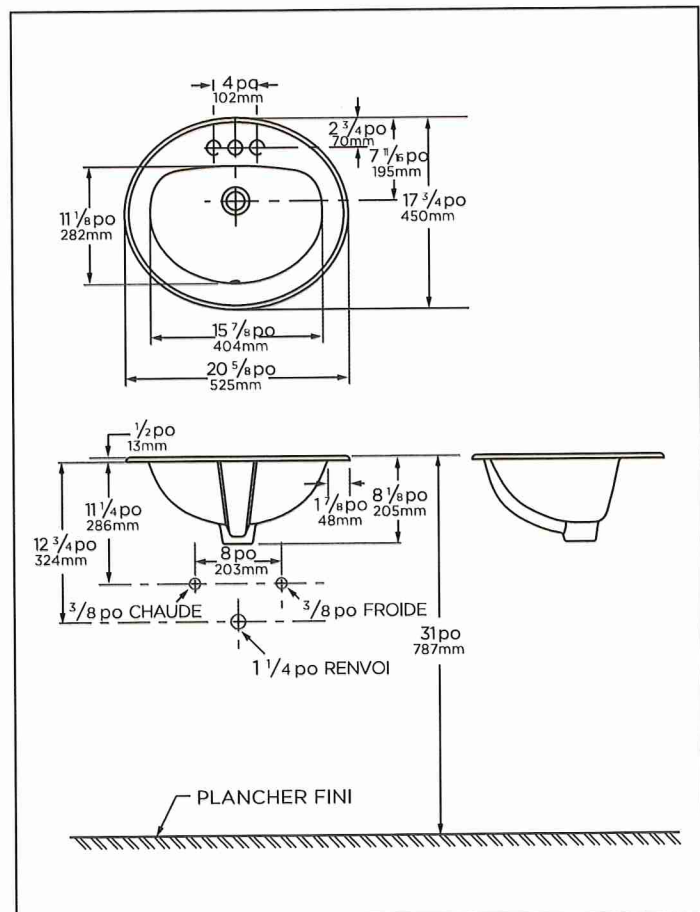
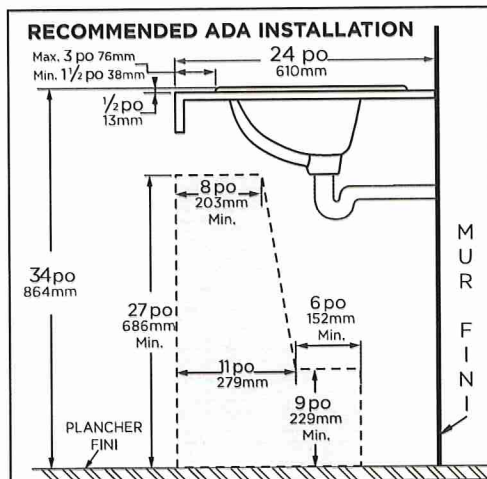

REMARQUE : Toutes les dimensions sont en pouces et millimètres. Il se peut que les illustrations ne soient pas dessinées à l'échelle.

IMPORTANT :

Les dimensions des appareils sanitaires sont nominales et peuvent varier dans les limites établies par la norme ASME A112.19.2/CSA B45.1

GERBER**MAXWELL®**
Lavabo empotrado**Características****G0012831CH / G0012834CH / G0012838CH**

- Porcelana Vítrea
- Lavabo empotrado
- Cumple con ADA
- Orificio frontal de desbordamiento
- Diseño ovalado con lavabo curvo
- Grifo y desagüe no incluidos

Technical Information:

Lavabo	G0012831CH	G0012834CH	G0012838CH
Configuración	Un Orificio	4" entre Centros	8" entre centros
Alto	8 1/8"		
Ancho	20 5/8"		
Largo	17 3/4"		
Interior del bañín	15 7/8" x 11 1/8"		
Peso Epacado	8.39 Kgs		

Accesorios que se comprarán por separado:

No Aplica

Colores disponibles:

- Blanco
- Otro: consulte el libro de precios para obtener colores adicionales / acabados

Garantía:

- Vida útil limitada en porcelana vítrea, consulte el sitio web para obtener más detalles.



Imagen de G0012834CH

2109681

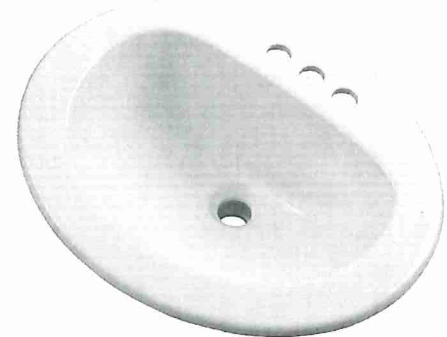
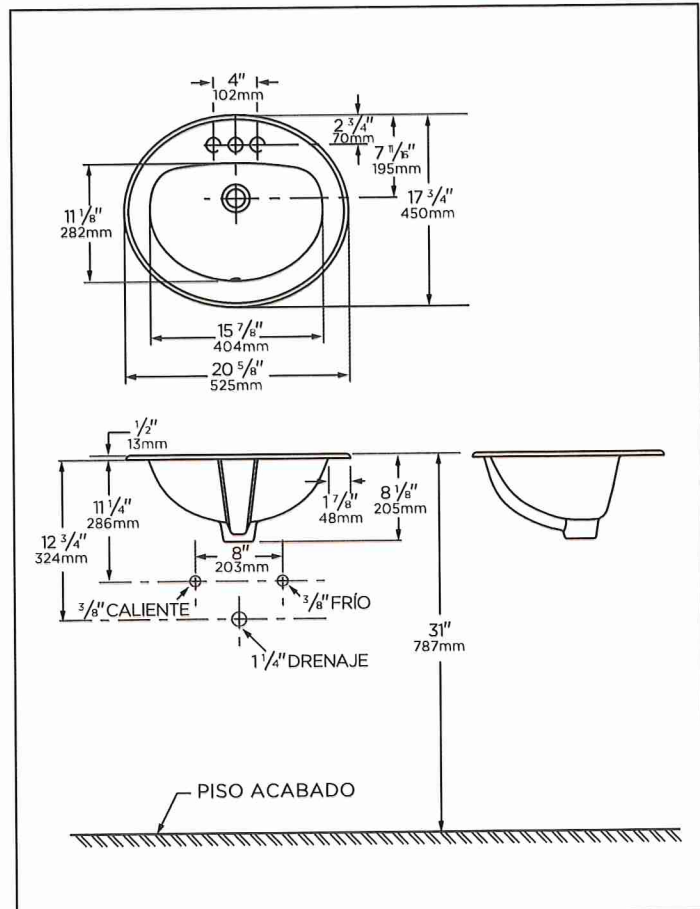
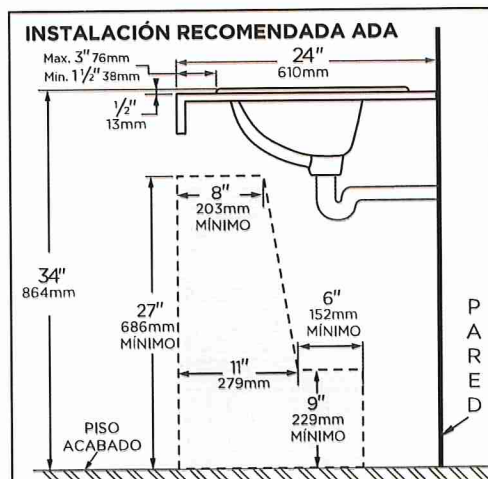

NOTAS: Todas las dimensiones están en pulgadas y milímetros. Las ilustraciones pueden no estar dibujadas a escala.

IMPORTANTE:

Las dimensiones de los accesorios son nominales y pueden variar dentro del rango de tolerancias establecido por la norma ASME A112.19.2/CSA B45.1

Debido a que estamos comprometidos con la mejora continua del producto, las especificaciones están sujetas a cambios sin previo aviso.

© 2020 Gerber Plumbing Fixtures LLC. Todos los derechos reservados gerber-us.com gerber-ca.com

07/



The
Plumbing
WAREHOUSE

LWR

Near Zero Radius Single Bowl Kitchen Sink

Product Specifications

Features

- 16 Gauge
- Type 304 Stainless Steel
- Includes Mounting Clips
- Fully Undercoated
- Sound Absorption Pads
- Brushed Satin Finish

Overall Size: 32" x 18-7/8"

Bowl Depth: 10"

Minimum Cabinet Size: 36"

Drain Opening: 3-1/2"

Drain Placement: Center Rear

USE SINK AS CUTOUT TEMPLATE

LUXART®

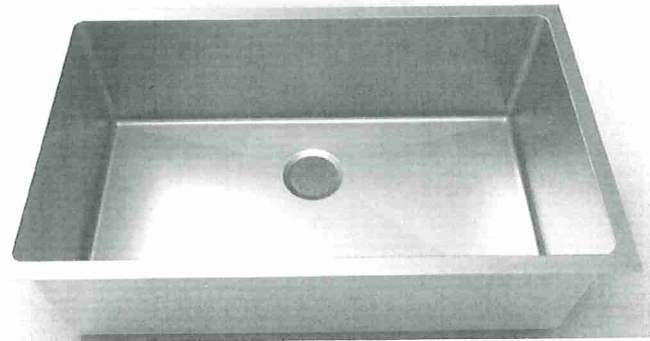

4339208

LXNZS3219

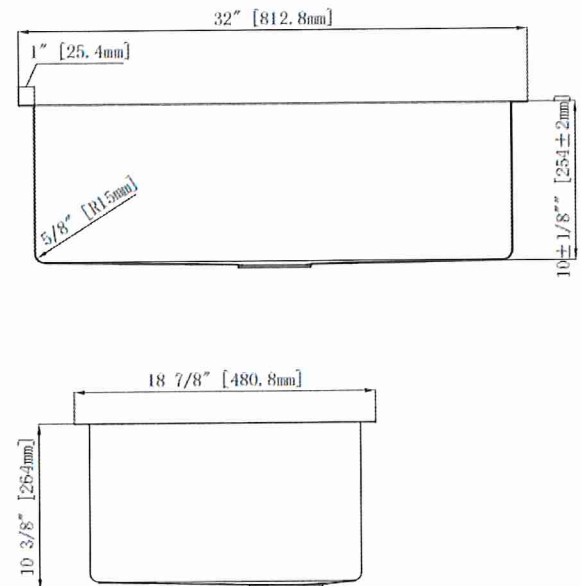
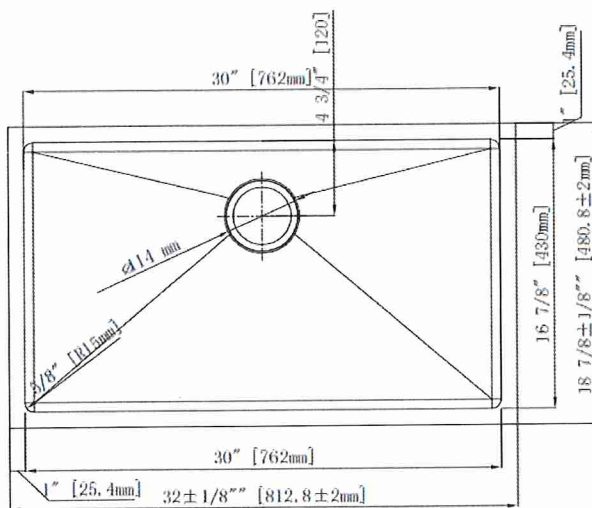

Optional Accessories

- Bottom Basin Rack: LXZS3219BG
- Basket Strainer: MLL7, ML18, ML14, ML15
- Soap Dispenser: CSD, LCSD, LGLSD

For cutout measurement: Use sink in sink box.

All dimensions listed are nominal. Luxart® reserves the right to make product and material changes at any time without notice.



Contact your sales representative for more information or visit our website at luxartcollection.com

Revised 3/13/2020

LER

KOHLER®

Highcliff™ Ultra

Top spud flushometer bowl

K-96057

Features

- Elongated bowl offers added room and comfort
- 1-1/2" (38 mm) top spud
- 2-1/8" (54 mm) fully glazed trapway
- 10" x 7" (254 mm x 178 mm) water surface
- 1.0 gpf (3.8 lpf), 1.1 gpf (4.2 lpf), 1.28 (4.8 lpf), or 1.6 gpf (6.0 lpf) depending on flushometer specified
- Also available with antimicrobial finish K-96057-SS
- 10" or 12" (254 or 305 mm) rough-in
- Supports static load of 2,500 lbs

Material

- Vitreous china

Technology

- Designed to outperform competitors in bowl cleanliness and plug resistance
- Maximum waste removal
- Engineered for toilet seat cover removal
- Excellent bowl rinse
- Engineered to flush effectively in buildings with low supply pressure and flow
- Maximum drain line carry at all flush volumes per ASME standard

Installation

- Replaces Highcrest K-4302, Highcliff K-4368 and Highline K-4405. Height and footprint may vary

**ADA****CSA B651****OBC****Codes/Standards**



ASME A112.19.2/CSA B45.1
 DOE - Energy Policy Act 1992
 EPA WaterSense®
 California Energy Commission (CEC)
 ADA
 ICC/ANSI A117.1
 CSA B651
 OBC
 IAPMO Certification

KOHLER® One-Year Limited Warranty

See website for detailed warranty information.

Available Colors/Finishes

Color tiles intended for reference only.

Color	Code	Description
	0	White
	96	Biscuit
	7	Black Black™

3811129

1-800-4KOHLER (1-800-456-4537)

Kohler Co. reserves the right to make revisions without notice to product specifications.

For the most current Specification Sheet, go to www.kohler.com USA or www.kohler.ca Canada

7-3-2024 20:24 - US

THE BOLD LOOK
 OF **KOHLER** The Plumbing WAREHOUSE
 LER

KOHLER[®]

Highcliff™ Ultra

Top spud flushometer bowl

K-96057

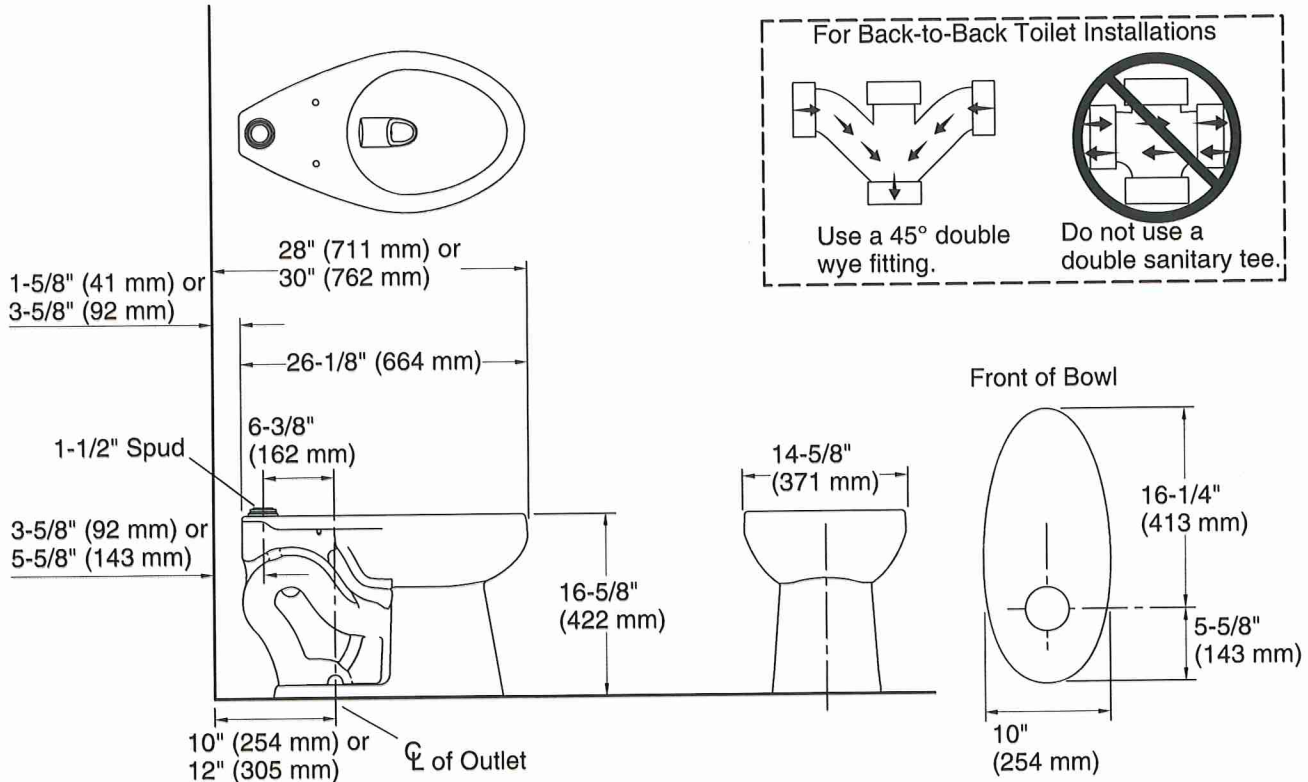

3811129

Technical Information

All product dimensions are nominal.

Toilet type:	Floor-mount
Waste Outlet:	Floor
Bowl shape:	Elongated
Flush type:	Flushometer valve siphon
Spud size:	1 1/2, Inlet, Top
Trap passageway:	2-1/8" (54 mm)
Water surface size:	10" x 7" (254 mm x 178 mm)
Rim to water surface:	6" (152 mm)
Rough-in:	12" (305 mm)
Seat-mounting holes:	5-1/2" (140 mm)

Fixture Supply Requirements

Min static pressure:	35 psi (241.3 kPa)
Max static pressure:	80 psi (551.6 kPa)
Min flowing pressure:	25 psi (172.4 kPa)

Min flow rate: 0.5 gpm (0.4 lpm)

1-800-4KOHLER (1-800-456-4537)

Kohler Co. reserves the right to make revisions without notice to product specifications.

For the most current Specification Sheet, go to www.kohler.com USA or www.kohler.ca Canada

7-3-2024 20:24 - US

Notes

Install this product according to the installation instructions.

For back-to-back toilet installations: Use only a 45° double wye fitting.

ADA, OBC, CSA B651 compliant when installed to the specific requirements of these regulations.

Plumbing codes may require elongated toilets and elongated, open-front seats in public bathrooms.

Accessibility standards may require controls to be located on the open side of the toilet.

THE BOLD LOOK
OF **KOHLER**

The
Plumbing
WAREHOUSE

WER

**REGAL® MANUAL FLUSHOMETER
REGAL 111-1.6-XL**
CODE NUMBER

3080053

DESCRIPTION

1.6 gpf, XL Sweat Solder Adapter Kit, Polished Chrome Finish, Fixture Connection Top Spud, Single Flush, Regal® Exposed Manual Water Closet Flushometer.

DETAILS

- Flush Volume: 1.6 gpf (6.0 Lpf)
- Finish: Polished Chrome (CP)
- Valve: Diaphragm
- Valve Body Material: Semi-red Brass
- Fixture Type: Water Closet
- Fixture Connection: Top Spud
- Rough-In Dimension: 11 ½" (292mm)
- Spud Coupling: 1 ½" (38mm)
- Supply Pipe: 1" (25mm)
- Adapter: XL Sweat Solder Adapter Kit (XL)

FEATURES

- ADA Compliant Metal Oscillating Non-Hold-Open Handle
- 1" I.P.S. Screwdriver Bak-Chek® Angle Stop
- Control Stop Plug
- Sweat Solder Adapter with Cover Tube
- Cast Wall Flange with Set Screw
- Vacuum Breaker Flush Connection
- Non-Hold-Open Handle and No External Volume Adjustment to Ensure Water Conservation

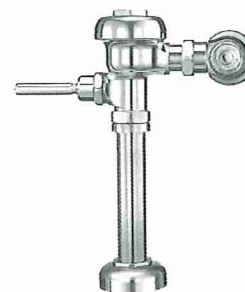
**COMPLIANCES & CERTIFICATIONS**

(ADA Compliant, BAA Compliant, BABAA Compliant, cUPC Certified, Made in the USA)

RECOMMENDED SPECIFICATION

Valve Body, Cover, Tailpiece and Control Stop shall be in conformance with ASTM Alloy Classification for Semi- Red Brass. Valve shall be in compliance with the applicable sections of ASSE 1037 and ANSI/ASME 112.19.2.

VALVE OPERATING PRESSURE (FLOWING)

15–80 PSI (103–552 kPa). Specific fixtures may require greater minimum flowing pressure - consult manufacturer requirements.

DOWNLOADS

- [Regal XL Exposed Installation Instructions](#)
- [Control Stop Repair and Maintenance Guide](#)
- [Flush Connections Flanges Repair and Maintenance Guide](#)
- [Tail Piece Repair and Maintenance Guide](#)
- [Regal Flushometers Repair and Maintenance Guide](#)
- [Flushometer Pressure gauges](#)
- [Additional Downloads](#)

NOTES

All information contained within this document subject to change without notice.

Looking for other variations of the REGAL 111 product? [View the general spec sheet with all options.](#)

WARRANTY

[View Warranty Information](#)

Sloan 10500 Seymour Ave, Franklin Park, IL 60131
Phone: 800.982.5839 • Fax: 800.447.8329 • [sloan.com](#)



REGAL® MANUAL FLUSHOMETER
REGAL 111-1.6-XL

ROUGH-IN

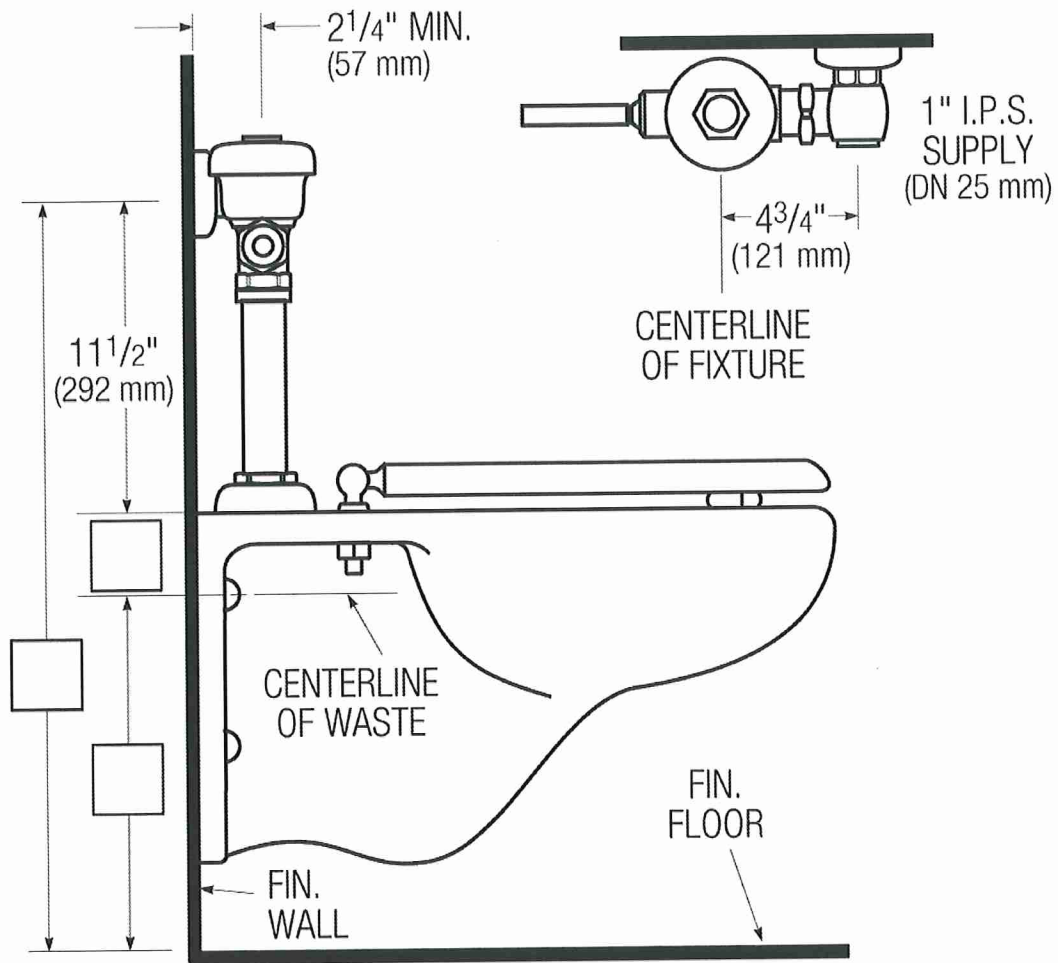

220738

Sloan 10500 Seymour Ave, Franklin Park, IL 60131
Phone: 800.982.5839 • Fax: 800.447.8329 • sloan.com

4" Centerset Lavatory Faucet

Robinet de lavabo monopièce, entraxe de 4 po
Grifo para lavabo, distancia de 4"

Product Specifications



MAINLINE®



Chelmsford™

CH211-CP

FEATURES

- Metal Lever Handle
- Fits 4" Center Holes
- Washerless Cartridge
- Lead Free* Polymer Lined Waterways
- Less Pop-up Hole
- Water Saving Aerator
- Max Flow Rate: 1.2 GPM @ 60 PSI
- 100% Factory Pressure Tested

CARACTÉRISTIQUES

- Levier en métal
- Pour robinet à entraxe 4 po
- Cartouche sans rondelle
- Tuyaux à revêtement intérieur en polymère sans plomb*
- Sans trou pour vidange mécanique
- Brise-jet économiseur d'eau
- Débit maximum: 1,2 gal/min à 60 lb/po²
- Pression vérifiée en usine- 100%

CARACTERÍSTICAS

- Manija de palanca de metal
- Se adapta a los orificios centrales de 4"
- Cartucho sin arandela
- Conductos de agua revestidos de polímero sin plomo*
- Sin orificio para ensamblaje del desagüe levadizo
- Aireador para ahorrar agua
- Flujo máximo: 1,2 GPM @ 60 PSI
- Probado en fábrica bajo presión al 100%

APPLICABLE STANDARDS/CODES

Specified model meets or exceeds the following:

NORMES ET CODES APPLICABLES

Le modèle spécifié est conforme aux normes suivantes ou les dépasse:

NORMAS Y ESTÁNDARES APLICABLES

El modelo especificado reúne o sobrepasa las siguientes condiciones

- EPA WaterSense
- ASME A112.18.1/CSA B125.1
- IAPMO/cUPC
- NSF/ANSI 372
- NSF/ANSI 61 – Sec. 9: Q≤1
- ADA*
- ≤.25% Pb

AVAILABLE FINISHES / FINIS OFFERTS / DISTINTOS ACABADOS:

- Polished Chrome / Chrome poli / Cromo lustrado (CP)



Contact your sales representative for more information or visit our website at mainlinecollection.com



MAINLINE®

4" Centerset Lavatory Faucet

Robinet de lavabo monopièce, entraxe de 4 po
Grifo para lavabo, distancia de 4"

Product Specifications

Chelmsford™
CH211-CP

4893232

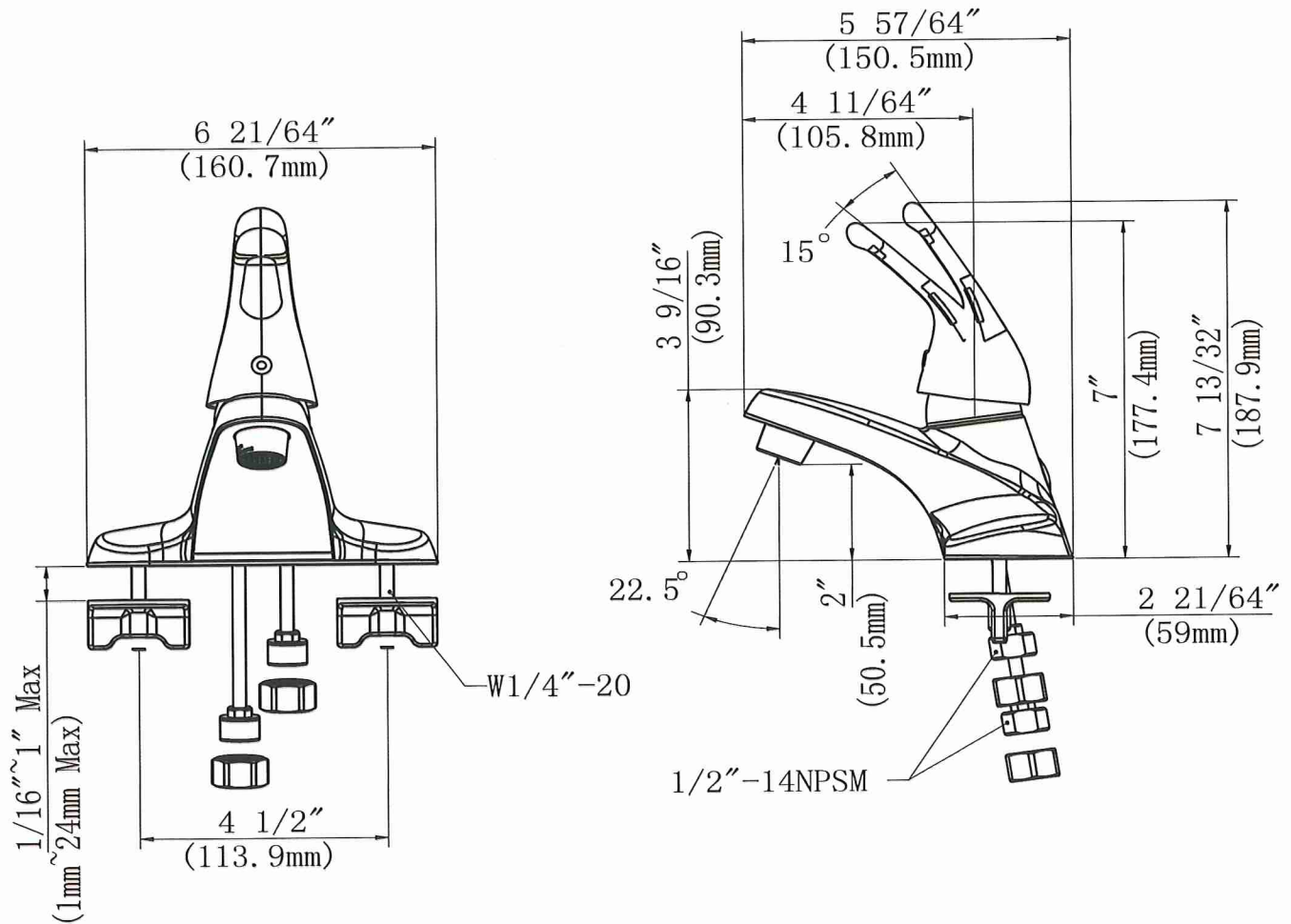

Contact your sales representative for more information or visit our website at mainlinecollection.com



Z1996-24 MOP SERVICE BASIN 24 x 24 [610 x 610]

TAG _____

Dimensional Data (inches and [mm]) are Subject to Manufacturing Tolerances and Change Without Notice

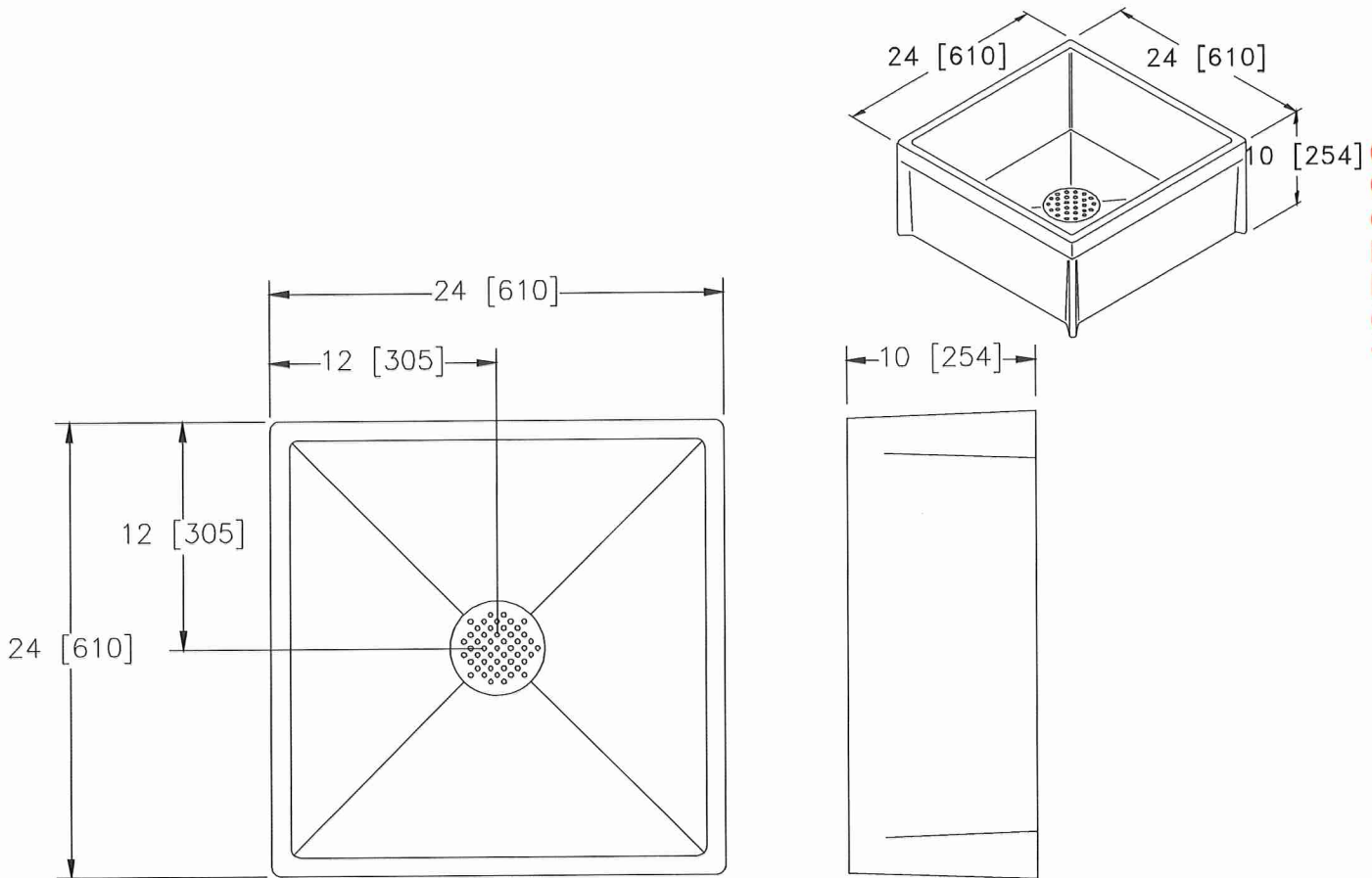

1255862

Product	Mop Basin Size	Approx. Wt. Lbs. [kg]
__ Z1996-24	24 x 24 x 10 [610 x 610 x 254]	50 [23]

ENGINEERING SPECIFICATION: Z1996-24

Mop Service Basin 24 x 24 x 10 [610 x 610 x 254] Molded high density composite basin, PVC drain body, stainless steel strainer and 3 [76] gasketed outlet connection. Certifications: Meets ANSI Z124.6, CSA listed, and IAPMO listed under file # 3561.

OPTIONS (Check/specify appropriate options)

SUFFIXES

- ___ -AW White Body
- ___ -BS Stainless Steel Bumper Guard
- ___ -BV Vinyl Bumper Guard
- ___ -HH Hose and Hose Bracket
- ___ -MH Mop Hanger
- ___ -NHG PVC Drain Gasket for No-Hub Pipe
- ___ -PRP Pipe Reducer for PVC Drain
- ___ -PRS Pipe Reducer for Stainless Steel Drain
- ___ -SDL Stainless Steel Drain with Dome Strainer, Lint Basket and Locking Nut
- ___ -SF Service Faucet
- ___ -WG Wall Guard #20 Gage Type 304 Stainless Steel (2 Panels-Indicate Size)



ZURN INDUSTRIES, LLC ♦ SPECIFICATION DRAINAGE OPERATION ♦ 1801 Pittsburgh Ave. ♦ Erie, PA 16514

Phone: 814455-0921 ♦ Fax: 814454-7929 ♦ World Wide Web: www.zurn.com

In Canada: ZURN INDUSTRIES LIMITED ♦ 3544 Nashua Drive ♦ Mississauga, Ontario L4V1L2 ♦ Phone: 905405-8272 Fax: 905405-129

Rev. K

Date: 03/06/13

C.N. No

Prod./Dwg. No. Z 1996-24





T&S BRASS AND BRONZE WORKS, INC.

2 Saddleback Cove / P.O. Box 1088
Travelers Rest, SC 29690

Model No.

B-0665-BSTR

Item No.

Travelers Rest, SC: 800-476-4103 • Simi Valley, CA: 800-423-0150 • Fax: 864-834-3518 • www.tsbrass.com



ADA Compliant

This Space for Architect/Engineer Approval

Job Name _____ Date _____

Model Specified _____ Quantity _____

Customer/Wholesaler _____

Contractor _____

Architect/Engineer _____

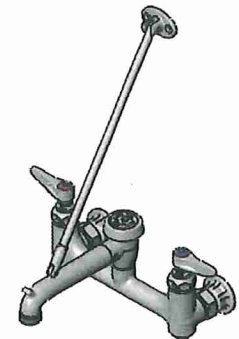
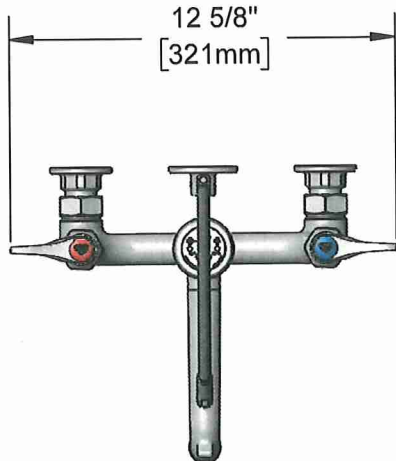

Support Rod w/
Wall Bracket &
Mounting Screws

Mounting
Surface

Items Not Shown
For Clarity

B-0969
1/2" NPT Vacuum
Breaker

Quarter-Turn
Eterna Cartridges w/
Spring Checks &
Lever Handles w/
Color Coded Indexes

Garden Hose
Male Outlet

Ø 2" [51mm]
Flanges w/
1/2" NPT
Female Inlets

Built-In Service
Stops

3 15/16"
[100mm]

14 5/16"
[364mm]

8"
[203mm]

2 11/16"
[68mm]

Adjustable From
7 3/4" to 8 1/4"
[197mm to 210mm]

9 1/8"
[232mm]

Product Specifications:

8" Wall Mount Service Sink, Quarter-Turn Eterna Cartridges w/ Spring Checks, Lever Handles, Upper Support Rod, Garden Hose Male Outlet, Built-In Service Stops, Rough Chrome Finish, 1/2" NPT Vacuum Breaker & 1/2" NPT Female Inlets

Product Compliance:

ASME A112.18.1 / CSA B125.1
NSF 61 - Section 9
NSF 372 (Low Lead Content)
ANSI A117.1 (ADA)
ASSE 1001 (VB)

686283





T&S BRASS AND BRONZE WORKS, INC.

2 Saddleback Cove / P.O. Box 1088
Travelers Rest, SC 29690

Model No.

B-0665-BSTR

Item No.

Travelers Rest, SC: 800-476-4103 • Simi Valley, CA: 800-423-0150 • Fax: 864-834-3518 • www.tsbrass.com

ITEM NO.	SALES NO.	DESCRIPTION
1	009545-25	Spout w/ Male GH Outlet & Upper Clevis - Rough Chrome
2	009546-40	Upper Support Rod
3	001193-19NS	Red Button Index, Press-in
4	B-0969	1/2" NPT Vacuum Breaker
5	002534-25	Close Nipple, 1/2" NPT
6	001638-45NS	Lever Handle (New Style)
7	002712-40NS	Quarter-Turn Eterna Cartridge w/ Spring Check, Handle, Red Index & Screw, RTC
8	012443-40NS	Quarter-Turn Eterna Cartridge w/ Spring Check, RTC
9	018506-19NS	Blue Button Index, Press-in
10	000925-45	Lab Handle Screw
11	002711-40NS	Quarter-Turn Eterna Cartridge w/ Spring Check, Handle, Blue Index & Screw, LTC
12	012442-40NS	Quarter-Turn Eterna Cartridge w/ Spring Check, LTC
13	001019-45	Coupling Nut Washer
14	00AA	1/2" NPT Female Eccentric Flange
15	163A	Built-in Service Stop

686283

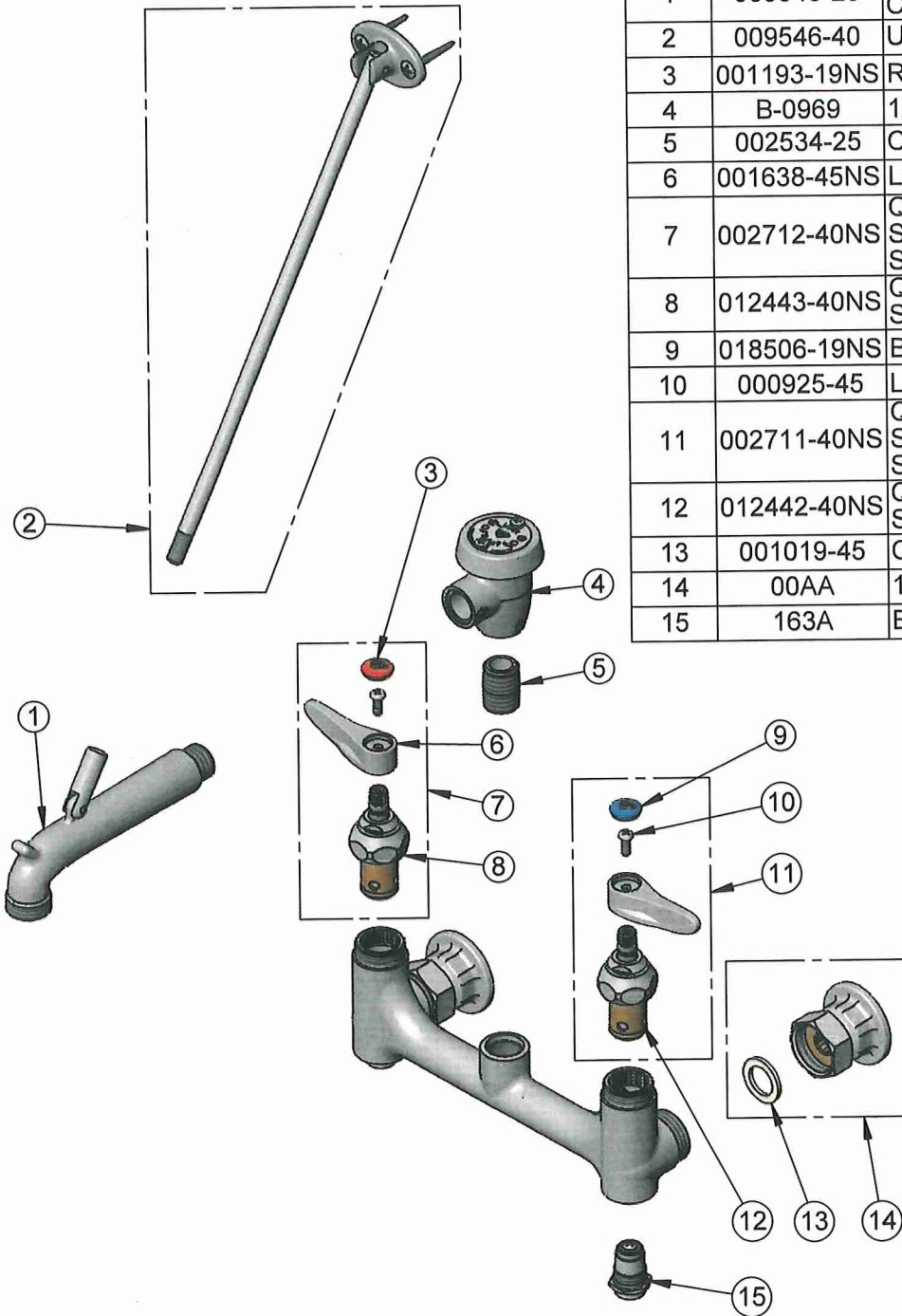

Product Specifications:

8" Wall Mount Service Sink, Quarter-Turn Eterna Cartridges w/ Spring Checks, Lever Handles, Upper Support Rod, Garden Hose Male Outlet, Built-In Service Stops, Rough Chrome Finish, 1/2" NPT Vacuum Breaker & 1/2" NPT Female Inlets

Product Compliance:

ASME A112.18.1 / CSA B125.1
NSF 61 - Section 9
NSF 372 (Low Lead Content)
ANSI A117.1 (ADA)
ASSE 1001 (VB)





The new degree of comfort.®

Professional Classic® electric water heaters are engineered for longer life – restored heating elements and premium grade anode rod

Efficiency

- .90 - .93 UEF
- Isolated tank design reduces conductive heat loss
- Restored copper upper element and restored Lifeguard™ stainless steel lower element to prolong anode rod and tank life



Performance

- FHR: 45 - 67 gallons, based on gallon capacity
- Recovery: 21 GPH at a 90° F rise

System Sentinel

(Available on selected models)

- Exclusive diagnostic system with glowing LEDs that verify heating element operation. LEDs pin point the exact location of functioning or non-functioning heating elements

Longer Life

- Premium grade anode rod provides long-lasting tank protection

Features

- Electric junction box located above heating elements for easy installation
- Over-temperature protector cuts off power in excess temperature situations
- Automatic thermostat keeps water at desired temperature

Plus...

- Rheemglas® tank lining resists corrosion and prolongs tank life
- EverKleen® self cleaning device fights harmful sediment build-up with a high-velocity spiraling water stream – helps operating efficiency by saving energy, money and improving tank life



- Enhanced-flow brass drain valve
- Temperature and pressure relief valve included
- Models are compliant to HUD Standards for manufactured housing and modular construction
- Low lead compliant

Warranty

- 6-Year limited tank and parts warranty*
- With ProtectionPlus™ the 6-year limited tank warranty becomes 10-year

*See Residential Warranty Certificate for complete information

Units meet or exceed ANSI requirements and have been tested according to the AHRI Operations Manual and D.O.E. procedures. Units meet or exceed the energy efficiency requirements of NAECA, ASHRAE standard 90, ICC Code and all state energy efficiency performance criteria.

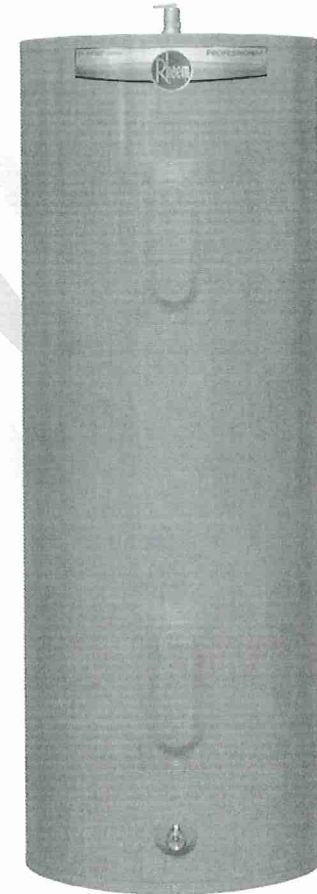

3539479

Professional Classic
19.9 to 55-Gallon Capacities
240 Volt AC/Single Phase
Double and Single Element Models
Electric



See specifications chart on back.



INTEGRATED HOME COMFORT

The
Plumbing
WAREHOUSE
ULCR



The new degree of comfort.



Professional Classic® Specifications

TYPE	DESCRIPTION			FEATURES		ROUGHING IN DIMENSIONS (SHOWN IN INCHES)				ENERGY INFO.
	NOMINAL GALLON CAPACITY	RATED GALLON CAPACITY	MODEL NUMBER	UEF FIRST HOUR RATING G.P.H.	RECOVERY IN G.P.H. 90° F RISE	TANK HEIGHT A	HEIGHT TO WATER CONN. B	DIAMETER C	APPROX. SHIP WT. (LBS.)	UNIFORM ENERGY FACTOR (UEF)
Tall	30	27	PROE30 T2 RH95 ¹	46	21	47-1/2	50-3/8	19	92	0.92
Tall	40	36	PROE40 T2 RH95 ¹	55	21	60-3/4	63-5/8	19-1/4	109	0.93
Tall	50	45	PROE50 T2 RH95 ¹	63	21	58-5/8	61-5/8	20-1/4	121	0.93
Tall	55	55	PROE55 T2 RH94 ¹	72	21	57	59-3/4	22-1/4	128	0.92
Med.	30	27	PROE30 M2 RH95 ¹	45	21	37-1/2	40-1/2	20-1/4	92	0.90
Med.	40	36	PROE40 M2 RH95 ¹	55	21	48-1/4	50-1/2	20-1/4	106	0.93
Med.	50	45	PROE50 M2 RH95 ¹	62	21	48	50-1/2	23	132	0.93
Short	19.9	-	PROE20 S2 RH	-	21	31-1/2	31-1/2	17	62	-
Short	28	25	PROE28 S2 RH95	45	21	30	31-1/8	23	95	0.92
Short	30	27	PROE30 S2 RH95 B**	46	21	30-1/8	32	19-3/4	95	0.92
Short	36	33	PROE36 S2 RH95	46	21	31-1/2	33	24-1/4	118	0.92
Short	38	35	PROE38 S2 RH95 B**	51	21	31-1/2	32-5/8	23	108	0.92
Short	47	43	PROE47 S2 RH95	54	21	32	34	26-1/4	149	0.93

Uniform Energy Factor and rated gallon capacity based on Department of Energy (DOE) requirements.

¹ System Sentinel optional. Add EC1 to the end of the model number. System Sentinel not available on single element models, available on dual element models only. System Sentinel not available in excess of 5 kW on 208 V models.

** Insulation blanket required to achieve UEF value. Water heater dimensions prior to installing insulation blanket. Blanket is included with water heater.

- Heaters furnished with standard 240 volt AC, single phase non-simultaneous wiring, and 4500 watt upper and lower heating elements.
- If heating elements of different wattages than those shown are demanded by zone requirements, they must be specifically requested.
- Single element models available on special order (6000W max.). Substitute "1" for "2" in model number.
- Special Wiring Options – A limited number of special wiring options are available. Consult factory for price and availability.
- All models equipped with heat traps.

Recovery = wattage / 2.42 x temp. rise °F.
 Example: $\frac{4500W}{2.42 \times 90^\circ} = 21 \text{ GPH}$

Recovery calculations used are based on 4500 watt elements used in non-simultaneous operation.

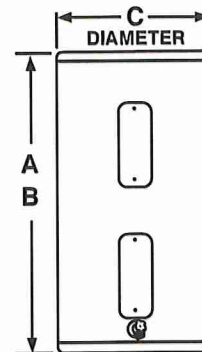
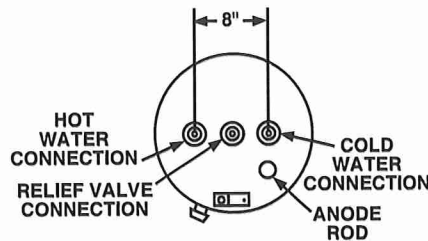

WATER CONNECTIONS ALL 3/4" N.P.T.

3539479

In keeping with its policy of continuous progress and product improvement, Rheem reserves the right to make changes without notice.

Rheem Water Heating • 1115 Northmeadow Parkway, Suite 100
 Roswell, Georgia 30076 • www.rheem.com



INTEGRATED HOME COMFORT





MAINLINE

Plastic Commercial Elongated Toilet Seat

Product Specifications

Description

Open front less cover, elongated, heavy-duty, injection molded solid plastic toilet seat. Features two molded-in bumpers, non self-sustaining (1055), or self-sustaining (1055SSC), check hinges with non-corrosive 300 Series stainless steel posts, pintles and hardware. This seat complies with American National Standard Z124.5 Toilet (Water Closet) Seats as a class Commercial Heavy Duty.

Model: ML1055 / ML1055SSC

Specifications	
Size:	Elongated
Weight:	2.9 lbs
Color:	White (000)
Material:	Plastic
Style:	Open Front less Cover
Bumpers:	Two
Hinges:	Plastic Non Self-Sustaining (1055), or Self-Sustaining (1055SSC), with 300 Series Stainless Steel Posts and Pintles
Fastening System:	Non-Corrosive 300 Series Stainless Steel Hardware



2968074

ML1055



PLASTIC HINGES WITH STAINLESS STEEL POSTS AND PINTLES

ML1055SSC

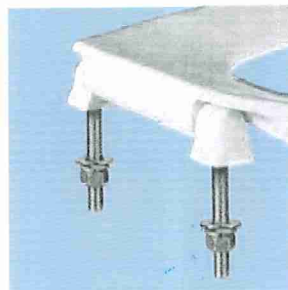

NON-CORROSIVE STAINLESS STEEL HARDWARE

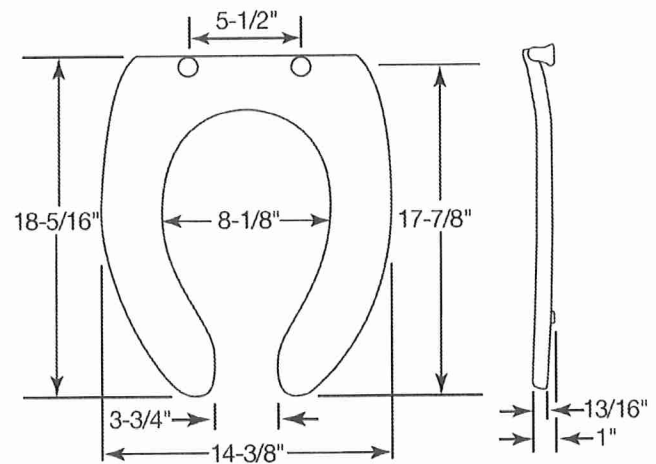

Warranty

See warranty information for more details.

All dimensions listed are nominal. MAINLINE® reserves the right to make product and material changes at any time without notice.



Complies with IAPMO/ANSI Z124.5 Performance Standards Heavy-Duty Commercial



Contact your sales representative for more information or visit our website at mainlinecollection.com





SPECIFICATION SHEET

Thermal Expansion Tanks

- Carbon steel shell
- Stainless steel system connection
- Heavy duty butyl rubber diaphragm
- FDA Grade polypropylene liner
- 35 PSI Factory pre-set pressure
- Max working pressure 150 PSI
- Max working temperature 200°

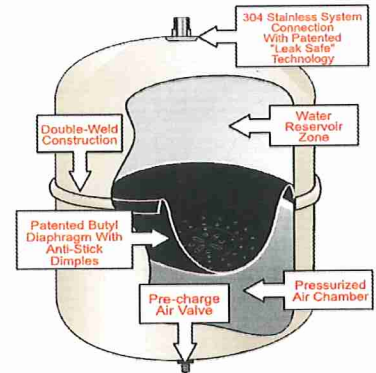

3606810

TANK QUICK SIZING GUIDE

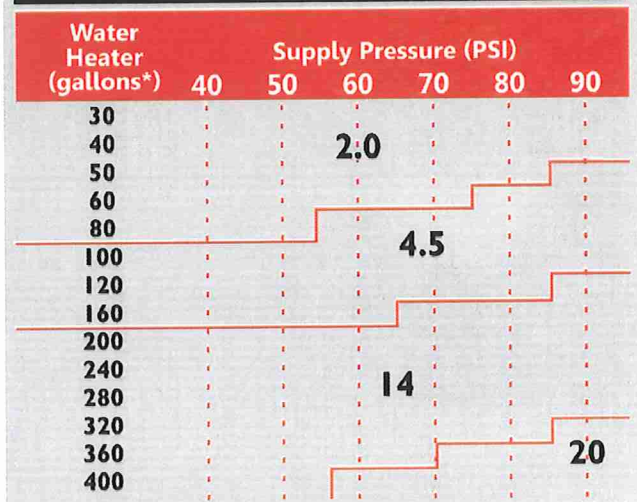

ITEM #	VOLUME (GAL.)	ACCEPTANCE VOLUME GALLONS	HEIGHT	DIAMETER	SYS. CONN.	WT. (LBS.)
HPTET2	2.1	1.2	12-1/2"	8"	3/4"	4.7
HPTET45	4.5	3.5	15"	11"	3/4"	8
HPTET10	10	5.2	20"	11-1/2"	3/4"	13.5

HYDRAPRO INC.

Phone: 877-813-2333; Fax 877-249-8435

Atlanta - Boston - Dallas - Houston - Philadelphia - Pompano Beach

www.hydrapro.biz





**Dearborn®
Brass**

4675 W. 160th St.
Cleveland, Ohio 44135
Ph: (800) 321-9532
Fax: (800) 321-9535
www.dearbornbrass.com

SUBMITTAL SPECIFICATION

**CAST GRID
PATENT OUTLET PLUG**

Engineering Specification: Dearborn Brass Semi-Cast Grid Patent Overflow Plug with 1-1/4" x 6" – 17 gauge tailpiece.

Job Reference

DESCRIPTION

- Chrome Finished
- Includes: Cast Grid, P.O. Plug with nuts and washers and 17 gauge tailpiece
- Designed for installation in most commercial applications
- cUPC Listed

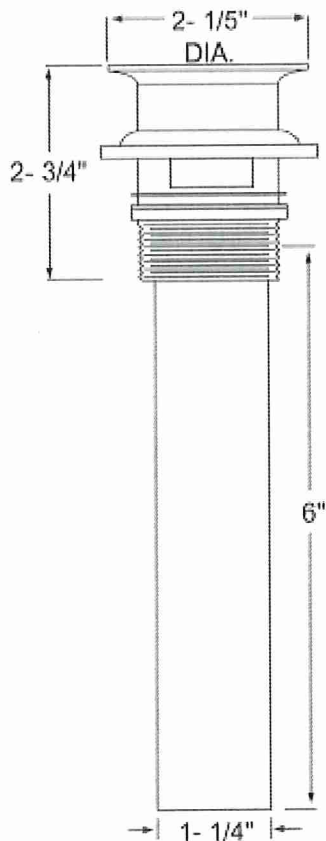
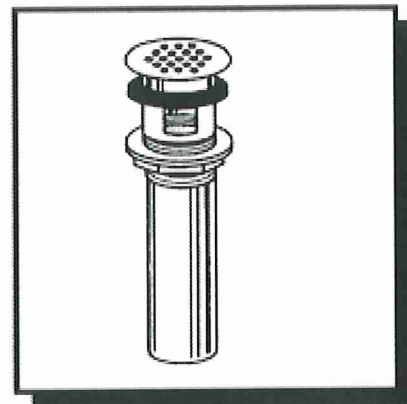

✓	Product No.	Description	Carton Quantity	Carton Weight (lbs)
	760-1	Semi-Cast Grid Patent Overflow Plug with 1-1/4" x 6" – 17 gauge Tailpiece	25	18

Data is subject to manufacturing tolerances.

1043731



**Dearborn®
Brass**

4675 W. 160th St.
Cleveland, Ohio 44135
Ph: (800) 321-9532
Fax: (800) 321-9535
www.dearbornbrass.com

SUBMITTAL SPECIFICATION

**BRASS TUBULAR
1-½" TRAP PRIMER TAILPIECE**

Engineering Specification: Dearborn Brass 1-½" Brass Tubular Trap Primer Tailpiece allows connection from tailpiece to supply route for water to travel to drain trap.

Job Reference

DESCRIPTION

- Chrome Finish
- 17 Gauge Brass
- Brass Slip Nut
- cUPC Listed

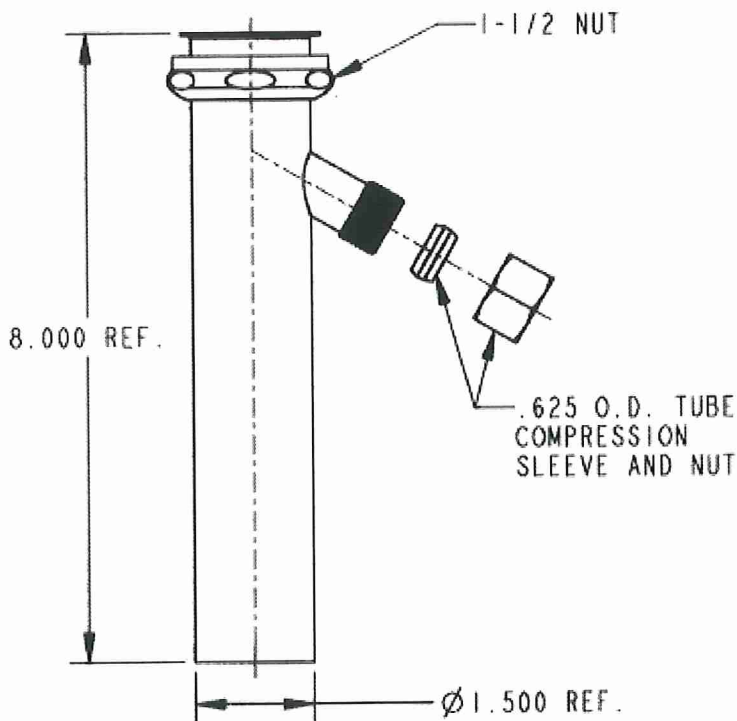
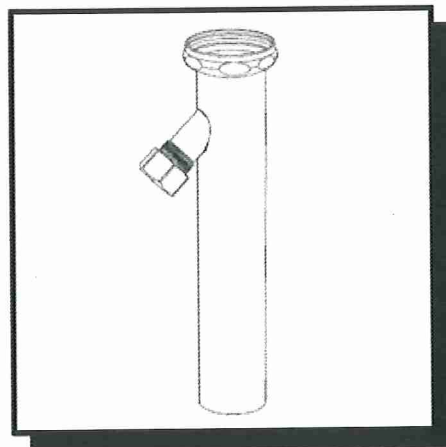

✓	Product No.	Description	Carton Quantity	Carton Weight (lbs)
	832-1	1-½" Trap Primer Tailpiece	10	9

Data is subject to manufacturing tolerances.

775122

Pull-down Kitchen Faucet

Robinet de cuisine à bec arroseur

Grifo extraíble de cocina

Product Specifications



MAINLINE



Lisburn™

LB137F3-CP
LB137F3-BN
LB137F3-ORB

FEATURES

- Three Function Spray: Stream Spray, Full Spray, Blade Spray
- Metal Lever Handle
- Ceramic Disc Cartridge
- Lead Free* Brass Waterways
- Includes Optional Deck Plate, Check Valve and Quick Connector
- Water Saving Aerator
- Max Flow Rate: 1.8 GPM @ 60 PSI
- 100% Factory Pressure Tested

CARACTÉRISTIQUES

- Jet à trois fonctions : flux, plein, lame
- Levier en métal
- Cartouche disque céramique
- Tuyaux en laiton sans plomb*
- Comprend une plaque de pont optionnelle, une soupape de retenue et un connecteur rapide
- Brise-jet économiseur d'eau
- Débit maximum: 1,8 gal/min à 60 lb/po²
- Pression vérifiée en usine- 100%

CARACTERÍSTICAS

- Spray de tres funciones: Spray de corriente, Spray completo, Spray de cuchilla
- Manija de palanca de metal
- Cartucho de disco cerámico
- Conductos de agua de bronce sin plomo*
- Incluye placa de cubierta opcional, válvula de retención y conector rápido
- Aireador para ahorrar agua
- Flujo máximo: 1,8 GPM @ 60 PSI
- Probado en fábrica bajo presión al 100%

APPLICABLE STANDARDS/CODES

Specified model meets or exceeds the following:

NORMES ET CODES APPLICABLES

Le modèle spécifié est conforme aux normes suivantes ou les dépasse:

NORMAS Y ESTÁNDARES APLICABLES

El modelo especificado reúne o sobrepasa las siguientes condiciones

- ASME A112.18.1/CSA B125.1
- IAPMO/cUPC
- NSF/ANSI 372
- NSF/ANSI/CAN 61 – Sec. 9: Q≤1
- ADA
- *≤ .25% Pb

AVAILABLE FINISHES / FINIS OFFERTS / DISTINTOS ACABADOS:

- Polished Chrome / Chrome poli / Cromo lustrado (CP)
- PVD Brushed Nickel / PVD Nickel brossé / PVD Níquel cepillado (BN)
- Oil Rubbed Bronze / Bronze poncé à l'huile / Bronce lustrado al aceite (ORB)



Contact your sales representative for more information or visit our website at mainlinecollection.com

The Plumbing Warehouse
LCR

Revised 1/2012

4791344



MAINLINE®

Pull-down Kitchen Faucet

Robinet de cuisine à bec arroseur

Grifo extraíble de cocina

Product Specifications

Lisburn™

LB137F3-CP

LB137F3-BN

LB137F3-ORB

4791344

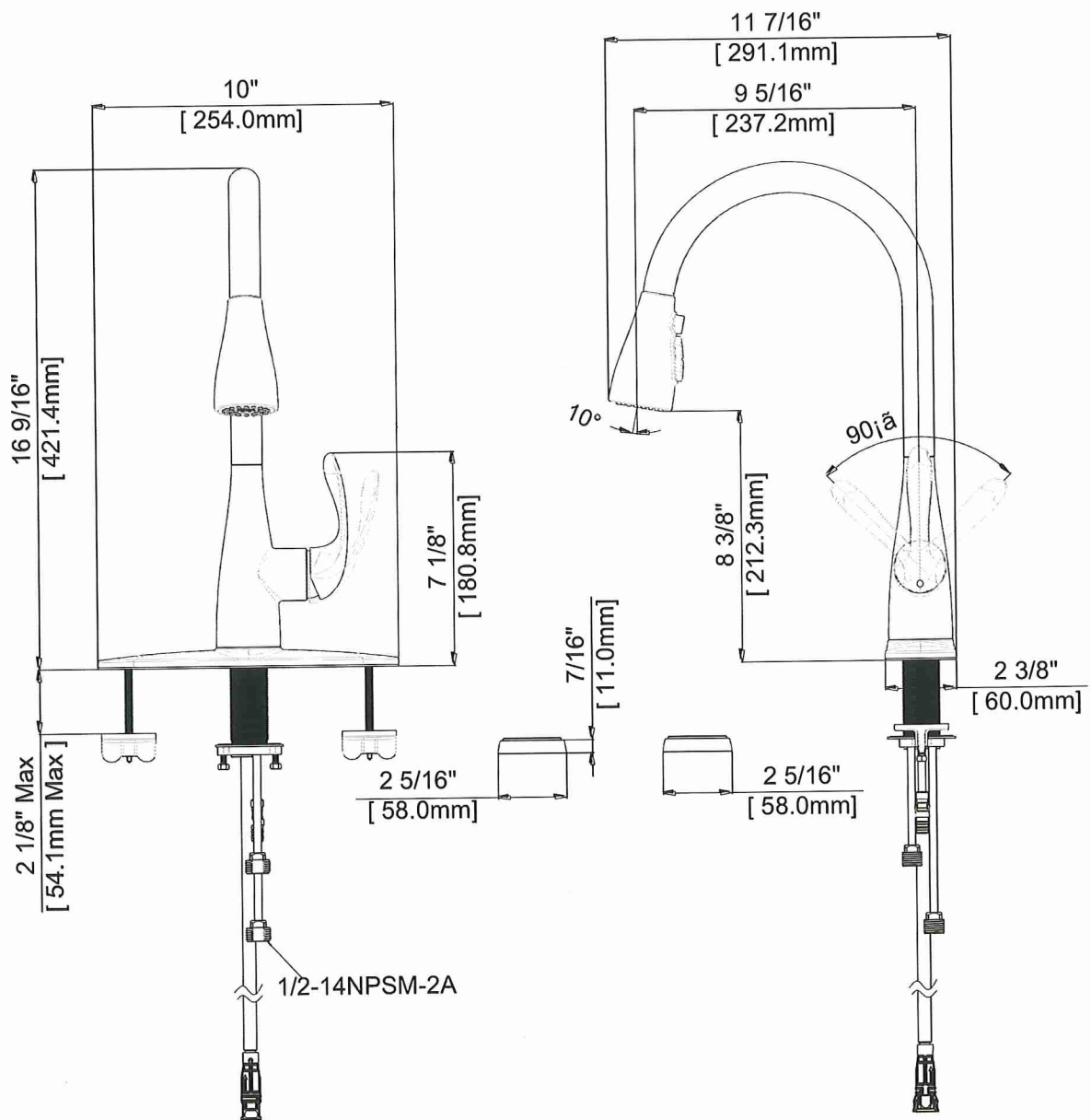

Contact your sales representative for more information or visit our website at mainlinecollection.com



Revised 1/2002

4633674

ELKAY LZS8WSLK_UCO EZH20 WTR
COOLER KIT-UNIV CNTRL OK

Spec sheet not available