

Permit Application

(Complete All Applicable Pages)

Project:	Elks Lodge #2321		
Project Type:	SEWAGE SYSTEM		
Estimated Project Cost:	80K		
Engineer:	BRIAN MISTICH		
Telephone:	985-285-4564		
Parish:	St Tammany	Nearest Town:	Sldell
Population Served:	270 PERSONS		
New System?		Existing System?	
<input checked="" type="checkbox"/>		<input checked="" type="checkbox"/> to be condemned	
Project to be Owned and Operated By: <small>(include name and address)</small>	Sldell Elks' Lodge # 2321 34212 Elk's Rd Sldell LA 70460		
Proposed Project Will Connect to: <small>(name of water and/or sewer system)</small>	N/A		

SEWER COLLECTION SYSTEM

Project:		ELKS LODGE #2321			
Engineer:		Brian A. Mistich			
General Scope of Project:		Sewage Treatment Plant			
GRAVITY PIPING	Material (specify ASTM standard and standard dimension ratio-SDR)	ASTM D3034, SDR 35			
	Size (8 inch minimum diameter)	4"			
	Joints and Materials of Fitting:	Glue Joints			
FORCE MAINS	Material (specify ASTM standard and standard dimension ration-SDR)	n/a			
	Size (3 inch minimum diameter <u>without</u> grinder pumps; 1 ¼ minimum diameter <u>with</u> grinder pumps)	n/a			
	Joints and Materials of Fitting:	n/a			
LAYOUT	Slope of Gravity Mains	1%Min.	1%Max.	1%Majority	
	Location with Respect to Water Lines:	Maintain 18" Minimum Vertical Clearance @ Crossings?	<input checked="" type="checkbox"/> Yes <input type="checkbox"/> No		
		Maintain 6' Minimum Horizontal Clearance?	<input checked="" type="checkbox"/> Yes <input type="checkbox"/> No		
	Maximum Distance Between Manholes:	n/a			
	Number of Surface Water Crossings/Encounters:	n/a			
	Other Comments: (Manhole Construction, Highway Crossing, etc.)				
Deflection Testing?		Hydrostatic Testing?			
<input type="checkbox"/> Yes <input type="checkbox"/> No		<input type="checkbox"/> Yes <input type="checkbox"/> No			
NAME OF CERTIFIED OPERATOR:		GRETCHEN LANDRY #57072			

EXTENDED AERATION SEWAGE TREATMENT FACILITY

1 of 3

Project:	Elks' Lodge #2321			Water Well within 100'?
Engineer:				
General Scope of Project:	Sewer treatment plant by EJ Breaux Contractors LLC			<input type="checkbox"/> Yes <input checked="" type="checkbox"/> No
Design Average Flow:	5000 GPD			
BOD ₅ Loading (in lbs of BOD ₅ per day):				
Max. # of Lots or Population at Maximum Capacity:				
Initial # of Lots (or population):				
Industrial Waste:	N/A			
Design Effluent Limits:	BOD ₅ : 24 mg/L MO AVG	TSS: 30 mg/L MO AVG	NH ₃ N: 05	
RECEIVING STREAM: (provide complete path from outfall to first perennial non-intermittent waterway in the path of the projected outfall.)	Parish drainage ditch Bayou Liberty			
Plant Manufacturer:	EJ Breaux Contractors, LLC			
Plant Model #:	EJBC5.0			
Materials of Construction:	Concrete			
AERATION TANK	Volume:	5,000 gallons		
	Retention Time (24 Hour Min):	24		
	BOD ₅ Loading: (lb per 1000 CF, 12.5 max.)	8.35		
	Screen or Communitor?	<input type="checkbox"/> Yes <input checked="" type="checkbox"/> No		
FINAL CLARIFIER	Surface Area:	35.65		
	Surface Loading: (extended aeration plants 1000 gpd/ft ² @ peak hourly flow max loading)	137		
	Volume:	840		
	Scum Baffle:	Yes		
	Skimmer Through:	Yes		
	Weir Length (ft):	5'6"		
	Weir Loading: (at peak hourly flow Plant ≤ 1mgd has 20,000 gpd/ft max load Plant > 1mgd has 30,000 gpd/ft max load)	455		
NAME OF CERTIFIED OPERATOR:	GRETCHEN CANDRY #57072			

EXTENDED AERATION SEWAGE TREATMENT FACILITY

2 of 3

AIR SUPPLY	# of Blowers (2 minimum):	2		
	Capacity of Each (SCFM):	36		
SLUDGE RETURN	Method:	Air Lift		
	Maximum Flow (GPM):	5.2 GPM		
	Maximum Percent (% of DAF):	150%		
SLUDGE DRYING BEDS	Number of Beds:	N/A		
	Area of Each Bed:	N/A		
	Total Area:	N/A		
	Area per Capita:	N/A		
	Gravel Layer Depth:	N/A		
	Sizes:	N/A		
	Sand Depth:	N/A		
	Under-drain Size:	N/A		
	Freeboard Above Sand:	N/A	Splash Plate? <input type="checkbox"/> Yes <input type="checkbox"/> No	
	Effluent To:	N/A		
SLUDGE LAGOONS	Number of Lagoons:	N/A		
	Maximum Depth:	N/A		
	Free Board:	N/A		
	Volume of Each Lagoon:	N/A		
	Volume of Each Lagoon per Capita:	N/A		
	Pump:	N/A		
	Piping Material:	N/A	Size: N/A	
	Effluent To:	N/A		
OTHER SLUDGE DISPOSAL METHODS Explain:	Will haul off as needed according to state law.			

EXTENDED AERATION SEWAGE TREATMENT FACILITY

3 of 3

CHLORINATION	Number:		2		
	Gas or Hypo:		hypo		
	Capacity (lb per 24 hrs):		.33		
	Test Kit:		Not applicable		
	Location:		inline		
	Ventilation:		open grating top		
CHLORINE CONTACT CHAMBER	Inside Dimensions	Length:	60"		
		Width:	36"		
		Operating Depth:	20"		
	Capacity (gal):		220		
	Retention Time: (15 minute minimum @ peak hourly flow or maximum rate of pumping)		32 min		
	Over-and-Under or End-Around Baffles? <input type="checkbox"/> Yes <input checked="" type="checkbox"/> No			Scum Baffles? <input type="checkbox"/> Yes <input checked="" type="checkbox"/> No	
ADDITIONAL DETATILS	Power Supply (Dual)? <input type="checkbox"/> Yes <input checked="" type="checkbox"/> No		Washdown Facility? <input checked="" type="checkbox"/> Yes <input type="checkbox"/> No		
	Facility Fenced? <input checked="" type="checkbox"/> Yes <input type="checkbox"/> No		Gates Locked? <input checked="" type="checkbox"/> Yes <input type="checkbox"/> No		
		Backflow Prevention? <input checked="" type="checkbox"/> Yes <input type="checkbox"/> No Type: BWV			
		Access Road? <input type="checkbox"/> Yes <input checked="" type="checkbox"/> No			
Copy of DEQ Administrative Completeness Determination Letter and Response to Request for Preliminary Determination or Discharge Permit attached? <input checked="" type="checkbox"/> Yes <input type="checkbox"/> No					
ADDITIONAL COMMENTS					
LOCATIONAL INFORMATION	Coordinates:				
	Latitude 30° 18' 03" N				
	Longitude 89° 49' 04" W				
	OR				
Latitude . ° N					
Longitude . ° W					
Geographic Datum: NAD83 <input type="checkbox"/> WGS84 <input type="checkbox"/> NAD27 <input type="checkbox"/>					
Collection Method: GPS <input type="checkbox"/> — DGPS/WAAS enabled? Yes <input type="checkbox"/> No <input type="checkbox"/> — Horizontal Accuracy? _____ meters Map <input type="checkbox"/> Specify: _____ Scale: _____					

EJB Commercial Systems
3153 Hwy 70 South, Pierre Part, LA 70339
Phone: 985-252-6183
email: ejbreaux@bellsouth.net

Concrete Sewage Treatment Systems

General

The wastewater treatment plant shall be an EJ Breaux Commercial Systems; model EJBC5.0 prefabricated concrete package plant as manufactured by EJ Breaux Commercial Systems, Pierre Part, Louisiana. The wastewater treatment system shall be of the activated sludge type specifically known as "extended aeration" designed for treating a total of 5,000 gallons per day of 210 PPM-BOD5; maximum, domestic sewage based on composite sewage samples of the average daily flow. The complete system shall include all necessary equipment for the efficient plant operation.

The system shall be factory assembled so as far as possible, with all piping and controls.

Influent Characteristics

The system shall be capable of treating 5,000 gallons per day of raw domestic sewage, having a maximum organic strength of 210 PPM (BOD5), and 210 PPM suspended solid. No substance shall be introduced in quantities, which are toxic to biological organisms. The plant shall be designed to handle average daily flow rates not to exceed 250% of the design flow.

Tank Construction

All tank vessels shall be fabricated with 4,000 PSI concrete with rebar & 6" wire mesh. All walls shall be continuous and water-tight and shall be supported by a structural reinforcing member where required.

All tank piping shall be schedule 40 galvanized steel and \ or PVC.

The system shall be transported to the job site in 4 section(s).

Influent Connection

The influent connection shall be one 4" (four inch) FNPT collar.

Aeration Chamber

There shall be an aeration chamber to work in conjunction with the clarifier chamber. The aeration chamber shall conform to the following specification: The aeration shall be of sufficient capacity to provide a minimum of 24 hours retention of the average daily flow, and/or a minimum of 5.1 cubic feet per pound of BOD5 of applied loading. The vessel shall be so shaped on each side to prevent sludge accumulation, to enhance rotation of the vessel contents, and to prevent scum and froth accumulation.

JOHN BEL EDWARDS
GOVERNOR

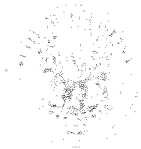

ROGER W. GINGLES
SECRETARY

State of Louisiana
DEPARTMENT OF ENVIRONMENTAL QUALITY
OFFICE OF ENVIRONMENTAL SERVICES

August 1, 2023

All American Lodge Greatest in Elkdome
34212 Elks Rd
Slidell, LA 70460

Permit Number: LAG532887
Agency Interest Number: 157925

RE: Renewal of Coverage under LPDES General Permit (LAG530000) for Discharges of Treated Sanitary Wastewater and/or Other Accepted Wastewater Types Totaling Less than 5,000 Gallons per Day

Dear Permittee:

The Louisiana Department of Environmental Quality (LDEQ) has reissued the LPDES General Permit LAG530000 permit with an effective date of December 1, 2022. Pursuant to the Louisiana Environmental Quality Act (La R.S. 30:2001 et seq), authorization under the Permit, is hereby extended to

All American Lodge Greatest in Elkdome
34212 Elks Rd
Slidell, LA

to discharge treated sanitary wastewater (less than 5,000 GPD) from your facility into subsegment 040905. If circumstances at the permitted facility are expected to change in the future and the change will result in the addition or elimination of permitted outfalls, or a change in the composition of effluent from a permitted outfall, the permittee is required to notify the Water Permits Division of the proposed changes and to receive the appropriate permit coverage prior to adding a new outfall or changing the composition of effluent from a permitted outfall. This reissued permit will replace and cancel the prior version of the permit which was previously issued to your facility. Please note that your permit number will remain the same. **To ensure that all correspondence regarding this facility is properly filed into the LDEQ's Electronic Document Management System (EDMS), you must reference your Agency Interest Number AI 157925 and LPDES general permit authorization number LAG532887 on all future correspondence to LDEQ.**

The permittee shall follow the Effluent Limitations and Monitoring Requirements established in **Appendix A**, which is attached to this permit. Appendix A is facility specific and details which schedule(s) from Part I of the permit apply to the facility. Please note that any schedule in Part I of the permit that is **NOT** listed in Appendix A shall **NOT APPLY** to this particular facility.

Please review the Effluent Limitations and Monitoring Requirements in Appendix A. If there is an error, please contact the Water Permits Division for assistance.

Pursuant to LAC 33:IX.2701.L.4.a, monitoring results shall be reported to the Enforcement Division through a department-approved electronic document receiving system (NetDMR). Paper DMRs or an alternative substitute may only be utilized by the permittee if the LDEQ Enforcement Division grants a written authorization to the permittee. See the enclosed NetDMR information sheet.

Your facility will be assessed an Annual Maintenance and Surveillance Fee to be invoiced separately by the LDEQ. Annual fee amounts are subject to adjustment at a later date by promulgation of changes in the Louisiana Administrative Code (LAC). Pursuant to LAC 33:IX.1309.I, LAC 33:IX.6509.A.1 and LAC 33:I.1701, you must pay any outstanding fees to the LDEQ. Therefore, please verify your facility's fee status by contacting LDEQ's Office of Management and Finance, Financial Services Division at (225) 219-3863. Any outstanding fees must be remitted via a check to the LDEQ within thirty (30) days after the effective date of your permit. Failure to pay the full amount due in the manner and time prescribed could result in applicable enforcement actions as prescribed in the Environmental Quality Act, including, but not limited to revocation or suspension of the applicable permit, and/or a civil penalty against you.

A copy of the permit can be accessed and printed from LDEQ's Internet website at <http://www.deq.louisiana.gov> using the following path: WATER – Permits – LPDES Permit Information – LAG530000 or by entering the Document ID 13545668 in LDEQ's Electronic Document Management System (EDMS) search window found at <http://edms.deq.louisiana.gov/app/doc/quervdef.aspx>. In the event you are unable to access and/or print a copy of this permit for your records from one of the above listed sources, please contact the Water Permits Division at (225) 219-3590 to request a hard copy be sent by mail. In compliance with LAC 33:IX.2701.H, the permittee may be required to provide a copy of the permit at the request of the administrative authority. Please read the entire permit very carefully to ensure that you thoroughly understand the conditions of the permit.

For all sanitary treatment plants, the plans and specifications must be approved by the Department of Health, Office of Public Health, P.O. Box 629, Baton Rouge, Louisiana 70821-0629, (225) 342-8093.

Please be advised that according to LA R.S. 48:385, any direct discharge to a state highway ditch, cross ditch, or right-of-way shall require approval from the Louisiana Department of Transportation and Development, P.O. Box 94245, Baton Rouge, Louisiana 70804, (225) 379-1927, and from the Department of Health, Office of Public Health, P.O. Box 629, Baton Rouge, Louisiana 70821-0629, (225) 342-8093.

Should you have any questions concerning the general permit, please feel free to contact Laura Thompson at (225) 219-0803 or Rachel Davis at (225) 219-3515.

Sincerely,



Kimberly Corts, Manager
General and Municipal Permit Section

Attachments: Appendix A and NetDMR Information

cc: IO-W

To insure maximum retention and eliminate short circuiting of raw sewage particle, the aeration chamber shall be constructed with air diffusers placed longitudinally along one side of the chamber so as to, in conjunction with the flow control baffles, enhance the spiral rotation of the chamber content. To insure adequate circulation velocity the proportion of chamber width to depth, in the direction of rotation of the chamber content, shall not exceed 1.33 to 1. The velocity of rotation shall be sufficient to scour the bottom and prevent sludge filleting as well as to prevent the escape to the surface of minuscule air diffusion bubbles and so causing their entrapment to provide maximum oxygenation efficiency. An air distribution manifold shall be installed longitudinally on one side of the tank with diffuser drop assemblies connected there to. Each diffuser drop assembly shall be equipped with an air regulating and/or shutoff valve, a disconnecting union and a diffuser bar with air diffuser nozzles minimum air velocity shall be maintained to insure efficient velocity of self cleaning. The diffusers shall be parallel to, and near the base of the vessel side wall, and at an elevation which will provide the optimum diffusion and mixing of the vessel content. The oxygen transfer capacity detailed in the aeration chamber will be designed to meet treatment requirements of the design sewage load.

Clarifier Chamber

There shall be a clarifier chamber to work in conjunction with the aeration chamber of that system. The clarifier shall conform to the following specification: The clarifier chamber shall be of such as to provide a minimum of four hours retention, based upon the same design flow rate governing the aeration chamber, but including adjustment of such rate to compensate for run-off period, and shall have proper baffling to prevent short circuiting and to provide maximum uniform solids settling areas.

The bottom of the chamber wall shall be formed into an inverted pyramidal hopper or hoppers. The flat bottom area of each hopper shall not exceed one square foot. The slope of the hopper walls shall not be less than 1.7 vertical to 1.0 horizontal. Settled sludge shall be returned from the clarifier sludge hopper to the aeration chamber by the positive sludge return system, consisting of 1 air-lift pumps. The clarifier effluent shall pass over the edge of the baffled adjustable trough and then out of the chamber.

Outlet Connection

The plant discharge connection shall be one 4" (four inch) inch FNPT collar.

Air Supply Blower Motor Units

A total of 2 positive displacement blower motor unit(s) shall be supplied, capable of providing a minimum of 2,100 cubic feet of air per pound of BOD5 delivered, and/or a minimum of 3 CFM per lineal foot of aeration tank length to meet the air requirement of the total system. Each blower shall be capable of delivering 36 CFM when operating at 4 PSI. The blower shall be manufactured by Roots, Industrial Machinery, or an approved equal. The Model number of the blower is URAI24. The motor shall be 2 HP for operating on 230 volts ac single Phase, 60 cycles and 3600 RPM. It shall be of the totally enclosed, fan cooled type. Each blower shall be mounted on an adjustable base. The base structure shall be adequately reinforced to support the blower(s) and motor(s) unit. For easy adjustment of the "V" belt drive connection between the blower and motor, the motor will be furnished with an adjustable motor mounting base. The blower shall be fitted with a dry type air filter-silencer at the air intake. The blower discharge shall be fitted with a check valve when required, and a flexible rubber discharge coupling. Each blower and motor shall be enclosed with a weatherproof enclosure. The hood is designed for easy

access to service the unit. It shall be equipped with a lifting handle and locking device. All enclosure surfaces shall be properly prepared in a neat manner to obtain a smooth, clean and dry surface. To help reduce blower vibration and noise the blower motor enclosure shall be mounted on vibration dampers. For purpose of the blower performance and/or diffuser condition, a pressure relief valve and pressure gauge shall be mounted in the air manifold.

Air Blower Motor – Compressor Package Mounting (Optional)

The air blower – compressor package will be ground mounted next to the plant to minimize noise, improve plant maintenance, and improve personnel safety.

Electrical Control Center

An electrical control panel shall be installed within a weatherproof enclosure, and shall be provided for mounting as indicated on the plans. The enclosure shall be equal to NEMA type 3-R. The electrical controls shall consist of magnetic starters, program timers, and switches necessary to automatically and manually control all electrical devices and/or motors in the sewage treatment system. The blower motor shall be controlled by selector switches and magnetic starters in conjunction with the program timer. The program timers shall have the capability to operate the treatment system when required and as determined by the variations in the daily flow rate. All electrical equipment and circuitry shall be protected by properly sized circuit breakers or fuses. All duplex or standby equipment shall be designed so that it may be operated by devices within the control system. All wire and conduit required between the control panel and the electrical power service shall be furnished and installed by the purchaser. Wiring and conduit between the control panel and plant equipment shall be furnished by the manufacturer of the waste water treatment plant. The panel may be detached for shipping. The main power supply to be furnished by the customer shall be 230 volts ac, single phase, at 60 cycles.

Electrical Control – Breaker Panels Mounting (Optional)

All Electrical circuit breaker and control panels will be mounted on the ground next to the plant where practical.

Chlorinator

A chlorine chamber, when required, shall be furnished with a baffled chamber, constructed integrally with the clarifier designed to provide disinfection of the secondary effluent. The tank shall be sized for a capacity of 110 gallons. Baffles shall be provided to eliminate short circuiting and shall be designed to keep floating material from leaving the chamber. Sufficient flow baffles will be supplied to assure proper mixing of the chlorine solution with the plant effluent. The chlorination equipment shall consist of a Norweco Tablet Feeder. The Chlorinator shall have the capacity of disinfecting the effluent from the treatment system.

Field Assembly

In almost every case, shipment on your prefabricated treatment plant is done by special lowboy trailers. When your plant is shipped by truck, delivery will be made directly to the job site. The equipment necessary to unload a plant and set it on the foundation pad must be furnished by the customer. A crane of adequate size is usually the simplest method for unloading the plant which will weigh 13,000 Lbs.

Lifting lugs are supplied on the tank to ease handling on a 4 - point sling or cable. When the plant arrives at the job site, the customer's contractor should have available the necessary equipment to unload and set the tank on the foundation pad. After setting the plant in position, a check should be made to see that it is level, and in the correct position. Our package concrete treatment system shall be completely assembled units and are shipped as a unit where shipping weight limitations permit. If a portion of the equipment must be removed to meet shipping height limitations, this equipment will be packaged separately at the factory for field assembly. This equipment and tankage should be field assembled and installed by the customer's contractor in the field.

The field contractor shall perform and/or make the following arrangements:

1. Field unloading and placing of the plant on its foundation pad, anchoring in position where required.
2. Install, at the location shown on the plan, the ancillary equipment which has been disconnected at the factory for shipping purposes.
3. Connection of piping and wiring which may have been disconnected at the factory for shipment.
4. Tie-in of all piping and wiring connections to site utilities.
5. Install drain plugs and partially fill tank with water to check for leaks, and proper rotation of 3 - phase blower and lift pumps.

Sludge Re-circulation System

There shall be installed within the clarifier chamber(s) a positive sludge return system, consisting of one 2- inch diameter airline sludge return assembly(s) meeting the following specifications: The airlift system shall have the re-circulation capacity ranging from 0% to 150% of the design flow. The airline supplying air to the system shall be equipped with a valve to vary the return capacity of the system. The airlift system shall be firmly supported and shall be equipped with a clean out plug to allow cleaning and maintenance.

Scum Re-circulation System

There shall be installed within the clarifier chamber a positive scum and skimming re-circulation system consisting of 1 airlifting skimming device(s) meeting the following specifications: The skimming device shall be of the positive airlift type, located in a position to skim and return floating material to the aeration chamber. The air line supplying air to the skimming device shall be equipped with a valve which will enable adjustment of the return flow rate. There should be an adjustable skimmer head for exact positioning of the skimmer head at water level.

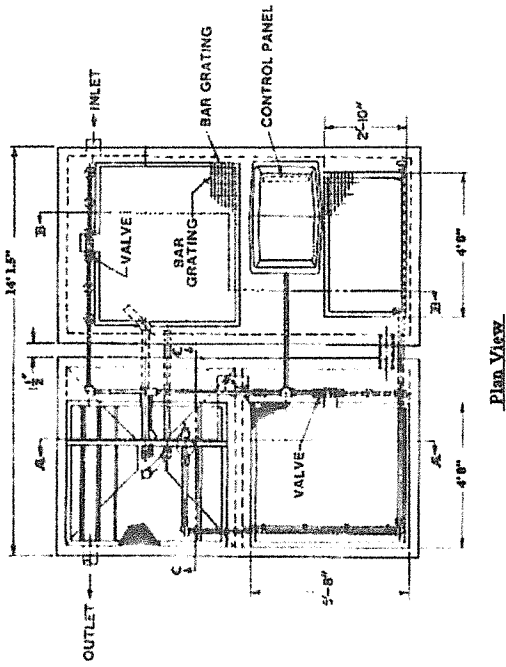

EJ BREAUX CONTRACTORS, LLC
 115 LEONIE ST.
 PIERRE PART, LA. 70339
 985-252-6183

PLANT SIZE	5,000 GPD
A	102"
B	100"
C	102"
D	10"
E	101"

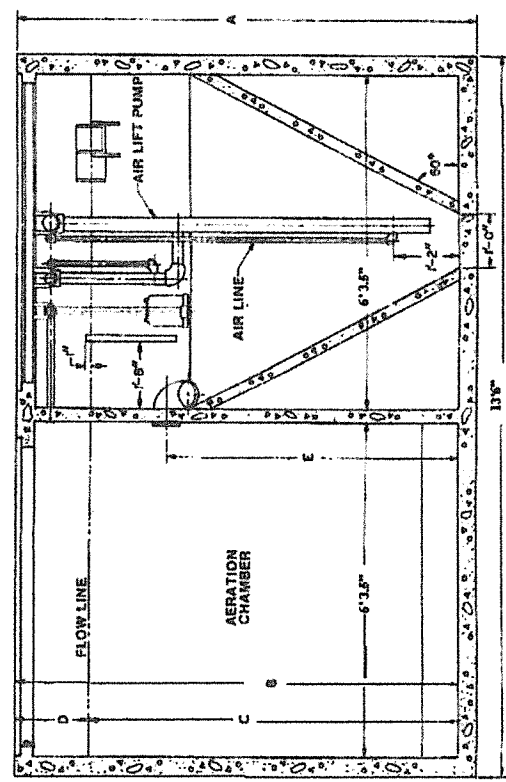
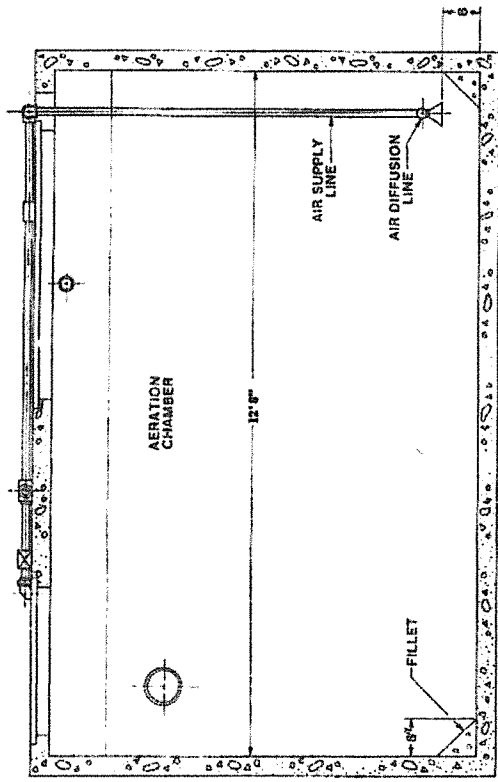
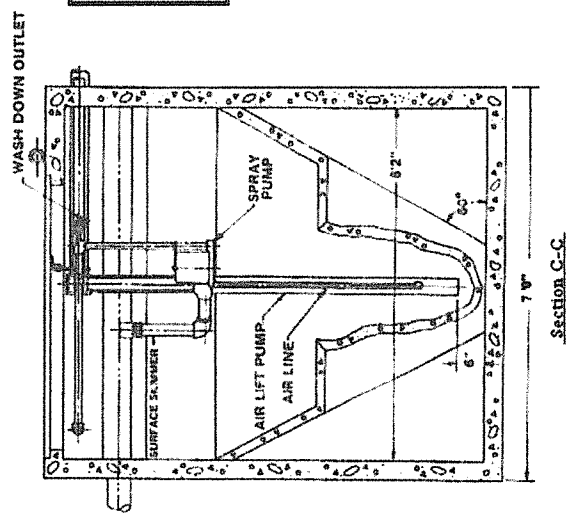

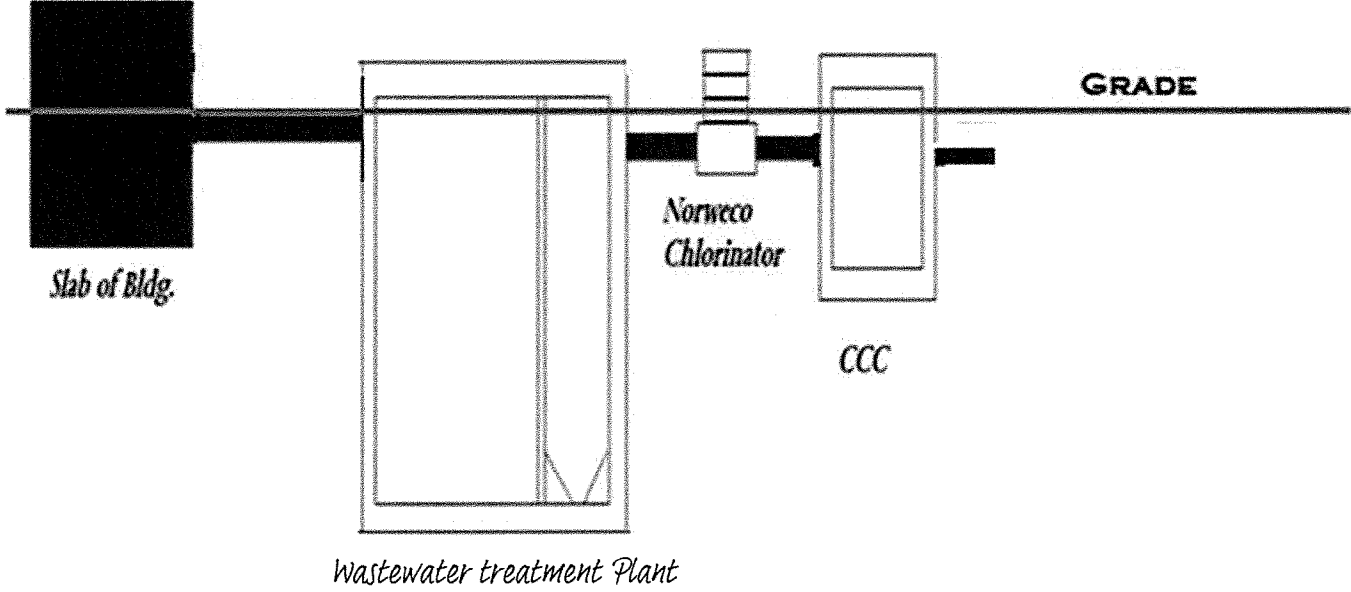

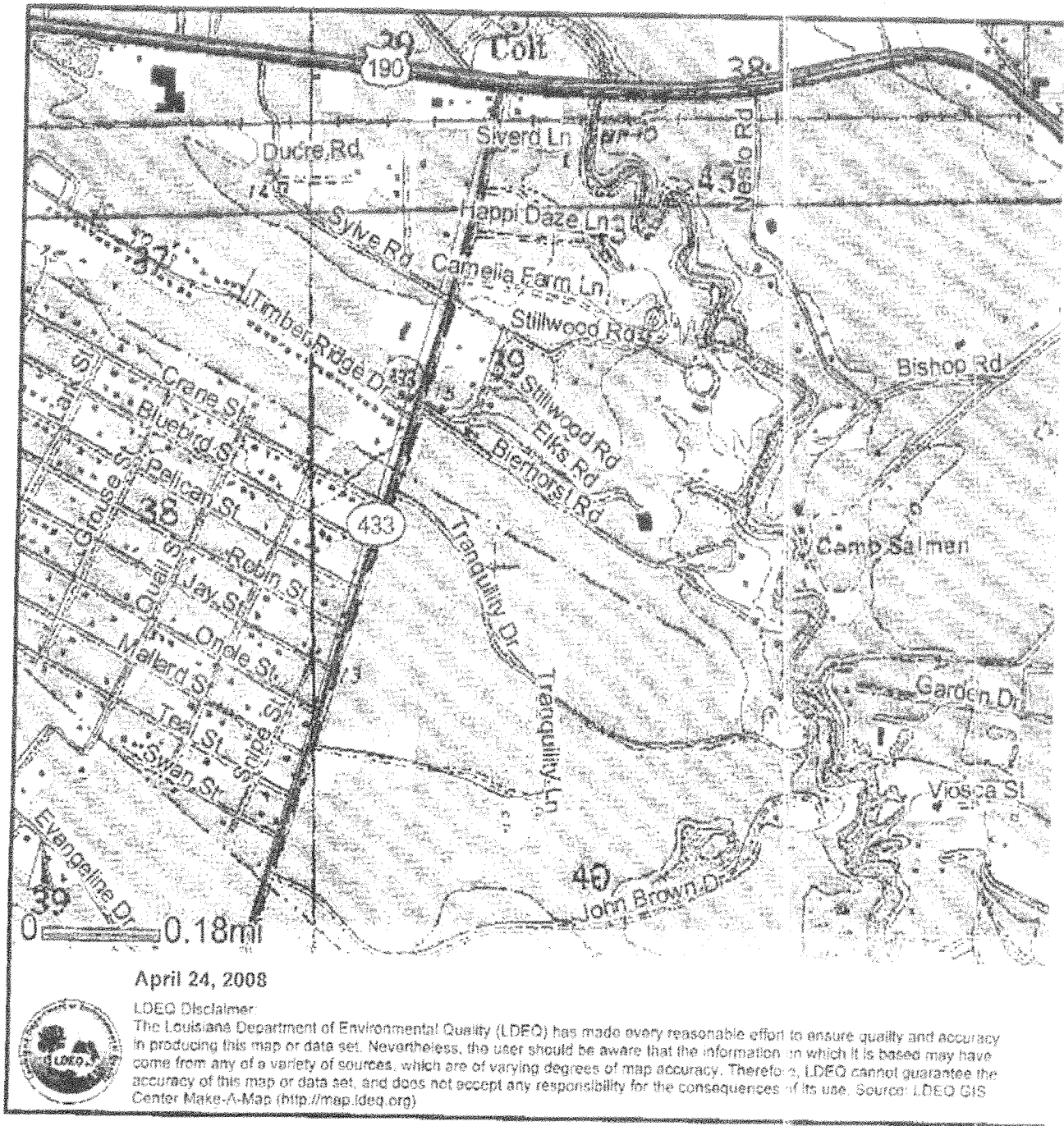

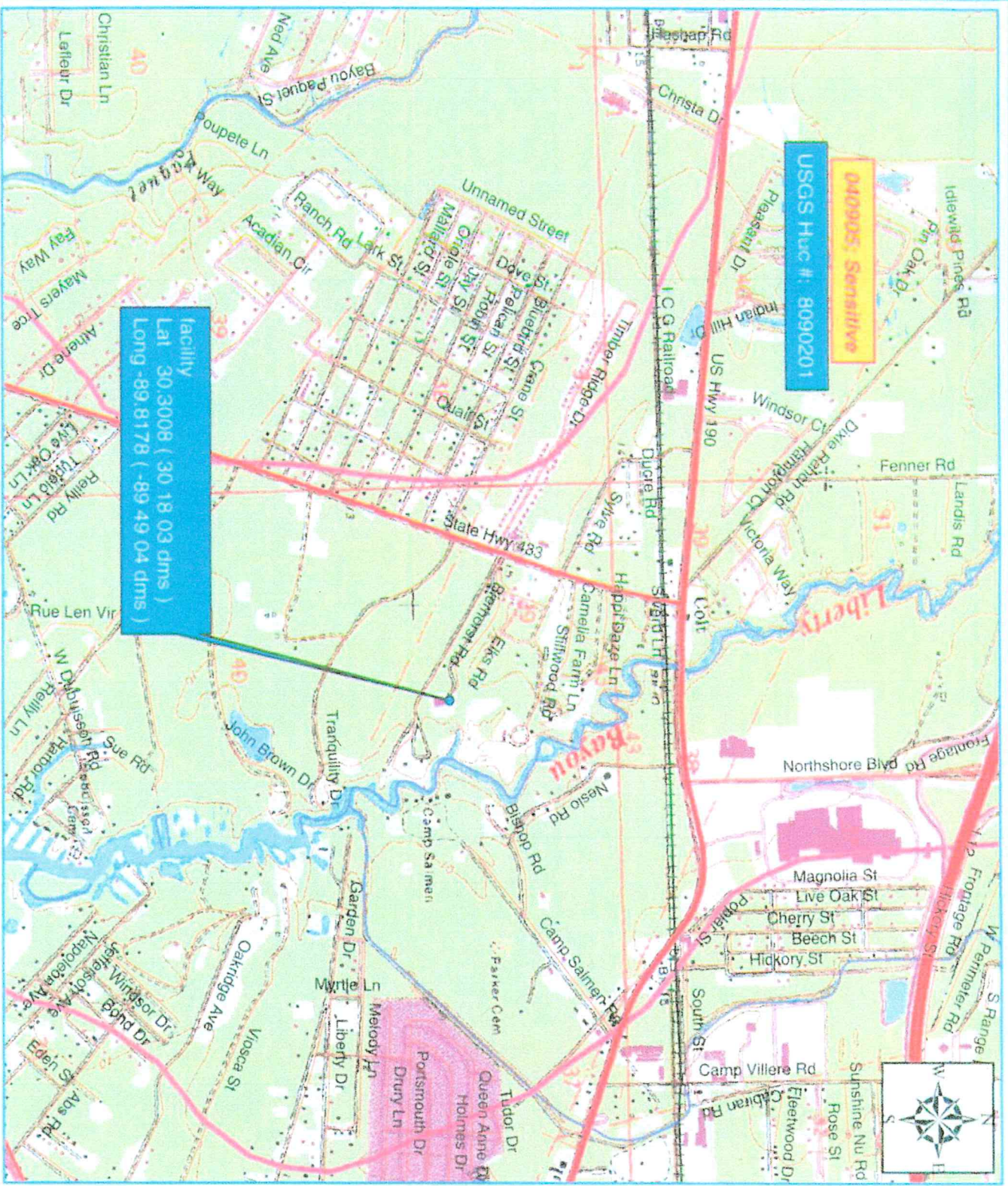

All American Lodge
 Greatest in Elkdom
 AH# 157925

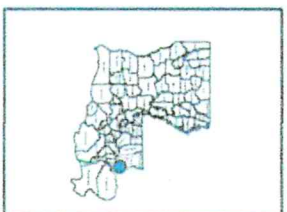

LDEQ Disclaimer:
 The Louisiana Department of Environmental Quality (LDEQ) has made every reasonable effort to ensure quality and accuracy in producing this map or data set. Nevertheless, the user should be aware that the information on which it is based may have come from any of a variety of sources, which are of varying degrees of accuracy. Therefore, LDEQ cannot guarantee the accuracy of this map or data set, and does not accept any responsibility for the consequences of its use.

Creation Date: June 5, 2008. MAP# 2008-02-154. Created By: Debbie Bassett
 Data Sources: See provided by All American Lodge. Graveled in Elkdome, 2002. USGS HUC# 2004. LDEQ Subseparments
 2000 Census. Tiger Line Roads. 1999 ESRH Parcels. 1999 ELOTD Parish Boundaries.
 1999 ESRH/EDD. Wetlands. 1988 USGS Census Community/Airport/Cemetery
 Wetlands from USGS 1:100000 D. Co. 1:24000 USGS (DHEC, 1981). AC 301X Chapter 25.
 1999 Lakes and Reservoirs River digital from USGS 1:24000 (DHEC, 1999).
 1998 LDEQ Water Quality Inventory
 This map is intended for LDEQ internal use only.

CERTIFICATION OF CONSTRUCTION

Date: _____

Project Name: _____

Permit Number: _____

I hereby certify that, to the best of my knowledge, construction for the above referenced project has been completed in accordance with the plans and specifications approved by your office in your letter dated _____. The facility is now ready for operation.

Sincerely,

Engineer of Record (Seal & Signature)

Contractor